

SUPER FLEXIBLE NOZZLES



Structure and Features

IKO Super Flexible Nozzle is a compact nozzle for use on a machine tool to supply and spray cutting oil exactly at the required positions.

The angle of the nozzle can be changed easily and freely. Therefore, oil supply can be concentrated upon the working area, and cooling and lubrication can be performed effectively. As a result, cutting resistance is reduced and superior finish is obtained, achieving high machining accuracy. Also, tool life is longer.

The Super Flexible Nozzle is used in many places such as at the spindle end of Machining Center and at the tool holder of N/C lathe.

The features of Super Flexible Nozzle are as follows.

- ① A spherical bushing is incorporated to adjust the tilting angle of nozzle easily.
- ② The Super Flexible Nozzle is compact in size, and the design on parts around the spindle and tool can be made simple.
- ③ The nozzle length is short, and winding of cutting chips around the nozzle will not occur.
- ④ By using a number of Super Flexible Nozzles, cutting oil can be supplied and cutting chips can be removed more effectively.
- ⑤ The press fitting type and screw fitting type are available. The press fitting type is economical.

Structures of Super Flexible Nozzles

SNA [Without nozzle]

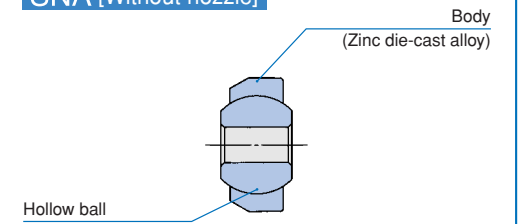

SNA [With nozzle]

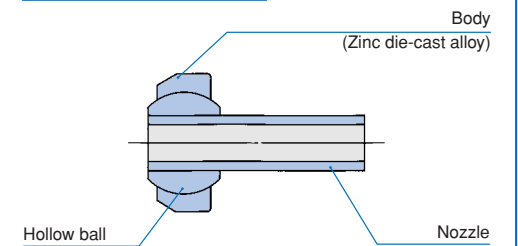

SNM

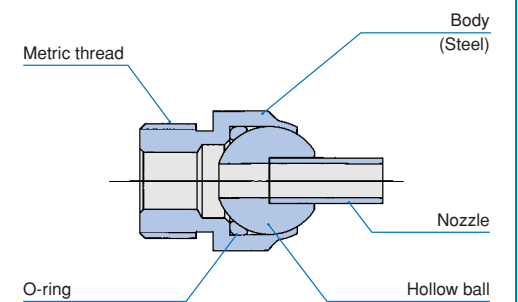

SNPT

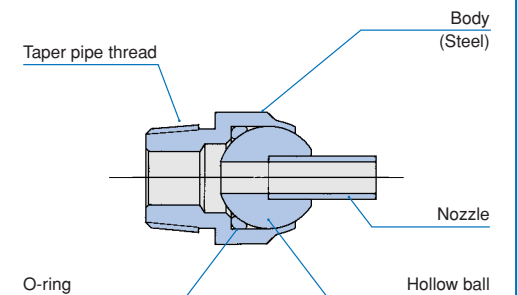

Types

Super Flexible Nozzles shown in Table 1 are available.

Table 1 Type of Super Flexible Nozzle

Type		Model code
Press fitting type	Without nozzle	SNA
	With nozzle	
Screw fitting type	With metric threads	SNM
	With taper pipe threads	SNPT

Identification Number

The identification number of Super Flexible Nozzle consists of a model code and a size. An example is shown as follows.

Example of identification number

Model code	Size
SNM	10-20

Type of nozzle: SNM
 Nozzle bore or thread size: (M10×1.25)
 Dimension from shoulder surface to nozzle top:※ (20mm)

※ In case of press fitting type without nozzle, this dimension is not indicated.

Precautions for Use

When the press fitting type Super Flexible Nozzle is used, a $\phi 15$ (H8) $^{+0.027}_0$ bore for fitting hole must be prepared and fitting is made from the 30° chamfered end of the outer body. In this case, the body portion should be pushed for press fitting.

When the screw fitting type Super Flexible Nozzle is used and prevention of oil leakage from the fitting part is required, it is recommended to wind sealing tape on the thread portion or use rubber packing for the shoulder face of the outer body.

The direction of lubrication can be adjusted by inserting a screwdriver, etc. in the bore of the nozzle.

Special Specifications

Super Flexible Nozzles with special length are also available. In this case, specify the necessary nozzle length in units of 1 mm, but do not exceed the maximum length shown in the dimension table as "L".

Super Flexible Nozzles with curved nozzle end or with special bore diameter are also available. In this case, please contact **IKO** by preparing a drawing or sketch with necessary specifications.

SUPER FLEXIBLE NOZZLE

Press Fitting Type **Without Nozzle**

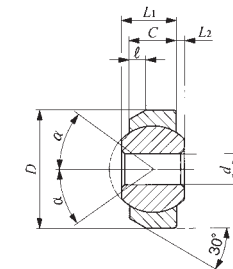

SNA

Identification number	Boundary dimensions mm						Ball dia. mm (inch)	Allowable tilting angle α degree
	d	D	L ₁	L ₂	C	ℓ		
SNA 4	4	15	7	1	6	2	11.112 ($\sqrt[16]{16}$)	36
SNA 6	6							24

Press Fitting Type **With Nozzle**

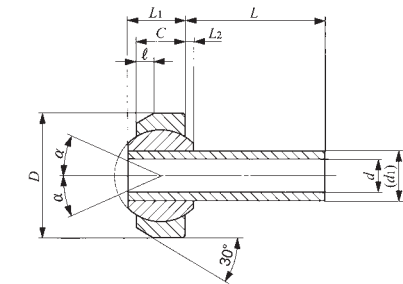
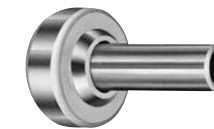

SNA

Identification number	Boundary dimensions mm									Ball dia. mm (inch)	Allowable tilting angle α degree	
	d	D	L			L ₁	L ₂	C	ℓ			d ₁
SNA 3-L	3	15	6	15	32	7	1	6	2	6	11.112 ($\sqrt[16]{16}$)	24
SNA 4-L	4		6	16	40							

SUPER FLEXIBLE NOZZLE

Screw Fitting Type

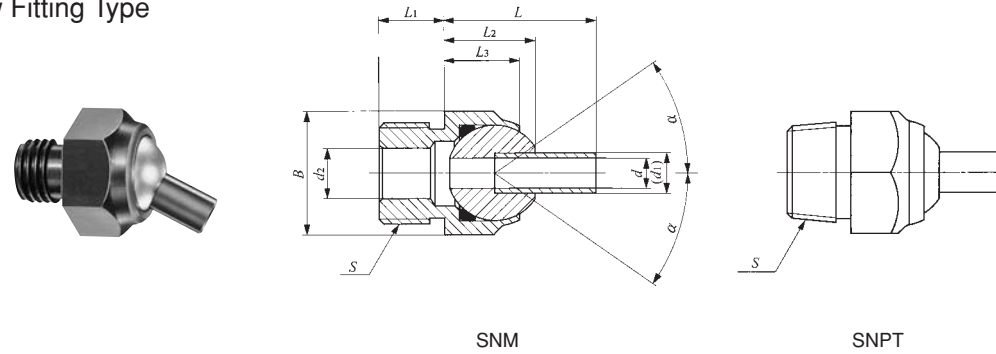

Identification number	Boundary dimensions mm										Ball dia. mm (inch)	Allowable tilting angle α degree	
	d	Thread S	L	L_1	L_2	L_3	d_1	d_2	Width across flats B	Width across corners (Ref.)			
SNM 10-L	4	M10 × 1.25	20	40	60	9	13	10.5	6	6	17	19.6	35
SNPT 1/4-L		PT 1/4											
SNM 20-L	6	M20 × 1.5	30	50	70	13	18	15	8	10	24	27.7	
SNPT 3/8-L		PT 3/8											
SNM 24-L	8	M24 × 2.0	40	60	80	18	23	19	10	12	32	37	
SNPT 1/2-L		PT 1/2											

PARTS FOR NEEDLE ROLLER BEARINGS

- Seals for Needle Roller Bearings
- Cir-clips for Needle Roller Bearings
- Needle Rollers

