



BEARINGS

Deep groove ball bearings



Deep groove ball bearings

Deep groove ball bearings are manufactured in a varied range, both of standard design and various constructive versions.

Deep groove ball bearings can take double direction radial

and axial loads and also allow good operation at high speeds.

For these reasons, they can be widely used. Therefore, single row deep groove ball bearings are manufactured in many constructive versions as shown below.

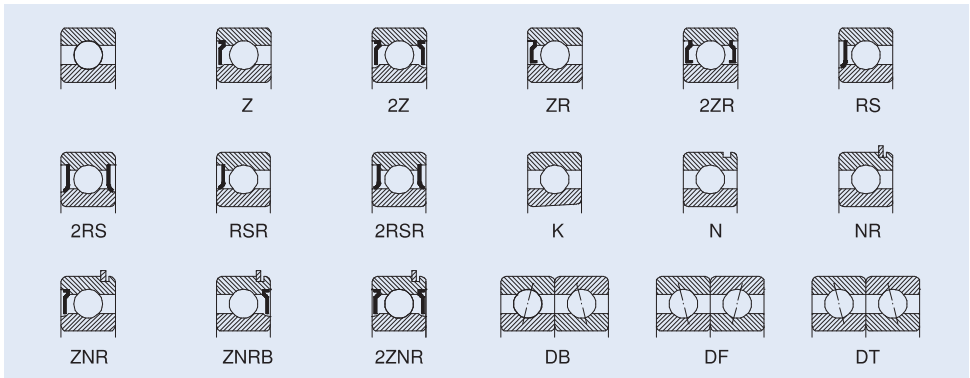

Besides deep groove ball bearings of basic design, bearings with UG design, with grooves on the outer ring and WL design, with grooves on both rings are also used for the purpose of mounting seals or shields on bearings, 2ZR, 2RSR or 2RS type, as shown in the bellow figure.

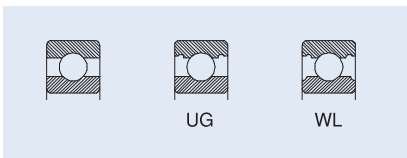

Suffixes

- A** - bearing with extended outer ring
- B** - bearing with extended inner ring
- C2** - radial clearance smaller than normal
- C3** - radial clearance larger than normal

- FA** - machined cage of steel or cast iron guided in the outer ring
- F2** - constructive modifications
- K** - bearing with tapered bore
- M** - machined cage of brass guided on the rolling elements
- MA** - machined cage of brass guided in the outer ring
- MB** - machined cage of brass guided on the inner ring
- N** - circular groove for snap ring on the outer ring
- NR** - circular groove on the outer ring and snap ring
- P0** - normal tolerance class (it is not marked)
- P6** - tolerance class more accurate than normal
- P63** - tolerance class P6 and radial clearance C3
- P5** - tolerance class more accurate than P6
- P4** - tolerance class more accurate than P5
- R** - rib on the outer ring
- RS** - bearing with seal on one side, with friction on the inner ring recess
- RSA** - bearing with special seal
- 2RS** - bearing with 2 seals, friction on the inner ring recess

- RSR** - bearing with seal on one side, friction on the rib of the inner ring
- 2RSR** - bearing with 2 seals, friction on the rib of the inner ring
- S0** - bearing which can operate up to a temperature of +150°C
- S1** - bearing which can operate up to a temperature of +200°C
- SP** - snap ring, diameter series 0, 2, 3, 4
- SR** - snap ring, dimension series 18 and 19
- T30** - bearing which can operate up to a temperature of +300°C, radial clearance 0,20...0,25 mm; phosphate-treated surfaces
- TN** - polyamide cage
- V** - bearing without cage
- Z** - bearing with shield and recess on the inner ring
- ZZ** - bearing with 2 shields and recess on the inner ring
- ZNRB** - bearing with shield and snap ring on the same side
- ZR** - bearing with shield, without recess on the inner ring
- ZZR** - bearing with 2 shields, without recess on the inner ring

Sealed and shielded deep groove ball bearings

MTK manufactures two versions of sealed and shielded bearings, namely:

- bearings RS and Z type, with recess on the inner ring for sealing or shielding.

- bearings RSR and ZR type, when shielding and sealing respectively are done directly on the outside surface of the inner ring.

In case of bearings with non-rubbing shields, there is a small interstice between the shield and the rib of the inner ring; in case of bearings with seals, the gasoline and oil resistant elastic rubber lip rubs on the groove on the inner ring side or directly on the outside surface.

Bearings sealed and shielded on both sides manufactured in series are delivered filled with lithium base grease and are used at temperatures between -30°C and +110°C, in accordance with the specifications in chapter 5. Bearings can also be greased with special greases, relubrication not being necessary. Washing or heating are not allowed before bearing mounting in the assembly.

Bearings with shields have been designed first of all for cases when the inner ring rotates.

When the outer ring rotates, the lubricant can flow out of the bearing at a certain speed. In such cases, we recommend you to consult our experts.

Deep groove ball bearings with snap ring groove

Deep groove ball bearings, with snap ring groove on the outer ring can be located in the housing with snap rings.

Because of their simple and space saving mounting, these bearings simplify the assembly design. The groove for the snap ring and the snap rings are in accordance with ISO 464 and tables 7 and 8 respectively.

Paired deep groove ball bearings

If the basic load of a single bearing is inadequate or the shaft has to be axially located in both directions with a certain clearance, paired deep groove ball bearings are recommended to be used.

These bearings can be delivered matched in pairs in three versions, as follows: DT (tandem arrangement), DB (back-to-back arrangement) or DF (face-to-face arrangement). They can be delivered with axial clearance or preloaded. The values of clearance or preload are given in table 2.

The producer marks "V" on the bearing outside surface as shown in the next figure, so that paired bearings to be correctly mounted.

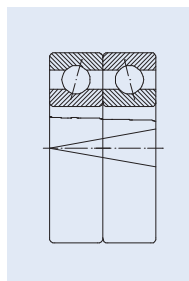

The speed limit of these bearings can be calculated multiplying the speed of the basic bearing by 0,8.

Paired bearings are packed and delivered in the same box.

Stainless steel deep groove ball bearings

Deep groove ball bearings can be made and constructive version of stainless steel.

Dimensions

The overall dimensions of deep groove ball bearings are in accordance with the stipulations of ISO 15.

Misalignments

Deep groove ball bearings have limited abilities to compensate for bearing errors of alignment. The permissible misalignment between the outer ring and the inner ring, which will not produce inadmissible high additional loads in the bearing, depends on the bearing size, operational radial clearance, inner bearing design and also on the magnitude of loads and moments acting upon the bearing.

Because of the complex relationship of these influence factors, definite and universally valid values of permissible misalignment cannot be determined.

Considering the above mentioned factors, under normal operation conditions the permissible misalignments

are between 2 and 10 minutes of arc, depending on the bearing series and load.

It should be considered that misalignments of bearing rings in operation produce a considerably higher noise .

Tolerances

Deep groove ball bearings are generally manufactured to the normal tolerance class P0.

At request, they can also be manufactured to the tolerance classes P6, P5 or P4.

The values of tolerances are given in chapter 3 on page 24.

Radial and axial clearance

Deep groove ball bearings are generally manufactured with normal radial clearance. At request, they can also be manufactured with radial clearance different from the normal one, according to ISO 5753. The values of radial clearance are given in table 1.

Paired bearings can be manufactured with axial clearance (suffix A) or preloaded (suffix L). Values for axial clearance and preload are given in table 2.

If a certain axial clearance is prescribed, this has to be measured and marked on the bearing by "A", followed by clearance actual value.

Radial clearance of deep groove ball bearings

Table 1

Bore diameter		Clearance group symbol for bearings with cylindrical bore									
		C2		Normal		C3		C4		C5	
d		Clearance group symbol for bearings with tapered bore									
--		C2		Normal		C3		C4		C5	
over	up to	min.	max.	min.	max.	min.	max.	min.	max.	min.	max.
mm		µm									
2,5	10	0	7	2	13	8	23	14	29	20	37
10	18	0	9	3	18	11	25	18	33	25	45
18	24	0	10	5	20	13	28	20	36	28	48
24	30	1	11	5	20	13	28	23	41	30	53
30	40	1	11	6	20	15	33	28	46	40	64
40	50	1	11	6	23	18	36	30	51	45	73
50	65	1	15	8	28	23	43	38	61	55	90
65	80	1	15	10	30	25	51	46	71	65	105
80	100	1	18	12	36	30	58	53	84	75	120
100	120	2	20	15	41	36	66	61	97	90	140
120	140	2	23	18	48	41	81	71	114	105	160
140	160	2	23	18	53	46	91	81	130	120	180
160	180	2	25	20	61	53	102	91	147	135	200
180	200	2	30	25	71	63	117	107	163	150	230
200	225	2	35	25	85	75	140	125	195	175	265
225	250	2	40	30	95	85	160	145	225	205	300
250	280	2	45	35	105	90	170	155	245	225	340
280	315	2	55	40	115	100	190	175	270	245	370
315	355	3	60	45	125	110	210	195	300	275	410
355	400	3	70	55	145	130	240	225	340	315	460

Axial clearance and mounting preload of paired bearings series 60, 62, 63

Table 2

Bore diameter d		Axial clearance (suffix A)		Preload (suffix L)		
				Bearing series		
over	up to	min.	max.	60	62	63
mm		µm		N		
—	10	15	35	30	30	—
10	18	20	40	50	50	100
18	30	25	45	100	100	100
30	50	35	55	100	100	200
50	80	40	70	200	200	350
80	120	50	80	300	400	600
120	180	60	100	500	700	900
180	250	70	110	800	1000	1200

Cages

Deep groove ball bearings are generally fitted with cages of pressed steel sheet.

Cages of glass fibre reinforced polyamide 6.6 are also suitable if the operating temperature doesn't exceed + 120°C. They have reduced weight, low coefficient of friction and are noiseless in operation. Large-sized bearings are fitted with machined brass cages.

Cage design and some technical data are given in table 3.

Bearing minimum radial load

A minimum load must be applied on a deep groove ball bearing so that they can operate correctly, especially in case of operating under heavy loads.

Cage design and technical data

Table 3

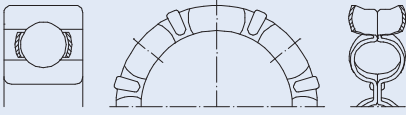
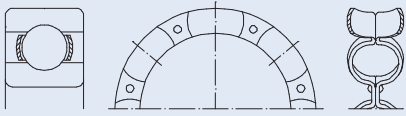
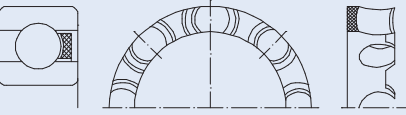
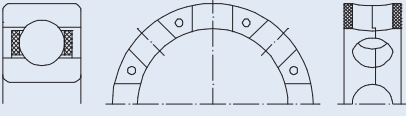
Cage	Design bearing cage	Application	Max. value	
			oil	Dm n grease
Pressed sheet cage with fins		<ul style="list-style-type: none"> - General application - Bearings with $d < 10$ mm - Low frictional moment - Low inertia - Moderate speeds. 	550×10^3	450×10^3
Pressed cage of riveted sheet		<ul style="list-style-type: none"> - General application - Bearings with $d > 10$ mm - Low frictional moment - Low inertia - Moderate speeds. 	1000×10^3	550×10^3
Polyamide cage		<ul style="list-style-type: none"> - General application - Low frictional moment - High speeds 	$1\,400 \times 10^3$	$1\,100 \times 10^3$
Brass machined cage		<ul style="list-style-type: none"> - General application - Bearings: 61836-618/1400, 61936-619/950, 16036-16072, 6030-60/630, 6230-6248, 6320-6330. 	$1\,000 \times 10^3$	800×10^3

The forces of inertia which occur in bearing as well as the friction in lubricant influence negatively the operating conditions and can cause detrimental sliding movements between balls and raceways.

Minimum radial load depends on the bearing size, speed and lubricant viscosity at operating temperature. It can be roughly calculated from the equation:

$$F_{r \min} = 0,01C_r, \quad (C_r = \text{basic dynamic radial load}).$$

Equivalent dynamic radial load

Deep groove ball bearings can take also radial and axial combined loads.

For deep groove ball bearings, single or paired in tandem arrangement DT, equivalent dynamic radial load can be calculated using the equation:

$$P_r = F_r, \text{ kN}, \quad \text{when } F_a/F_r \leq e$$

$$P_r = X F_r + Y F_a, \text{ kN}, \quad \text{when } F_a/F_r > e$$

The greater the axial load, the greater the contact angle of these bearings.

Factors e , X and Y depend on the ratio $f_0 F_a / C_{0r}$. Factor f_0 can be determined using the diagram in the bellow figure, as a function of dimension series and mean diameter $(d + D)/2$. F_a

is the axial load and C_{0r} is the static basic load of the bearing.

The values of factors e , X , Y which depend on the bearing clearance can be determined from table 4, corresponding to the values of the ratio $f_0 F_a / C_{0r}$. The values in table 4 apply to bearings mounted with normal fit, i.e. shafts manufactured to tolerance class j5 or k5 and housing in J6, respectively.

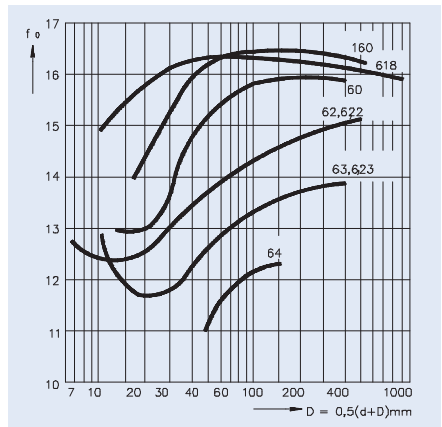

Calculation factors e, X and Y for deep groove ball bearings, single mounted or matched in tandem.
Table 4

$f_0 F_a / C_{0r}$	Normal radial clearance			Radial clearance C3			Radial clearance C4		
	e	X	Y	e	X	Y	e	X	Y
0,2	0,19	0,56	2,25	0,32	0,46	1,77	0,38	0,44	1,44
0,4	0,22	0,56	1,95	0,34	0,46	1,63	0,42	0,44	1,36
0,8	0,26	0,56	1,68	0,38	0,46	1,44	0,45	0,44	1,25
1,6	0,31	0,56	1,40	0,43	0,46	1,27	0,48	0,44	1,16
3	0,37	0,56	1,20	0,48	0,46	1,14	0,52	0,44	1,08
6	0,44	0,56	1,02	0,54	0,46	1	0,56	0,44	1

For bearings matched in DB or DT arrangement, equivalent dynamic radial load can be calculated using the equation:

$$P_r = F_r + Y_1 F_a, \text{ kN, when } F_a / F_r \leq e,$$

$$P_r = 0,75 F_r + Y_2 F_a, \text{ kN, when } F_a / F_r > e.$$

The values of factors e, Y_1 and Y_2 , as functions of ratio F_a / C_{0r} are given in table 5.

The shoulder should have the proper height corresponding to maximum bearing mounting chamfer.

The values of the connection radius (r_u) and support shoulder height (h_u) as functions of mounting chamfers are given in table 6.

Equivalent static radial load

For deep groove ball bearings, single or matched in tandem (DT), equivalent static radial load can be calculated using the equations:

$$P_0 = F_r, \text{ kN, when } F_a / F_r \leq 0,8$$

$$P_0 = 0,6 F_r + 0,5 F_a, \text{ kN, when } F_a / F_r > 0,8$$

For bearings matched in DB or DF arrangement, it can be calculated from:

$$P_0 = F_r + 1,7 F_a, \text{ kN}$$

Calculation factors e, Y_1 , Y_2 for DB and DF arrangements

Table 5

F_a / C_{0r}	e	Y_1	Y_2
0,03	0,32	2	2,8
0,10	0,4	1,55	2,2
0,25	0,47	3	1,65

Abutment dimensions

Table 6

r_s min.	r_u max.	h_u min.	Bearing series		
			618,619, 160	161,60, 62,63	64
mm					
0,15	0,15	0,4	0,7	–	–
0,2	0,20	0,7	0,9	–	–
0,3	0,30	1	1,2	–	–
0,6	0,60	1,6	2,1	–	–
1	1	2,3	2,8	–	–
1,1	1	3	3,5	–	4,5
1,5	1,5	3,5	4,5	–	5,5
2	2	4,4	5,5	–	6,5
2,1	2,1	5,1	6	–	7
3	2,5	6,2	7	–	8
4	3	7,3	8,5	–	10
5	4	9	10	–	12
6	5	11,5	13	–	15
7,5	6	14	–	–	–

Axial load

If deep groove ball bearings are purely axial loaded, the axial load should not exceed $0,5 C_{0r}$. In case of small-sized bearings and bearings of light series (diameter series 8, 9, 0 and 1), the axial load should not exceed $0,25 C_{0r}$.

Heavy axial loads cause a significant decrease of bearing rating life. In such cases, we recommend you to consult our experts.

Abutment dimensions

For a proper location of bearing rings on the shaft shoulder and housing shoulder, respectively, maximum shaft (housing) connection radius $r_{u \text{ max}}$ should be less than minimum bearing mounting chamfer $r_{s \text{ min}}$.

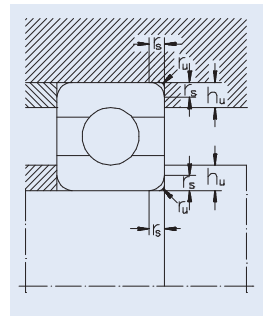

Snap ring groove and snap ring dimensions and tolerances

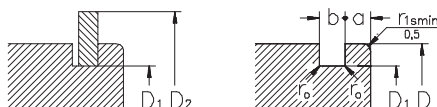

Snap ring groove

Outer diameter D	D ₁		a				b		r ₀	
	nom.	toler.	18		Dimensions series 19		nom.	toler.	nom.	toler.
mm										
22	20,8	-0,3	-	-	1,05	-0,15	0,8	+0,25	0,2	-0,1
24	22,8	-0,3	-	-	1,05	-0,15	0,8	+0,25	0,2	-0,1
28	26,7	-0,3	-	-	1,3	-0,15	0,95	+0,25	0,25	-0,12
30	28,7	-0,3	-	-	1,3	-0,15	0,95	+0,25	0,25	-0,12
32	30,7	-0,3	1,3	-0,15	-	-	0,95	+0,25	0,25	-0,12
34	32,7	-0,3	1,3	-0,15	-	-	0,95	+0,25	0,25	-0,12
37	35,7	-0,3	1,3	-0,15	1,7	-0,15	0,95	+0,25	0,25	-0,12
39	37,7	-0,3	-	-	1,7	-0,15	0,95	+0,25	0,25	-0,12
40	38,7	-0,3	1,3	-0,15	-	-	0,95	+0,25	0,25	-0,12
42	40,7	-0,3	1,3	-0,15	1,7	-0,15	0,95	+0,25	0,25	-0,12
44	42,7	-0,3	1,3	-0,15	-	-	0,95	+0,25	0,25	-0,12
45	43,7	-0,3	-	-	1,7	-0,15	0,95	+0,25	0,25	-0,12
47	45,7	-0,3	1,3	-0,15	1,7	-0,15	0,95	+0,25	0,25	-0,12
52	50,7	-0,3	1,3	-0,15	1,7	-0,15	0,95	+0,25	0,25	-0,12
55	53,7	-0,3	-	-	1,7	-0,15	0,95	+0,25	0,25	-0,12
58	56,7	-0,3	1,3	-0,15	-	-	0,95	+0,25	0,25	-0,12
62	60,7	-0,4	-	-	1,7	-0,15	0,95	+0,25	0,25	-0,12
65	63,7	-0,4	1,3	-0,15	-	-	0,95	+0,25	0,25	-0,12
68	66,7	-0,4	-	-	1,7	-0,15	0,95	+0,25	0,25	-0,12
72	70,7	-0,4	1,7	-0,15	1,7	-0,15	0,95	+0,25	0,25	-0,12
78	76,2	-0,4	1,7	-0,15	-	-	1,3	+0,3	0,4	-0,2
80	77,9	-0,4	-	-	2,1	-0,2	1,3	+0,3	0,4	-0,2
85	82,9	-0,4	1,7	-0,15	2,1	-0,2	1,3	+0,3	0,4	-0,2
90	87,9	-0,4	1,7	-0,15	2,1	-0,2	1,3	+0,3	0,4	-0,2
95	92,9	-0,4	1,7	-0,15	-	-	1,3	+0,3	0,4	-0,2
100	97,9	-0,4	1,7	-0,15	2,5	-0,2	1,3	+0,3	0,4	-0,2
105	102,6	-0,5	-	-	2,5	-0,2	1,3	+0,3	0,4	-0,2
110	107,6	-0,5	2,1	-0,2	2,5	-0,2	1,3	+0,3	0,4	-0,2
115	112,6	-0,5	2,1	-0,2	-	-	1,3	+0,3	0,4	-0,2
120	117,6	-0,5	2,1	-0,2	3,3	-0,2	1,3	+0,3	0,4	-0,2
125	122,6	-0,5	2,1	-0,2	3,3	-0,2	1,3	+0,3	0,4	-0,2
130	127,6	-0,5	2,1	-0,2	3,3	-0,2	1,3	+0,3	0,4	-0,2
140	137,6	-0,5	2,5	-0,2	3,3	-0,2	1,9	+0,3	0,6	-0,2
145	142,6	-0,5	-	-	3,3	-0,2	1,9	+0,3	0,6	-0,3
150	147,6	-0,5	2,5	-0,2	3,3	-0,2	1,9	+0,3	0,6	-0,3
165	161,8	-0,5	3,3	-0,2	3,7	-0,2	1,9	+0,3	0,6	-0,3
175	171,8	-0,5	3,3	-0,2	-	-	1,9	+0,3	0,6	-0,3
180	176,8	-0,5	-	-	3,7	-0,2	1,9	+0,3	0,6	-0,3
190	186,8	-0,5	3,3	-0,2	3,7	-0,2	1,9	+0,3	0,6	-0,3
200	196,8	-0,5	3,3	-0,2	-	-	1,9	+0,3	0,6	-0,3

The outer ring chamfer on the side of snap ring groove should allow a housing connection radius of:
 0,3 mm for dimension series 18, up to D = 78 mm included and for dimension series 19, up to D = 47 mm included;
 0,5 mm for dimension series 18, for D > 78 mm and for dimension series 19, for D > 47 mm

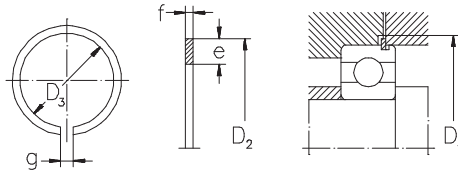

Snap ring

Table 7

Outer diameter	D ₂ ¹⁾	D ₃ ²⁾		D ₄	e	f	g	r	Weight	Snap ring designation	
	max.	nom.	toler.	min.	nom.	nom.	nom.	min.			
D										g	-
mm										g	-
22	24,8	20,5	-0,3	25	2	0,7	2	0,2	0,812	SR22	
24	26,8	22,5	-0,3	28	2	0,7	2	0,2	0,886	SR24	
28	30,8	26,4	-0,3	32	2,05	0,85	3	0,2	1,269	SR28	
30	32,8	28,3	-0,3	34	2,05	0,85	3	0,2	1,39	SR30	
32	34,8	30,3	-0,3	36	2,05	0,85	3	0,2	1,483	SR32	
34	36,8	32,3	-0,3	38	2,05	0,85	3	0,2	1,577	SR34	
37	39,8	35,3	-0,3	41	2,05	0,85	3	0,2	1,718	SR37	
39	41,8	37,3	-0,3	43	2,05	0,85	3	0,2	1,811	SR39	
40	42,8	38,3	-0,3	44	2,05	0,85	3	0,2	1,858	SR40	
42	44,8	40,3	-0,4	46	2,05	0,85	3	0,2	1,952	SR42	
44	46,8	42,3	-0,4	48	2,05	0,85	4	0,2	2,032	SR44	
45	47,8	43,3	-0,4	49	2,05	0,85	4	0,2	2,079	SR45	
47	49,8	45,3	-0,4	51	2,05	0,85	4	0,2	2,173	SR47	
52	54,8	50,3	-0,4	56	2,05	0,85	4	0,2	2,407	SR52	
55	57,8	53,3	-0,4	59	2,05	0,85	4	0,2	2,547	SR55	
58	60,8	56,3	-0,6	62	2,05	0,85	4	0,2	2,688	SR58	
62	64,8	60,2	-0,6	66	2,05	0,85	4	0,2	2,938	SR62	
65	67,8	63,2	-0,6	69	2,05	0,85	4	0,2	3,081	SR65	
68	70,8	66,2	-0,6	72	2,05	0,85	5	0,2	3,212	SR68	
72	74,8	70,2	-0,6	76	2,05	0,85	5	0,2	3,403	SR72	
78	82,7	75,7	-0,6	84	3,25	1,12	5	0,4	7,462	SR78	
80	84,4	77,4	-0,6	86	3,25	1,12	5	0,4	7,625	SR80	
85	89,4	82,4	-0,6	91	3,25	1,12	5	0,4	8,105	SR85	
90	94,4	87,4	-0,6	96	3,25	1,12	5	0,4	8,585	SR90	
95	99,4	92,4	-0,6	101	3,25	1,12	5	0,4	9,065	SR95	
100	104,4	97,4	-0,6	106	3,25	1,12	5	0,4	9,545	SR100	
105	110,7	101,9	-0,8	112	4,04	1,12	5	0,4	12,653	SR105	
110	115,7	106,9	-0,8	117	4,04	1,12	5	0,4	13,257	SR110	
115	120,7	111,9	-0,8	122	4,04	1,12	5	0,4	13,861	SR115	
120	125,7	116,9	-0,8	127	4,04	1,12	7	0,4	14,393	SR120	
125	130,7	121,8	-0,8	132	4,04	1,12	7	0,4	15,164	SR125	
130	135,7	126,8	-0,8	137	4,04	1,12	7	0,4	15,774	SR130	
140	145,7	136,8	-1	147	4,04	1,7	7	0,4	25,796	SR140	
145	150,7	141,8	-1	152	4,04	1,7	7	0,6	26,722	SR145	
150	155,7	146,8	-1,2	157	4,04	1,7	7	0,6	27,648	SR150	
165	171,5	161	-1,2	173	4,85	1,7	7	0,6	35,89	SR165	
175	181,5	171	-1,2	183	4,85	1,7	10	0,6	37,883	SR175	
180	186,5	176	-1,2	187	4,85	1,7	10	0,6	38,976	SR180	
190	196,5	186	-1,4	198	4,85	1,7	10	0,6	41,162	SR190	
200	206,5	196	-1,4	208	4,85	1,7	10	0,6	43,348	SR200	

1) D₂ dimension refers to the mounted snap ring
 2) D₃ represents dimension before mounting

Snap ring groove and snap ring dimensions and tolerances

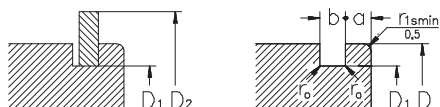

Snap ring groove

Outer diameter D	D ₁		a				b		r ₀	
	nom.	toler.	60	Dimensions series 62, 63, 64		nom.	toler.	nom.	toler.	
mm										
30	28,17	-0,25				-0,3				
32	30,15	-0,25	2	-0,15	1,35	+0,3	0,4	-0,2		
35	33,17	-0,25	2	-0,15	1,35	+0,3	0,4	-0,2		
40	38,10	-0,25				-0,2				
42	39,75	-0,25	2	-0,15	1,35	+0,3	0,4	-0,2		
47	44,60	-0,25	2	-0,15	0,35	+0,3	0,4	-0,2		
52	49,73	-0,25	2	-0,15	1,35	+0,3	0,4	-0,2		
55	52,60	-0,25	2			-0,2				
62	59,61	-0,5	2,08	-0,2	3,28	-0,2	1,90	+0,3	0,6	-0,3
68	64,82	-0,5	2,49	-0,2	3,28	-0,2	1,90	+0,3	0,6	-0,3
72	68,81	-0,5			3,28	-0,2	1,90	+0,3	0,6	-0,3
75	71,83	-0,5	2,49	-0,2	3,28	-0,2	1,90	+0,3	0,6	-0,3
80	76,81	-0,5	2,49	-0,2	3,28	-0,2	1,90	+0,3	0,6	-0,3
85	81,81	-0,5			3,28	-0,2	1,90	+0,3	0,6	-0,3
90	86,79	-0,5	2,87	-0,2	3,28	-0,2	2,70	+0,3	0,6	-0,3
95	91,82	-0,5			2,87	-0,2	2,70	+0,3	0,6	-0,3
100	96,80	-0,5	2,87	-0,2	3,28	-0,2	2,70	+0,3	0,6	-0,3
110	106,81	-0,5	2,87	-0,2	3,28	-0,2	2,70	+0,3	0,6	-0,3
115	111,81	-0,5	2,87	-0,2			2,70	+0,3	0,6	-0,3
120	115,21	-0,5			4,06	-0,2	3,10	+0,3	0,6	-0,3
125	120,22	-0,5	2,87	-0,2	4,06	-0,2	3,10	+0,3	0,6	-0,3
130	125,22	-0,5	2,87	-0,2	4,06	-0,2	3,10	+0,3	0,6	-0,3
140	135,23	-0,5	3,71	-0,25	4,90	-0,25	3,10	+0,3	0,6	-0,3
145	140,23	-0,5	3,71	-0,25	4,90	-0,25	3,10	+0,3	0,6	-0,3
150	145,24	-0,5	3,71	-0,25	4,90	-0,25	3,10	+0,3	0,6	-0,3
160	155,22	-0,5	3,71	-0,25	4,90	-0,25	3,10	+0,3	0,6	-0,3
170	163,65	-0,5	3,71	-0,25	5,69	-0,25	3,50	+0,3	0,6	-0,3
180	173,66	-0,5	3,71	-0,25	5,69	-0,25	3,50	+0,3	0,6	-0,3
200	193,65	-0,5	5,69	-0,25	5,69	-0,25	3,50	+0,3	0,6	-0,3

The outer ring chamfer on the side of snap ring groove should allow a housing connection radius of:
 0,3 mm for dimension series 18, up to D = 78 mm included and for dimension series 19, up to D = 47 mm included;
 0,5 mm for dimension series 18, for D > 78 mm and for dimension series 19, for D > 47 mm

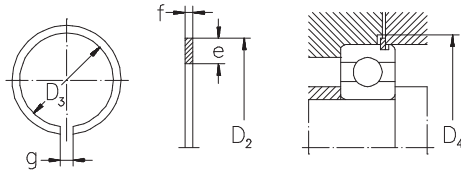

Snap ring

Table 8

Outer diameter	D ₂ ¹⁾	D ₃ ²⁾		D ₄	e	f	g	r	Weight	Snap ring designation	
	max.	nom.	toler.	min.	nom.	nom.	nom.	min.			
D										g	-
mm										g	-
30	34,7	27,9	-0,4	36	3,25	1,12	3	0,4	2,78	SP30	
32	36,7	29,9	-0,4	38	3,25	1,12	3	0,4	2,98	SP32	
35	39,7	32,9	-0,4	41	3,25	1,12	3	0,4	3,22	SP35	
40	44,6	37,8	-0,4	46	3,25	1,12	3	0,4	3,60	SP40	
42	46,3	39,5	-0,5	47	3,25	1,12	3	0,4	3,75	SP42	
47	52,7	44,3	-0,5	54	4,04	1,12	4	0,4	5,30	SP47	
52	57,9	49,4	-0,5	59	4,04	1,12	4	0,4	5,92	SP52	
55	60,7	52,3	-0,5	62	4,04	1,12	4	0,4	6,17	SP55	
62	67,7	59,0	-0,6	69	4,04	1,70	4	0,6	10,5	SP62	
68	74,6	64,2	-0,6	76	4,85	1,70	5	0,6	12,6	SP68	
72	78,6	68,2	-0,6	80	4,85	1,70	5	0,6	14,7	SP72	
75	81,6	71,2	-0,6	83	4,85	1,70	5	0,6	15,3	SP75	
80	86,6	76,2	-0,6	88	4,85	1,70	5	0,6	16,3	SP80	
85	91,6	81,2	-0,6	93	4,85	1,70	5	0,6	17,5	SP85	
90	96,5	86,2	-0,6	98	4,85	2,46	5	0,6	26,6	SP90	
95	101,6	91,2	-0,6	103	4,85	2,46	5	0,6	28,2	SP95	
100	106,5	96,2	-0,8	108	4,85	2,46	5	0,6	29,2	SP100	
110	116,6	106,2	-0,8	118	4,85	2,46	5	0,6	32,8	SP110	
115	121,6	111,2	-0,8	123	4,85	2,46	5	0,6	34,4	SP115	
120	129,7	114,6	-0,8	131	7,21	2,82	7	0,6	60,6	SP120	
125	134,7	119,6	-0,8	136	7,21	2,82	7	0,6	63,0	SP125	
130	139,7	124,6	-0,8	141	7,21	2,82	7	0,6	65,6	SP130	
140	149,7	134,6	-1,2	151	7,21	2,82	7	0,6	70,6	SP140	
145	154,7	139,6	-1,2	156	7,21	2,82	7	0,6	73,0	SP145	
150	159,7	144,5	-1,2	161	7,21	2,82	7	0,6	77,2	SP150	
160	169,7	154,5	-1,2	172	7,21	2,82	7	0,6	81,0	SP160	
170	182,9	162,9	-1,2	185	9,60	3,10	10	0,6	122	SP170	
180	192,9	172,8	-1,2	195	9,60	3,10	10	0,6	128	SP180	
200	212,9	192,8	-1,4	215	9,60	3,10	10	0,6	148	SP200	

1) D₂ dimension refers to the mounted snap ring
 2) D₃ represents dimension before mounting

Deep groove ball bearings

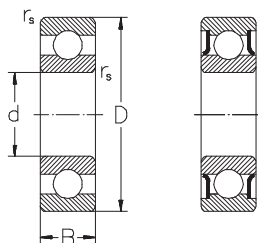

2RSR

Dimensions				Basic radial load		Speed limit		Designation bearing	snap ring	Weight	
d	D	B	r _s min.	dyn. C _r	stat. C _{0r}	grease	oil				
mm				kN		min ⁻¹		-		kg	
3	10	4	0,1	0,64	0,23	40 000	48 000	623		0,002	
	10	4	0,1	0,64	0,23	40 000		623 2ZR		0,002	
4	13	5	0,2	1,3	0,49	38 000	45 000	624		0,003	
	13	5	0,2	1,3	0,49	38 000		624 2ZR		0,003	
	16	5	0,3	1,2	0,5	34 000	40 000	634		0,005	
	16	5	0,3	1,2	0,5	34 000		634 2ZR		0,005	
5	11	3	0,1	0,64	0,26	55 000	65 000	618/5		0,001	
	16	5	0,3	1,9	0,69	34 000	40 000	625		0,005	
	16	5	0,3	1,9	0,69	34 000		625 2ZR		0,005	
	16	5	0,3	1,9	0,69	22 000		625 2RSR		0,005	
	19	6	0,3	1,7	0,72	32 000	38 000	635		0,009	
	19	6	0,3	1,7	0,72	32 000		635 2ZR		0,009	
6	13	3,5	0,1	1	0,44	50 000	59 000	618/6		0,002	
	15	5	0,2	1,45	0,6	47 000	56 000	619/6		0,004	
	19	6	0,3	2,2	0,89	32 000	38 000	626		0,008	
	19	6	0,3	2,2	0,89	32 000		626 2ZR		0,008	
	19	6	0,3	2,2	0,89	22 000		626 2RSR		0,008	
7	14	3,5	0,1	0,96	0,4	47 000	56 000	618/7		0,002	
	17	5	0,3	2,1	0,8	44 000	51 000	619/7Y		0,005	
	19	6	0,3	2,25	0,89	32 000	38 000	607		0,008	
	19	6	0,3	2,25	0,89	32 000		607 2ZR		0,008	
	19	6	0,3	2,25	0,89	22 000		607 2RSR		0,008	
	22	7	0,3	3,3	1,35	30 000	36 000	627		0,012	
	22	7	0,3	3,3	1,35	30 000		627 2ZR		0,012	
	22	7	0,3	3,3	1,35	20 000		627 2RSR		0,012	
	8	16	4	0,2	1,35	0,57	44 000	51 000	618/8		0,003
		19	6	0,3	1,6	0,74	40 000	47 000	619/8		0,007
22		7	0,3	3,3	1,35	30 000	36 000	608		0,015	
22		7	0,3	3,3	1,35	30 000		608 2ZR		0,015	
22		7	0,3	3,3	1,35	20 000		608 2RSR		0,015	
9	17	4	0,2	1,45	0,64	40 000	47 000	618/9		0,003	
	20	6	0,3	2,65	1,1	37 000	43 000	619/9		0,007	
	24	7	0,3	3,35	1,4	30 000	36 000	609		0,018	
	24	7	0,3	3,35	1,4	30 000		609 2ZR		0,018	
	24	7	0,3	3,35	1,4	20 000		609 2RSR		0,018	
	26	8	0,3	4,55	1,95	28 000	34 000	629		0,020	
	26	8	0,3	4,55	1,95	26 000		629 2ZR		0,020	
	26	8	0,3	4,55	1,95	18 000		629 2RSR		0,020	

Deep groove ball bearings

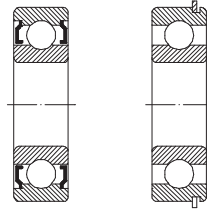

2ZR

NR

Dimensions				Basic radial load		Speed limit		Designation bearing	snap ring	Weight	
d	D	B	r _s min.	dyn. C _r	stat. C _{0r}	grease	oil				
mm				kN		min ⁻¹		-		kg	
10	19	5	0,3	1,7	0,83	37 000	43 000	61800		0,005	
	22	6	0,3	1,95	0,75	34 000	41 000	61900 TN		0,010	
	26	8	0,3	4,55	1,95	28 000	34 000	6000 TN		0,020	
	26	8	0,3	4,55	1,95	28 000		6000 2ZR		0,020	
	26	8	0,3	4,55	1,95	17 000		6000 2RSR		0,020	
	28	8	0,3	4,55	1,95	28 000	34 000	16100		0,023	
	30	9	0,6	5,1	2,4	32 000	38 000	6200TN		0,032	
	30	9	0,6	5,1	2,4	26 000		6200 2ZR		0,032	
	30	9	0,6	5,1	2,4	17 000		6200 2RSR		0,032	
	35	11	0,6	8,1	3,45	20 000	26 000	6300		0,057	
	35	11	0,6	8,1	3,45	20 000		6300 2ZR		0,057	
	35	11	0,6	8,1	3,45	14 000		6300 2RSR		0,057	
	12	21	5	0,3	1,8	0,95	33 000	39 000	61801		0,006
		21	5	0,3	1,45	0,67	33 000	39 000	61801 NR	SR21	0,006
24		6	0,3	2,9	1,45	31 000	36 000	61901		0,011	
24		6	0,3	2,9	1,45	31 000	36 000	61901 NR	SR24	0,011	
28		8	0,3	5,1	2,4	26 000	32 000	6001		0,022	
28		8	0,3	5,1	2,4	26 000	32 000	6001 TN		0,022	
28		8	0,3	5,1	2,4	26 000		6001 2ZR		0,022	
28		8	0,3	5,1	2,4	17 000		6001 2RSR		0,022	
30		8	0,3	5,1	2,4	26 000	32 000	16101		0,026	
32		10	0,6	6,8	3,05	22 000	28 000	6201		0,037	
32		10	0,6	6,8	3,05	22 000	28 000	6201TN		0,037	
32		10	0,6	6,8	3,05	22 000		6201 2ZR		0,037	
32		10	0,6	6,8	3,05	15 000		6201 2RSR		0,037	
32		14	0,6	6,8	3,05	22 000		62201 2RSR		0,049	
37		12	1	9,65	4,15	19 000	24 000	6301		0,065	
37		12	1	9,65	4,15	19 000		6301 2ZR		0,065	
37	12	1	9,65	4,15	12 000		6301 2RSR		0,065		
15	24	5	0,3	2	1,25	28 000	33 000	61802		0,007	
	24	5	0,3	2	1,25	28 000	33 000	61802 NR	SR24	0,007	
	28	7	0,3	4	2,05	26 000	30 000	61902		0,017	
	28	7	0,3	4	2,05	26 000	30 000	61902 NR	SR28	0,017	
	30	8	0,3	4	2,05	22 000	28 000	16002		0,037	
	32	9	0,3	5,6	2,85	22 000	28 000	6002		0,031	
	32	9	0,3	5,6	2,85	22 000		6002 2ZR		0,031	
	32	9	0,3	5,6	2,85	14 000		6002 2RSR		0,031	
	35	11	0,6	7,65	3,75	19 000	24 000	6202		0,046	
	35	11	0,6	7,65	3,75	19 000		6202 2ZR		0,046	

Deep groove ball bearings

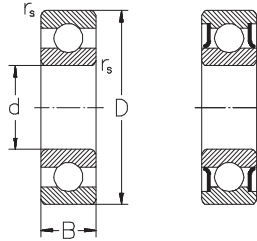

2RSR

Dimensions				Basic radial load		Speed limit		Designation bearing	snap ring	Weight
d	D	B	rs min.	dyn. Cr	stat. Cor	grease	oil			
mm				kN		min ⁻¹		-		kg
15	35	11	0,6	7,65	3,75	19 000		6202 TN		0,046
	35	11	0,6	7,65	3,75	13 000		6202 2RSR		0,046
	35	14	0,6	7,65	3,75	19 000		62202 2RSR		0,053
	42	13	1	11,4	5,45	17 000	20 000	6302		0,092
	42	13	1	11,4	5,45	17 000		6302 2ZR		0,092
	42	13	1	11,4	5,45	11 000		6302 2RSR		0,092
	42	17	1	11,4	5,45	17 000		62302 2RSR		0,099
	17	26	5	0,3	2,2	1,4	26 000	32 000	61803	
30		7	0,3	4,35	2,3	26 000	32 000	61903		0,018
35		8	0,3	6	3,25	20 000	26 000	16003		0,040
35		10	0,3	6	3,25	20 000	26 000	6003		0,042
35		10	0,3	6	3,25	20 000		6003 2ZR		0,042
35		10	0,3	6	3,25	12 000		6003 2RSR		0,042
40		12	0,6	9,55	4,8	17 000	20 000	6203		0,070
40		12	0,6	9,55	4,8	17 000	20 000	6203 TN		0,070
40		12	0,6	9,55	4,8	17 000		6203 2ZR		0,070
40		12	0,6	9,55	4,8	11 000		6203 2RSR		0,070
40		12	0,6	9,55	4,8	17 000	20 000	6203 NR	SP40	0,070
40		16	1	9,55	4,8	17 000	20 000	62203 2RSR		0,082
47		14	1	13,4	6,55	16 000	19 000	6303		0,120
47		14	1	13,4	6,55	16 000		6303 2ZR		0,120
47		14	1	13,4	6,55	11 000		6303 2RSR		0,120
47		19	1	13,4	6,55	16 000		62303 2RSR		0,145
62	17	1,1	22,5	11	12 000	15 000	6403		0,285	
62	17	1,1	22,5	11	12 000	15 000	6403 NR	SP62	0,285	
20	32	7	0,3	3,45	2,25	20 000	26 000	61804		0,020
	32	7	0,3	3,45	2,25	21 000	25 000	61804 NR	SR32	0,020
	37	9	0,3	6,55	3,65	19 000	23 000	61904		0,036
	37	9	0,3	6,55	3,65	19 000	23 000	61904 NR	SR37	0,036
	42	8	0,3	7,95	4,5	17 000	20 000	16004		0,050
	42	12	0,6	9,4	5,05	17 000	20 000	6004		0,070
	42	12	0,6	9,4	5,05	17 000		6004 2ZR		0,070
	42	12	0,6	9,4	5,05	11 000		6004 2RSR		0,070
	47	14	1	12,8	6,65	15 000	18 000	6204		0,118
	47	14	1	12,8	6,65	15 000	18 000	6204 TN		0,118
	47	14	1	12,8	6,65	15 000		6204 2ZR		0,118
	47	14	1	12,8	6,65	10 000		6204 2RSR		0,118
	47	14	1	12,8	6,65	15 000	18 000	6204 NR	SP47	0,118
	47	18	1	12,8	6,65	15 000		62204 2RSR		0,131

Deep groove ball bearings

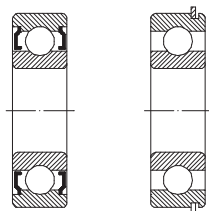

2ZR

NR

Dimensions				Basic radial load		Speed limit		Designation bearing	snap ring	Weight
d	D	B	r _s min.	dyn. C _r	stat. C _{0r}	grease	oil			
mm				kN		min ⁻¹		-		kg
20	52	15	1,1	15,9	7,9	13 000	16 000	6304		0,158
	52	15	1,1	15,9	7,9	13 000	16 000	6304 TN		0,158
	52	15	1,1	15,9	7,9	13 000	16 000	6304 MAP5		0,158
	52	15	1,1	15,9	7,9	13 000		6304 2ZR		0,158
	52	15	1,1	15,9	7,9	8 000		6304 2RSR		0,158
	52	15	1,1	15,9	7,9	13 000	16 000	6304 NR	SP52	0,158
	52	21	1,1	15,9	7,9	13 000		62304 2RSR		0,197
	72	19	1,1	31	15,2	10 000	13 000	6404		0,420
	22	50	14	1	12,9	6,8	15 000	17 000	62/22	
50		14	1	12,9	6,8	15 000		62/22 2ZR		0,118
50		14	1	12,9	6,8	15 000		62/22 2RSR		0,118
56		16	1,1	18,5	9,5	13 000	15 000	63/22		0,201
56		16	1,1	18,5	9,5	13 000		63/22 2ZR		0,201
56		16	1,1	18,5	9,5	13 000		63/22 2RSR		0,201
56		16	1,1	18,5	9,5	13 000		63/22 2RSR		0,201
25	37	7	0,3	4,35	2,6	18 000	25 000	61805		0,022
	42	9	0,3	6,65	4,1	16 000	19 000	61905		0,041
	47	8	0,3	8,4	5,1	15 000	18 000	16005		0,058
	47	12	0,6	10,1	5,85	15 000	18 000	6005 TN		0,086
	47	12	0,6	10,1	5,85	15 000		6005 2ZR		0,086
	47	12	0,6	10,1	5,85	9 500		6005 2RSR		0,086
	52	15	1	14	7,85	12 000	15 000	6205		0,142
	52	15	1	14	7,85	12 000		6205 2ZR		0,142
	52	15	1	14	7,85	8 000		6205 2RSR		0,142
	52	15	1	14	7,85	12 000	15 000	6205 NR	SP52	0,142
	52	18	1	14	7,85	12 000		62205 2RSR		0,148
	62	17	1,1	20,6	11,3	11 000	14 000	6305		0,250
	62	17	1,1	20,6	11,3	11 000	14 000	6305 MAP5		0,250
	62	17	1,1	20,6	11,3	11 000		6305 2ZR		0,250
	62	17	1,1	20,6	11,3	7 500		6305 2RSR		0,250
62	17	1,1	20,6	11,3	11 000	14 000	6305 NR	SP62	0,250	
62	24	1,1	20,6	11,3	11 000		62305 2RSR		0,317	
80	21	1,5	37	18,8	9 000	11 000	6405		0,575	
80	21	1,5	37	18,8	9 000	11 000	6405 NR	SP80	0,575	
28	58	16	1	10,7	6,65	14 000	16 000	62/28		0,173
	58	16	1	10,7	6,65	14 000		62/28 2ZR		0,173
	58	16	1	10,7	6,65	14 000		62/28 2RSR		0,173
	68	18	1,1	19,5	11,5	10 000	12 000	63/28		0,328
	68	18	1,1	19,5	11,5	10 000		63/28 2ZR		0,328

Deep groove ball bearings

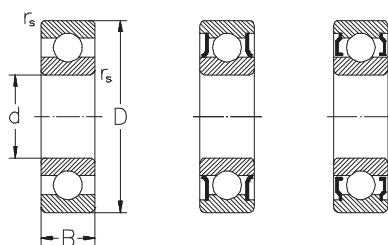

2RSR

2ZR

Dimensions				Basic radial load		Speed limit		Designation bearing	snap ring	Weight
d	D	B	r _s min.	dyn. C _r	stat. C _{0r}	grease	oil			
mm				kN		min ⁻¹		-		kg
28	68	18	1,1	19,5	11,5	10 000		63/28 2RSR		0,328
30	42	7	0,3	4,4	2,9	15 000	18 000	61806		0,027
	42	7	0,3	4,4	2,9	15 000	18 000	61806 NR	SR42	0,027
	47	9	0,3	7,8	4,7	14 000	17 000	61906		0,045
	47	9	0,3	7,8	4,7	14 000	17 000	61906 NR	SR47	0,045
	55	9	3	11,2	7,35	12 000	15 000	16006		0,087
	55	13	1	13,2	8,25	12 000	15 000	6006TN		0,129
	55	13	1	13,2	8,25	12 000		6006 2ZR		0,129
	55	13	1	13,2	8,25	7 000		6006 2RSR		0,129
	55	13	1	13,2	8,25	12 000	15 000	6006 NR	SP55	0,129
	62	16	1	19,5	11,3	10 000	13 000	6206		0,210
	62	16	1	19,5	11,3	10 000		6206 2ZR		0,210
	62	16	1	19,5	11,3	7 500		6206 2RSR		0,210
	62	16	1	19,5	11,3	10 000	10 000	6206 NR	SP62	0,210
	62	20	1	19,5	11,3	10 000		62206 2RSR		0,236
	72	19	1,1	29,9	15,8	9 000	11 000	6306		0,371
	72	19	1,1	29,9	15,8	9 000	11 000	6306 MAP5		0,371
72	19	1,1	29,9	15,8	9 000		6306 2ZR		0,371	
72	19	1,1	29,9	15,8	6 000		6306 2RSR		0,371	
72	19	1,1	29,9	15,8	9 000	11 000	6306 NR	SP72	0,371	
72	27	1,1	26,6	14,9	9 000		62306 2RSR		0,473	
90	23	1,5	47,3	24,5	8 500	10 000	6406		0,785	
90	23	1,5	47,3	24,5	8 500	10 000	6406 NR	SP90	0,785	
32	65	17	1	23	13	10 000	12 000	62/32		0,228
	65	17	1	23	13	10 000		62/32 2ZR		0,228
	65	17	1	23	13	10 000		62/32 2RSR		0,228
	75	20	1,1	30	16	9 000	11 000	63/32		0,437
	75	20	1,1	30	16	9 000		63/32 2ZR		0,437
75	20	1,1	30	16	9 000		63/32 2RSR		0,437	
35	47	7	0,3	4	3,25	13 000	16 000	61807		0,031
	55	10	0,6	9,5	6,2	12 000	14 000	61907		0,073
	62	9	0,3	12,2	8,85	10 000	13 000	16007		0,111
	62	14	1	15,9	10,3	10 000	13 000	6007		0,164
	62	14	1	15,9	10,3	10 000		6007 2ZR		0,164
	62	14	1	15,9	10,3	7 000		6007 2RSR		0,164
	62	14	1	15,9	10,3	10 000	13 000	6007 NR	SP62	0,164
	72	17	1,1	25,7	15,4	9 000	11 000	6207 K		0,315
	72	17	1,1	25,7	15,4	9 000	11 000	6207 TN		0,315

Deep groove ball bearings

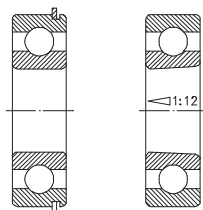

NR

K

Dimensions				Basic radial load		Speed limit		Designation bearing	snap ring	Weight
d	D	B	r _s min.	dyn. C _r	stat. C _{0r}	grease	oil			
mm				kN		min ⁻¹		-		kg
35	72	17	1,1	25,7	15,4	9 000	11 000	6207 MAP6		0,315
	72	17	1,1	25,7	15,4	9 000	11 000	6207 P6		0,315
	72	17	1,1	25,7	15,4	9 000	11 000	6207 P5		0,315
	72	17	1,1	25,7	15,4	9 000		6207 2ZR		0,315
	72	17	1,1	25,7	15,4	6 000		6207 2RSR		0,315
	72	17	1,1	25,7	15,4	9 000	11 000	6207 NR	SP72	0,315
	72	17	1,1	25,7	15,4	9 000	11 000	6207 NRP6	SP72	0,315
	72	17	1,1	25,7	15,4	9 000	11 000	6207 MA		0,315
	72	23	1,1	25,7	15,4	9 000		62207 2RSR		0,375
	80	21	1,5	33,5	18,3	8 500	10 000	6307		0,450
	80	21	1,5	33,5	18,3	8 500	10 000	6307 K		0,450
	80	21	1,5	33,5	18,3	8 500	10 000	6307 P6		0,450
	80	21	1,5	33,5	18,3	8 500	10 000	6307 P5		0,450
	80	21	1,5	33,5	18,3	8 500		6307 2ZR		0,450
	80	21	1,5	33,5	18,3	8 500		6307 2ZRP5		0,450
	80	21	1,5	33,5	18,3	5 600		6307 2RSR		0,450
	80	21	1,5	33,5	18,3	5 600		6307 2RSRP6		0,450
	80	21	1,5	33,5	18,3	5 600		6307 2RSRP5		0,450
	80	21	1,5	33,5	18,3	8 500	10 000	6307 NR	SP80	0,450
	80	31	1,5	33,5	18,3	8 500		62307 2RSR		0,658
100	25	1,5	55,5	29,4	7 000	8 500	6407		0,954	
100	25	1,5	55,5	29,4	7 000	8 500	6407 NR	SP100	0,954	
40	52	7	0,3	4,5	4,05	11 000	14 000	61808 P5		0,034
	52	7	0,3	4,5	4,05	12 000	14 000	61808 NR	SR52	0,034
	62	12	0,6	14,5	10,2	11 000	13 000	61908		0,110
	62	12	0,6	14,5	10,2	11 000	13 000	61908 NR	SR62	0,110
	68	9	0,3	13,3	9,8	9 500	12 000	16008		0,130
	68	15	1	16,8	11,6	9 500	12 000	6008		0,210
	68	15	1	16,8	11,6	9 500		6008 2ZR		0,210
	68	15	1	16,8	11,6	6 000		6008 2RSR		0,210
	68	15	1	16,8	11,6	9 500	12 000	6008 NR	SP68	0,210
	80	18	1,1	32	17,8	8 500	10 000	6208		0,402
	80	18	1,1	32	17,8	8 500	10 000	6208 K		0,402
	80	18	1,1	32	17,8	8 500	10 000	6208 P6		0,402
	80	18	1,1	32	17,8	8 500	10 000	6208 P5		0,402
	80	18	1,1	32	17,8	8 500		6208 2ZR		0,402
	80	18	1,1	32	17,8	8 500		6208 2ZRP5		0,402
	80	18	1,1	32	17,8	5 600		6208 2RSR		0,402
	80	18	1,1	32	17,8	5 600		6208 2RSRP5		0,402

Deep groove ball bearings

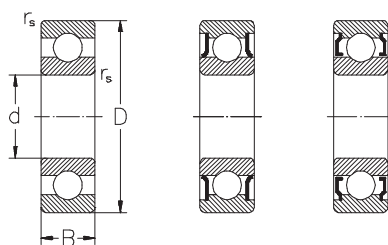

2RSR

2ZR

Dimensions				Basic radial load		Speed limit		Designation	snap ring	Weight
d	D	B	r _s min.	dyn. C _r	stat. C _{0r}	grease	oil	bearing		
mm				kN		min ⁻¹		–	kg	
40	80	18	1,1	32	17,8	8 500	10 000	6208 NR	SP80	0,402
	80	18	1,1	32	17,8	8 500	10 000	6208 MB		0,402
	80	18	1,1	32	17,8	8 500	10 000	6208 NMA	0,402	
	80	23	1,1	32	19,8	8 500		62208 2RSR	0,460	
	90	23	1,5	40,7	24	7 500	9 000	6308	0,635	
	90	23	1,5	40,7	24	7 500	9 000	6308 K	0,635	
	90	23	1,5	40,7	24	7 500	9 000	6308 TN	0,635	
	90	23	1,5	40,7	24	7 500	9 000	6308 P6	0,635	
	90	23	1,5	40,7	24	7 500	9 000	6308 P5	0,635	
	90	23	1,5	40,7	24	7 500		6308 2ZR	0,635	
	90	23	1,5	40,7	24	7 500		6308 2ZRP5	0,635	
	90	23	1,5	40,7	24	5 000		6308 2RSR	0,635	
	90	23	1,5	40,7	24	7 500	9 000	6308 NMA	0,635	
	90	23	1,5	40,7	24	7 500	9 000	6308 NR	0,635	
90	33	1,5	40,7	24	7 500		62308 2RSR	0,874		
110	27	2	64	35	6 700	7 500		6408		1,23
	110	27	2	64	35	6 700	8 000	6408 NR	SP110	1,23
45	58	7	0,3	6,4	5,6	9 500	12 000	61809		0,043
	68	12	0,6	14	9,8	9 700	11 000	61909		0,120
	75	10	0,6	15,5	12,3	9 000	11 000	16009		0,170
	75	16	1	21	15	9 000	11 000	6009		0,261
	75	16	1	21	15	9 000	11 000	6009 P5		0,261
	75	16	1	21	15	9 000	11 000	6009 P4		0,261
	75	16	1	21	15	9 000		6009 2ZR		0,261
	75	16	1	21	15	9 000		6009 2ZRP4		0,261
	75	16	1	21	15	5 600		6009 2RSR		0,261
	75	16	1	21	15	9 000	11 000	6009 NR	SP75	0,261
	85	19	1,1	32,7	20,2	7 500	9 000	6209		0,414
	85	19	1,1	32,7	20,2	7 500	9 000	6209 K		0,414
	85	19	1,1	32,7	20,2	7 500	9 000	6209 P6		0,414
	85	19	1,1	32,7	20,2	7 500	9 000	6209 P5		0,414
	85	19	1,1	32,7	20,2	8 000		6209 2ZR		0,414
	85	19	1,1	32,7	20,2	8 000		6209 2ZRP5		0,414
	85	19	1,1	32,7	20,2	5 300		6209 2RSR		0,414
	85	19	1,1	32,7	20,2	5 300		6209 2RSRP6		0,414
85	19	1,1	32,7	20,2	5 300		6209 2RSRP5		0,414	
85	19	1,1	32,7	20,2	8 000	9 500	6209 NR	SP85	0,414	
85	23	1,1	32,7	20,2	8 000		62209 2RSR		0,481	
100	25	1,5	52,8	31,7	6 700	8 000	6309		0,838	

Deep groove ball bearings

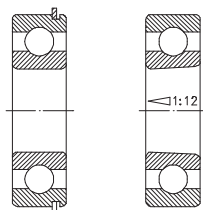

NR

K

Dimensions				Basic radial load		Speed limit		Designation bearing	snap ring	Weight
d	D	B	r _s min.	dyn. C _r	stat. C _{0r}	grease	oil			
mm				kN		min ⁻¹		-		kg
45	100	25	1,5	52,8	31,7	6 700	8 000	6309 K 6309 MB 6309 MAP6 6309 P6 6309 P5		0,838 0,838 0,838 0,838 0,838
	100	25	1,5	52,8	31,7	6 700	8 000			
	100	25	1,5	52,8	31,7	6 700	8 000			
	100	25	1,5	52,8	31,7	6 700	8 000			
	100	25	1,5	52,8	31,7	6 700	8 000			
	100	25	1,5	52,8	31,7	6 700	8 000			
	100	25	1,5	52,8	31,7	6 700	8 000	6309 ZZR 6309 ZZRP5		0,838 0,838
	100	25	1,5	52,8	31,7	6 700	8 000			
	100	25	1,5	52,8	31,7	4 500	8 000	6309 2RSR 6309 2RSRP6 6309 2RSRP5		0,838 0,838
	100	25	1,5	52,8	31,7	4 500	8 000			
	100	25	1,5	52,8	31,7	6 700	8 000	6309 NR 62309 2RSR	SP100	0,838 1,18
	100	36	1,5	52,8	31,7	6 700	6 700			
	120	29	2	76,8	44,9	5 600	6 700	6409 6409 NR	SP120	1,54 1,54
	120	29	2	76,8	44,9	5 600	6 700			
50	65	7	0,3	6,8	6,3	9 500	12 000	61810 61810 NR	SR65	0,057 0,057
	65	7	0,3	6,8	6,3	9 700	11 000			
	72	12	0,6	14,5	10,4	9 000	11 000	61910 61910 NR	SR72	0,130 0,130
	72	12	0,6	14,5	10,4	9 000	11 000			
	80	10	0,6	16,3	13,1	8 500	10 000	16010 6010 K		0,188 0,260
	80	16	1	21,8	16,5	8 500	10 000			
	80	16	1	21,8	16,5	8 500	8 500	6010 2ZR 6010 2RSR		0,260 0,260
	80	16	1	21,8	16,5	5 300	8 500			
	90	20	1,1	35,1	23,1	7 000	8 500	6210 6210 K		0,460 0,460
	90	20	1,1	35,1	23,1	7 000	8 500			
	90	20	1,1	35,1	23,1	7 000	8 500	6210 M 6210 MAP6		0,460 0,460
	90	20	1,1	35,1	23,1	7 000	8 500			
	90	20	1,1	35,1	23,1	7 000	8 500	6210 P6 6210 P5		0,460 0,460
	90	20	1,1	35,1	23,1	7 000	8 500			
	90	20	1,1	35,1	23,1	7 000	8 500	6210 ZZR 6210 2ZR		0,460 0,460
	90	20	1,1	35,1	23,1	7 000	8 500			
	90	20	1,1	35,1	23,1	7 000	8 500	6210 2ZR 6210 2RSR		0,460 0,460
	90	20	1,1	35,1	23,1	4 500	8 500			
	90	20	1,1	35,1	23,1	4 500	8 500	6210 2RSRP6 6210 2RSRP5		0,460 0,460
	90	20	1,1	35,1	23,1	4 500	8 500			
	90	20	1,1	35,1	23,1	7 000	8 500	6210 NR 62210 2RSR	SP90	0,460 0,514
	90	23	1,1	35,1	23,1	7 000	7 000			
110	27	2	61,8	37,9	6 000	7 000	6310 6310 K		1,06 1,06	
110	27	2	61,8	37,9	6 000	7 000				
110	27	2	61,8	37,9	6 000	7 000	6310 MAP6 6310 ZZR		1,06 1,06	
110	27	2	61,8	37,9	6 000	7 000				

Deep groove ball bearings

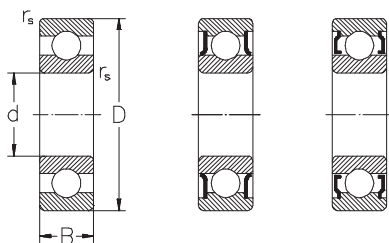

2RSR

2ZR

Dimensions				Basic radial load		Speed limit		Designation bearing	snap ring	Weight
d	D	B	rs min.	dyn. Cr	stat. Cor	grease	oil			
mm				kN		min ⁻¹		-		kg
50	110	27	2	61,8	37,9	4 000		6310 2RSR		1,06
	110	27	2	61,8	37,9	6 000	7 000	6310 NR	SP110	1,06
	110	40	2	61,8	37,9	6 000		62310 2RSR		1,65
	130	31	2,1	87,1	52	5 000	6 000	6410		1,89
	130	31	2,1	87,1	52	5 000	6 000	6410 NR	SP130	1,89
55	72	9	0,3	9	8,5	8 500	10 000	61811		0,083
	90	11	0,6	19,3	16,3	7 500	9 000	16011		0,26
	90	18	1,1	28,3	21,2	7 500	9 000	6011 MB		0,39
	90	18	1,1	28,3	21,2	7 500		6011 2ZR		0,39
	90	18	1,1	28,3	21,2	4 500		6011 2RSR		0,39
	90	18	1,1	28,3	21,2	7 500	9 000	6011 NR	SP90	0,39
	100	21	1,5	43,4	29,3	6 300	7 500	6211		0,611
	100	21	1,5	43,4	29,3	6 300	7 500	6211 K		0,611
	100	21	1,5	43,4	29,3	6 300	7 500	6211 MA		0,611
	100	21	1,5	43,4	29,3	6 300		6211 2ZR		0,611
	100	21	1,5	43,4	29,3	4 000		6211 2RSR		0,611
	100	21	1,5	43,4	29,3	6 300	7 500	6211 NR	SP100	0,611
	120	29	2	71,5	44,6	5 300	6 300	6311		1,38
	120	29	2	71,5	44,6	5 300	6 300	6311 K		1,38
	120	29	2	71,5	44,6	5 300	6 300	6311 MA		1,38
120	29	2	71,5	44,6	5 300		6311 2ZR		1,38	
120	29	2	71,5	44,6	3 600		6311 2RSR		1,38	
120	29	2	71,5	44,6	5 300	6 300	6311 NR	SP120	1,38	
140	33	2,1	100	62	4 800	5 600	6411		2,30	
140	33	2,1	100	62	4 800	5 600	6411 NR	SP140	2,30	
60	78	10	0,3	8,7	6,7	8 000	9 500	61812		0,120
	95	11	0,6	20	17,6	7 000	8 500	16012		0,280
	95	18	1,1	29,4	23,2	6 700	8 000	6012		0,420
	95	18	1,1	29,4	23,2	6 700		6012 2ZR		0,420
	95	18	1,1	29,4	23,2	4 300		6012 2RSR		0,420
	95	18	1,1	29,4	23,2	7 000	8 500	6012 NR	SP95	0,420
	110	22	1,5	52,4	36	6 000	7 000	6212		0,780
	110	22	1,5	52,4	36	6 000	7 000	6212 K		0,780
	110	22	1,5	52,4	36	6 000	7 000	6212 MA		0,780
	110	22	1,5	52,4	36	6 000		6212 2ZR		0,780
	110	22	1,5	52,4	36	4 000		6212 2RSR		0,780
	110	22	1,5	52,4	36	6 000	7 000	6212 NR	SP110	0,780
	130	31	2,1	81,8	51,9	5 000	6 000	6312		1,72
	130	31	2,1	81,8	51,9	5 000	6 000	6312 K		1,72
	130	31	2,1	81,8	51,9	5 000		6312 2ZR		1,72

Deep groove ball bearings

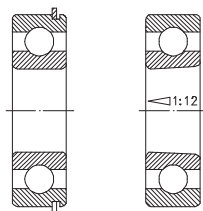

NR

K

Dimensions				Basic radial load		Speed limit		Designation bearing	snap ring	Weight
d	D	B	r _s min.	dyn. C _r	stat. C _{0r}	grease	oil			
mm				kN		min ⁻¹		-		kg
60	130	31	2,1	81,8	51,9	3 400		6312 2RSR		1,72
	130	31	2,1	81,8	51,9	5 000	6 000	6312 NR	SP130	1,72
	150	35	2,1	110	70,8	4 300		6412		2,76
	150	35	2,1	110	70,8	4 300	5 000	6412 NR	SP150	2,76
62	110	22	1,5	47,5	28	6 000	7 000	62/62		0,600
65	85	10	0,6	12,2	12	7 000	8 500	61813		0,130
	100	11	0,6	22,9	19,6	6 300	7 500	16013		0,300
	100	18	1,1	30,5	25,2	6 300	7 500	6013 K		0,440
	100	18	1,1	30,5	25,2	6 300		6013 2ZR		0,440
	100	18	1,1	30,5	25,2	4 000		6013 2RSR		0,440
	100	18	1,1	30,5	25,2	6 300	7 500	6013 NR	SP100	0,440
	120	23	1,5	57,2	40	5 300	6 300	6213		0,995
	120	23	1,5	57,2	40	5 300	6 300	6213 M		0,995
	120	23	1,5	57,2	40	5 300	6 300	6213 MA		0,995
	120	23	1,5	57,2	40	5 300		6213 2ZR		0,995
	120	23	1,5	57,2	40	3 600		6213 2RSR		0,995
	120	23	1,5	57,2	40	5 300	6 300	6213 NR	SP120	0,995
	140	33	2,1	92,7	59,7	4 800	5 600	6313		2,10
	140	33	2,1	92,7	59,7	4 800	5 600	6313 MA		2,10
	140	33	2,1	92,7	59,7	4 800	5 600	6313 MB		2,10
	140	33	2,1	92,7	59,7	4 800		6313 2ZR		2,10
140	33	2,1	92,7	59,7	3 000		6313 2RSR		2,10	
140	33	2,1	92,7	59,7	4 800	5 600	6313 NR	SP140	2,10	
160	37	2,1	118	79	4 000	4 800	6413		3,300	
160	37	2,1	118	79	4 000	4 800	6413 NR	SP160	3,300	
70	90	10	0,6	12,5	10	6 700	8 000	61814		0,160
	110	13	0,6	27,9	25	6 000	7 000	16014		0,433
	110	20	1,1	38,1	30,9	6 000	7 000	6014		0,600
	110	20	1,1	38,1	30,9	6 000	7 000	6014 MAP5		0,600
	110	20	1,1	38,1	30,9	6 000		6014 2ZR		0,600
	110	20	1,1	38,1	30,9	3 600		6014 2RSR		0,600
	110	20	1,1	38,1	30,9	6 000	7 000	6014 NR	SP110	0,600
	125	24	1,5	62,2	44,1	5 000	6 000	6214		1,07
	125	24	1,5	62,2	44,1	5 000	6 000	6214 MA		1,07
	125	24	1,5	62,2	44	5 000		6214 2ZR		1,07
	125	24	1,5	62,2	44	3 400		6214 2RSR		1,07
	125	24	1,5	62,2	44	5 000	6 000	6214 NR	SP125	1,07
	150	35	2,1	104	68,1	4 500	5 300	6314		2,50
	150	35	2,1	104	68,1	4 500	5 300	6314 K		2,50

Deep groove ball bearings

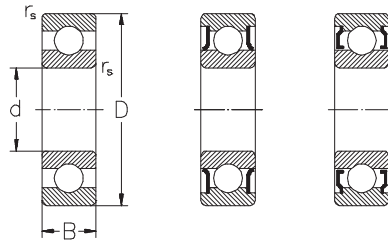

2RSR

2ZR

Dimensions				Basic radial load		Speed limit		Designation bearing	snap ring	Weight
d	D	B	r _s min.	dyn. C _r	stat. C _{0r}	grease	oil			
mm				kN		min ⁻¹		-		kg
70	150	35	2,1	104	68,1	4 500	5 300	6314 MAP6	SP150	2,50
	150	35	2,1	104	68,1	4 500		6314 2ZR		2,50
	150	35	2,1	104	68,1	2 800		6314 2RSR		2,50
	150	35	2,1	104	68,1	4 500	5 300	6314 NR		2,50
	180	42	3	144	104	3 800	4 500	6414		4,85
75	95	10	0,6	12,8	12,1	6 300	7 500	61815 P5	SP115	0,160
	95	10	0,6	12,8	12,1	4 000		61815 2RSR		0,160
	115	13	0,6	28,5	26,8	5 600	6 700	16015		0,460
	115	20	1,1	39,7	33,5	5 600	6 700	6015 M		0,640
	115	20	1,1	39,7	33,5	5 600	6 700	6015 MAP5		0,640
	115	20	1,1	39,7	33,5	5 600		6015 2ZR		0,640
	115	20	1,1	39,7	33,5	3 400		6015 2RSR		0,640
	115	20	1,1	39,7	33,5	5 600	6 700	6015 NR		0,640
	130	25	1,5	67,4	49,3	4 800	5 600	6215		1,18
	130	25	1,5	67,4	49,3	4 800	5 600	6215 K		1,18
	130	25	1,5	67,4	49,3	4 800		6215 2ZR		1,18
	130	25	1,5	67,4	49,3	3 200		6215 2RSR		1,18
	130	25	1,5	67,4	49,3	4 800	5 600	6215 NR		1,18
	160	37	2,1	113	77	4 000	4 800	6315		3,03
	160	37	2,1	113	77	4 000	4 800	6315 MP6		3,03
	160	37	2,1	113	77	4 000		6315 2ZR		3,03
	160	37	2,1	113	77	2 800		6315 2RSR		3,03
	160	37	2,1	113	77	4 000	5 000	6315 NR		3,03
	190	45	3	154	115	3 600	4 300	6415		6,50
80	100	10	0,6	12,9	13,7	6 000	7 000	61816	SP125	0,160
	110	16	1	25,1	20,5	5 600	6 700	61916		0,380
	125	14	0,6	31,9	29,7	5 300	6 300	16016		0,600
	125	22	1,1	47,6	39,8	5 300	6 300	6016 MA		0,850
	125	22	1,1	47,6	39,8	5 300		6016 2ZR		0,850
	125	22	1,1	47,6	39,8	3 600		6016 2RSR		0,850
	125	22	1,1	47,6	39,8	5 300	6 300	6016 NR		0,850
	140	26	2	72,7	53	4 500	5 300	6216		1,40
	140	26	2	72,7	53	4 500	5 300	6216 K		1,40
	140	26	2	72,7	53	4 500	5 300	6216 MA		1,40
	140	26	2	72,7	53	4 500		6216 2ZR		1,40
	140	26	2	72,7	53	3 000		6216 2RSR		1,40
	140	26	2	72,7	53	4 500	5 300	6216 NR		1,40
	170	39	2,1	123	86,5	3 800	4 500	6316 K		3,60
	170	39	2,1	123	86,5	3 800	4 500	6316 M		3,60

Deep groove ball bearings

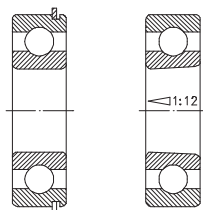

NR

K

Dimensions				Basic radial load		Speed limit		Designation bearing	snap ring	Weight
d	D	B	r _s min.	dyn. C _r	stat. C _{0r}	grease	oil			
mm				kN		min ⁻¹		-		kg
80	170	39	2,1	123	86,5	3 800		6316 ZZR		3,60
	170	39	2,1	123	86,5	3 800	4 500	6316 NR	SP170	3,60
	200	48	3	164	125	3 400	4 000	6416		7,50
85	110	13	1	19,3	20	5 300	6 300	61817		0,290
	130	14	1	33,8	33,5	5 000	6 000	16017		0,630
	130	22	1,1	49,5	43,1	5 000	6 000	6017		0,890
	130	22	1,1	49,5	43,1	5 000		6017 ZZR		0,890
	130	22	1,1	49,5	43,1	3 400		6017 2RSR		0,890
	130	22	1,1	49,5	43,1	5 000	6 000	6017 NR	SP130	0,890
	150	28	2	84	61,9	4 300	5 000	6217		1,80
	150	28	2	84	61,9	4 300	5 000	6217 K		1,80
	150	28	2	84	61,9	4 300	5 000	6217 MP6		1,80
	150	28	2	84	61,9	4 300		6217 ZZR		1,80
	150	28	2	84	61,9	2 800		6217 2RSR		1,80
	150	28	2	84	61,9	4 300	5 000	6217 NR	SP150	1,80
	180	41	3	133	96,6	3 600	4 300	6317		4,20
	180	41	3	133	96,6	3 600	4 300	6317 K		4,20
	180	41	3	133	96,6	3 600	4 300	6317 MA		4,20
	180	41	3	133	96,6	3 600	4 300	6317 MB		4,20
	180	41	3	133	96,6	3 600		6317 ZZR		4,20
	180	41	3	133	96,6	3 600	4 300	6317 NR	SP180	4,20
210	52	4	173	136	3 200	3 800	6417		9,00	
90	115	13	1	19,6	20,4	5 300	6 300	61818		0,300
	140	16	1	41,9	40,4	4 500	5 300	16018		0,850
	140	24	1,5	58,2	49,7	4 500	5 300	6018 MA		1,16
	140	24	1,5	58,2	49,7	4 500	5 300	6018 MP6		1,16
	140	24	1,5	58,2	49,7	4 500		6018 ZZR		1,16
	140	24	1,5	58,2	49,7	3 000		6018 2RSR		1,16
	140	24	1,5	58,2	49,7	4 500	5 600	6018 NR	SP140	1,16
	160	30	2	96	71,5	3 800	4 500	6218		2,16
	160	30	2	96	71,5	3 800	4 500	6218 K		2,16
	160	30	2	96	71,5	3 800	4 500	6218 MA		2,16
	160	30	2	96	71,5	3 800	4 500	6218 MP6		2,16
	160	30	2	96	71,5	3 800		6218 ZZR		2,16
	160	30	2	96	71,5	3 800	4 500	6218 NR	SP160	2,16
	190	43	3	143	107	3 400	4 000	6318		4,90
	190	43	3	143	107	3 400	4 000	6318 K		4,90
190	43	3	143	107	3 400	4 000	6318 M		4,90	
190	43	3	143	107	3 400		6318 ZZR		4,90	

Deep groove ball bearings

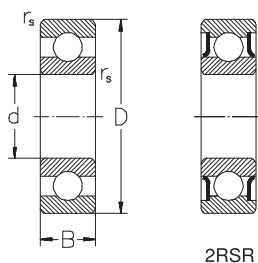

2RSR

Dimensions				Basic radial load		Speed limit		Designation bearing	snap ring	Weight	
d	D	B	r_s min.	dyn. C_r	stat. C_{0r}	grease	oil				
mm				kN		min^{-1}		-		kg	
90	190	43	3	143	107	3 400	4 000	6318 NR 6418 16019 6019	SP190	4,90	
	225	54	4	190	160	3 000	3 600			11,5	
	145	16	1	42,3	41,5	4 300	5 000			0,890	
	145	24	1,5	60,5	53,6	4 300	5 000			1,20	
95	145	24	1,5	60,5	53,6	4 300		6019 2ZR 6019 2RSR	SP145	1,20	
	145	24	1,5	60,5	53,6	2 800				1,20	
	145	24	1,5	60,5	53,6	4 300	5 000	6019 NR 6219 MBP6 6219 NR	SP170	1,20	
	170	32	2,1	109	81,9	3 600	4 300			2,60	
	170	32	2,1	109	81,9	3 600	4 300			2,60	
	200	45	3	153	118	3 200	3 800	6319 6319 MAP6		5,60	
	200	45	3	153	118	3 200	3 800			5,60	
	100	125	13	1	19,6	21,2	4 800	5 600	61820 MAP5 16020 6020 MAP6 6020 2ZR 6020 2RSR		0,320
150		16	1	45	44	4 300	5 000			0,910	
150		24	1,5	60,5	54	4 300	5 000			1,25	
150		24	1,5	60,5	54	4 300				1,25	
150		24	1,5	60,5	54	2 800				1,25	
150		24	1,5	60,5	54	4 300	5 000	6020 NR 6220 6220 MA 6220 MP6 6220 NR	SP150	1,25	
180		34	2,1	124	93	3 400	4 000				3,10
180		34	2,1	124	93	3 400	4 000				3,15
180		34	2,1	124	93	3 400	4 000				3,15
180		34	2,1	124	93	3 400	4 000			3,15	
215		47	3	173	140	3 000		6320 2ZR 6320 MAP6		7,00	
215		47	3	173	140	3 000	3 600			7,00	
105	130	13	1	20,8	19,6	4 500	5 300	61821 MAP5 16021 6021 M 6221 6221 MA		0,350	
	160	18	1	52	51	4 000	4 800			1,20	
	160	26	2	72,3	65,8	3 800	4 500			1,60	
	190	36	2,1	133	104	3 200	3 800			3,70	
	190	36	2,1	133	104	3 200	3 800		3,70		
	225	49	3	184	153	2 800	3 400	6321 MA		8,00	
110	140	16	1	28,1	29	4 300	5 000	61822 16022 6022		0,600	
	170	19	1	57,5	56,7	3 800	4 500			1,46	
	170	28	2	82	73	3 600	4 300			1,95	
	200	38	2,1	143	118	3 000	3 600	6222 6222 M		4,35	
	200	38	2,1	143	118	3 000	3 600			4,35	
	200	38	2,1	143	118	3 000	3 600			4,35	
	200	38	2,1	143	118	3 000	3 600	6222 NR 6322 6322 MA	SP200	4,35	
	240	50	3	203	178	2 600	3 200				9,58
	240	50	3	203	178	2 600	3 200				9,58

Deep groove ball bearings

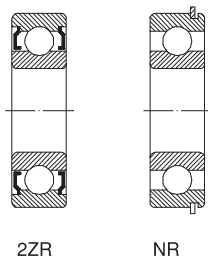

2ZR

NR

Dimensions				Basic radial load		Speed limit		Designation bearing	snap ring	Weight
d	D	B	r _s min.	dyn. C _r	stat. C _{0r}	grease	oil			
mm				kN		min ⁻¹		-		kg
120	150	16	1	29,1	32,5	3 800	4 500	61824	SP215	0,650
	180	19	1	63,2	63,3	3 400	4 000	16024		1,70
	180	28	2	85	79,3	3 400	4 000	6024 MP6		2,09
	215	40	2,1	155	131	2 800	3 400	6224		5,15
	215	40	2,1	155	131	2 800	3 400	6224 MB		5,15
	215	40	2,1	155	131	2 800	3 400	6224 MAP6		5,15
	215	40	2,1	155	131	2 800	2 800	6224 ZZR		5,15
	215	40	2,1	155	131	2 800	3 400	6224 NR		5,15
	260	55	3	212	190	2 400	3 000	6324 MA		13,6
	130	165	18	1,1	38	43	3 600	4 300		61826 MAP5
200		22	1,1	79	81	3 200	3 800	16026	2,50	
200		33	2	106	101	3 000	3 600	6026	3,25	
230		40	3	167	146	2 600	3 200	6226	6,00	
230		40	3	167	146	2 600	3 200	6226 M	6,00	
280		58	4	229	214	2 200	2 800	6326 MA	17,0	
140		175	18	1,1	39	46	3 400	4 000	61828 MAP5	SP215
	210	22	1,1	80,5	86	2 800	3 400	16028	2,70	
	210	33	2	110	109	2 800	3 400	6028 MP6	3,35	
	250	42	3	176	164	2 400	3 000	6228	7,50	
	250	42	3	176	164	2 400	3 000	6228 MA	7,50	
	300	62	4	253	246	2 000	2 600	6328 MA	21,0	
150	190	20	1,1	48,8	61	3 000	3 600	61830	SP215	1,40
	225	24	1,1	92,3	98	2 600	3 200	16030		3,40
	225	35	2,1	125	126	2 600	3 200	6030 MA		4,75
	270	45	3	176	170	2 000	2 600	6230 MA		9,60
	320	65	4	275	284	1 900	2 400	6330 MA		25,0
160	200	20	1,1	52	62	2 800	3 400	61832	SP215	1,49
	240	25	1,5	99,4	107	2 400	3 000	16032		3,60
	240	38	2,1	140	143	2 400	3 000	6032 MA		5,85
	290	48	3	185	186	1 900	2 400	6232 MA		15,0
170	215	22	1,1	61,8	73,5	2 600	3 200	61834 P6	SP215	2,00
	260	28	1,5	118	127	2 200	2 800	16034		5,70
	260	42	2,1	168	172	2 200	2 800	6034 MA		7,80
	310	52	4	212	224	1 900	2 400	6234 MA		17,5
	180	225	22	1,1	62,3	78,5	2 400	3 000		61836 P5
250		33	2	128	137	2 200	2 800	61936 MA	4,90	
280		31	2	140	146	2 000	2 600	16036 MA	7,00	
280		46	2,1	186	194	2 000	2 600	6036	10,5	
320		52	4	227	242	1 800	2 200	6236	18,5	

Deep groove ball bearings

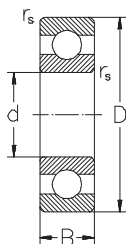

Dimensions				Basic radial load		Speed limit		Designation bearing	snap ring	Weight
d	D	B	r _s min.	dyn. C _r	stat. C _{0r}	grease	oil			
mm				kN		min ⁻¹		-		kg
190	240	24	1,5	74,1	92	2 200	2 800	61838 16038 6038 MA		2,60
	290	31	2	148	162	2 000	2 600			7,90
	290	46	2,1	194	210	2 000	2 600			11,0
	290	46	2,1	194	210	2 000	2 600	6038 MB 6038 MBP6		11,0
	290	46	2,1	194	210	2 000	2 600			11,0
	290	46	2,1	194	210	2 000	2 600	6038 MBP5 6238 MA 6238 MB		11,0
	340	55	4	255	278	1 700	2 000			23,0
	340	55	4	255	278	1 700	2 000			23,0
	200	250	24	1,5	78	93	2 200	2 800	61840 MB 61940 MB 16040 MBP6	
280		38	2,1	151	160	2 200	2 800	7,25		
310		34	2	168	187	1 900	2 400	9,00		
310		34	2	168	187	1 900	2 400	16040 MBP5 6040 MA		9,00
310		51	2,1	208	226	1 900	2 400			13,5
310		51	2,1	208	226	1 900	2 400	6040 MB 6040 MBP52 6240 M 6240 MB		13,5
310		51	2,1	208	226	1 900	2 400			13,5
360		58	4	280	314	1 700	2 000			28,0
360		58	4	280	314	1 700	2 000			27,0

Stainless steel deep groove ball bearings

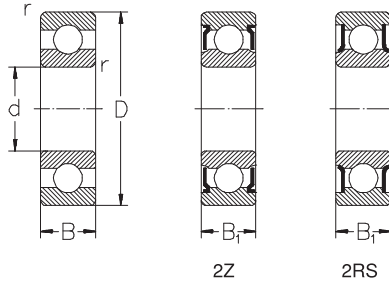

Dimensions					Basic radial load		Designation		
d	D	B	B ₁	r min.	dyn. C _r	stat. C _{0r}	opened	shielded	sealed
mm					kN		—		
3	8	3	4	0,15	560	179	S619/3	S619/3 ZZ	
	10	4	4	0,15	630	218	S623	S623 ZZ	
	13	5	5	0,2	1300	485	S633	S633 ZZ	
4	9	2,5	4	0,1	640	225	S618/4	S618/4 ZZ	
	11	4	4	0,15	960	345	S619/4	S619/4 ZZ	
	12	4	4	0,2	960	345	S604	S604 ZZ	
	13	5	5	0,2	1300	485	S624	S624 ZZ	
	16	5	5	0,3	1730	670	S634	S634 ZZ	
5	11	3	5	0,15	715	281	S618/5	S618/5 ZZ	
	13	4	4	0,2	1080	430	S619/5	S619/5 ZZ	
	14	5	5	0,2	1330	505	S605	S605 ZZ	
	16	5	5	0,3	1730	670	S625	S625 ZZ	S625 2RS
	19	6	6	0,3	2340	885	S635	S635 ZZ	S635 2RS
6	13	3,5	5	0,15	1080	440	S618/6	S618/6 ZZ	S618/6 2RS
	15	5	5	0,2	1730	670	S619/6	S619/6 ZZ	S619/6 2RS
	17	6	6	0,3	2260	835	S606	S606 ZZ	S606 2RS
	19	6	6	0,3	2340	885	S626	S626 ZZ	S626 2RS
	22	7	7	0,3	3300	1370	S636	S636 ZZ	S636 2RS
7	14	3,5	5	0,15	1170	510	S618//7	S618/7 ZZ	S618/7 2RS
	17	5	5	0,3	1610	710	S619/7	S619/7 ZZ	S619/7 2R
	19	6	6	0,3	2340	885	S607	S607 ZZ	S607 2RS
	22	7	7	0,3	3300	1370	S627	S627 ZZ	S627 2RS
	26	9	9	0,3	4050	1620	S637	S637 ZZ	S637 2RS
8	16	4	5	0,2	1260	590	S618/8	S618/8ZZ	S618/8 2RS
	19	6	6	0,3	2240	910	S619/8	S619/8ZZ	S619/8 2RS
	22	7	7	0,3	3300	1370	S608	S608ZZ	S608 2RS
	24	8	8	0,3	3350	1430	S628	S628ZZ	S628 2RS
	28	9	9	0,3	4550	1970	S638	S638ZZ	S638 2RS
9	17	4	5	0,2	1330	665	S618/9	S618/9ZZ	S618/9 2RS
	20	6	6	0,3	1720	840	S619/9	S619/9ZZ	S619/9 2RS
	24	7	7	0,3	3350	1430	S609	S609ZZ	S609 2RS
	26	8	8	0,3	4550	1970	S629	S629 ZZ	S629 2RS
	30	10	10	0,6	5100	2390	S639	S639 ZZ	S639 2RS

Stainless steel deep groove ball bearings

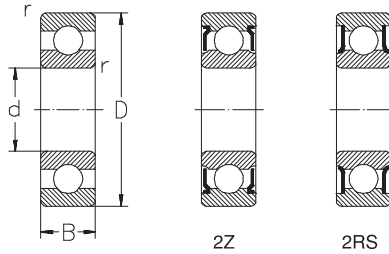

Dimensions				Basic radial load dyn. C _r	Designation stat. C _{0r}	opened	shielded	sealed
d	D	B	r min.					
mm					kN	-		
10	19	5	0,3	1720	840	S61800	S61800 ZZ	S61800 2RS
	22	6	0,3	2700	1270	S61900	S61900 ZZ	S61900 2RS
	26	8	0,3	4550	1980	S6000	S6000 ZZ	S600 2RS
	30	9	0,6	5100	2380	S6200	S6200 ZZ	S6200 2RS
	35	11	0,6	8100	3480	S6300	S6300 ZZ	S6300 2RS
12	21	5	0,3	1920	1040	S61801	S61801 ZZ	S61801 2RS
	24	6	0,3	2890	1460	S61901	S61901 ZZ	S61901 2RS
	28	8	0,3	5100	2380	S6001	S6001 ZZ	S6001 2RS
	32	10	0,6	6820	3050	S6201	S6201 ZZ	S6201 2RS
	37	12	1	9720	5080	S6301	S6301 ZZ	S6301 2RS
15	24	5	0,3	2070	1260	S61802	S61802 ZZ	S61802 2RS
	28	7	0,3	4350	2260	S61902	S61902 ZZ	S61902 2RS
	32	9	0,3	5580	2850	S6002	S6002 ZZ	S6002 2RS
	35	11	0,6	7650	3720	S6202	S6202 ZZ	S6202 2RS
	42	13	1	11500	5420	S6302	S6302 ZZ	S6302 2RS
17	26	5	0,3	2630	1570	S61803	S61803 ZZ	S61803 2RS
	30	7	0,3	4600	2550	S61903	S61903 ZZ	S61903 2RS
	35	10	0,3	6000	3250	S6003	S6003 ZZ	S6003 2RS
	40	12	0,6	9580	4780	S6203	S6203 ZZ	S6203 2RS
	47	14	1	13500	6580	S6303	S6303 ZZ	S6303 2RS
20	32	7	0,3	4000	2470	S61804	S61804 ZZ	S61804 2RS
	37	9	0,3	6400	3700	S61904	S61904 ZZ	S61904 2RS
	42	12	0,6	9380	5020	S6004	S6004 ZZ	S6004 2RS
	47	14	1	12800	6650	S6204	S6204 ZZ	S6204 2RS
	52	15	1,1	15800	7880	S6304	S6304 ZZ	S6304 2RS
22	44	12	0,6	9400	5050	S60/22	S60/22 ZZ	S60/22 2RS
	50	14	1	12900	6800	S62/22	S62/22 ZZ	S62/22 2RS
	56	16	1,1	18400	9250	S63/22	S63/22 ZZ	S63/22 2RS
25	37	7	0,3	4300	2950	S61805	S61805 ZZ	S61805 2RS
	42	9	0,3	7050	4550	S61905	S61905 ZZ	S61905 2RS
	47	12	0,6	10000	5850	S6005	S6005 ZZ	S6005 2RS
	52	15	1	14000	7880	S6205	S6205 ZZ	S6205 2RS
	62	17	1,1	22200	11500	S6305	S6305 ZZ	S6305 2RS

Stainless steel deep groove ball bearings

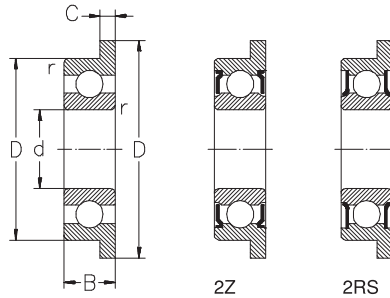

Dimensions						Basic radial load		Designation		
d	D	D ₁	B	C ₁	r min.	dyn. C _r	stat. C _{0r}	opened	shielded	sealed
mm						kN		-		
3	8	9,5	4	0,9	0,15	560	179	SF619/3	SF619/3 ZZ	
	10	11,5	4	1	0,15	630	218	SF623	SF623 ZZ	
	13	15	5	1	0,2	1300	485	SF633	SF633 ZZ	
4	11	12,5	4	1	0,15	960	345	SF619/4	SF619/4 ZZ	
	12	13,5	4	1	0,2	960	345	SF604	SF604 ZZ	
	13	15	5	1	0,2	1300	485	SF624	SF624 ZZ	
	16	18	5	1	0,3	1730	670	SF634	SF634 ZZ	
5	13	15	4	1	0,2	1080	430	SF619/5	SF 619/5 ZZ	
	14	16	5	1	0,2	1330	505	SF605	SF605 ZZ	
	16	18	5	1	0,3	1730	670	SF625	SF625 ZZ	SF625 2RS
	19	22	6	1,5	0,3	2340	885	SF635	SF635 ZZ	SF 635 2RS
6	15	17	5	1,2	0,2	1730	670	SF619/6	SF619/6 ZZ	SF619/6 2RS
	17	19	6	1,2	0,3	2260	835	SF606	SF606 ZZ	SF606 2RS
	19	22	6	1,5	0,3	2340	885	SF626	SF626 ZZ	SF626 2RS
	22	25	7	1,5	0,3	3300	1370	SF636	SF636 ZZ	SF636 2RS
7	17	19	5	1,2	0,3	1610	710	SF619/7	SF619/7 ZZ	SF619/7 2RS
	19	22	6	1,5	0,3	2340	885	SF607	SF607 ZZ	SF607 2RS
	22	25	7	1,5	0,3	3300	1370	SF627	SF627 ZZ	SF627 2RS
	26	29	9	2	0,3	4050	1620	SF637	SF637 ZZ	SF637 2RS
8	19	22	6	1,5	0,3	2240	910	SF619/8	SF619/8 ZZ	SF619/8 2RS
	22	25	7	1,5	0,3	3300	1370	SF608	SF608 ZZ	SF608 2RS
	24	26	8	2	0,3	3350	1430	SF628	SF628 ZZ	SF628 2RS
	28	30,25	9	2,25	0,3	4550	1970	SF638	SF638 ZZ	SF638 2RS
9	20	23	6	1,5	0,3	1720	840	SF619/9	SF619/9 ZZ	SF619/9 2RS
	24	27	7	1,5	0,3	3350	1430	SF609	SF609 ZZ	SF609 2RS
	26	28	8	2	0,3	4550	1970	SF629	SF629 ZZ	SF629 2RS
	30	32,5	10	2,5	0,6	5100	2390	SF639	SF639 ZZ	SF639 2RS
10	22	25	6	1,5	0,3	2700	1270	SF61900	SF61900 ZZ	SF61900 2RS
	26	28	8	2	0,3	4550	1980	SF6000	SF6000 ZZ	SF6000 2RS
	30	32,25	9	2,25	0,6	5100	2380	SF6200	SF6200 ZZ	SF6200 2RS
	35	37,75	11	2,75	0,6	8100	3480	SF6300	SF6300 ZZ	SF6300 2RS