

For New Technology Network











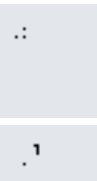
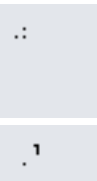



NTN[®]

NTNcorporation

Needle Roller Bearings



CAT. NO. 2300-VI/E

	Technical Data	A- 1~ 58
	Needle roller and cage assemblies	B- 3~ 20
	Needle roller and cage assemblies for connecting rod bearings	B- 21~ 28
	Drawn cup needle roller bearings	B- 29~ 52
	Machined-ring needle roller bearings	B- 53~ 96
	Machined-ring needle roller bearings, separable	B- 97~114
	Inner rings	B-115~132
	Clearance-adjustable needle roller bearings	B-133~138
	Complex bearings	B-139~160
	Roller followers	B-161~173
	Cam followers	B-174~204
	Thrust roller bearings	B-205~220
	Components Needle rollers / Snap rings / Seals	B-221~234
	Linear bearings	B-235~254
	One-way clutches	B-255~259
	Bottom roller bearings for textile machinery Tension pulleys for textile machinery	B-260~266
Appendixes		C- 1~ 20

Warranty

NTN warrants, to the original purchaser only, that the delivered product which is the subject of this sale (a) will conform to drawings and specifications mutually established in writing as applicable to the contract, and (b) be free from defects in material or fabrication. The duration of this warranty is one year from date of delivery. If the buyer discovers within this period a failure of the product to conform to drawings or specifications, or a defect in material or fabrication, it must promptly notify NTN in writing. In no event shall such notification be received by NTN later than 13 months from the date of delivery. Within a reasonable time after such notification, NTN will, at its option, (a) correct any failure of the product to conform to drawings, specifications or any defect in material or workmanship, with either replacement or repair of the product, or (b) refund, in part or in whole, the purchase price. Such replacement and repair, excluding charges for labor, is at NTN's expense. All warranty service will be performed at service centers designated by NTN. These remedies are the purchaser's exclusive remedies for breach of warranty.

NTN does not warrant (a) any product, components or parts not manufactured by NTN, (b) defects caused by failure to provide a suitable installation environment for the product, (c) damage caused by use of the product for purposes other than those for which it was designed, (d) damage caused by disasters such as fire, flood, wind, and lightning, (e) damage caused by unauthorized attachments or modification, (f) damage during shipment, or (g) any other abuse or misuse by the purchaser.

THE FOREGOING WARRANTIES ARE IN LIEU OF ALL OTHER WARRANTIES, EXPRESS OR IMPLIED, INCLUDING BUT NOT LIMITED TO THE IMPLIED WARRANTIES OF MERCHANTABILITY AND FITNESS FOR A PARTICULAR PURPOSE.

In no case shall NTN be liable for any special, incidental, or consequential damages based upon breach of warranty, breach of contract, negligence, strict tort, or any other legal theory, and in no case shall total liability of NTN exceed the purchase price of the part upon which such liability is based. Such damages include, but are not limited to, loss of profits, loss of savings or revenue, loss of use of the product or any associated equipment, cost of capital, cost of any substitute equipment, facilities or services, downtime, the claims of third parties including customers, and injury to property. Some states do not allow limits on warranties, or on remedies for breach in certain transactions. In such states, the limits in this paragraph and in paragraph (2) shall apply to the extent allowable under case law and statutes in such states.

Any action for breach of warranty or any other legal theory must be commenced within 15 months following delivery of the goods.

Unless modified in a writing signed by both parties, this agreement is understood to be the complete and exclusive agreement between the parties, superceding all prior agreements, oral or written, and all other communications between the parties relating to the subject matter of this agreement. No employee of NTN or any other party is authorized to make any warranty in addition to those made in this agreement.

This agreement allocates the risks of product failure between NTN and the purchaser. This allocation is recognized by both parties and is reflected in the price of the goods. The purchaser acknowledges that it has read this agreement, understands it, and is bound by its terms.

© NTN Corporation. 2002

Although care has been taken to assure the accuracy of the data compiled in this catalog, NTN does not assume any liability to any company or person for errors or omissions.

NTN

Needle Roller Bearings

TECHNICAL DATA CONTENTS

1. Classification and Characteristics of Bearings	A- 4
2. Load Rating and Life	A-14
2. 1 Bearing life	A-14
2. 2 Basic rated life and basic dynamic load rating	A-14
2. 3 Bearing-applied machine and requisite life of bearing	A-14
2. 4 Bearing life using adjusted life rating factors	A-15
2.4.1 Reliability adjustment factor α_1	A-15
2.4.2 Bearing characteristic adjustment factor α_2	A-15
2.4.3 Operating condition adjustment factor α_3	A-16
2. 5 Affect on basic dynamic load rating by the hardness of raceway	A-16
2. 6 Life of bearing with oscillating motion	A-16
2. 7 Life of bearing with linear motion	A-17
2. 8 Various factors influencing bearing life	A-17
2. 9 Mounting deviation and crowning	A-18
2.10 Relation of bearing life to radial internal clearance, surface roughness and surface hardness	A-19
2.11 Basic static load rating	A-19
2.12 Allowable static bearing load	A-19
3. Calculation of Bearing Loads	A-20
3.1 Loads acting on shafting	A-20
3.1.1 Loads acting on gears	A-20
3.1.2 Loads acting on chain and belt shafts	A-22
3.1.3 Load factor	A-22
3.2 Load distribution to bearing	A-23
3.3 Mean load	A-25
4. Bearing Accuracy	A-25
5. Bearing Clearance	A-30
5.1 Radial clearance in bearing	A-30
5.2 Running clearance	A-30
5.2.1 Setting up running clearance	A-30
5.2.2 Calculation of running clearance	A-30
5.3 Bearing fit and bearing radial clearance	A-31
6. Bearing Fits	A-32
6.1 Clamping allowance	A-32
6.2 Necessity of proper fit	A-32
6.3 Fit selection	A-32
6.4 Recommended fits	A-33
6.5 Calculation of clamping allowance	A-35
7. Shaft and Housing Design	A-36
7.1 Design of bearing mount	A-36
7.2 Bearing fitting dimensions	A-38
7.3 Shaft and housing accuracy	A-39
7.4 Raceway surface accuracy	A-39
7.5 Raceway material and its hardness	A-39
7.6 Allowable bearing misalignment	A-39
8. Lubrication	A-40
8.1 Grease lubrication	A-40
8.1.1 Types and properties of grease	A-40
8.1.2 Base oil	A-40
8.1.3 Thickening agent	A-40
8.1.4 Additives	A-41
8.1.5 Consistency	A-41
8.1.6 Grease mixing	A-41
8.1.7 Grease fill amount	A-41
8.1.8 Grease replenishing	A-42
8.2 Oil lubrication	A-42
8.2.1 Lubrication method	A-42
8.2.2 Lubrication oils	A-43
8.2.3 Oiling rate	A-44
8.2.4 Lubrication oil replacement cycle	A-44
9. Seals	A-45
9.1 Non-contact seal, contact seal	A-45
9.2 Duplex seal	A-47
9.3 Clearance setting	A-47
9.4 NTN seals	A-47
9.5 Seal materials and operating temperature	A-47
9.6 Seal type and allowable speed	A-47
9.7 Shaft surface hardness	A-48
10. Bearing Handling	A-49
10.1 Bearing storage	A-49
10.2 Bearing installation	A-49
10.3 Post-installation running test	A-50
10.4 Bearing disassembly	A-50
10.5 Required press-fit and pull-out forces	A-51
10.6 Washing	A-51
11. Technical Data	A-52
11.1 HL bearing	A-52
11.1.1 Basic concept of HL bearing	A-52
11.1.2 HL surface	A-52
11.1.3 Application examples	A-52
11.2 Bearings with solid grease	A-53
11.2.1 Features of bearings with solid grease	A-53
11.2.2 Precautions in use of bearings with solid grease	A-53
11.2.3 Application examples of bearings with solid grease	A-53
11.3 Calculation examples	A-54
11.3.1 Shrinkage of drawn-cup needle roller bearing and post-installation clearance	A-54
11.3.2 Track load capacity of cam follower/roller follower	A-55
11.3.3 Outer ring strength	A-56
11.3.4 Stud strength of cam follower	A-56
12. Bearing Type Codes and Auxiliary Codes	A-57

DIMENSIONAL DATA CONTENTS

Needle Roller and Cage Assemblies	B- 3	Cam Followers	B-174
K, K·T2, K·S, K·ZW, KMJ, KMJ·S, KJ·S, KV·S	B- 6	KR, KR·LL, KRV, KRV·LL	B-182
PCJ	B-18	KRT, KRT·X, KRT·LL, KRT·XLL	B-186
Needle Roller and Cage Assemblies for Connecting Rod	B-21	KRVT, KRVT·X, KRVT·LL, KRVT·XLL	B-188
PK,KBK	B-25	KRU, KRU·LL, KRVU, KRVU·LL	B-190
Drawn Cup Needle Roller Bearings	B-29	NUKR	B-194
HK, HK·ZWD, HMK, HMK·ZWD, BK, BK·ZWD	B-36	NUKRT, NUKRT·X	B-196
HK·L, HMK·L, HK·LL, HMK·LL, BK·L	B-44	NUKRU, NUKRU·X	B-198
DCL	B-48	CR, CR·LL	B-200
HCK	B-52	CRV·X, CRV·XLL	B-202
Machined-Ring Needle Roller Bearings	B-53	Thrust Roller Bearings	B-205
RNA48, RNA49, RNA59, RNA69, NK	B-58	AXK11, AS11, WS811, GS811	B-210
NA48, NA49, NA59, NA69, NK+IR	B-66	811, 812, 893, K811, K812, K893, WS811, WS812, WS893, GS811, GS812, GS893	B-214
MR	B-80	Components / Needle rollers	B-221
MR+MI	B-86	A, F	B-224
RNA49·L, RNA49·LL	B-94	Components / Snap rings	B-226
NA49·L, NA49·LL	B-95	WR	B-227
Machine-ring Needle Roller Bearings, Separable Type	B-97	BR	B-229
RNAO, RNAO·ZW	B-100	Components / Seals	B-232
NAO, NAO·ZW	B-108	G, GD	B-233
Inner ring	B-115	Machined-Ring and Drawn-cup Linear Ball Bearings	B-235
IR	B-117	KLM, KLM·LL, KLM·S, KLM·SLL, KLM·P, KLM·PLL	B-241
MI	B-129	KH, KH·LL	B-243
Clearance-Adjustable Needle Roller Bearings	B-133	Stroking Linear Ball Bearings	B-244
RNA49·S	B-136	KD, KD·LL	B-246
NA49·S	B-137	Linear Flat Roller Bearings	B-248
Complex Bearings	B-139	FF, FF·ZW	B-250
NKX, NKX·Z	B-144	BF, RF	B-251
NKX+IR, NKX·Z+IR	B-146	Linear Roller Bearings	B-252
NKXR, NKXR·Z	B-148	RLM	B-253
NKXR+IR, NKXR·Z+IR	B-150	One-way Clutches	B-255
NKIA	B-152	HF	B-258
NKIB	B-154	HFL	B-259
AXN	B-156	Bottom Roller Bearings for Textile Machinery	B-260
ARN	B-158	FRIS (Series A)	B-261
Roller Followers	B-161	FRIS (Series B)	B-263
NA22·LL, RNA22·LL	B-166	FR	B-264
NATR, NATR·LL, NATV, NATV·LL	B-168	Tension Pulleys for Textile Machinery	B-265
NACV·X, NACV·XLL	B-170	JPU·S, JPU·S+JF·S	B-266
NUTR	B-172	Appendix	C- 1
NUTW	B-173		

1. Classification and Characteristics Bearings

Needle roller bearings have relatively smaller diameter cylindrical rolling elements whose length is much larger than their diameter.

Compared with other types of rolling bearings, needle roller bearings have a small cross-sectional height and significant load-bearing capacity and rigidity relative to

their volume. Also, because the inertial force action on them is limited, they are ideal choice for oscillating motion. Needle roller bearings contribute to compact and lightweight machine designs. They serve also as a ready replacement for sliding bearings.

NTN offers the following types of needle roller bearings.

Needle roller and cage assembly

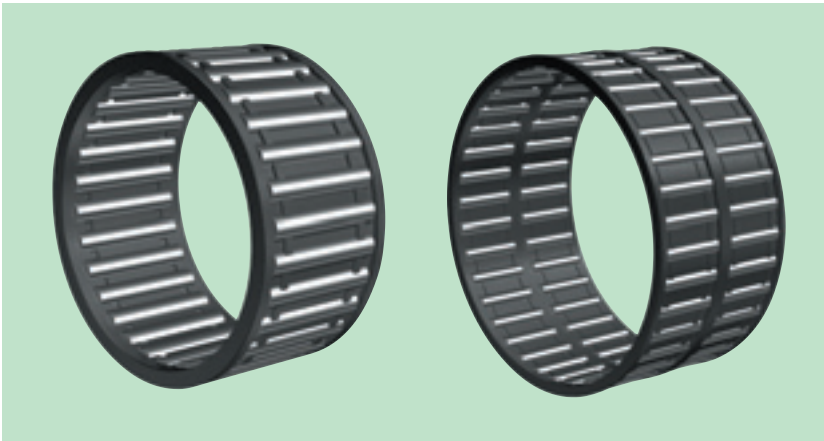

This assembly, a major component of a needle roller bearing, comprises needle rollers and a cage to support the rollers.

- Using the shaft and housing as raceway surfaces reduces the cross-sectional height: it is equal to the diameter of the needle roller bearing.
- This structure eliminating the outer and inner rings allows the bearing to be fitted more easily.
- The assembly is available in both single-row and double-row configurations.
- As long as the tolerance limit of the shaft and housing is satisfied, the radial internal clearance can be made adjustable.

Needle roller and cage assembly for connecting rods

This assembly, a major component of a needle roller bearing, comprising needle rollers and a cage to support the rollers, is used typically for connecting rods in reciprocating compressors and small- and mid-sized internal combustion engines such as those for motorbikes, light cars, outboard motors and versatile engines. This assembly features such a cage that is specifically optimized for severe operating conditions involving high impact loads, complicated motions, high-speed revolution and/or high operating temperatures.

Needle roller and cage assembly for large end



- This assembly, subjected to a cranking motion with a simultaneous action of the rolling elements' rotation and revolution, must be light but have a high rigidity, and must have a precise dimension of the outer diameter of the cage so that the guiding system can keep an appropriate gap.
- The cage is made of high-tensile special steel with a surface hardening treatment.
- The guiding system employed is an outer diameter guiding system.
- The cage that may be subjected to poor lubrication can be protected with a surface treatment using a non-ferrous metal.
- For applications with a one-piece structure of crank shaft, the cage of split type is also available.

Needle roller and cage assembly for small end

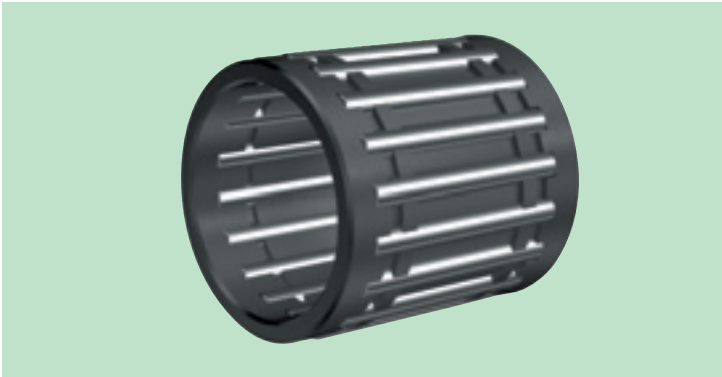

- Strong impact load acts on this bearing and it oscillates at high speed. Therefore, the cage bore surface is finished with high precision so as to secure lightweight, high rigidity and proper guide clearance.
- The cage is made of high tensile special steel and its surface is hardened ideally.
- The cage is of bore guide type and the guide surface is designed as long as possible to thereby reduce the surface pressure.
- The roller length is designed to the possible maximum value against the connecting width and a number of small-size needle rollers are fitted in the cage to minimize the contact pressure.

Drawn-cup needle roller bearing

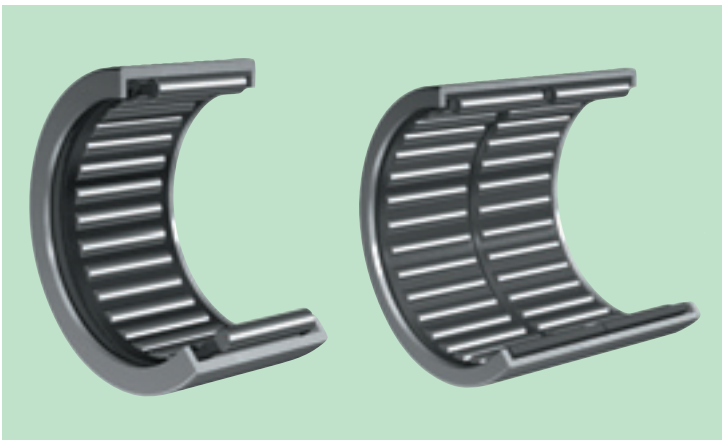

This bearing comprises an outer ring and needle rollers, which were both drawn from special thin steel plate by precision deep drawing, and a cage intended to guide precisely the needle rollers.

- This bearing is the type of the lowest section height, of the rolling bearings with outer ring, best-suited to space-saving design.
- A hardened and ground shaft or inner ring (IR Series) is used as the raceway.
- This bearing needs no axial locking due to easy installation and press-fit in the housing.
- The close end type to close shaft end is available in addition to the open end type.
- Furthermore, the type with seal fitted in at single side or double sides is also available.
- The standard type comprises a needle roller and cage assembly. In addition to this type, special type comprising full complement rollers is available at option.

Machined-ring needle roller bearings



This bearing type comprises a machined outer ring and machined needle rollers, and a cage to guide properly the needle rollers.

In the case of this bearing, the cage or the needle rollers are guided by the ribs of the outer ring or the face ring. Hence, this bearing is non-separable type. In addition, the type with no inner ring is also available for enabling a shaft to be used as the raceway surface. (Of course, the type with inner ring is available.)

- Selectively available for both of the metric system and the inch system.
- Best-suited to space-saving design due to its low section height, then having the large load capacity.
- High rigidity and high bearing accuracy due to its machined (precut) outer ring
- can be used with a housing made of light metal, etc. due to its outer ring of high rigidity.
- Outer ring with lubrication hole and lubrication groove
- Single row and double row types available.
- The type with seal fitted in at single side or double sides is also available.

Machined-ring needle roller bearing separable type

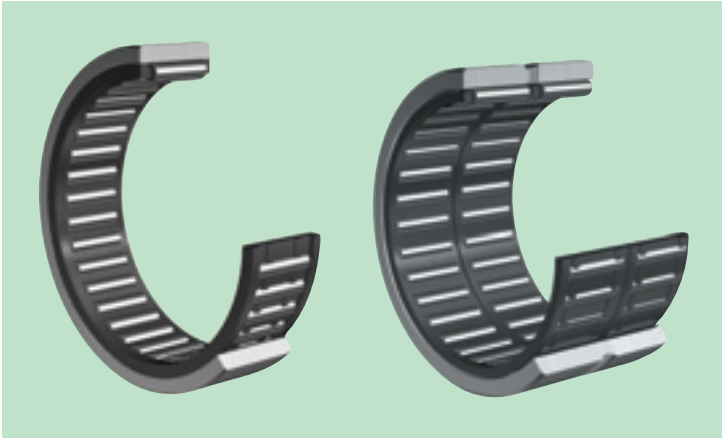

This bearing type comprises a machined outer ring and machined needle rollers, and a cage to guide and retain properly the needle rollers. And the needle roller and cage assembly is separable from the outer ring. In addition to the standard type, the type with no inner ring is also available for enabling a shaft to be used as direct raceway surface. (Of course, the type with inner ring available, too.)

- Easy to install, — the needle roller and cage assembly, the outer ring, and the inner ring can be mounted independently from each other.
- Any optional radial internal clearance is selectable by combining the individual independent components.
- Best-suited to space-saving design due to its low section height, then having the large load capacity.
- High rigidity and high bearing accuracy due to its machined (precut) outer ring.
- Can be used with a housing made of light metal, etc. due to its outer ring of high rigidity.
- Single row and double row types available. And the outer ring of the double row bearing is provided with lubrication hole and lubrication groove.

Inner ring

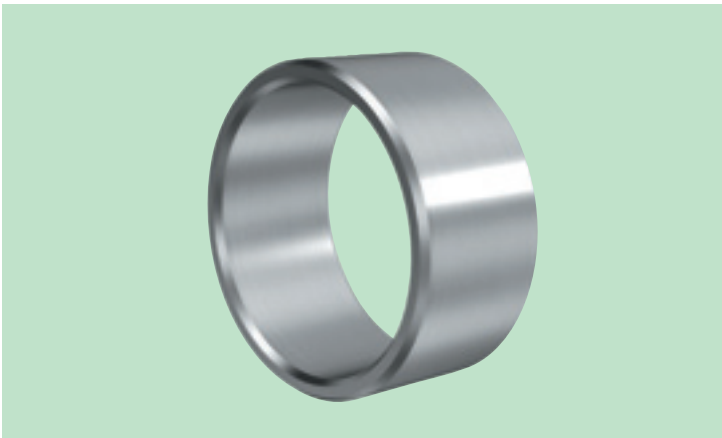

For the needle roller bearings, usually a shaft is used as the raceway surface, but this inner ring is used where the shaft surface can not be machined to the specific hardness and roughness. This inner ring is suited to space-saving design due to its low section height. This is made of high carbon chrome bearing steel, finished by high precision grinding after heat-treated.

- Can also be used as a bush.
- Selectively available for both of the metric system and the inch system.
- The type with lubrication hole at the raceway center also available.

Clearance-adjustable needle roller bearing



This bearing type comprises a machined outer ring and machined needle rollers, and a cage to guide and retain properly the needle rollers, but the needle roller and cage assembly is non-separable from the outer ring. In addition to the standard type, the type with no inner ring is also available for enabling a shaft to be used as direct raceway surface. (Of course, the type with inner ring available, too.)

- The raceway diameter of the outer ring is shrunk by pressing the outer ring in axial direction, which then enables to reduce the roller set bore diameter correspondingly.
- Radial clearance is finely adjustable by adjusting axial pressing load and thereby changing shrinkage of the outer ring raceway diameter.
- This bearing is applied to the work spindle of a machine tool and other similar portions which require the high speed rotational accuracy of JIS Grade-4.

Thrust roller bearing

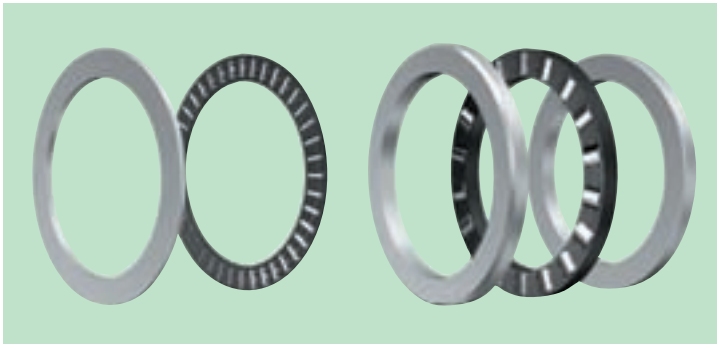

This bearing comprises needle rollers or cylindrical rollers, a cage to guide and retain properly the rollers, and disc-shaped rolling bearing ring. This is a bearing capable of supporting one-way axial load. Furthermore, this bearing can be used without rolling bearing ring, where the heat-treated and ground bearing mount surface can be used as the raceway surface.

- Best-suited to space-saving design due to its small section height, then having the large load capacity.
- Available are AS type rolling bearing ring made of thin steel plate with hardened surface and WS type and GS type machined rings.

Complex needle roller bearings — Needle roller bearing with thrust bearing —



This complex bearing comprises a radial needle roller bearing for supporting radial load and a thrust bearing for supporting axial load which are assembled integrally. Both thrust ball bearing type and thrust axial roller bearing type are available as the bearing intended to support axial load.

- The thrust bearing with dust-proof cover is also available, which has a good effect in preventing scattering of oil and grease and invasion of external dust, etc.

Complex needle roller bearings

— Needle roller bearing with angular ball bearing, needle roller bearing with three-point contact ball bearing —



This complex bearing comprises a radial needle roller bearing for supporting radial load, a ball bearing for supporting comparatively small axial load and a machined inner ring which are all assembled integrally. Both angular ball bearing and three-point contact ball bearing are available as the ball bearing intended to support axial load.

- The complex needle roller bearings (NKIA Series) using an angular ball bearing as the thrust bearing can support one-directional angular load.
- The complex needle roller bearings (NKIB Series) using a three-point contact ball bearing as the thrust bearing can support double-directional axial load and furthermore its position in axial direction can be fixed, too.

Needle roller bearing with double thrust roller bearing

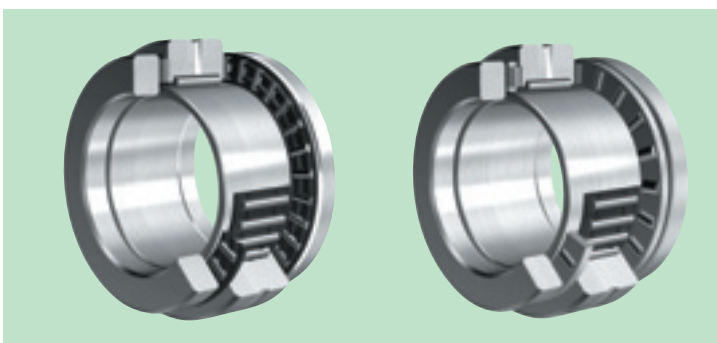

This is a complex bearing wherein a thrust needle roller bearing or a thrust cylindrical roller bearing intended to support axial load is configured at the double sides of a radial needle roller bearing for supporting radial load.

- Can support large axial load acting thereon from the double sides.
- Used as the bearing (precision bearing) for supporting the ball screw of a machine tool.

The track roller bearing is a needle roller bearing with thick outer ring, which is applied to cam roller, guide roller, eccentric roller and rocker arm.

The track roller bearings are mainly categorized into a yoke type track roller bearing (roller follower) and a stud type track roller bearing (cam follower). Various types of the roller follower and the cam follower are available as described hereunder.

Roller follower — Without axial guide —

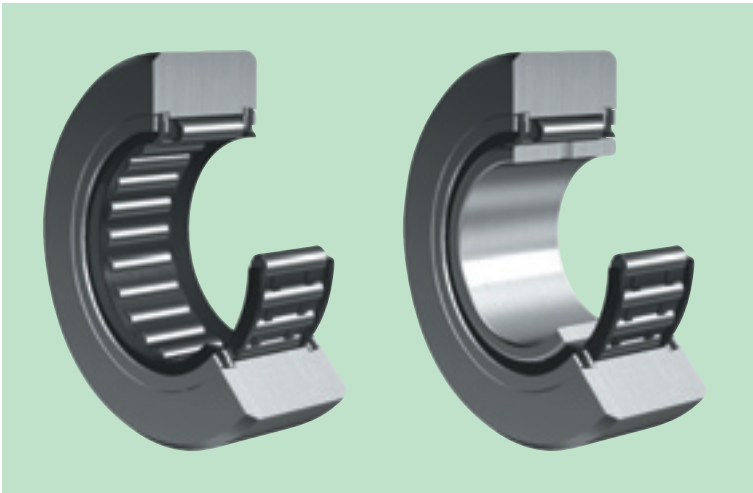

This roller follower is a bearing designed for rotation of the outer ring wherein a needle roller and cage assembly and a synthetic rubber seal reinforced with steel plate are assembled in the thick-walled outer ring.

- The outer ring, the needle roller and cage assembly, and the rubber seal are non-separable from each other.
- The outer ring is thick-walled type so that it is resistible to high load and impact load.
- The shaft must be provided with a thrust washer and a flange, because of the outer ring with no ribs (or face ring) and no axial guide function.
- The outer surface is available in both spherical (crowning) profile and cylindrical profile.
- The bearing with spherical outer ring is effective in damping bias load which is caused by deviation in installing.
- The bearing with cylindrical outer ring is suitable to the cases of large load and low-hardness track surface, due to its large area of contact with the mating track surface.

Roller follower — With axial guide —

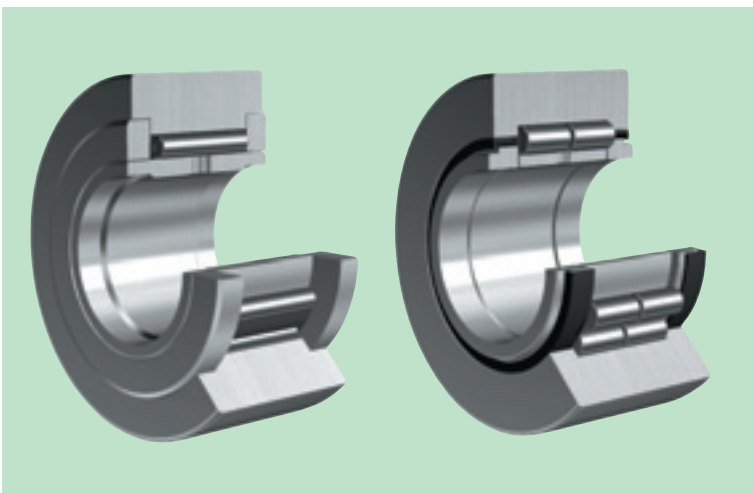

This roller follower is a bearing designed for rotation of the outer ring wherein a needle roller and cage assembly, an inner ring, and a face ring are assembled in the thick-walled outer ring.

This bearing uses needle rollers as its rolling element and furthermore classified into bearing with cage and full complement roller bearing without cage. The outer ring is guided axially by a face ring which is press-fitted in the inner ring.

- The outer ring is thick-walled type so that it is resistible to high load and impact load.
- The outer surface is available in both spherical (crowning) profile and cylindrical profile.
- The bearing with spherical outer ring is effective in damping bias load which is caused by deviation in installing.
- The bearing with cylindrical outer ring is suitable to the cases of large load and low-hardness track surface, due to its large area of contact with the mating track surface.
- This bearing is easier to handle because it needs no mounting of a guide (thrust washer, etc.) on the shaft unlike other types without axial guide (RNA22, NA22).

Cam follower — Needle roller type —

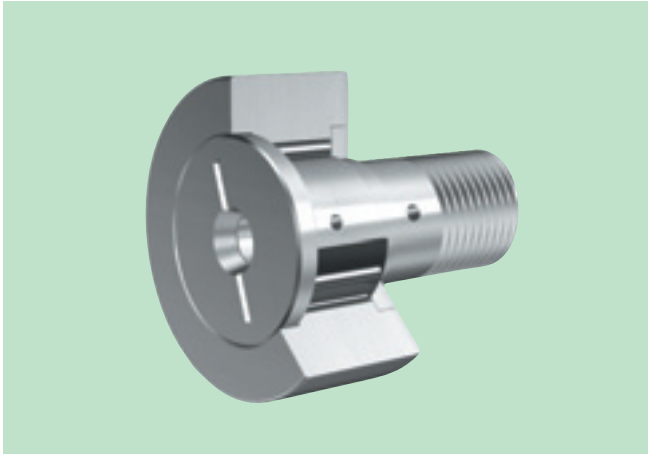

This is a bearing designed for rotation of the outer ring in which a needle roller and cage assembly and a stud in lieu of inner ring are fitted in the thick-walled outer ring. The stud is so threaded as to be mounted easily. This cam follower (bearing) uses needle rollers as its rolling element and it is further classified into one bearing type with cage and another full complement roller bearing type without cage.

- The bearing type with cage is suitable to comparatively high speed running because its rollers are guided by the cage.
- The full complement roller type enabling to use more needle rollers than the type with cage has large load capacity.
- The outer surface is available in both spherical (crowning) profile and cylindrical profile.
- This cam follower (bearing) is selectively available for both of the metric system and the inch system.
- Furthermore, the seal built-in type is also available.
- The stud is of either recessed head type allowing use of a screwdriver or hexagon socket head type so as to be mounted and adjusted easily.

Cam follower — Cylindrical roller type —

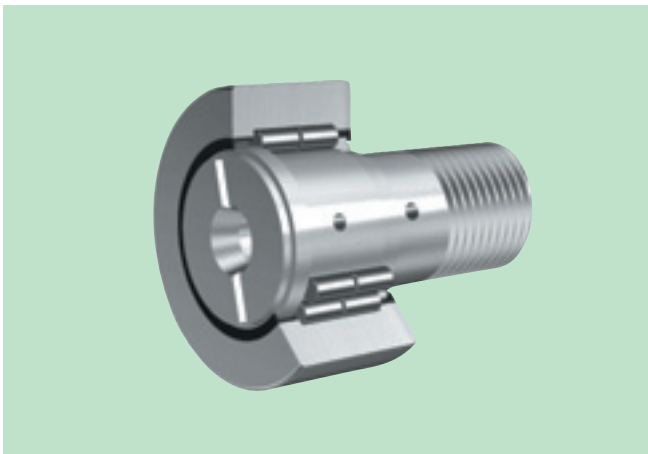

This is a full complement roller bearing designed for rotation of the outer ring in which double-row cylindrical rollers and a stud in lieu of inner ring are fitted in the thick-walled outer ring. The stud is so threaded as to be mounted easily.

- This cam follower (bearing) has the radial /axial load capacity larger than the needle roller type.
- A steel plate is press-fitted in the outer ring and a labyrinth seal is formed between the face ring and the outer ring.
- The outer surface is available in both spherical (crowning) profile and cylindrical profile.
- The stud is of either recessed head type allowing use of a screwdriver or of hexagon socket head type so as to be mounted and adjusted easily.

Cam follower — Eccentric type —



This is a cam follower (bearing) wherein the studs of the needle roller type and cylindrical roller type prescribed above were made eccentric, which can then be adjusted by making eccentric the outer ring relative position against the raceway.

- Load distribution is easily adjustable in configuring two or more cam followers in linear form.
- Preload can be applied by adjustment of load distribution.
- Alignment is possible even when the mounting hole is not processed in high accuracy.
- The outer surface is selectively available in both spherical (crowning) profile and cylindrical profile.
- The stud is of either recessed head type allowing use of a screwdriver or hexagon socket head type so as to be mounted and adjusted easily.

The components described hereunder are for needle roller bearing.

Needle rollers



The needle rollers with flat end face and round end face are standard. These rollers are made of high-carbon chrome bearing steel, surface-finished by grinding and buffing after heat-treated. The standard accuracy of these rollers is "Precision Grade".

- A-Inter-diameter tolerance of the needle rollers is 2mm maximum.
- The roller type with crowned rolling surface is also available, which can damp edge load.
- These needle rollers are supplied as an individual for applications (pin, shaft) other than rolling element.

Snap rings

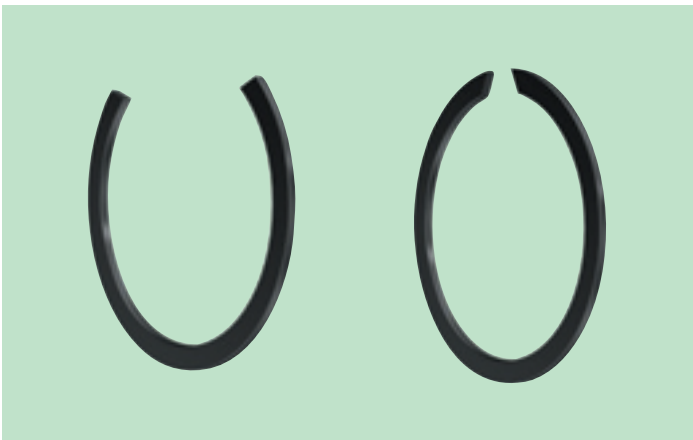

These are special-purposed rings used for axially positioning or guiding the inner and outer rings or the needle roller and cage assembly in needle roller bearing.

The ring material is a hard steel wire rod and chemical conversion treatment is applied to its surface so as to provide high rigidity.

- Two types are available for shaft and housing use.
- The section height is lowered flexibly according to the dimensions of needle roller bearings. In addition, manufacture of these rings is available up to the possible minimum dimensional range.
- For the axial guide it is recommended to provide a spacer between the cage and the snap ring.

Seals



This is a special-purposed seal which was designed so as to match the small section height of needle roller bearings.

- G-type seal with one lip and GD-type seal with two lips are selectively available on application.
- These seals comprising steel ring and synthetic rubber can be used at the operating temperature ranging from -25 to 120°C, but continuous use thereof is subject to 100°C and less.
- These seals act to prevent invasion of external foreign matter and over-consumption of lubrication grease.
- The radial section height of each seal is designed so as to match the drawn-cup needle roller bearings. Hence, these seals require no additional finishing of the housing. This facilitates handling.

This catalogue describes the following ones of linear motion bearings.

Linear ball bearing — Machined ring type —

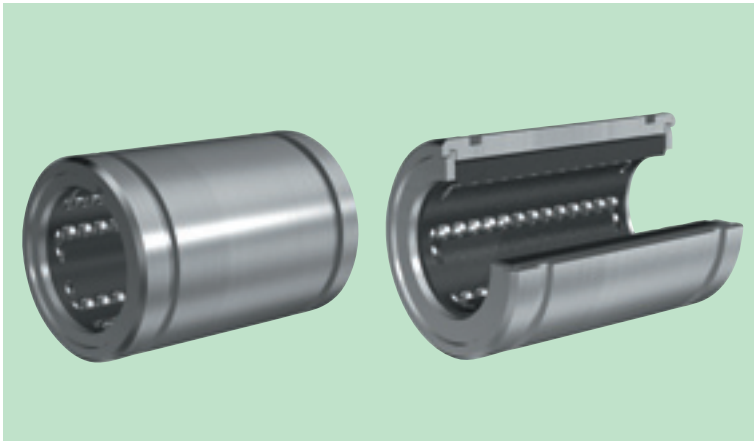

This is a high precision bearing which comprises a machined outer ring and face ring, steel balls and a synthetic resin cage for retaining the balls and rolls on a shaft, maintaining the endless linear motion.

- Standard type, clearance-adjustable type and open type are selectively available on application.
- Some bearings of these types are provided with a synthetic rubber seal at single side or double sides to prevent invasion of foreign matter therein.
- The steel balls are guided precisely by the cage so that stable linear motion can be achieved with less friction resistance.
- No rotational motion is available.

Linear ball bearing — Drawn cup type —

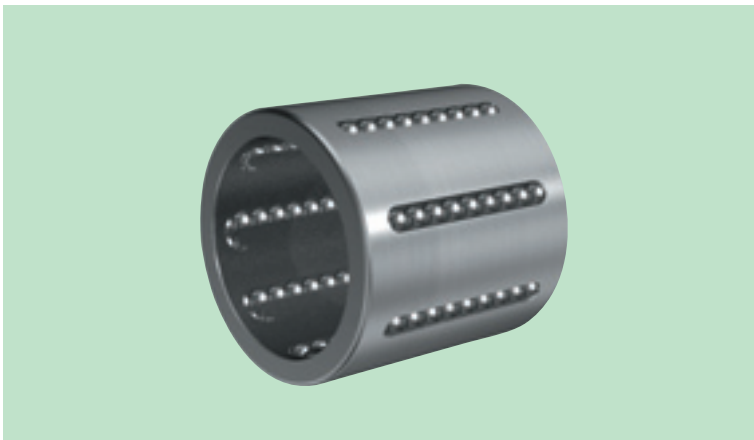

This is a high precision bearing which comprises an outer ring drawn from thin special steel plate by precision deep drawing, steel balls and a synthetic resin cage for retaining the balls and rolls on a shaft, maintaining the endless linear motion.

- The outer ring made of thin steel plate enables to make less the section height and to design the linear motion system of compact structure.
- Easy to install — This bearing is press-fitted in the housing so that it requires no axial fixing.
- No rotational motion available.
- Some bearings of this type are provided with a synthetic rubber seal at double sides to prevent invasion of foreign matter therein.

Linear ball bearing — Stroking type —

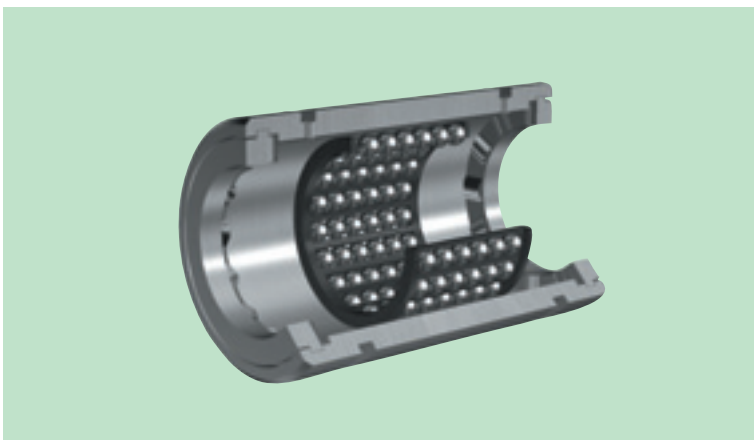

This bearing comprises a machined outer ring and face ring, steel balls and a cage for retaining the balls and reciprocates finitely on a shaft as well as rotates on a shaft. The outer ring is provided with a snap ring as the cage stopper at its double sides and, furthermore, a wavy spring is provided between the snap ring and the cage to damp impact acting the cage and to thereby prevent wear of the cage.

- Some bearings of this stroking type are provided with a synthetic rubber seal at its double sides to prevent invasion of foreign matter therein.
- The outer ring is so grooved that snap ring can be fitted and fixed easily.

Linear flat roller

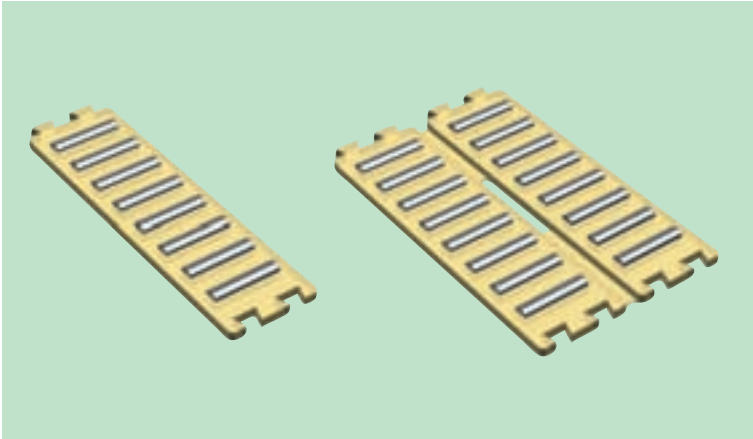

This is a flat roller bearing which comprises a flat cage and needle rollers and reciprocates on a flat raceway in linear direction by motion of its linear movable components.

- The molded polyamide resin cage and press-formed steel plate cage are selectively available on application.
- FF type molded resin cage — Several cages can be used with them jointed with each other in parallel configuration.
- The press-formed steel plate cage — Cage to cage jointing is unavailable, but it can be supplied at any optional length.
- In the case of double-row resin cage, it is provided with an elastic joint at its center part so it can be reformed at any optional angle by dipping it in an oil of 70 to 90°C and can be mounted on a Vee-grooved surface.

Linear roller bearing

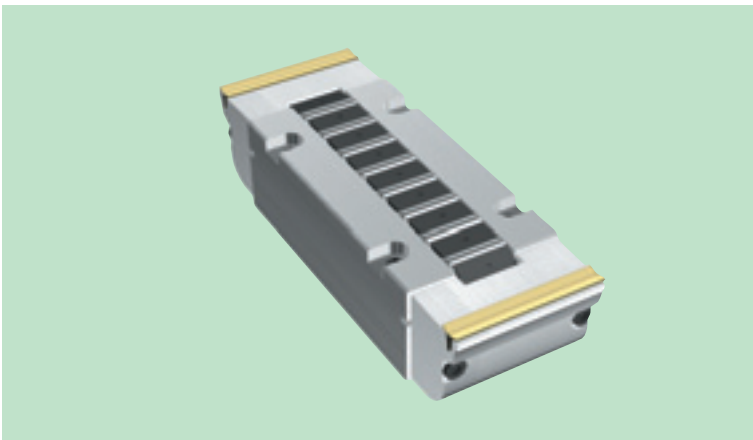

This bearing comprising cylindrical rollers capable of turning internally around the track frame moves endlessly on a flat surface in linear direction.

- Low friction factor due to the case assemblies preventing neighboring roller from touching.
- High load rating due to use of cylindrical rollers.

This catalogue describes the following products, too.

One-way clutch

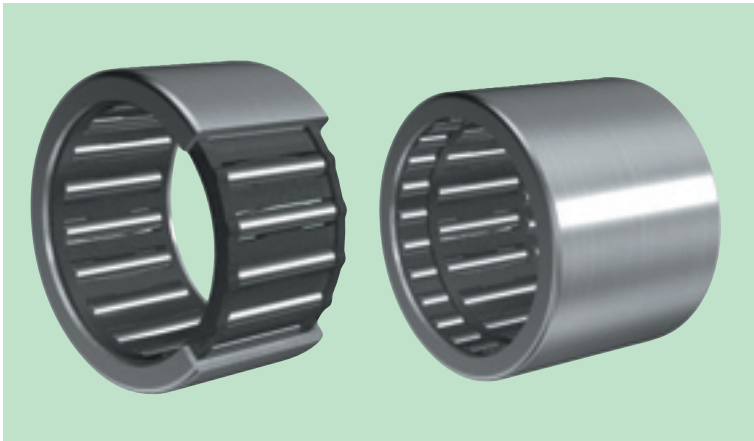

This one-way clutch comprises an outer ring drawn from thin special steel plate by precision deep drawing, spring, needle rollers and cage and can transmit a torque in only one way.

- Less friction torque against over-running, great transmission torque for small section height.
- Various types are available as follows; one-way clutch with bearing built therein to support radial load, one-way clutch with outer ring plated for improvement of erosion resistance, one-way clutch integrated with gear, pulley, etc.
- HF type and HFL type can be locked axially by being only press-fitted in the housing.
- These one-way clutches use the outer ring drawn by precision deep drawing, which needs the housing with wall thickness of a specified value or more.
- HF type is subjected to configuration of a radial ball bearing at its double ends. (On the other hand, HFL type is complete with radial bearings built-in at its double sides.)

Bottom roller bearing — For textile machinery —

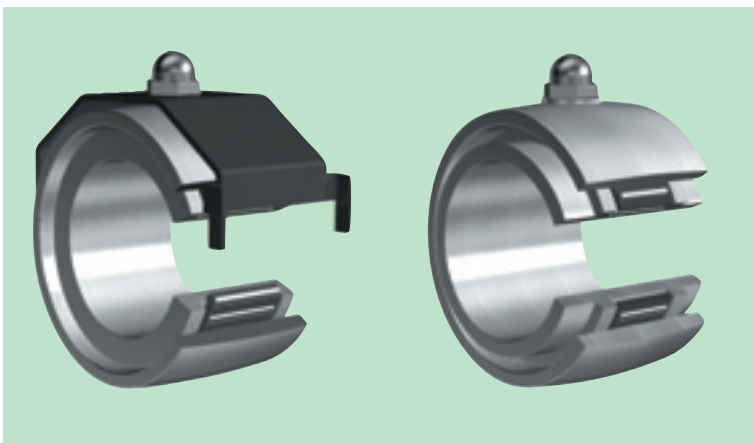

This is a grease pre-filled needle roller bearing intended to support the bottom rollers. The spherical outer surface of the outer ring can allow bottom roller mounting error to some extent. On the other hand, the inner ring is provided with ribs at its double ends. A clearance between the outer ring ribs and the inner ring ribs is kept less and, in addition, the outer surface of each inner ring rib is knurled so as not to allow easy invasion of mist, etc. into the bearing.

Tension Pulley — For Textile Machinery —



This pulley is used to guide the tapered portion or belt of the spindle drive unit in each of a fine spinning machine, a rough spinning machine, a pre-twisting machine, etc. as well as to apply tension to them. The pulley drawn from steel plate by precision deep drawing is press-fitted on the outer ring of shaft bearing instead of inner ring.

2. Load Rating and Life

2.1 Bearing life

Even when bearings are in running under normal condition, the raceway surface and the surfaces of the rolling elements inevitably subjected to repetitive compression stress result in flaking due to fatigue of the raceway an element materials and can resist no longer to further running even under normal condition. "Bearing life" is defined as the total cumulative bearing revolutions until flaking occurs thus on the raceway surface or the element rolling surfaces.

Further use of bearings becomes unavailable, caused by various defects such as seizure, wear, crack, chipping, chattering, rusting, etc. in addition to the flaking phenomenon stated above. However, these phenomena should be deemed as defects of bearing itself and, therefore, be discriminated from bearing life. And the defect causes are such as incorrect selection of bearing, improper mounting, improper lubrication, imperfect sealing, etc. Hence, bearing trouble can be avoided by removing the said causes.

2.2 Basic rated life and basic dynamic load rating

Even when a group of same bearings have been in running under the same condition, considerably great variation is found among the individual bearing lives. This comes from variation in material fatigue itself. Hence, the basic rated life defined below considering statistically this variation in material fatigue is applied as the bearing life.

The basic rated life means the substantial total cumulative revolutions of the individual bearings 90% (90% reliability) of which can revolve without resulting in flaking due to rolling fatigue when a group of same bearings have been put individually in continuous running under same condition. When bearings have been in running in constant revolution, the basic rated life is expressed as the total cumulative revolutions of the individual bearings.

On the other hand, the basic dynamic load rating represents the load capacity of rolling bearing, then meaning a constant load under which the basic rated life of 1,000,000 revolutions is achieved. This constant load of radial bearing is expressed with net radial load, while that of thrust bearing is expressed with net axial load.

The bearing dimensions table in this catalogue describes the respective basic dynamic load ratings of the bearings that were manufactured using NTN's standard materials and manufacturing processes in current use.

For the respective basic rated lives of the bearings manufactured using the special materials and special manufacturing processes, feel free to contact NTN for inquiry.

The relationship among the basic rated life, the basic dynamic load rating and the axial load can be expressed in **formula (2.1)**.

Basic Rated Life specified in ISO 281.

$$L_{10} = \left(\frac{C}{P} \right)^p \dots\dots\dots(2.1)$$

where,

$p = 10/3$ For roller bearing
 $p = 3$ For ball bearings

L_{10} : Basic rated life (10^6 revolutions)
 C : Basic dynamic rated load, (N) (kgf)
 (radial bearings: C_r , thrust bearings: C_a)
 P : Bearing load, (N) (kgf)
 (radial bearings: P_r , thrust bearings: P_a)

Furthermore, the basic rated life can be determined by **formula (2.2)**, where it is expressed in the operating hours.

$$L_{10h} = 500 f_n^p \dots\dots\dots(2.2)$$

$$f_n = f_n \frac{C}{P} \dots\dots\dots(2.3)$$

$$f_n = \left(\frac{33.3}{n} \right)^{1/p} \dots\dots\dots(2.4)$$

where,

L_{10h} : Basic rated life, h
 f_n : Life factor
 f_n : Speed factor
 n : Rotational speed, r/min

The **formula (2.2)** can also expressed as **formula (2.5)**.

$$L_{10h} = \frac{10^6}{60n} \left(\frac{C}{P} \right)^p \dots\dots\dots(2.5)$$

Considering the life of either one, of several bearings installed in a machine or an equipment, until it breaks down due to rolling fatigue as the total bearing life as a whole, it can be determined by **formula (2.6)**.

$$L = \frac{1}{\left(\frac{1}{L_1^e} + \frac{1}{L_2^e} + \dots + \frac{1}{L_n^e} \right)^{1/e}} \dots\dots\dots(2.6)$$

where,

$e = 9/8$ For roller bearings
 $e = 10/9$ For ball bearings
 L : Total basic rated life of bearing as a whole, h
 $L_1, L_2 \dots L_n$: Individual basic rated life of bearings, 1, 2, ..., n, h

2.3 Bearing-applied machines and requisite life

In selecting a bearing, it is essential to set up the requisite life of the bearing under the intended operating conditions, but the requisite life is mainly determined by the durability period and in-running reliability required for a machine to which the bearing is applied. In general, the requisite lifetime as a guideline is as shown in **Table 2.1**.

The fatigue life of bearing is an important factor to decide the bearing size to be applied. In addition to this factor, however, the strengths and rigidities of shaft and housing must be taken into consideration.

Table 2.1 Operating conditions and requisite lifetime

Operating conditions	Lifetime L_{10h}
Tools and devices requiring no all-time running Ex.) Door switcher, etc.	500
Machines which are operated for a short time or intermittently and do not cause comparatively great affect on others even if they shut down incidentally due to trouble. Ex.) Hand tools, heavy material handling hoist in a machining shop, general hand-operated machines, agricultural machines, crane in a casting shop, material automatic feeder, home appliances, etc.	4 000 ~ 8 000
Machines which are not put in continuous running but required to run very precisely Ex.) Auxiliary machines in a power station, conveyor in a flow process, elevator, general cargo handling crane, machine tool of low frequency in use, etc.	8 000 ~ 14 000
Machines which are operated for 8 hours per day but not put in all-time continuous running Ex.) Power generator in a factory, general geared unit, etc.	14 000 ~ 20 000
Machines which are operated for 8 hours per day Ex.) General machines in a machining shop, crane in all-time operation.	20 000 ~ 30 000
Machines which are put in 24-hour continuous running Ex.) Separator, compressor, pump, main shaft, table roller of rolling mill, conveyor roller, winding engine in a mine, driving motor in a factory, etc.	50 000 ~ 60 000
Machines which are put in 24-hour continuous running and, in addition, are not allowed absolutely trouble shutdown. Ex.) Cellulose manufacturing machine, paper making machine, power station, drainage pump in a mine, urban city water related equipment, etc.	100 000 ~ 200 000

2.4 Bearing life using the adjusted life rating factor

The basic bearing life rating (90% reliability) can be calculated using the formulas prescribed in Subsection 2.2, but on occasion the bearing life of over-90% reliability must be determined on application. Also, the bearing life can be further extended by using a specially improved bearing material and special manufacturing process/technique. Furthermore, it was clarified by the elastohydrodynamic lubrication theory that the bearing life would be influenced by bearing operating conditions (lubrication, temperature, speed, etc.)

The bearing life considering the above factors can be determined by **formula (2.7)** using "Life Adjustment Factor" specified in ISO 281.

$$L_{na} = a_1 \cdot a_2 \cdot a_3 (C/P)^p \dots\dots\dots(2.7)$$

where,

- L_{na} : Adjusted life rating 10^6 revolutions
- a_1 : Reliability adjustment factor
- a_2 : Bearing material adjustment factor
- a_3 : Operating condition adjustment factor

2.4.1 Reliability adjustment factor a_1

The values of reliability adjustment factor a_1 for 90% and higher reliability are as shown in **Table 2.2**.

2.4.2 Life adjustment factor for bearing material a_2

Where bearing material used is special type and quality and manufactured in the special process, the life-related bearing characteristics are inevitably variable depending on the specialties of the material. In such a case, the bearing life is adjusted using the life adjustment factor for bearing material a_2 .

The basic dynamic load ratings described in "Bearing Dimensions Table" are subject to use of the standard

Table 2.2 Values of reliability adjustment factor a_1

Reliability %	L_n	Reliability adjustment factor a_1
90	L_{10}	1.00
95	L_5	0.62
96	L_4	0.53
97	L_3	0.44
98	L_2	0.33
99	L_1	0.21

materials and manufacturing processes / techniques being used in NTN, and usually $a_2=1$ rating is used.

Furthermore, $a_2>1$ is eventually applied to the bearings manufactured using the specially improved material and manufacturing process / technique. In such a case, feel free to contact **NTN** for further instruction.

Where bearings made of high carbon chrome bearing steel are used at 120°C and over throughout a long term, the dimension of the normal heat-treated bearing varies significantly and, therefore, dimension-stabilizing heat-treatment (TS treatment) must be done to the bearings according to the maximum operating temperature. However, this dimension-stabilizing treatment causes the bearing hardness to reduce, finally an inverse affect on the bearing life. To avoid it, the bearing life is adjusted (compensated) by multiplying the life rating by the life adjustment factor for bearing material a_2 shown in **Table 2.3**.

Table 2.3 Values of life adjustment factor for bearing material a_2 for dimension-stabilizing heat-treated (TS-treated) bearings

Code	Maximum operating temperature	Life adjustment factor for bearing material a_2
TS2-	160°C	1.00
TS3-	200°C	0.73
TS4-	250°C	0.48

2.4.3 Life adjustment factor for operating conditions a_3

The life adjustment factor for operating conditions a_3 is used for adjustment(compensation) of the bearing life, where the lubricated bearing condition gets worse and the lubricant deteriorates or foreign matter is included in the bearing, caused by the rotational speed, temperature rise, etc. of the bearing in running.

Generally the life adjustment factor in the case of good lubricated bearing condition is $a_3=1$ and, particularly where the lubricated bearing condition is good and other factors for the bearing are normal, $a_3>1$ can be applied to adjustment of the bearing life. However, $a_3<1$ is applied in the following cases.

• **Low viscosity of lubrication oil under bearing**

- temperature in running
- Radial needle roller bearing 13mm²/s and less
- Thrust needle roller bearing 20mm²/s and less

• **Particularly low rotational speed**

(The product of rotational speed n r/min by pitch circle diameter d_p mm of rolling element is $d_p \cdot n < 10000$.)

• **High operating temperature of bearing**

High operating temperature of bearing would cause the raceway hardness to reduce, whereby bearing life would be shortened. In such a case, the bearing life is adjusted (compensated) by multiplying the value shown in **Fig.2.1** as the life adjustment factor for operating conditions depending on operating temperature.

• **Inclusion of foreign matter in lubricant**

In the case of special operating conditions, feel free to contact NTN for inquiry. For a bearing manufactured using the specially improved material and manufacturing process/technique, usually $a_2 \times a_3 < 1$ is applied unless the lubricating condition is good, even though the life adjustment factor is $a_2 > 1$.

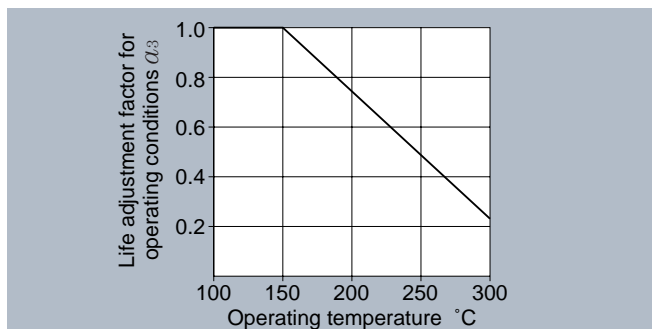

Fig. 2.1 Life adjustment factor for operating conditions depending on operating temperature

2.5 Affect on basic dynamic load rating by raceway surface hardness

When a bearing rolls on shaft surface/housing surface as its raceway surface, the surface layer must be hardened to HRC58 to64 in proper hardening depth.

Ordinary quenching, carburizing or induction quenching, etc. are available as the raceway hardening method, but low hardness of the raceway would cause to the bearing fatigue lifetime to reduce. In such a case, the basic load rating is adjusted by multiplying the hardness factor shown in **Fig.2.2**.

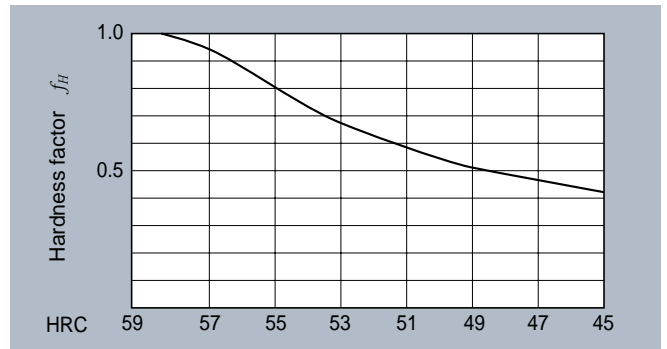

Fig. 2.2 Hardness factor

2.6 Life of bearing with oscillating motion

The life of bearing with oscillating motion can be determined by **formula (2.8)**.

$$L_{osc} = \Omega L_{Rot} \dots \dots \dots (2.8)$$

where,

- L_{osc} : Life of bearing with oscillating motion
- L_{Rot} : Life rating subject to rotational speed r/min identical to oscillation frequency cpm
- Ω : Oscillation factor (showing the relation with half angle β of oscillation angle per **Fig.2.3**).

Generally **Fig.2.3** is applied when the oscillation angle exceeds critical angle 2β . This critical angle is nearly determined by design of bearing internals —mainly the number of rolling elements included in single row bearing.

Where a bearing with oscillating motion is used at below the critical angle, its life is shorter than the lifetime value calculated using **Fig.2.3**. When the critical angle is unknown, determine Ω , assuming $\beta = \beta_c$. Feel free to contact NTN for inquiry about the critical angle of individual bearings.

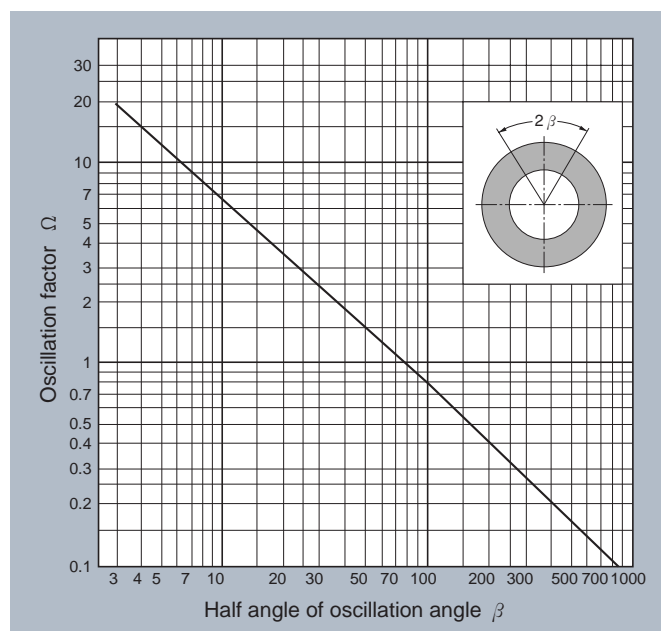

Fig. 2.3 Relationship of oscillation angle β to factor Ω

When the oscillation angle 2β is very small, difficulty in forming an oil film on the contact surface of rolling ring to rolling element could result in fretting corrosion.

In the case of inner ring oscillation, the critical oscillation angle is expressed in **formula (2.9)**.

$$\text{Critical oscillation angle } \theta \geq \frac{360^\circ}{Z} \cdot \frac{d_p}{d_p - D_a \cos \alpha} \dots\dots(2.9)$$

- Where,
 Z : Number of rolling elements (per row)
 d_p : Pitch circle diameter (PCD) of rolling element
 D_p : Rolling element diameter
 e : Contact angle

(In the case of outer ring oscillation, the right side denominator is $d_p + D_a \cos \alpha$.)

2.7 Life of bearing with linear motion

In the case of bearings with linear motion such as linear ball bearing, linear flat roller bearing, etc., the relationship among axial travel distance, bearing load and load rating can be expressed in **formulas (2.10), (2.11)**.

When the rolling elements are balls;

$$L = 50 \times \left(\frac{C_r}{P_r} \right)^3 \dots\dots(2.10)$$

When the rolling elements are rollers;

$$L = 100 \times \left(\frac{C_r}{P_r} \right)^{10/3} \dots\dots(2.11)$$

- where,
 L : Load rating km
 C_r : Basic dynamic load rating N (kgf)
 P_r : Bearing load N (kgf)

Fig.2.4 shows the relationship of C_r/P_r to L . Furthermore, when the travel motion cycle and travel distance remain unchanged, the lifetime of bearing can be determined by **formulas (2.12), (2.13)**.

When the rolling elements are balls;

$$L_h = \frac{50 \times 10^3}{60 \cdot S} \left(\frac{C_r}{P_r} \right)^3 \dots\dots(2.12)$$

When the rolling elements are rollers;

$$L_h = \frac{100 \times 10^3}{60 \cdot S} \left(\frac{C_r}{P_r} \right)^{10/3} \dots\dots(2.13)$$

- where,
 L_h : Travel life h
 S : Travel distance per minute m/min
 $S = 2 \cdot L \cdot n$
 L : Stroke length m
 n : Stroke cycle N (kgf)

2.8 Various factors influencing bearing life

Bearing life is influenced by not only bearing load and rotational speed but also various factors such as lubricating condition, internal clearance, surface roughness and hardness of raceway, heat-treated structure, misalignment, etc. In using bearings, therefore, these influence factors must be taken into full consideration. **Table 2.4** shows the bearing operating conditions as a guideline. (For the detail refer to "Commentary" described in Bearing Dimensions Table every each bearing type.)

Table 2.4 Guideline of the bearing operating conditions

Allowable rotational speed (r/min)	See Dimensions Table
Surface roughness of raceway	within 0.2a
Surface hardness of raceway	HRC58 to 64 Note: Refer to Subsection 7.5 for various materials and heat-treated hardness thereof.
Misalignment	1/2000 or less (for radial bearing)
Radial internal clearance	Ordinary level (C2, C3, C4)

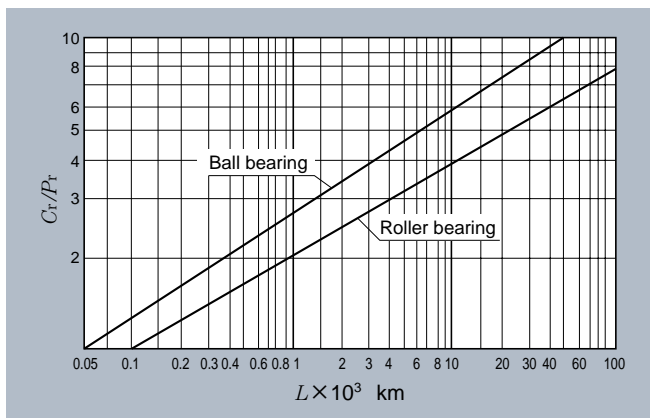

Fig. 2.4 Life of bearing with axial motion

2.9 Fitting misalignment and crowning

Generally it is well known that stress concentration at edge portion (so called, edge load) arising from fitting misalignment would result in rapid reduction of bearing lifetime. "Crowning" is adopted as a countermeasure against such rapid reduction of bearing lifetime. In that case, however, unless it is designed properly this crowning would cause the effective contact length of roller to reduce, which could then lead to shorter life of bearing. It is therefore necessary to calculate a proper crowning value though depending on the extent of fitting misalignment.

And load condition. For reference, **Figs.2.5 to 2.7** show the examples of contact surface pressure analysis by a computer.

As seen from **Figs.2.5 to 2.7** (Examples of contact surface pressure analysis), the rollers with no crowning have high edge surface pressure, while the rollers with crowning restrain the edge surface pressure lower in the range of specific allowable fitting misalignment. **Fig.2.8** shows the relationship of allowable fitting misalignment to bearing lifetime. (example of computer analysis) It is possible to see from this Figure how the bearing lifetime is influenced by fitting misalignment.

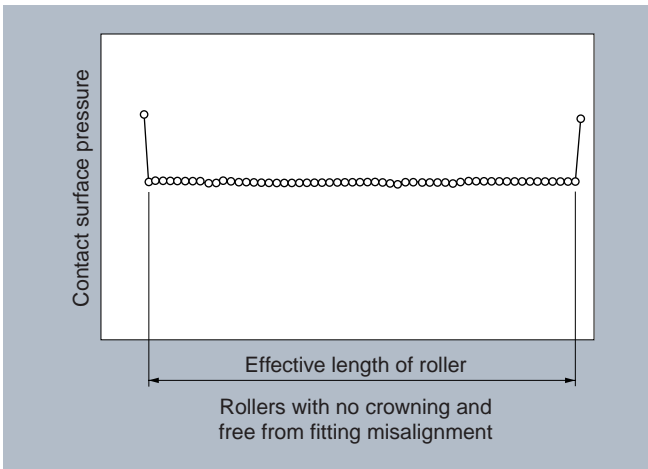

Fig. 2.5

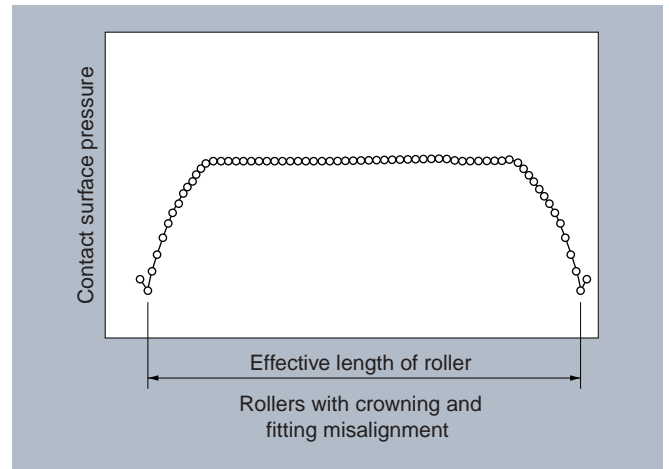

Fig. 2.7

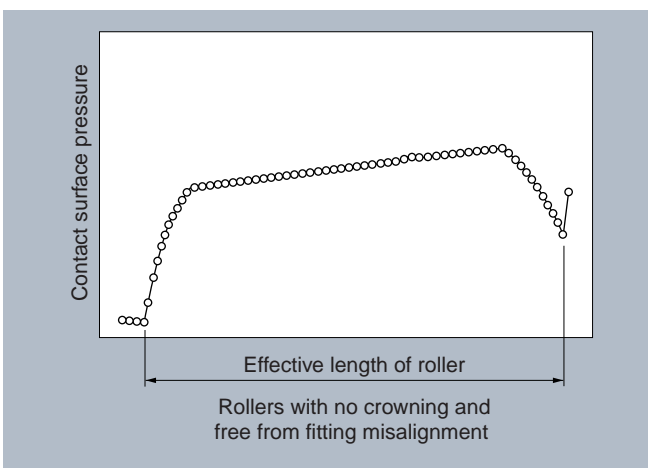

Fig. 2.6

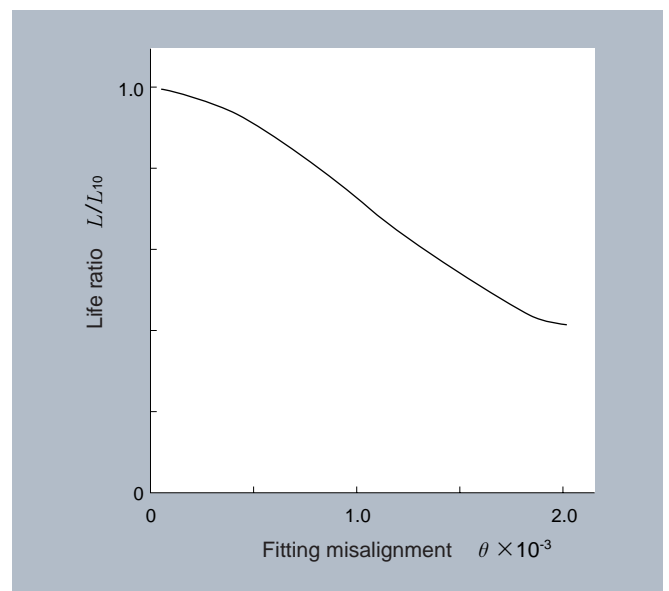

Fig. 2.8 Relationship of fitting misalignment to bearing lifetime

2.10 Radial internal clearance, surface roughness and surface hardness, and bearing life

The relationship of radial internal clearance to bearing life is as shown in Fig. 2.9 and the relationship of surface roughness to bearing life as shown in Fig.2.10.

It is possible to see from these Figures how the bearing life is influenced by each factor.

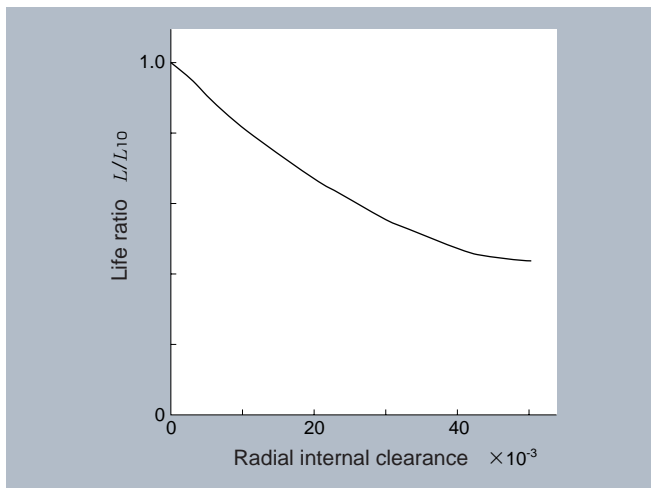

Fig. 2.9 Relationship of radial internal clearance to bearing life

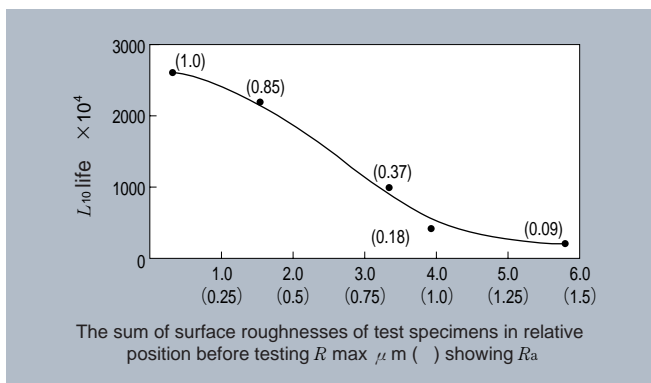

Fig. 2.10 Relationship of surface roughness to bearing life

2.11 Basic static load rating

Load acting on a bearing, when acted, results in locally permanent deformation of the contract surface of rolling elements to bearing ring. And this deformation value increases inevitably with the increasing load and smooth rotation of the bearing is interfered with by the deformation when it exceeded a certain limit value.

It is known experimentally that the total permanent deformation value 0.0001 times as large as the rolling element diameter at the contact center of rolling elements to raceway both of which are subjected to maximum stress is an allowable deformation limit which does not interfere with smooth rotation of bearing.

"Basic static load rating" is defined as such a constant static load that results in permanent deformation of the said limit value, which is then expressed in net radial load for radial bearings and in net axial load for thrust bearings.

Regarding this load value, each table of bearing dimensions describes it in the C_{or}, field for radial bearings and in C_{oa} field for thrust bearings respectively.

When the load defined above acts on a bearing, contact stress at the contact center of rolling element to raceway, which are subjected to maximum load, reaches the following value.

- For roller bearing4000MPa (408kgf/mm²)
- For ball bearing4200MPa (428kgf/mm²)

2.12 Allowable static bearing load

The basic static load rating prescribed in Subsection 2.11 is generally deemed as an allowable static bearing limit load, but in some cases this allowable limit load is set up larger than the basic static load rating and in some other cases it is set up smaller, according to the requirements for revolving smoothness and friction.

Generally this allowable limit load is decided considering the safety factor S_o in the following formula (2.14) and Table 2.5.

$$S_o = C_o / P_o \dots\dots\dots(2.14)$$

where,

- S_o : Safety factor
- C_o : Basic static rated load, N (kgf)
(For radial bearings: C_{or},
For thrust bearings: C_{oa})
- P_{o max} : Maximum static bearing load, N (kgf)
(For radial bearings: P_{or max},
For thrust bearings: C_{oa max})

Table 2.5 Lower limit value of safety factor S_o

Operating conditions	Roller bearings	Ball bearings
Requirement for high revolving accuracy	3	2
Requirement for ordinal revolving accuracy (ordinary-purposed)	1.5	1
Where minor deterioration of revolving accuracy is allowed (Ex. Low speed revolution, duty load application, etc.)	1	0.5

- Remarks: 1. For the drawn-cup needle roller bearings, 3 shall be adopted as S_o lower limit value.
- 2. Where vibration and shock load act on bearing, P_{o max} shall be determined considering the shock load factor.

3. Calculation of Bearing Loads

3.1 Load acting on shafts

The loads acting on the shaft to be supported with the bearing must be determined for calculation of bearing loads. These loads include the self-weight of rotor assy, loads inevitably resulting from a machine in running, loads arising from power transmission, etc. These loads are mostly difficult to calculate though some of them can be calculated numerically and theoretically.

The following paragraphs describe how to calculate the loads acting on a power transmission shaft as one of the main bearing applications.

3.1.1 Load acting on gears

The loads acting on gears can be divided into tangential load (K_t), radial load (K_s) and axial load (K_a). The magnitude and acting direction of each load differ depending on the types of gear. This paragraph describes how to calculate the loads acting on parallel shaft gears and cross shaft gears for general use. For calculation of the loads acting on other gears, feel free to contact NTN for inquiry.

(1) Load acting on parallel shaft gear

Figs. 3.1 to 3.3 illustrate the loads acting on spur gear and helical gear which are used with a parallel shaft. The magnitude of each load can be determined using the **formulas (3.1) to (3.4)**.

$$K_t = \frac{19.1 \times 10^6 \cdot HP}{D_p \cdot n} \left(\frac{1.95 \times 10^6 \cdot HP}{D_p \cdot n} \right) \dots\dots\dots (3.1)$$

$$K_s = K_t \cdot \tan \alpha \text{ (Spur gear)} \dots\dots\dots (3.2a)$$

$$= K_t \cdot \frac{\tan \alpha}{\cos \beta} \text{ (for helical gear)} \dots\dots\dots (3.2b)$$

$$K_r = \sqrt{K_t^2 + K_s^2} \dots\dots\dots (3.3a)$$

$$K_a = K_t \cdot \tan \beta \text{ (for helical gear)} \dots\dots\dots (3.4)$$

where,

- K_t : Tangential load acting on gear (Tangential force) N (kgf)
- K_s : Radial load acting on gear (separating force) N (kgf)
- K_r : Load acting perpendicularly on gear shaft (composite force of tangential force and separating force) N (kgf)
- K_a : Parallel load acting on gear shaft N (kgf)
- HP : Transmission power kw
- n : Rotational speed r/min
- D_p : Pitch circle diameter of gear mm
- α : Gear pressure angle
- β : Gear helix angle

Actual gear load is determined by multiplying the theoretical load by the gear factor described in **Table 3.1**, because vibration and shock are added to each theoretical load determined by the above formulas.

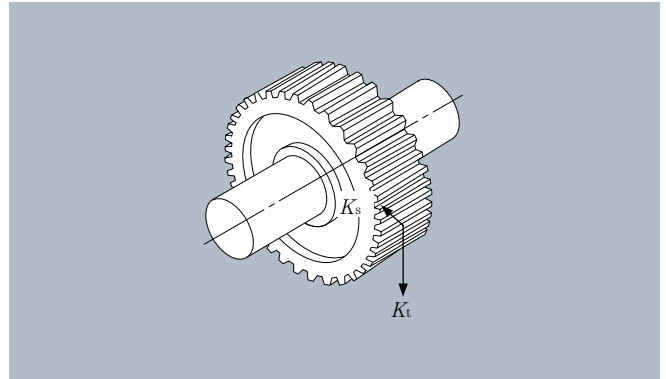

Fig. 3.1 Load acting on spur gear

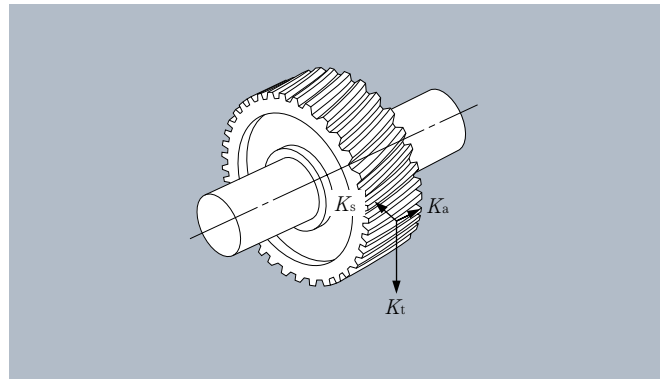

Fig. 3.2 Load acting on helical gear

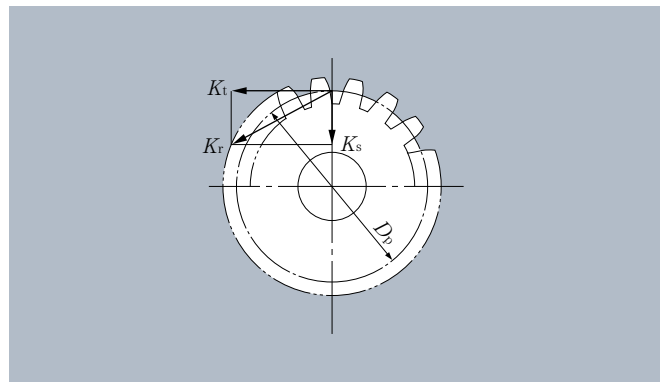

Fig. 3.3 Composite radial force acting on gear

Table 3.1 Gear factor f_z

Types of gear	f_z
Precision ground gears (Pitch and profile errors of less than 0.02mm)	1.05~1.1
Ordinary machined gears (Pitch and profile errors of less than 0.1mm)	1.1~1.3

(2) Loads acting on cross shaft gears

Figs. 3.4 and **3.5** illustrate the loads acting on straight-tooth bevel gears and spiral bevel gears which are used with cross shafts.

Table 3.2 shows how to calculate these loads.

The load acting on straight-tooth bevel gear can be determined from **Table 3.2**, assuming the helix angle as $\beta = 0$.

The symbols and units used in this table are as follows.

- K_t : Tangential load acting on gear (Tangential force) N (kgf)
- K_s : Radial load acting on gear (separating force) N (kgf)
- K_a : Parallel load acting on gear shaft (axial load) N (kgf)
- HP : Transmission power kw
- n : Rotational speed r/min
- D_{pm} : Mean pitch circle diameter mm
- α : Gear pressure angle
- β : Gear helix angle
- δ : Pitch cone angle of gear

In general, the relationship between the loads acting on pinion and pinion gear can be expressed as follows, due to the perpendicular intersection of two shafts.

$$K_{sp} = K_{ag} \dots\dots\dots (3.5)$$

$$K_{ap} = K_{sg} \dots\dots\dots (3.6)$$

where,

K_{sp}, K_{sg} : Pinion and pinion gear separating force N (kgf)

K_{ap}, K_{ag} : Axial load acting on pinion and pinion gear N (kgf)

For spiral bevel gears, the loading direction differs depending on the direction of helix angle, rotational direction and whether the spiral bevel gear is located at the drive side or the driven side.

The separating force (K_s) acting direction and axial load (K_a) acting direction illustrated in **Fig.3.5** are the positive direction respectively. On the other hand, the rotational direction and helix angle direction are to be defined when viewing from the large end side of the gear. Hence, for the gear illustrated in **Fig. 3.5** these directions are clockwise and to right.

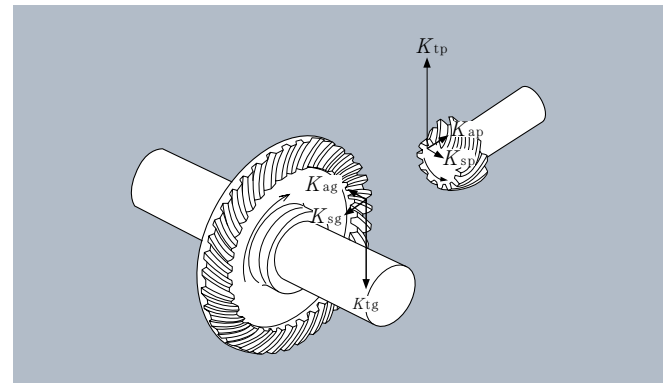

Fig. 3.4 Load acting on bevel gears

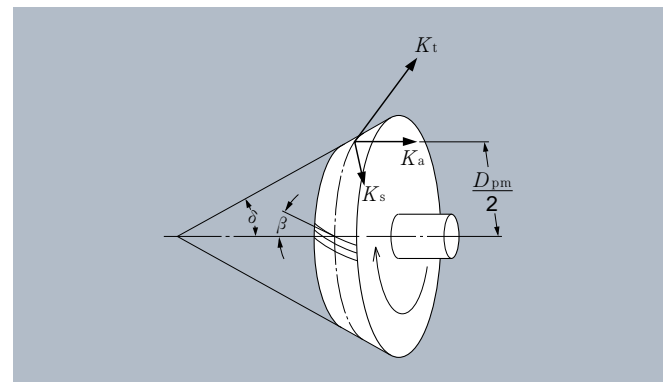

Fig.3.5 Bevel gear diagram

Table 3.2 Loads acting on bevel gears

Unit N

Driving gears	Rotational direction	Clockwise	Counter clockwise	Clockwise	Counter clockwise
	Helix angle	To right	To left	To left	To right
Tangential load K_t		$K_t = \frac{19.1 \times 10^6 \cdot H}{D_{pm} \cdot n}, \left\{ \frac{1.95 \times 10^6 \cdot H}{D_{pm} \cdot n} \right\}$			
Separating force K_s	Drive side	$K_s = K_t \left[\tan \alpha \frac{\cos \delta}{\cos \beta} + \tan \beta \sin \delta \right]$	$K_s = K_t \left[\tan \alpha \frac{\cos \delta}{\cos \beta} - \tan \beta \sin \delta \right]$	$K_s = K_t \left[\tan \alpha \frac{\cos \delta}{\cos \beta} - \tan \beta \sin \delta \right]$	$K_s = K_t \left[\tan \alpha \frac{\cos \delta}{\cos \beta} + \tan \beta \sin \delta \right]$
	Driven side	$K_s = K_t \left[\tan \alpha \frac{\cos \delta}{\cos \beta} - \tan \beta \sin \delta \right]$	$K_s = K_t \left[\tan \alpha \frac{\cos \delta}{\cos \beta} + \tan \beta \sin \delta \right]$	$K_s = K_t \left[\tan \alpha \frac{\cos \delta}{\cos \beta} + \tan \beta \sin \delta \right]$	$K_s = K_t \left[\tan \alpha \frac{\cos \delta}{\cos \beta} - \tan \beta \sin \delta \right]$
Axial load K_a	Drive side	$K_a = K_t \left[\tan \alpha \frac{\sin \delta}{\cos \beta} - \tan \beta \cos \delta \right]$	$K_a = K_t \left[\tan \alpha \frac{\sin \delta}{\cos \beta} + \tan \beta \cos \delta \right]$	$K_a = K_t \left[\tan \alpha \frac{\sin \delta}{\cos \beta} + \tan \beta \cos \delta \right]$	$K_a = K_t \left[\tan \alpha \frac{\sin \delta}{\cos \beta} - \tan \beta \cos \delta \right]$
	Driven side	$K_a = K_t \left[\tan \alpha \frac{\sin \delta}{\cos \beta} + \tan \beta \cos \delta \right]$	$K_a = K_t \left[\tan \alpha \frac{\sin \delta}{\cos \beta} - \tan \beta \cos \delta \right]$	$K_a = K_t \left[\tan \alpha \frac{\sin \delta}{\cos \beta} - \tan \beta \cos \delta \right]$	$K_a = K_t \left[\tan \alpha \frac{\sin \delta}{\cos \beta} + \tan \beta \cos \delta \right]$

3.1.2 Loads acting on chain and belt shafts

In the case of power transmission by a chain and a belt, the load acting tangentially on the sprocket or the pulley can be determined by **formula (3.7)**.

$$K_t = \frac{19.1 \times 10^6 \cdot HP}{D_p \cdot n} \left(\frac{1.95 \times 10^6 \cdot HP}{D_p \cdot n} \right) \dots \dots \dots (3.7)$$

where,

- K_t : Tangential load acting on sprocket or pulley N (kgf)
- HP : Transmission power kW
- D_p : Pitch circle diameter of sprocket or pulley mm

In the case of belt driving, initial tension is applied to the belt so the pulley and the belt are both always pressed down with a proper load.

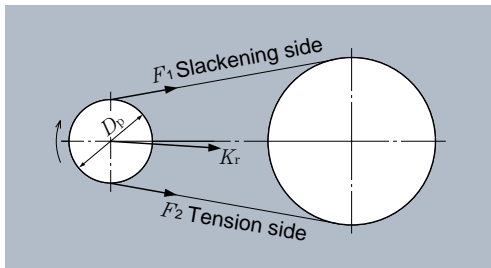

Fig. 3.6 Loads acting on chain/ belt

Considering this initial tension, radial load acting on the pulley is expressed in **formula (3.8)**.

In the case of chain driving, the radial load acting thereon can be expressed using the same formula, if vibration and shock are taken into consideration.

$$K_r = f_b \cdot K_t \dots \dots \dots (3.8)$$

where,

- K_r : Radial load acting on sprocket or pulley N (kgf)
- f_b : Chain/belt factor (Table 3.3)

Table 3.3 Chain/belt factor f_b

Type of chain / belt	f_b
Chain (single row type)	1.2~1.5
Vee-belt	1.5~2.0
Timing belt	1.1~1.3
Flat belt (with tension pulley)	2.5~3.0
Flat belt	3.0~4.0

3.1.3 Load factor

In an actual machine, the shaft load is mostly greater than the theoretically calculated load due to vibration, shock, etc. The load acting on the shafts of a machine can be determined by **formula (3.9)**.

$$K = f_w \cdot K_C \dots \dots \dots (3.9)$$

where

- K : Actual load acting on shaft N(kgf)
- K_C : Theoretically calculated value N (kgf)
- f_w : Load factor (Table 3.4)

Table 3.4 Load factor f_w

Extent of shock	f_w	Application
Nearly no shock	1.0~1.2	Electrical machines, machine tools, measuring instruments
Light shock	1.2~1.5	Railway vehicles, automobiles, rolling mills, metal working machines, paper making machines, rubber mixing machines, printing machines, aircraft, textile machines, electrical units, office equipment
Heavy shock	1.5~3.0	Crushers, agricultural machines, construction machines, cranes

3.2 Load distribution to bearings

Any loads acting on shafts are distributed to the bearings considering static tension to be supported with the bearings.

For example, the loads acting on the bearings in the gear shaft illustrated in **Fig. 3.7** can be expressed in **formulas (3.10) and (3.11)**.

$$F_{rA} = K_{rI} \frac{b}{l} - K_{rII} \frac{c}{l} - K_a \frac{D_p}{2l} \dots \dots \dots (3.10)$$

$$F_{rB} = K_{rI} \frac{a}{l} + K_{rII} \frac{a+b+c}{l} + K_a \frac{D_p}{2l} \dots \dots \dots (3.11)$$

where,

- F_{rA} : Radial load acting on bearing-A N (kgf)
- F_{rB} : Radial load acting on bearing-B N (kgf)
- K_{rI} : Radial load acting on gear-I N (kgf)
- K_a : Axial load acting on gear-I N (kgf)
- K_{rII} : Axial load acting on gear-II N (kgf)
- D_p : Pitch circle diameter of gear-I mm
- l : Bearing to bearing distance mm

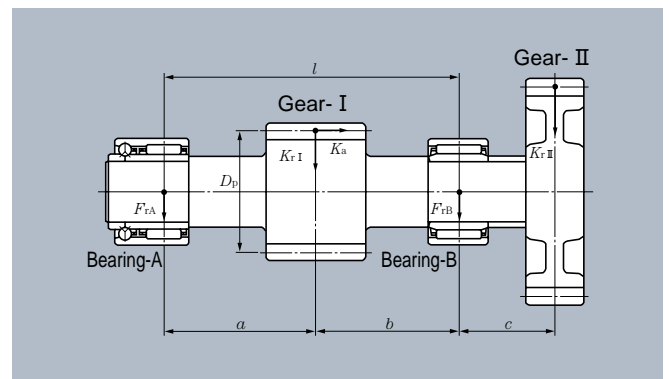

Fig. 3.7 Gear shaft

3.3 Mean load

The loads acting on bearings used in ordinary machines fluctuate mostly depending on the predetermined operation cycle or work plan. In such a case, the mean load F_m converted so the same lifetime is assigned to the bearings is used as the bearing load.

(1) Stepped fluctuating load

Where bearing loads F_1, F_2, \dots, F_n act on and the rotational speed and running time are n_1, n_2, \dots, n_n and t_1, t_2, \dots, t_n respectively, the mean load F_m of these loads can be expressed in **formula (3.12)**.

$$F_m = \left(\frac{\sum (F_i^p n_i t_i)}{\sum (n_i t_i)} \right)^{1/p} \dots \dots \dots (3.12)$$

where:

- $p = 10/3$ for roller bearing
- $p = 3$ for ball bearing

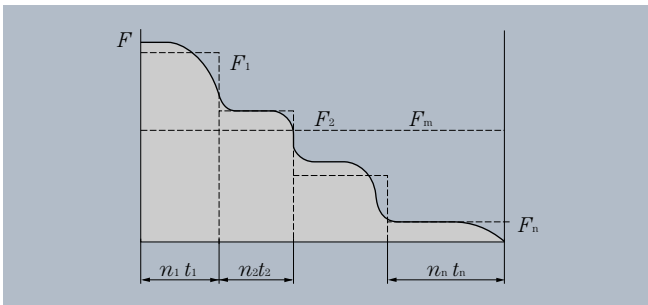

Fig. 3.8 Stepped fluctuating load

(2) Consecutive series load

Where load is load cycle " t_0 " and it can be expressed in the function $F(t)$ of time t , the mean load can be expressed in **formula (3.13)**.

$$F_m = \left(\frac{1}{t_0} \int_0^{t_0} F(t)^p dt \right)^{1/p} \dots \dots \dots (3.13)$$

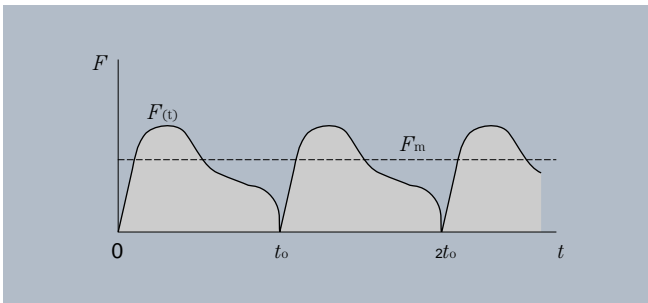

Fig. 3.9 Load fluctuating as a time function

(3) Load fluctuating in nearly linear form

The mean load F_m can be determined approximately by **formula (3.14)**.

$$F_m = \frac{F_{\min} + 2F_{\max}}{3} \dots \dots \dots (3.14)$$

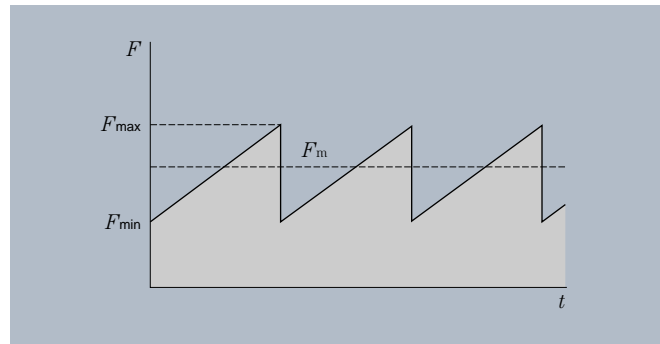

Fig. 3.10 Load fluctuating in linear form

(4) Sinusoidal fluctuating load

The mean load F_m can be determined approximately by **formulas (3.15), (3.16)**.

case of (a) $F_m = 0.75 F_{\max} \dots \dots \dots (3.15)$

case of (b) $F_m = 0.65 F_{\max} \dots \dots \dots (3.16)$

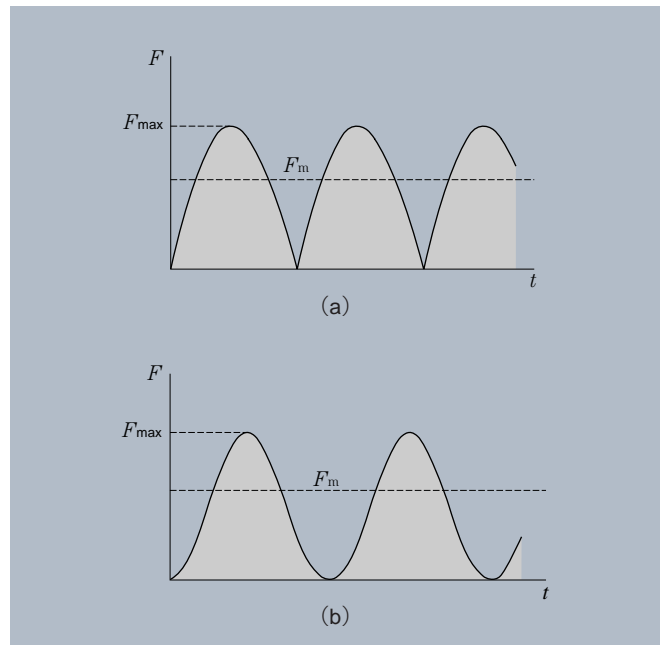

Fig. 3.11 Sinusoidal fluctuating load



4. Bearing Accuracy

The dimensional, profile and running accuracies of rolling bearings are specified in ISO Standard as applicable and JIS B 1514 (Accuracy of Rolling Bearings).

"Dimensional accuracy" and "Profile accuracy" are the items indispensable in installing the rolling bearings on a shaft and in a bearing housing, and allowable bearing run-out in running is specified as the running accuracy.

Dimensional accuracy:

Dimensional accuracy means the respective allowable values for bore diameter, outer diameter, width or height (limited to thrust bearing) and chamfering dimension.

Profile accuracy:

This means the allowable value for variation of each of bore diameter, mean bore diameter, outer diameter, mean outer diameter, and width or thickness of bearing ring (limited to thrust bearing).

Running accuracy:

This means the respective allowable values for radial run-out and axial run-out of both inner ring and outer ring, lateral run-out of inner ring, and outer diameter run-out of outer ring.

Regarding the accuracy class of the machined ring needle roller bearings, class-0 is equivalent to bearings of the normal precision class, and precision becomes progressively higher as the class number becomes smaller; i.e. Class 6 is less precise than Class 5, which is less precise than Class 4, and so on.

Bearings of Class-0 are mostly used for general application, while bearings of Class-5 or Class-4 are used, where the required running accuracies and revolutions are high or less friction and less fluctuation are required for bearings.

Various bearing types are available for NTN needle roller bearings and the representative types and the accuracy classes applicable to them are as shown in **Table 4.1**.

Dimensional item symbols used in the accuracy standard are given in **Table 4.2**, the radial bearing accuracy specified every accuracy class given in **Table 4.3**, the thrust bearing accuracy specified every accuracy class given in **Table 4.4**, and the allowable values for chamfering dimension given in **Table 4.5**.

Table 4.2 Dimensional item symbols used in applicable standards

Classification	Symbols	Symbol representation	Symbols under JIS B 0021 (Reference)
Dimensional accuracy	Δd_{mp}	Dimensional tolerance for in-plane mean bore diameter	_____
	Δd_s	Dimensional tolerance for bore diameter	_____
	ΔD_{mp}	Dimensional tolerance for in-plane mean outer diameter	_____
	ΔD_s	Dimensional tolerance for outer diameter	_____
	ΔB_s	Dimensional tolerance for inner ring width	_____
	ΔC_s	Dimensional tolerance for outer ring width	_____
Profile accuracy	V_{dp}	Variation of in-plane bore diameter	Roundness \bigcirc ¹⁾
	V_{dmp}	Variation of in-plane mean bore diameter	Cylindricity \bigcirc ²⁾
	V_{Dp}	Variation of in-plane outer diameter	Roundness \bigcirc ¹⁾
	V_{Dmp}	Variation of in-plane mean outer diameter	Cylindricity \bigcirc ²⁾
	V_{Bs}	Variation of inner ring width	Parallelism $//$
	V_{Cs}	Variation of outer ring width	Parallelism $//$
Running accuracy	K_{ia}	Radial run-out of inner ring	Run-out \nearrow
	K_{ea}	Radial run-out of outer ring	Run-out \nearrow
	S_{ia}	Axial run-out of inner ring	_____
	S_{ea}	Axial run-out of outer ring	_____
	S_d	Lateral run-out (inner ring)	Run-out \nearrow
	S_D	Outer diameter run-out (outer ring)	Run-out \nearrow

1) The roundness specified in JIS B 0021 is applicable to the tolerance V_{dp} for variation of radial in-plane bore diameter or nearly half of V_{Dp} .

2) The cylindricity specified in JIS B 0021 is applicable to the tolerance V_{dmp} for in-uniformity of radial in-plane mean diameter or nearly half of V_{Dmp} .

Table 4.1 Bearing types and corresponding accuracy classes

Bearing type		Applicable accuracy class				Applicable table
Needle roller bearing, Clearance-adjustable needle roller bearing		JIS Class-0 —	JIS Class-6 —	JIS Class-5 —	JIS class-4 JIS class-4	Table 4.3 Table 4.3
Complex bearing	Radial bearing	JIS Class-0	JIS Class-6	JIS Class-5	—	Table 4.3 Table 4.4
	Thrust bearing	NTN Class 0	NTN Class 6	NTN Class 5	NTN Class 4	
Needle roller bearing with double-direction thrust roller bearing	Radial bearing	—	—	JIS Class-5	JIS Class-4	Table 4.3 Table 4.4
	Thrust bearing	—	—	NTN Class 5	NTN Class 4	
Thrust roller bearing		NTN Class 0	NTN Class 6	NTN Class 5	NTN Class 4	Table 4.4
Roller follower/cam follower		JIS Class-0	—	—	—	Table 4.3

Table 4.3 Tolerances for radial bearings
Table 4.3(1) Inner rings

Nominal bore diameter d mm		Dimensional tolerance for mean bore diameter Δ_{dmp}								Variation of mean bore diameter V_{dp}				Allowable variation of bore diameter V_{dmp}			
over	incl.	Class 0		Class 6		Class 5		Class 4		Class 0	Class 6	Class 5	Class 4	Class 0	Class 6	Class 5	Class 4
		high	low	high	low	high	low	high	low								
2.5 ^①	10	0	-8	0	-7	0	-5	0	-4	10	9	5	4	6	5	3	2
10	18	0	-8	0	-7	0	-5	0	-4	10	9	5	4	6	5	3	2
18	30	0	-10	0	-8	0	-6	0	-5	13	10	6	5	8	6	3	2.5
30	50	0	-12	0	-10	0	-8	0	-6	15	13	8	6	9	8	4	3
50	80	0	-15	0	-12	0	-9	0	-7	19	15	9	7	11	9	5	3.5
80	120	0	-20	0	-15	0	-10	0	-8	25	19	10	8	15	11	5	4
120	150	0	-25	0	-18	0	-13	0	-10	31	23	13	10	19	14	7	5
150	180	0	-25	0	-18	0	-13	0	-10	31	23	13	10	19	14	7	5
180	250	0	-30	0	-22	0	-15	0	-12	38	28	15	12	23	17	8	6
250	315	0	-35	0	-25	0	-18	—	—	44	31	18	—	26	19	9	—
315	400	0	-40	0	-30	0	-23	—	—	50	38	23	—	30	23	12	—
400	500	0	-45	0	-35	—	—	—	—	56	44	—	—	34	26	—	—

① 2.5mm is included in this dimensional category.

② This table is applied to the ball bearings.

Table 4.3 (2) Outer rings

Nominal outer diameter D mm		Dimensional tolerance for mean outer diameter Δ_{Dmp}								Allowable variation of outer diameter V_{Dp}				Allowable variation of mean outer diameter V_{Dmp}			
over	incl.	Class 0		Class 6		Class 5		Class 4		Class 0	Class 6	Class 5	Class 4	Class 0	Class 6	Class 5	Class 4
		high	low	high	low	high	low	high	low								
6 ^②	18	0	-8	0	-7	0	-5	0	-4	10	9	5	4	6	5	3	2
18	30	0	-9	0	-8	0	-6	0	-5	12	10	6	5	7	6	3	2.5
30	50	0	-11	0	-9	0	-7	0	-6	14	11	7	6	8	7	4	3
50	80	0	-13	0	-11	0	-9	0	-7	16	14	9	7	10	8	5	3.5
80	120	0	-15	0	-13	0	-10	0	-8	19	16	10	8	11	10	5	4
120	150	0	-18	0	-15	0	-11	0	-9	23	19	11	9	14	11	6	5
150	180	0	-25	0	-18	0	-13	0	-10	31	23	13	10	19	14	7	5
180	250	0	-30	0	-20	0	-15	0	-11	38	25	15	11	23	15	8	6
250	315	0	-35	0	-25	0	-18	0	-13	44	31	18	13	26	19	9	7
315	400	0	-40	0	-28	0	-20	0	-15	50	35	20	15	30	21	10	8
400	500	0	-45	0	-33	0	-23	—	—	56	41	23	—	34	25	12	—
500	630	0	-50	0	-38	0	-28	—	—	63	48	28	—	38	29	14	—

① 6mm is included in this dimensional category.

② This table is applied to the ball bearings.

Unit μm

Radial run-out K_{ia}				Face run-out S_d		Axial run-out S_{ia} ②		Allowable width deviation Δ_{Bs}				Allowable width variation V_{Bs}				Nominal bore diameter d mm	
Class 0	Class 6	Class 5	Class 4	Class 5	Class 4	Class 5	Class 4	Class 0,6		Class 5,4		Class 0	Class 6	Class 5	Class 4	over	incl.
max				max		max		high	low	high	low	max					
10	6	4	2.5	7	3	7	3	0	-120	0	-40	15	15	5	2.5	2.5 ^①	10
10	7	4	2.5	7	3	7	3	0	-120	0	-80	20	20	5	2.5	10	18
13	8	4	3	8	4	8	4	0	-120	0	-120	20	20	5	2.5	18	30
15	10	5	4	8	4	8	4	0	-120	0	-120	20	20	5	3	30	50
20	10	5	4	8	5	8	5	0	-150	0	-150	25	25	6	4	50	80
25	13	6	5	9	5	9	5	0	-200	0	-200	25	25	7	4	80	120
30	18	8	6	10	6	10	7	0	-250	0	-250	30	30	8	5	120	150
30	18	8	6	10	6	10	7	0	-250	0	-250	30	30	8	5	150	180
40	20	10	8	11	7	13	8	0	-300	0	-300	30	30	10	6	180	250
50	25	13	—	13	—	15	—	0	-350	0	-350	35	35	13	—	250	315
60	30	15	—	15	—	20	—	0	-400	0	-400	40	40	15	—	315	400
65	35	—	—	—	—	—	—	0	-450	—	—	50	45	—	—	400	500

 Unit μm

Radial run-out K_{ea}				Outside surface inclination S_D		Axial run-out S_{ea} ①		Allowable width deviation Δ_{Cs}				Allowable width variation V_{Cs}				Nominal outer diameter D mm			
Class 0	Class 6	Class 5	Class 4	Class 5	Class 4	Class 5	Class 4	Class 0,6,5,4				Class 0	Class 6	Class 5	Class 4	over	incl.		
max				max		max						max							
15	8	5	3	8	4	8	5	Depending on the tolerance of Δ_{Bs} for d of same bearing.								6 ^③	18		
15	9	6	4	8	4	8	5					Depending on the applicable				5	2.5	18	30
20	10	7	5	8	4	8	5					value of V_{Bs}				5	2.5	30	50
25	13	8	5	8	4	10	5					for d of same bearing.				6	3	50	80
35	18	10	6	9	5	11	6									8	4	80	120
40	20	11	7	10	5	13	7									8	5	120	150
45	23	13	8	10	5	14	8									8	5	150	180
50	25	15	10	11	7	15	10									10	7	180	250
60	30	18	11	13	8	18	10									11	7	250	315
70	35	20	13	13	10	20	13									13	8	315	400
80	40	23	—	15	—	23	—					15	—	400	500				
100	50	25	—	18	—	25	—					18	—	500	630				

Table 4.4 Tolerances of thrust roller bearings
Table 4.4 (1) Inner rings and center rings

Unit μm

Nominal bore diameter d or d_2 mm		Allowable deviation of mean diameter Δd_{mp} or Δd_{2mp}				Allowable variation of bore diameter V_{d1p} or V_{d2p}		Allowable variation of raceway thickness ^① S_i			
over	incl.	Class 0, 6, 5		Class 4		Class 0, 6, 5 low	Class 4	Class 0	Class 6	Class 5	Class 4
		high	low	high	low						
—	18	0	−8	0	−7	6	5	10	5	3	2
18	30	0	−10	0	−8	8	6	10	5	3	2
30	50	0	−12	0	−10	9	8	10	6	3	2
50	80	0	−15	0	−12	11	9	10	7	4	3
80	120	0	−20	0	−15	15	11	15	8	4	3
120	180	0	−25	0	−18	19	14	15	9	5	4
180	250	0	−30	0	−22	23	17	20	10	5	4
250	315	0	−35	0	−25	26	19	25	13	7	5
315	400	0	−40	0	−30	30	23	30	15	7	5
400	500	0	−45	0	−35	34	26	30	18	9	6
500	630	0	−50	0	−40	38	30	35	21	11	7

① The complex bearings are applicable to the category of single plane bearing d which corresponds to the same nominal outer diameter of same diameter series, without being applicable to d_2 category.

Table 4.4 (2) Outer rings

Unit μm

Nominal outer diameter D mm		Allowable deviation of mean outer diameter ΔD_{mp}				Allowable variation of outer diameter V_{Dp}		Allowable variation of raceway thickness S_e
over	incl.	Class 0,6,5		Class 4		Class 0,6,5 max	Class 4	Class 0,6,5,4 max
		high	low	high	low			
10	18	0	−11	0	−7	8	5	Depending on the applicable allowable value of S_1 for d or d_2 of same bearing.
18	30	0	−13	0	−8	10	6	
30	50	0	−16	0	−9	12	7	
50	80	0	−19	0	−11	14	8	
80	120	0	−22	0	−13	17	10	
120	180	0	−25	0	−15	19	11	
180	250	0	−30	0	−20	23	15	
250	315	0	−35	0	−25	26	19	
315	400	0	−40	0	−28	30	21	
400	500	0	−45	0	−33	34	25	
500	630	0	−50	0	−38	38	29	
630	800	0	−75	0	−45	55	34	

Table 4.5 Allowable critical value for chamfering dimension

Table 4.5 (1) Radial bearings

Unit mm

r_s min	Nominal bore diameter d		Radial direction	Axial direction
	over	incl.		
0.15	—	—	0.3	0.6
0.2	—	—	0.5	0.8
0.3	—	40	0.6	1
	40	—	0.8	1
0.6	—	40	1	2
	40	—	1.3	2
1	—	50	1.5	3
	50	—	1.9	3
1.1	—	120	2	3.5
	120	—	2.5	4
1.5	—	120	2.3	4
	120	—	3	5
2	—	80	3	4.5
	80	220	3.5	5
2.1	—	220	3.8	6
	220	—	4	6.5
2.5	—	280	4.5	7
	280	—	3.8	6
3	—	100	5	8
	100	280	4.5	6
4	—	280	5.5	8
	280	—	6.5	9

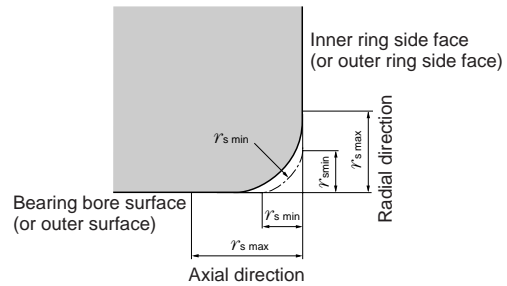

Table 4.5 (2) Thrust bearings

Unit mm

r_s min	Radial and axial directions
	r_s max
0.3	0.8
0.6	1.5
1	2.2
1.1	2.7
1.5	3.5
2	4
2.1	4.5
3	5.5

① Allowable minimum values for the chamfering dimension " r_s ".

① Allowable minimum values for the chamfering dimension " r_s ".

Table 4.6 Basic tolerances

Unit μ m

Basic dimension (mm)		IT basic tolerance classes									
over	incl.	IT1	IT2	IT3	IT4	IT5	IT6	IT7	IT8	IT9	IT10
3	3	0.8	1.2	2	3	4	6	10	14	25	40
3	6	1	1.5	2.5	4	5	8	12	18	30	48
6	10	1	1.5	2.5	4	6	9	15	22	36	58
10	18	1.2	2	3	5	8	11	18	27	43	70
18	30	1.5	2.5	4	6	9	13	21	33	52	84
30	50	1.5	2.5	4	7	11	16	25	39	62	100
50	80	2	3	5	8	13	19	30	46	74	120
80	120	2.5	4	6	10	15	22	35	54	87	140
120	180	3.5	5	8	12	18	25	40	63	100	160
180	250	4.5	7	10	14	20	29	46	72	115	185
250	315	6	8	12	16	23	32	52	81	130	210
315	400	7	9	13	18	25	36	57	89	140	230
400	500	8	10	15	20	27	40	63	97	155	250
500	630	9	11	16	22	30	44	70	110	175	280
630	800	10	13	18	25	35	50	80	125	200	320
800	1 000	11	15	21	29	40	56	90	140	230	360
1 000	1 250	13	18	24	34	46	66	105	165	260	420
1 250	1 600	15	21	29	40	54	78	125	195	310	500
1 600	2 000	18	25	35	48	65	92	150	230	370	600
2 000	2 500	22	30	41	57	77	110	175	280	440	700
2 500	3 150	26	36	50	69	93	135	210	330	540	860

5. Bearing Internal Clearance

5.1 Radial clearance

Radial clearance in bearing (initial radial clearance) means the displacement value of bearing ring when the non-fixed ring was displaced in radial direction with either one of the inner ring and outer ring remained fixed, before the bearing is installed on a shaft or in a housing.

Machined ring needle roller bearing (with inner ring) ;

The initial clearance values for this bearing type are as shown in **Table 5.1. Table 5.1 (1)** shows the interchangeable clearances, which are remained unchanged even after inner ring or outer ring was reassembled in. **Table 5.1(2)** shows non-interchangeable clearances, which do not allow reassembly of inner ring or outer ring due to the narrow clearance range. The bearing clearances are represented by the symbols of C2, ordinary, C3 and C4 in the order from the smallest one and the non-interchangeable clearance symbols are followed by "NA" for identification.

For the radial clearance values for bearing types other than the machined ring needle roller bearings, refer to "Commentary" described in the respective Dimensions Table.

5.2 Running clearance

5.2.1 Setting up running clearance

Bearing clearance in running, that is, running clearance gets generally smaller than the initial radial clearance, depending on the fits and temperature difference between the inner ring and the outer ring. This running clearance must be set up optimally because setting up it improperly would lead to shorter life, overheat and vibration or running noise of bearing.

Theoretically the bearing life comes to the maximum when the running clearance of bearing in normal running is slightly negative, but it is difficult to always hold this optimal condition during actual running. If the negative clearance value gets larger due to change of somewhat operating condition, it would cause significant reduction of bearing lifetime and overheat. To avoid such phenomena, generally proper initial radial clearance is selected and set up so the running clearance gets slightly larger than 0 (zero).

In the case of usual operating conditions, in other words, application of the fits based on ordinary load, usual rotational speed and running temperature, etc., an optimal running clearance can be got by selecting an ordinary clearance.

Table 5.1 Radial clearance in machined ring needle roller bearings
Table 5.1 (1) Interchangeable bearings

Unit μm

Nominal bore diameter d (mm)		Radial clearance							
		C2		Normal ❶		C3		C4	
over	incl.	min	max	min	max	min	max	min	max
—	10	0	30	10	40	25	55	35	65
10	18	0	30	10	40	25	55	35	65
18	24	0	30	10	40	25	55	35	65
24	30	0	30	10	45	30	65	40	70
30	40	0	35	15	50	35	70	45	80
40	50	5	40	20	55	40	75	55	90
50	65	5	45	20	65	45	90	65	105
65	80	5	55	25	75	55	105	75	125
80	100	10	60	30	80	65	115	90	140
100	120	10	65	35	90	80	135	105	160
120	140	10	75	40	105	90	155	115	180
140	160	15	80	50	115	100	165	130	195
160	180	20	85	60	125	110	175	150	215
180	200	25	95	65	135	125	195	165	235
200	225	30	105	75	150	140	215	180	255
225	250	40	115	90	165	155	230	205	280
250	280	45	125	100	180	175	255	230	310
280	315	50	135	110	195	195	280	255	340
315	355	55	145	125	215	215	305	280	370
355	400	65	160	140	235	245	340	320	415
400	450	70	190	155	275	270	390	355	465

❶ Supplementary suffix codes of clearance is not added to bearing numbers.

Table 5.1 (2) Non-interchangeable bearings

Unit μm

Nominal bore diameter d (mm)		Radial clearance							
		C2NA		NA ❷		C3NA		C4NA	
over	incl.	min	max	min	max	min	max	min	max
—	10	10	20	20	30	35	45	45	55
10	18	10	20	20	30	35	45	45	55
18	24	10	20	20	30	35	45	45	55
24	30	10	25	25	35	40	50	50	60
30	40	12	25	25	40	45	55	55	70
40	50	15	30	30	45	50	65	65	80
50	65	15	35	35	50	55	75	75	90
65	80	20	40	40	60	70	90	90	110
80	100	25	45	45	70	80	105	105	125
100	120	25	50	50	80	95	120	120	145
120	140	30	60	60	90	105	135	135	160
140	60	35	65	65	100	115	150	150	180
160	180	35	75	75	110	125	165	165	200
180	200	40	80	80	120	140	180	180	220
200	225	45	90	90	135	155	200	200	240
225	250	50	100	100	150	170	215	215	265
250	280	55	110	110	165	185	240	240	295
280	315	60	120	120	180	205	265	265	325
315	355	65	135	135	200	225	295	295	360
355	400	75	150	150	225	255	330	330	405
400	450	85	170	170	255	285	370	370	455

❷ For bearing with normal clearance, only NA is added to bearing numbers. EX. NA4920NA

5.2.2 Calculation of running clearance

The running clearance in bearing can be determined from initial radial clearance, reduced internal clearance incurred by effective interference, and temperature difference between inner ring and outer ring, using **formula (5.1)**.

$$\delta_{eff} = \delta_o - (\delta_f + \delta_t) \quad \text{.....(5.1)}$$

where,

- δ_{eff} : Running clearance mm
- δ_o : Initial radial clearance mm
- δ_f : Reduced internal clearance incurred by effective interference mm
- δ_t : Reduced internal clearance incurred by temperature difference between inner ring and outer ring mm

(1) Reduced internal clearance incurred by effective interference

When a bearing is installed on a shaft or in a housing with some effective interference, the inner ring expands and the outer ring shrinks and, as the result, the radial clearance in the bearing reduces correspondingly.

The expansion or shrinkage of inner ring or outer ring is approximately equivalent to 85% of the effective interference though depending on bearing type, shaft or housing profile, dimension and material. For the detail refer to **Table 6.4** on page A-35.

$$\delta_f = 0.85 \cdot \Delta_{deff} \quad \text{.....(5.2)}$$

where,

- δ_f : Reduced internal clearance incurred by effective interference mm
- Δ_{deff} : Effective interference mm

(2) Reduced internal clearance incurred by temperature difference between inner ring and outer ring

When a bearing is in running, the temperature of its outer ring is lower by 5 to 10°C than that of its inner ring or rolling elements. Also, temperature difference between the inner ring and the outer ring gets larger when heat is radiated more from the housing or when the bearing shaft is communicated with a heat source and a heated fluid is flowing through a hollowed shaft. In such a case, the internal clearance reduces corresponding to thermal expansion difference between the inner ring and the outer ring which is incurred by this temperature difference.

$$\delta_t = \alpha \cdot \Delta T \cdot D_o \quad \text{.....(5.3)}$$

where,

- δ_t : Reduced clearance value incurred by temperature difference mm
- α : Linear expansion coefficient of bearing steel $12.5 \times 10^{-6}/^\circ\text{C}$
- ΔT : Inner ring – outer ring temperature difference $^\circ\text{C}$
- D_o : Outer ring raceway diameter mm
- d : Bearing bore diameter mm
- D : Bearing outer diameter mm

When a shaft or a housing is used as a direct raceway, temperature difference between the shaft and the housing is applied as temperature difference (ΔT).

5.3 Fits and bearing radial clearance

Where the allowable tolerances for the shaft and the housing hole are already decided, the simple nomogram as shown in **Fig. 5.1** is available as a guideline to decision of the initial radial clearance of bearing so as to enable to get an optimal clearance after the bearing was installed on the shaft/in the housing. The nomogram in **Fig. 5.1** is used as the guideline as stated above. For the detail feel free to contact **NTN**.

For example, where the fit condition for needle roller bearing with inner ring is already given as J7m6, **Fig.5.1** shows that clearance C3 must be secured to get the standard running clearance after installation.

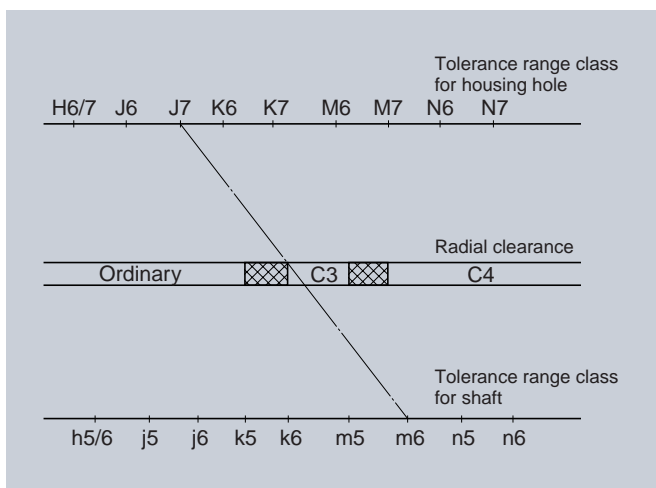

Fig. 5.1 Relationship between bearing fits and radial clearance

7. Bearing Fits

6.1 Interference

For rolling bearings, the inner ring and outer ring are fixed on the shaft or in the housing so that relative movement does not occur between the fitted surfaces of the bearing ring and the shaft or housing in radial, axial and rotational directions when a load acts on the bearing. Such a relative movement, if occurred, would result in wear, fretting corrosion, friction crack, etc. on the fitted surfaces, which would then cause damage of the bearing and the shaft or the housing. Furthermore, wear powder invades into the bearing, then causing imperfect rotation, abnormal overheat, vibration, etc.

The most effective way to fix a bearing is to assign an proper interference to the fitted surfaces between the bearing ring and the shaft or the housing and to thereby apply "tight fit" to the bearing. Furthermore, as its advantage this tight fit method supports the thin-walled bearing ring with uniform load throughout its entire circumference without any loss of load carrying capacity.

The needle roller bearing is a bearing type enabling to separate the inner ring and the outer ring from one another and, therefore, it can be installed on a shaft or in a housing with an interference applied to both of its inner ring and outer ring. In the case of "tight fit", the easiness of bearing installation and removal is lost and, therefore, the bearing ring subjected to stationary load can be "loose-fitted".

6.2 Necessity of proper fit

Improper fit could lead to damage and shorter life of bearing. Therefore, advance careful analysis is needed for selection of proper fit. Representative examples of bearing defects caused by improper fit are as described below.

- Crack and earlier separation of bearing ring, and displacement of bearing ring
- Wear of bearing ring, shaft and housing caused by creep and fretting corrosion
- Seizure (sticking) caused by less internal clearance
- Insufficient running accuracy and abnormal noise caused by deformed raceway surface

6.3 Fit selection

Fit selection is generally done in accordance with the rule specified hereunder.

The loads acting on each bearing ring are divided into running load, stationary load and directionally unstable load according to the direction and characteristic of loads acting on the bearing.

"Tight fit" can be selected for a bearing ring subjected to running load and directionally unstable load and "stationary fit" or "loose fit" be selected for a bearing ring subjected to stationary load. (See **Table 6.1**)

Where load of high magnitude or vibration and shock loads act on a bearing or a light alloy/plastic housing is used, it is necessary to secure a large interference. In that case, **however, the housing rigidity must be considered carefully so as not allow occurrence of split damage, etc.**

For an application subjected to high running accuracy, bearings of high accuracy must be used with a shaft and a housing of higher dimensional accuracy so as not to apply a large interference thereto. Applying a large interference would cause the shaft or housing profile to be transferred to the bearing track, which could then interfere with the bearing running accuracy. The said bearings of high accuracy are used to prevent such possible phenomena.

Table 6.1 Radial load and bearing fit

Bearing running conditions	Sketch	Load characteristic	Bearing fit	
			Inner ring	Outer ring
Inner ring : Rotation Outer ring: static Load direction: constant		Rotating inner ring load	Tight fit	Loose fit acceptable, too
Inner ring: static Outer ring: rotation Load direction: rotating with outer ring		Static outer ring load		
Inner ring: static Outer ring: rotation Load direction: constant		Rotating inner ring load	Loose fit acceptable, too	Tight fit
Inner ring: rotation Outer ring: static Load direction : rotating with inner ring		Static outer ring load		
Inner ring: rotation or static Outer ring: rotation or static Load direction: The direction can not be fixed.	Load direction is non-constant due to directional fluctuation, unbalanced load, etc.	Directionally unstable load	Tight fit	Tight fit

6.4 Recommended Fits

The dimensional tolerances for the diameter of a shaft and the hole diameter of a bearing housing, on/in which a bearing is installed, are standardized under the metric system in ISO 286 and JIS B 0401 (Dimensional Tolerances and Bearing Fits). Hence, bearing fits is determined by selection of the dimensional tolerances for shaft diameter and hole diameter as applicable. Fig. 6.1 shows the relationship between shaft diameter and bearing bore diameter and between housing hole

diameter and bearing outer diameter.

Table 6.2 shows the recommended fits for the machined ring needle roller bearings (with inner ring) that are generally selected based on the dimensional and load conditions. Table 6.3 shows the numerical fit values.

For the recommended fits for others than the machined ring needle roller bearings, refer to "Commentary" described in the respective Dimension Tables.

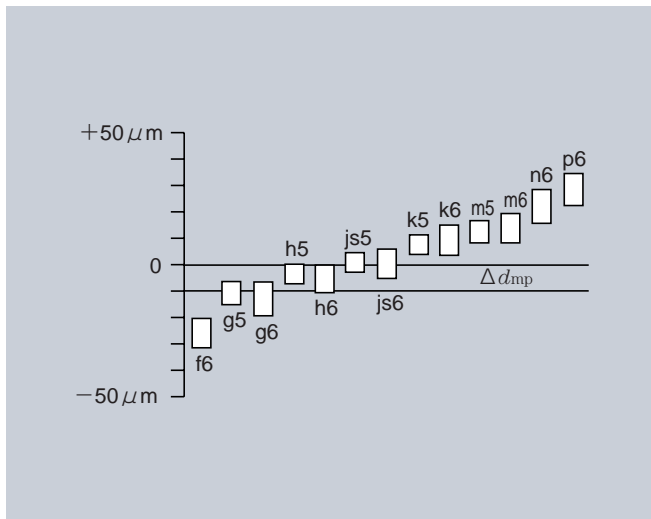

Fig. 6.1 (a) Bearing fits on shaft

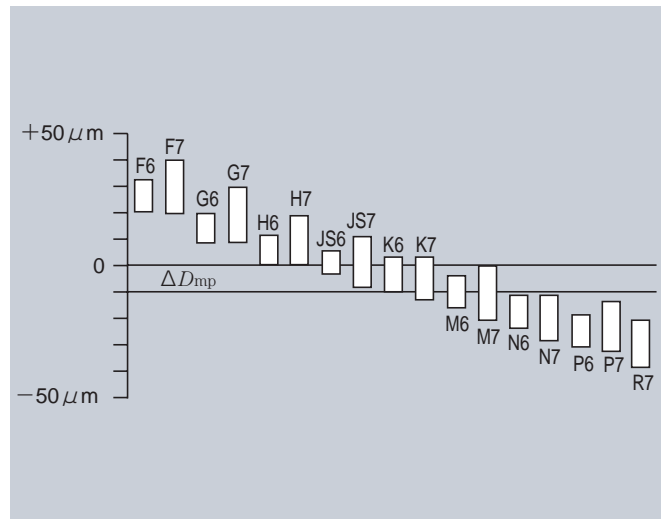

Fig.6.1(b) Bearing fits in housing hole

Table 6.2 Machined ring needle roller bearing fits

Table 6.2 (1) Dimensional tolerance for shaft diameter

Conditions			Tolerance range class
Load characteristic	Load magnitude	Shaft diameter <i>d</i> mm	
Rotating inner ring load or directionally unstable load	Light load	~ 50	j5
	Ordinary load	~ 50	k5
		50~150	m5
		150~	m6
	Heavy load and shock load	~150	m6
150~		n6	
Inner ring static load	Medium- and low-speed rotation, light load	All dimensions	g6
	General application		h6
	When high rotational accuracy is required		h5

Table 6.2 (2) Dimensional tolerances for housing

Conditions		Tolerance range class
Outer ring static load	Rotating outer ring load	
Outer ring static load	Ordinary and heavy load	J7
	Two-split housing, ordinary load	H7
Rotating outer ring load	Light load	M7
	Ordinary load	N7
	Heavy load and shock load	P7
Directionally unstable load	Light load	J7
	Ordinary load	K7
	Heavy load and shock load	M7
When high rotational accuracy under light load is required		K6

Remarks: Light load, ordinary load and heavy load are classified per the following criteria.

- Light load : $P_r \leq 0.06C_r$
- Ordinary load : $0.06C_r < P_r \leq 0.12C_r$
- Heavy load : $P_r > 0.12C_r$

Table 6.3 Numerical fit values for radial bearing (JIS Class-0)
Table 6.3(1) Bearing fits on shaft

Unit μm

Nominal bore diameter d mm	Allowable deviation of mean bore diameter Δd_{mp}	g6		h5		h6		j5		k5		m5		m6		n6			
		Bearing	Shaft	Bearing	Shaft	Bearing	Shaft	Bearing	Shaft	Bearing	Shaft	Bearing	Shaft	Bearing	Shaft	Bearing	Shaft		
pver	incl.	high	low																
3	6	0	-8	4T~12L		8T~5L		8T~8L		11T~2L		14T~1T		17T~4T		20T~4T		24T~8T	
6	10	0	-8	3T~14L		8T~6L		8T~9L		12T~2L		15T~1T		20T~6T		23T~6T		27T~10T	
10	18	0	-8	2T~17L		8T~8L		8T~11L		13T~3L		17T~1T		23T~7T		26T~7T		31T~12T	
18	30	0	-10	3T~20L		10T~9L		10T~13L		15T~4L		21T~2T		27T~8T		31T~8T		38T~15T	
30	50	0	-12	3T~25L		12T~11L		12T~16L		18T~5L		25T~2T		32T~9T		37T~9T		45T~17T	
50	80	0	-15	5T~29L		15T~13L		15T~19L		21T~7L		30T~2T		39T~11T		45T~11T		54T~20T	
80	120	0	-20	8T~34L		20T~15L		20T~22L		26T~9L		38T~3T		48T~13T		55T~13T		65T~23T	
120	140	0	-25	11T~39L		25T~18L		25T~25L		32T~11L		46T~3T		58T~15T		65T~15T		77T~27T	
140	160																		
160	180																		
180	200	0	-30	15T~44L		30T~20L		30T~29L		37T~13L		54T~4T		67T~17T		76T~17T		90T~31T	
200	225																		
225	250																		
250	280	0	-35	18T~49L		35T~23L		35T~32L		42T~16L		62T~4T		78T~20T		87T~20T		101T~34T	
280	315																		
315	355																		
355	400	0	-40	22T~54L		40T~25L		40T~36L		47T~18L		69T~4T		86T~21T		97T~21T		113T~37T	
400	450																		
450	500																		

Table 6.3 (2) Bearing fits in housing hole

Unit μm

Nominal outer diameter D mm	Allowable deviation of mean outer diameter ΔD_{mp}	H7		J7		K6		K7		M7		N7		P7			
		Housing	Bearing	Housing	Bearing	Housing	Bearing	Housing	Bearing	Housing	Bearing	Housing	Bearing	Housing	Bearing		
over	incl.	high	low														
6	10	0	-8	0~23L		7T~16L		7T~10L		10T~13L		15T~8L		19T~4L		24T~1L	
10	18	0	-8	0~26L		8T~18L		9T~10L		12T~14L		18T~8L		23T~3L		29T~3L	
18	30	0	-9	0~30L		9T~21L		11T~11L		15T~15L		21T~9L		28T~2L		35T~5L	
30	50	0	-11	0~36L		11T~25L		13T~14L		18T~18L		25T~11L		33T~3L		42T~6L	
50	80	0	-13	0~43L		12T~31L		15T~17L		21T~22L		30T~13L		39T~4L		52T~8L	
80	120	0	-15	0~50L		13T~37L		18T~19L		25T~25L		35T~15L		45T~5L		59T~9L	
120	150	0	-18	0~58L		14T~44L		21T~22L		28T~30L		40T~18L		52T~6L		68T~10L	
150	180	0	-25	0~65L		14T~51L		21T~29L		28T~37L		40T~25L		52T~13L		68T~3L	
180	250	0	-30	0~76L		16T~60L		24T~35L		33T~43L		46T~30L		60T~16L		79T~3L	
250	315	0	-35	0~87L		16T~71L		27T~40L		36T~51L		52T~35L		66T~21L		88T~1L	
315	400	0	-40	0~97L		18T~79L		29T~47L		40T~57L		57T~40L		73T~24L		98T~1L	
400	500	0	-45	0~108L		20T~88L		32T~53L		45T~63L		63T~45L		80T~28L		108T~0	

Remarks: Fit symbols "L" and "T" represent bearing clearance and interference respectively.

6.5 Interference Calculation

(1) Load and required interference

When radial load acts on a bearing, the interference required to prevent a clearance between its inner ring and a steel solid shaft can be expressed in **formulas (6.1)** and **(6.2)**.

For $F_r \leq 0.3 C_{or}$,

$$\Delta d_F = 0.08 \sqrt{\frac{d \cdot F_r}{B}} \left(0.25 \sqrt{\frac{d \cdot F_r}{B}} \right) \dots\dots\dots (6.1)$$

For $F_r > 0.3 C_{or}$,

$$\Delta d_F = 0.02 \frac{F_r}{B} \left(0.2 \frac{F_r}{B} \right) \dots\dots\dots (6.2)$$

Where,

- Δd_F : Required effective interference mm
- d : Bearing bore diameter mm
- B : Inner ring width mm
- F_r : Radial load N (kgf)
- C_{or} : Basic static load rating N (kgf)

(2) Temperature rise and required interference

When temperature rise of bearing (difference between bearing temperature and ambient temperature) is inevitable incurred by bearing running, the interference required to prevent a clearance between the inner ring and a steel shaft can be expressed in **formula (6.3)**.

$$\Delta d_F = 0.0015 \cdot d \cdot \Delta T \dots\dots\dots (6.3)$$

Where,

- Δd_T : Required effective interference for temperature difference μm
- ΔT : Difference between bearing temperature and ambient temperature $^{\circ}C$
- d : Bearing bore diameter mm

(3) Fitting surface roughness and required interference

The fitting surface is smoothed (surface roughness is made less) by bearing fits so that the interference reduces correspondingly. The interference reduced value differs depending on the fitting surface roughness and generally the following reduction values must be prospected.

- For ground shafts : 1.0 to 2.5mm
- For lathe-turned shafts : 5.0 to 7.0 mm

(4) Maximum interference

Bearing ring fitted, with interference, on a shaft or in a housing results in tensile stress or compressive stress. Over-interference could cause cracking /splitting of bearing and short fatigue life of bearing. Therefore, in general the maximum interference is secured at 1/1000 and less of shaft diameter or otherwise it is secured so the circumferential maximum stress generating on the fitting surface comes to 130MPa or less. (See **Table 6.4**)

(5) Stress and deformation caused by interference

When bearing ring (solid) is fitted with interference, it deforms elastically and this elastic deformation results in stress.(See **Fig.6.2**) The fitting surface pressure of bearing ring, circumferential tensile stress (inner ring), compressive stress (outer ring) and radial expansion of raceway (inner ring), and shrinkage(outer ring) can be calculated from **Table 6.4**.

Table 6.4 Deformation and stress caused by bearing fit

Item	Inner ring	Outer ring
Surface pressure p MPa	$p_i = \frac{E}{2} \frac{\Delta d_{eff}}{d} \frac{(1-k^2)(1-k_o^2)}{1-k^2k_o^2}$	$p_e = \frac{E}{2} \frac{\Delta D_{eff}}{D} \frac{(1-h^2)(1-h_o^2)}{1-h^2h_o^2}$
Circumferential maximum stress σ MPa	$\sigma_i = p_i \frac{1+k^2}{1-k^2}$ (Tensile stress)	$\sigma_e = p_e \frac{2}{1-h^2}$ (Compressive stress)
Radial elastic deformation of raceway Δ	$\Delta_i = \Delta d_{eff} \cdot k \frac{1-k_o^2}{1-k^2k_o^2}$ (Expansion)	$\Delta_e = \Delta D_{eff} \cdot h \frac{1-h_o^2}{1-h^2h_o^2}$ (Shrinkage)

Where,

$$k = \frac{d}{d_i}, k_o = \frac{d_o}{d}, h = \frac{D_e}{D}, h_o = \frac{D}{D_o}$$

Remarks (Symbol representation)

- d : Inner ring bore diameter (shaft diameter) mm
- d_o : Hollowed shaft bore diameter (For solid shaft, $d_o=0$) mm
- d_i : Inner ring raceway diameter mm
- Δd_{eff} : Effective interference for inner ring mm
- D : Outer ring outer diameter (housing hole diameter) mm
- D_o : Housing outer diameter (For sufficient housing size, $D_o=\infty$) mm
- D_e : Outer ring raceway diameter mm
- ΔD_{eff} : Effective interference for outer ring mm
- E : Modulus of elasticity (Young factor) 2.07×10^5 (21200) MPa (kgf/mm²)

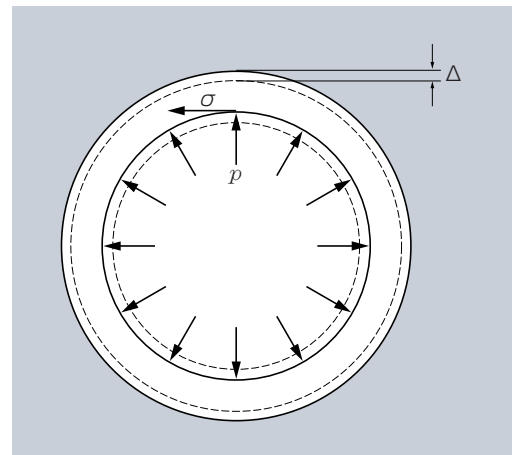

Fig.6.2

7. Shaft and Housing Design

Even if the bearing to be used is selected correctly, it can not fulfill its specific function unless the shaft/housing on/in which it is installed is designed correctly. Particularly for needle roller bearings the shaft and the housing must be designed under special consideration because the bearing ring thickness is thinner than that of other rolling bearings.

7.1 Design of bearing installing portions

Where a needle roller bearing with cage is used as an individual and is guided in axial direction directly by shaft shoulder (**Fig.7.1**), the shaft shoulder with which the cage side face comes in contact must be finished accurately and also is not allowed to have any raiser thereon. For a needle roller bearing subjected to high speed running, its contact surface is hardened and thereafter fine-finished by grinding.

When a snap ring is used for axial guide of the cage (**Fig.7.1**), a thrust ring is inserted between the cage and the snap ring to prevent the cut section of the snap ring from contacting directly the cage. NTN shaft snap ring WR type specially designed for NTN needle roller bearings is available as the snap ring intended for axial guide of bearing cage. (Refer to Dimensions Table on page B-227.)

On other hand, radial needle roller bearing can move freely in axial direction so that a ball bearing or a thrust bearing is used at single side for axial positioning of the shaft. Where axial load is less and, in addition, rotational speed is not so high (Ex. idle gear in a gear box), a thrust ring is fitted on the shaft, as illustrated in **Fig. 7.2** and a sliding bearing is formed between the thrust ring and the outer ring or the housing end face for the purpose of axial positioning. In such a design, good care must be exercised so the guide surface is fully lubricated. **Fig.7.3** illustrates an example of the above thrust ring with oil groove on its guide surface. The boundary between this oil groove and the plane area must be chamfered for deburring.

In general, for proper installation of needle roller bearing the inner ring and outer ring are both positioned in axial direction so that the bearing displaces in axial direction while running.

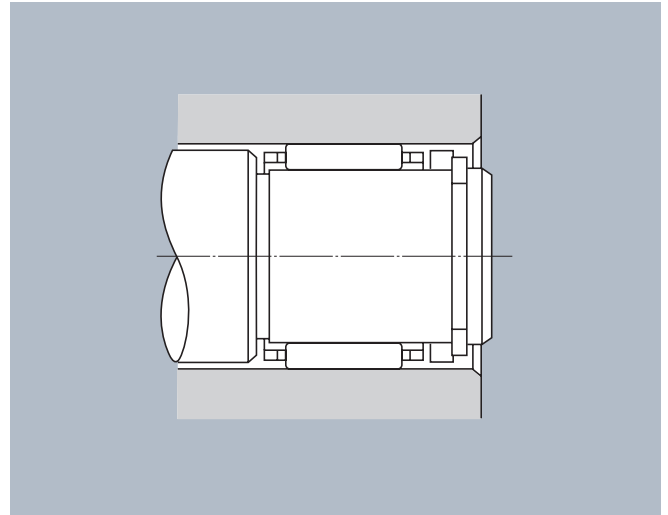

Fig. 7.1 Bearing fixing by thrust ring

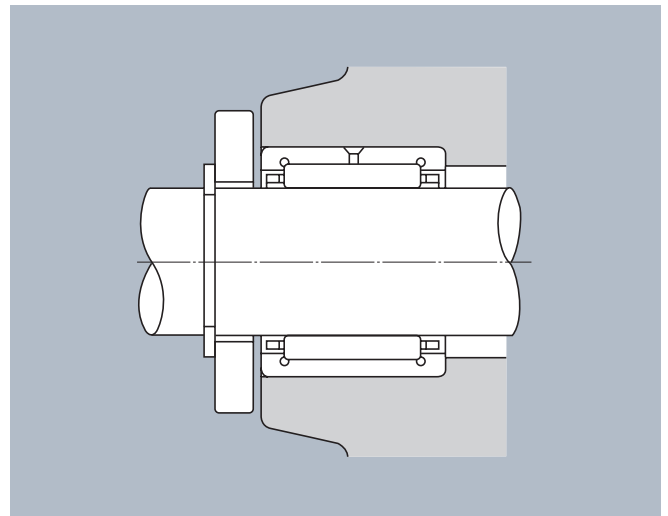

Fig. 7.2 Bearing fixing in axial direction

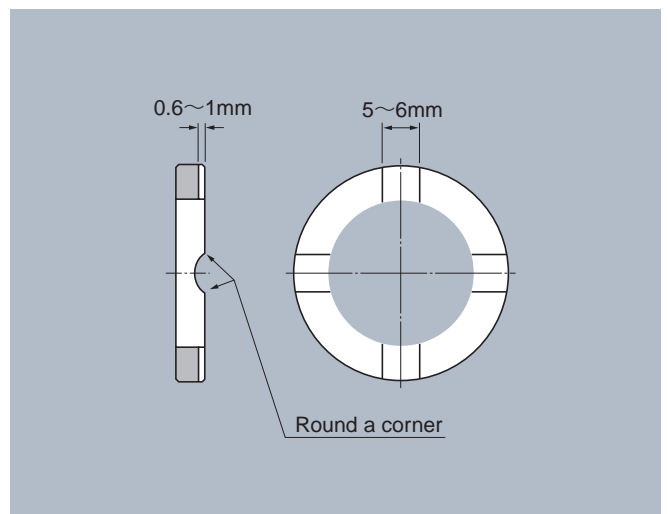

Fig. 7.3 Design of thrust ring guide surface

(1) Inner ring

For fixing inner ring correctly on a shaft, the shaft shoulder face is finished at the right angle against the shaft axial center and, in addition, the shaft corner is rounded smaller than the inner ring chamfer dimension.

Where the corner roundness $r_a \text{ max}$ must be made larger for specific shaft strength (**Fig.7.4a**) or the shaft shoulder is low (**Fig. 7.4b**), a spacer must be inserted between the shaft shoulder and the inner ring to hold a full contact surface with the inner ring. Furthermore, for facilitating inner ring pull-out work the shaft shoulder is provided with a notched groove, as illustrated in **Fig. 7.5**, to accept an inner ring pull-out jig (puller).

NTN snap ring WR type for shaft use (Refer to Dimensions Table on page B-227) can be used for simply fixing inner ring in axial direction. (**Fig. 7.6**) Moreover, inner ring can be fixed in axial direction using an end plate or a side ring as illustrated in **Figs. 7.7** and **7.8**.

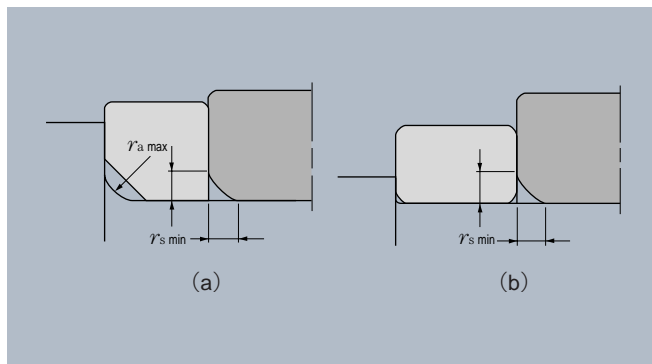

Fig. 7.4 Inner ring fixing by use of spacer

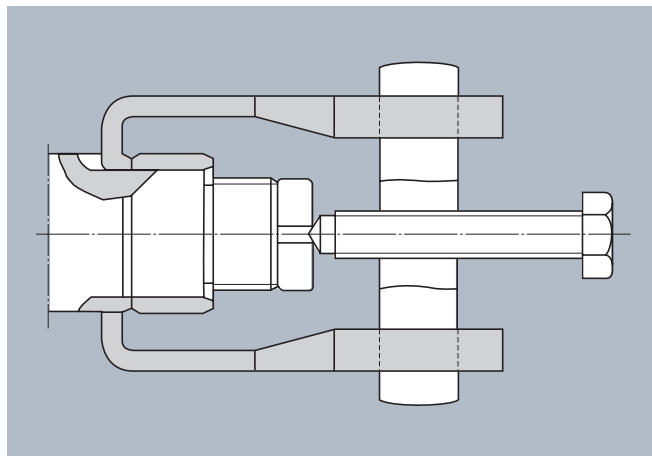

Fig. 7.5 Inner ring pull-out jig (puller)

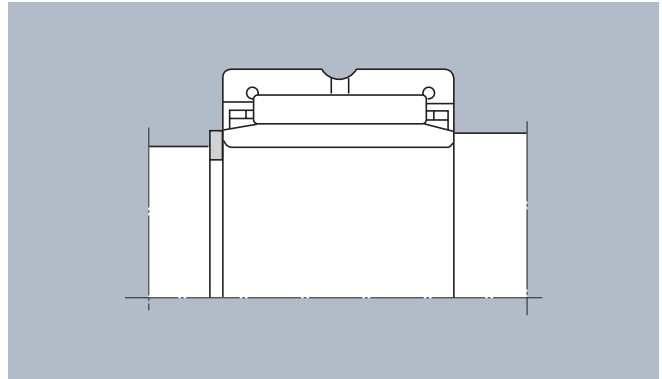

Fig. 7.6 Inner ring fixing by snap ring

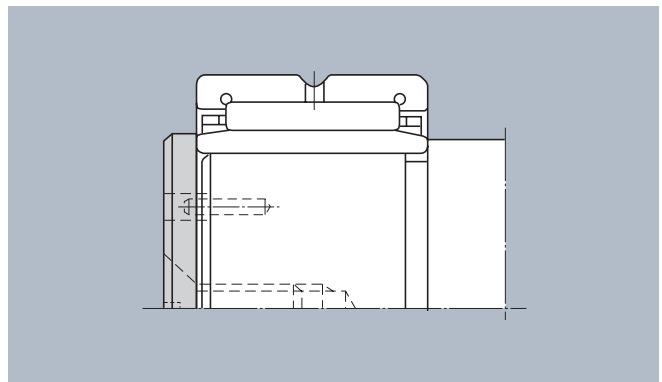

Fig. 7.7 Inner ring fixing by end plate

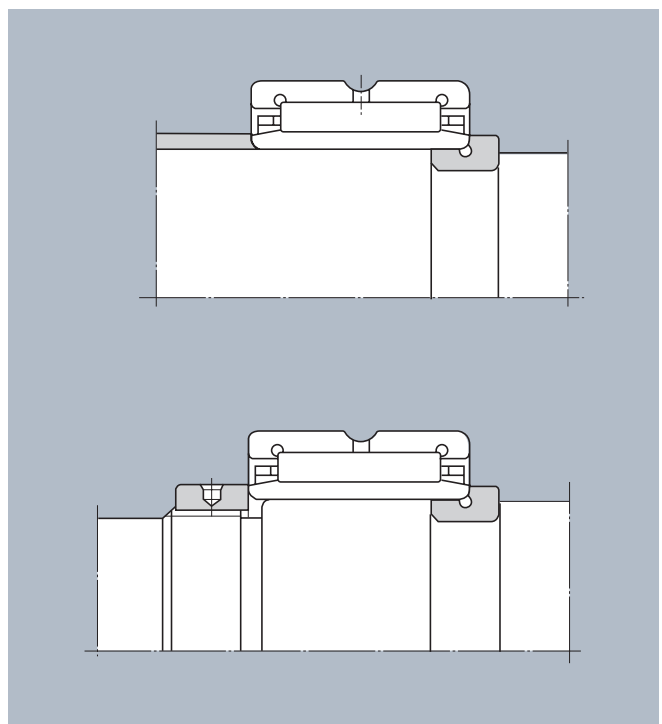

Fig. 7.8 Inner ring fixing by side ring

(2) Outer ring

Similarly to Para. 7.1(1) "Inner Ring", good care exercised of the shoulder profile of bearing housing for fixing outer ring in axial direction.

Figs. 7.9 and 7.10 illustrate the methods of fixing outer ring in axial direction.

NTN housing snap ring BR type (Refer to Dimensions Table on page B-229) can be used for fixing outer ring in axial direction. NTN BR type snap rings are designed to the dimensions adaptable to the needle roller bearings with low section height. However, commercially available snap rings conforming to JIS standard as applicable can also be used for the same bearings with adequately high section height.

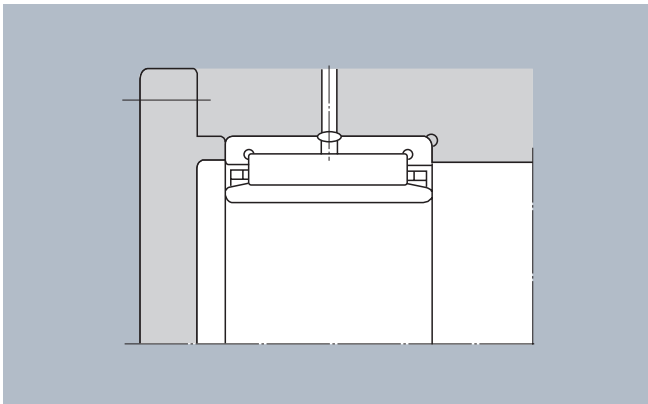

Fig. 7.9 Outer ring fixing by lid

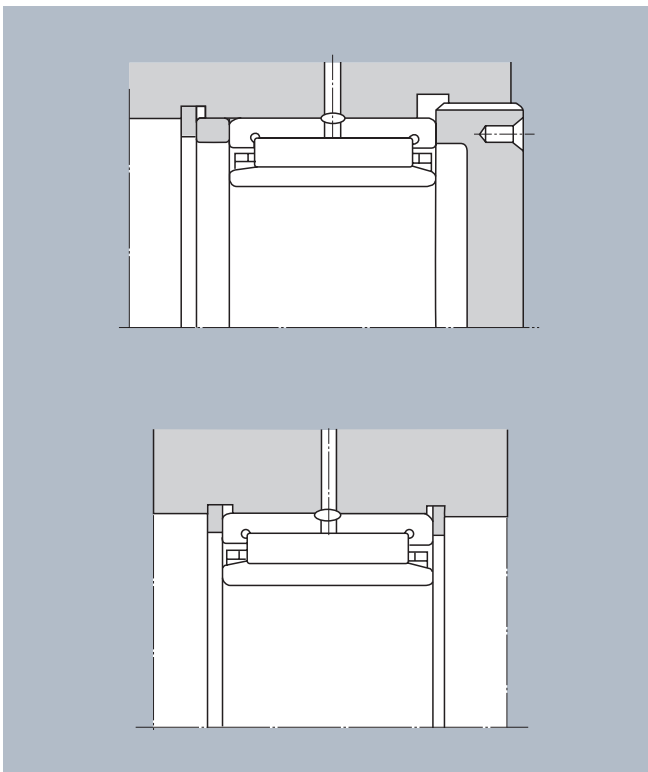

Fig. 7.10 Outer ring fixing by snap ring

7.2 Bearing fitting dimensions

The respective shoulder heights " h " of shaft and housing are designed larger than the maximum chamfer dimension $r_{s \text{ max}}$ for bearing so the bearing end face comes in contact with the flat zone. And the corner roundness " r_{as} " is designed smaller than the minimum chamfer dimension " r_s " of bearing so as not to interfere with the bearing. Generally the radius of shaft and housing corner roundness shown in **Table 7.1** is used as the shoulder heights of shaft and housing.

The dimensions of the shafts and housings related to bearing installation are as described in the dimensions table for each bearing type. The shoulder diameter shown in this table means the effective shoulder diameter which comes in contact with the side face of bearing excluding the chamfered portion of shoulder.

When the fitting surface of shaft or housing is finished by grinding, the shoulder corner must be provided with a relief. This relief dimension is as shown in **Table 7.2**.

Table 7.1 Radius of shaft /housing corner roundness and shoulder height

Unit mm		
$r_s \text{ min}$	$r_{as \text{ max}}$	$h \text{ (min)}$
0.15	0.15	0.6
0.2	0.2	0.8
0.3	0.3	1
0.6	0.6	2
1	1	2.5
1.1	1	3.25
1.5	1.5	4
2	2	4.5
2.1	2	5.5
2.5	2	6
3	2.5	6.5
4	3	8

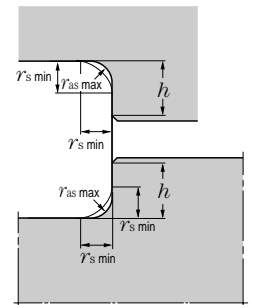
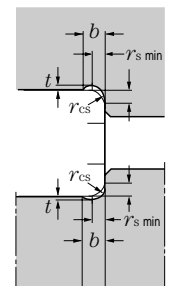

Table 7.2 Relief grinding dimension for shaft and housing corners

Unit mm			
$r_s \text{ min}$	b	t	r_{cs}
1	2	0.2	1.3
1.1	2.4	0.3	1.5
1.5	3.2	0.4	2
2	4	0.5	2.5
2.1	4	0.5	2.5
3	3.7	0.5	3
4	5.9	0.5	4



7.3 Shaft and housing accuracy

Because of its thin wall, the raceway surface accuracy of needle roller bearing ring is influenced by the respective fitting surface accuracy of a shaft /a housing on/in which the needle roller bearing is installed. In the case of general operating conditions, the fitting surfaces of shaft and housing may be finished by lathe-turning, but those must be finished by grinding where the acting load is great and, in addition, the requirements for accuracy and sound are strict.

Table 7.3 shows the fitting surface accuracy, profile accuracy, surface roughness, and shoulder perpendicularity to fitting surface of each of shaft and housing under ordinary operating conditions.

Table 7.3 Shaft and housing accuracy

Characteristic item	Shaft	Housing
Dimensional accuracy	IT6 (IT5)	IT7 (IT6)
Roundness cylindricality (max)	IT3 (IT2)	IT4 (IT3)
Shoulder perpendicularity (max)	IT5 (IT4)	IT5 (IT4)
Fitting surface roughness	0.8a	1.6a

Remarks: The parenthesized values are applied to the bearings of accuracy class 5 and higher.

Where a two-split housing is used, deformation of outer ring by housing clamping can be minimized by providing a relief on the mating surface at bore side.

7.4 Raceway surface accuracy

For needle roller bearings, shaft and housing are used as the raceway surface on application. The raceway dimensional accuracy, profile accuracy and surface roughness of shaft/housing must be equivalent to the raceway accuracy of bearing itself. **Table 7.4** shows the specified surface accuracy and surface roughness of shaft/housing raceway.

Table 7.4 Raceway surface accuracy (recommendation)

Characteristic item	Shaft	Housing
Dimensional accuracy	IT5 (IT4)	IT6 (IT5)
Roundness cylindricality (max)	IT3 (IT2)	IT4 (IT3)
Shoulder perpendicularity (max)	IT3 (IT2)	IT3 (IT2)
Axial run-out Thrust bearing (max)	IT5 (IT4)	
Surface roughness	For shaft diameter of ϕ 80 and less :0.2a For shaft diameter of over ϕ 80 to 120 :0.3a For shaft diameter of over ϕ 120 :0.4a	

Note) The parenthesized values are applied where high rotational accuracy is required.

7.5 Material and hardness of raceway surface

When the outer surface or bore surface of shaft(hollowed) or housing is used as raceway, it must be hardened to HRC58 to 64 for getting sufficient load capacity. For that, the materials shown in **Table 7.5** are used after heat-treated properly.

Table 7.5 Materials used for raceway

Kinds of steel	Representative example	Related standards
High carbon chrome bearing steel	SUJ2	JIS G 4805
Carbon tool steel	SK3	JIS G 4401
Nickel chrome molybdenum steel	SNCM420	JIS G 4103
Chrome steel	SCr420	JIS G 4104
Chrome molybdenum steel	SCM420	JIS G 4105
Nickel chrome steel	SNC420	JIS G 4102

When steel is surface-hardened by carburizing or carbonitriding, JIS Standard as applicable defines the depth from surface up to HV550 as an effective hardened layer. The minimum value of effective hardened layer depth is approximately expressed in **formula (7.1)**.

$$E_{ht \min} \geq 0.8D_w (0.1+0.002D_w) \dots\dots\dots(7.1)$$

Where,

$E_{ht \min}$: Minimum effective hardened layer depth mm

D_w : Roller diameter mm

7.6 Allowable bearing inclination

The inner ring and outer ring of bearing incline a little eventually against one another depending on shaft deflection, shaft /housing machining accuracy, fitting deviation, etc. Although this allowable inclination differs depending on bearing type, bearing load, internal clearance, etc., the inclination degree shown in **Table 7.6** must be used as a guideline in the case of general applications because even minor inclination of inner ring and outer ring could cause reduction of bearing life and damage of cage.

Table 7.6

Bearing type	Allowable inclination
Radial needle roller bearing	1/2 000
Thrust bearing	1/10 000

8. Lubrication

The purpose of lubricating bearings is to form a thin oil film on the rolling and sliding surfaces and to thereby prevent metal to metal direct contact. Furthermore, lubricating rolling bearings has the following effects.

- (1) Reduction of friction and wear
- (2) Discharge of friction heat
- (3) Further extension of bearing life
- (4) Rusting prevention
- (5) Prevention of foreign matter invasion

For achieving these lubrication effects it is necessary to select a good quality lubricant, to remove dust from the lubricant, and to design a proper seal structure for prevention of lubricant leak as well as to adopt the lubrication method suitable to the respective actual operating conditions.

Rolling bearings are mostly lubricated with grease or oil, but solid lubricants such as molybdenum disulfide, graphite, etc. are used for special application.

Further, the comparative data of grease lubrication and oil lubrication given in **Table 8.1** can be utilized as the selection guide.

Table 8.1 Characteristic comparison of grease lubrication with oil lubrication

Lubrication method Comparative items	Grease lubrication	Oil lubrication
Handling	◎	△
Reliability	○	◎
Cooling effect	×	○ (Recirculation needed)
Seal structure	○	△
Power loss	○	○
Environmental pollution	○	△
High speed running of bearing	×	○

◎ : Extraordinarily advantageous ○ : Advantageous
 △ : Fairly advantageous × : Disadvantageous

8.1 Grease lubrication

Grease lubrication is the simplest lubrication method. This method enabling to simplify design of the seal structure is broadly used.

Important points in this lubrication method are to select an optimum grease and to fill it securely in a bearing. Particularly where the cage is guided by the inner ring or outer ring of bearing, good care must be exercised so the guide surface is fully greased throughout its entire area.

Furthermore, for grease replenishment it is desirable to provide a grease sector and a grease valve, etc. as a grease replenisher. **Fig. 8.1** illustrates an example of bearing unit with grease sector and grease valve.

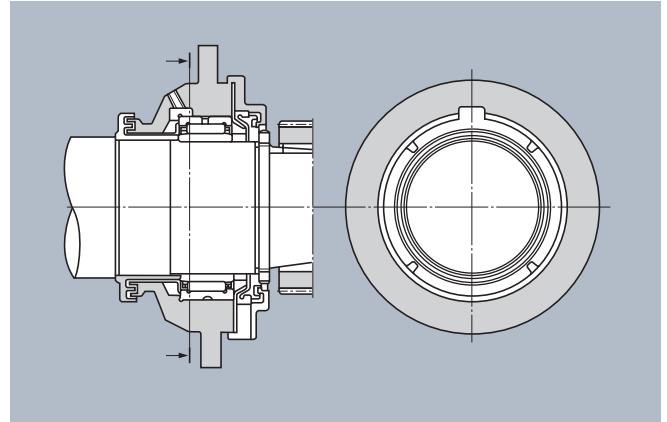

Fig. 8.1 An example of bearing unit with grease sector and grease valve

8.1.1 Types and characteristics of grease

Lubrication oil is composed of a lubrication base oil (ex. mineral oil base or a synthetic oil base) held with a thickener and various additives added thereto. The properties of grease is determined by the kinds and combination of base oil, thickener and additives.

Table 8.2 shows the general types of grease and their characteristics. Even the grease of same type is significantly different in the performance depending on the grease brand selected. In selecting a grease brand, therefore, it is necessary to verify the property data submitted from the grease manufacturer.

8.1.2 Base oil

Mineral oil or synthetic oils such as diester oil, and synthetic oil such as silicone oil, fluorocarbon oil, etc. are used as the base oil for grease.

The lubrication performance of grease is mainly determined by the lubrication performance of the base oil. In general, a grease composed of low viscosity base oil is excellent in low temperature characteristic and high speed performance and, on the other hand, a grease composed of high viscosity base oil is excellent in high load characteristic.

8.1.3 Thickener

Thickener is blended and diffused in base oil to hold grease in semi-solid form. And various thickeners are available for use as follows; thickener composed of metallic soap such as lithium, sodium or calcium, etc., thickener composed of inorganic material such as silica gel, bentonite, etc., and non-soap base thickener composed of organic material such as polyurea, fluorocarbon, etc.

The grease characteristics such as critical operating temperature, mechanical stability, durability, etc. are mainly determined by the kind of thickener used. In general, the sodium soap base grease is inferior to others in water resistance. Non-metallic soap base thickener composed of bentone, polyurea, etc. is excellent in high temperature characteristic.

Table 8.2 Grease varieties and characteristics

Grease name	Lithium grease			Sodium grease (Fiber grease)	Calcium compound base grease	Aluminum grease	Non-soap grease	
Thickener	Li soap			Na soap	Ca+Na soap Ca+Li soap	Al soap	Bentone, silica gel, urea, carbon black, etc.	
Base oil	Mineral oil	Diester oil	Silicone oil	Mineral oil	Mineral oil	Mineral oil	Mineral oil	Synthetic oil
Dropping point °C	170~190	170~190	200~250	150~180	150~180	70~90	250 or more	250 or more
Operating temperature range °C	-30~+130	-50~+130	-50~+160	-20~+130	-20~+120	-10~+80	-10~+130	-50~+200
Mechanical stability	Excellent	Good	Good	Excellent to good	Excellent to good	Good to poor	Good	Good
Pressure resistance	Good	Good	Poor	Good	Excellent to good	Good	Good	Good
Water resistance	Good	Good	Good	Good to poor	Good to poor	Good	Good	Good
Applications	Broadest application. Grease for universal type rolling bearings.	Excellent in low temperature characteristic and anti-friction characteristic.	suited to high temperature and low temperature. Low oil film strength and unsuitable for high load application.	emulsified by inclusion of water content. Comparatively excellent in high temperature characteristic.	Excellent in water resistance and mechanical stability. Suitable for bearing subjected to shock load.	Excellent in viscosity characteristic. Suitable for bearing subjected to vibration.	Available for use in wide temperature range from low to high temperature. Some of non-soap base greases are excellent in heat resistance, cold resistance, chemical resistance, etc. subject to proper combination of base oil and thickener. Grease for universal type rolling bearings.	

Remarks: The operating temperature range in this table is the general characteristic value, not the guaranteed value.

8.1.4 Additives

Any greases contain various additives to improve the performance, for example, containing oxidation inhibitor, extreme pressure additives (EP additives), rust inhibitor, corrosion inhibitor, etc.

A grease containing extreme pressure additives is used for bearings subjected to high load or shock load. A grease containing oxidation stabilizer is used for bearing applications wherein the operating temperature is comparatively high and no grease is replenished for a long time.

8.1.5 Consistency

"Consistency" is an index showing the hardness or fluidity of grease. The greater numerical value thereof is the softer hardness. This consistency is determined by the amount of thickener and the viscosity of base oil. Usually NLGI consistency codes 1 and 2 or 3 are used for lubrication of bearings.

Table 8.3 shows the general relationship of grease consistency to application.

8.1.6 Grease mixing

When different greases are mixed together, the consistency of the mixed grease varies (generally softens) so that the allowable operating temperature gets lower. To avoid such characteristic variation of grease, it is not allowed to mix different greases, except mixing greases of same brand.

Where mixing of different greases is inevitable, greases composed of thickener of same kind and similar base oil must be selected. Even when greases of same kind are mixed together, thus, the properties of the mixed grease could vary depending on difference in additives, etc. It is therefore necessary to check the property variation in advance.

Table 8.3 Grease consistency

NLGI consistency No.		JIS (ASTM) 60-cycle mixed grease consistency	Application
0	Soft	355~385	For centralized greasing
1	↑ ↓	310~340	For centralized greasing
2		265~295	For general application, for tight-sealed bearing
3		220~250	For general application, for high temperature
4	Hard	175~205	Special application

8.1.7 Grease fill amount

Grease fill amount differs depending on housing design, spacing volume, rotational speed, kind of grease, etc.

Around 50% to 80% of static spacing volume in bearing and housing is deemed as a guideline to the fill amount. In the case of high rotational speed, this fill amount must be set up a little bit less for controlling temperature rise to a low rate. **Too much fill amount of grease would cause the grease temperature to rise higher, which would then lead to reduction of the specific lubrication performance due to leak of the softened grease or quality change such as oxidation, etc.**

Further, for the machined ring needle roller bearing with inner ring the approximate value of spacing volume in the bearing can be determined by formula (8.1).

$$V = 35W \dots\dots\dots(8.1)$$

where,

V : Internal spacing volume (approximate value) cm³
 W : Bearing weight kg (See Dimensions Table)

8.1.8 Grease replenishment

Lubrication grease must be replenished at an proper interval because its lubrication performance deteriorates with elapse of the bearing running time. However, this replenishing interval differs depending on bearing type, dimension, rotational speed, bearing temperature, kind of grease used, etc.

Fig.8.2 gives the replenishing interval chart as a guideline. This chart is subject to use of a grease for ordinary rolling bearings under usual operating conditions.

Needless to say, the grease replenishing interval must be the shorter as the bearing temperature gets higher. As an approximate guideline, when the bearing temperature is 80°C or more, the replenishing interval shall be shortened by 1/1.5 whenever the bearing temperature rises by 10°C.

[Ex.] Determine the grease replenishing interval in the case when bearing **NA4910R** is in running under the conditions of radial load P_r 5kN {510kgf} and rotational speed n 1 600r/min.

$d = 50\text{mm}$,

$n_o = 4700$ is determined from NA4910R

$C_r = 48\text{kN}$ (4900kgf) and allowable rotational speed = 4,700 r/min in the Dimensions Table.

Accordingly,

$$\frac{n_o}{n} = \frac{4700}{1600} \doteq 2.9$$

Plot a line horizontally from $d = 50$ point in Fig. 8.2 and

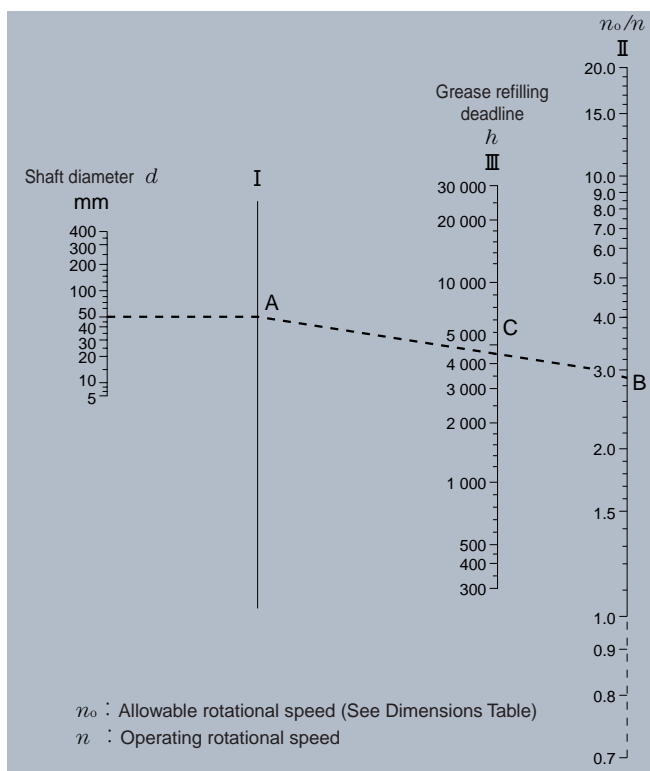

Fig.8.2 Chart for determination of grease replenishing interval

deem the intersection point with the vertical line I as A. Thereafter, connect $n_o/n=3$ point B on the vertical line II and said A point together, with a straight line, and determine the intersection point C with the vertical line III. And the grease replenishing interval of approximately 4600 hours can be read from the intersection point C.

8.2 Oil lubrication

In general, oil lubrication is more suitable for high speed running application or high temperature application than grease lubrication. Oil lubrication is suitable for the case where heat value generating from a bearing or heat value being transferred to a bearing must be discharged outside the bearing.

8.2.1 Lubrication method

(1) Oil bath lubrication

This oil bath lubrication is the most common of the currently available oil lubrication methods, which is applied to bearings running at low or medium speed. An important point in this method is control of oil level in an oil bath.

For that, when bearings are installed on a horizontal shaft, it is common that a point close to the center of the rolling element in the lowest position should be deemed as the oil level to be secured during shutdown. In this case, the housing must be designed in such a profile as to minimize variation in oil level therein. Furthermore, it is desirable to provide the housing with an oil gauge to facilitate level check during running as well as shutdown.

When bearings are installed on a vertical shaft, it is okay if 50 to 80% of the rolling elements are dipped in an oil bath under low speed running, but in the cases of high speed running and bearings used in multiple rows it is desirable to adopt the drip lubrication and circulating lubrication methods, and others described hereunder.

(2) Spray lubrication

This method sprays lubrication oil by an impeller of simple structure, which is mounted on the shaft, without directly dipping a bearing in an oil batch. This can be applied to bearings running at considerably high speed.

(3) Drip lubrication

This lubrication method is used where bearing runs at comparatively high speed and medium and less loads act on thereon. In this method, oil drips from an oiler provided on the top of a bearing unit strikes the rolling elements in its housing for atomizing lubrication (Fig. 8.3) or otherwise a small amount of oil passes through the bearing. In many cases bearing is lubricated with several drips per minute though the number of oil drips per specific unit differs depending on bearing type and dimension.

(4) Circulating lubrication

This circulating lubrication method is adopted to cool down bearings or to lubricate automatically many lubricating portions by a centralized lubrication system. In more detail, as the features of this method the oil feed line is equipped with a cooler to cool down the lubrication oil and, in addition, provided with an oil filter to purify the lubrication oil.

Under this circulating lubrication system, the lubrication oil must securely be discharged from each bearing after having passed through it. For that, it is important to provide an oil inlet and an oil outlet on each bearing in opposite position and to make the oil discharge port size as large as possible or otherwise to discharge the oil compulsorily. (Fig.8.4)

(5) Others

Jet lubrication, oil mist lubrication, air-operated oil lubrication, etc. are available as other lubrication methods.

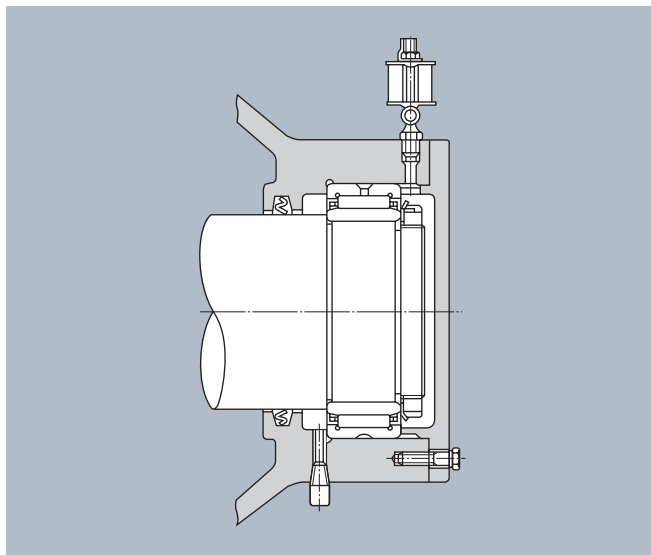

Fig. 8.3 Drip lubrication



Fig.8.4 Circulating lubrication

8.2.2 Lubrication oil

Mineral oils such as spindle oil, machine oil, turbine oil, etc. are mostly used as the lubrication oil for bearings. However, synthetic oils such as diester oil, silicone oil, fluorocarbon oil, etc. are used under the operating conditions wherein bearings are subjected to running at high temperature of 150°C and over or low temperature of -30°C and less.

For lubrication oil, its viscosity is one of the important characteristics that determine the lubrication performance. Too low viscosity of lubrication oil would cause imperfect forming of an oil film and finally cause damage of bearing surface, while too high viscosity of lubrication oil would cause great viscosity resistance, which would then lead to temperature rise and increase of friction loss.

Generally lubrication oil of lower viscosity is used for the faster rotational speed of bearing, while lubrication oil of higher viscosity is used for the heavier bearing load.

Lubrication of bearings needs the oil viscosity every each operating temperature which is specified in Table 8.4. Fig. 8.5 shows the lubrication oil viscosity - temperature characteristic chart, which is referred to in selecting a lubrication oil of optimal viscosity under actual operating temperature.

Furthermore, Table 8.5 shows the criterion for selection of the lubrication oil viscosity according to the actual bearing operating conditions.

Table 8.4 Oil viscosity required for each bearing type

Bearing type	Required viscosity mm ² /s
Radial needle roller bearing	13
Thrust needle roller bearing	20

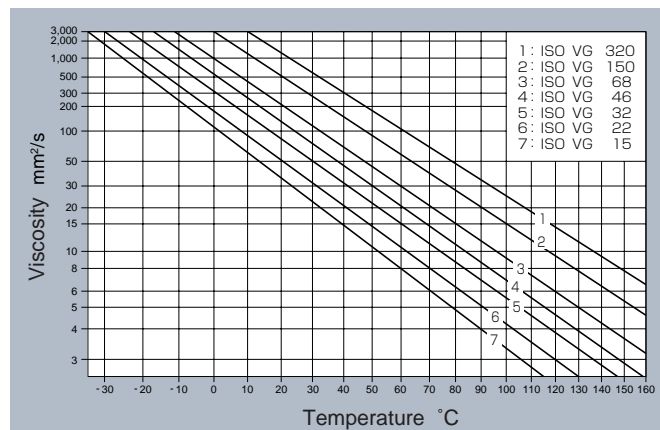

Fig. 8.5 Lubrication oil viscosity - temperature characteristic chart

Table 8.5 Criteria for selection of lubrication oil (Reference)

Bearing operating temperature °C	d_n value	ISO viscosity grades for lubrication oil (VG)	
		Ordinary load	Heavy load or shock load
-30~0	up to allowable rotational speed	22 32	46
0~60	up to 15000	46 68	100
	15 000~80 000	32 46	68
	80 000~150 000	22 32	32
60~100	up to 15000	150	220
	15 000~80 000	100	150
	80 000~150 000	68	100 150
100~150	up to allowable rotational speed	320	

Remarks:
 1. Subject to oil bath lubrication or circulating lubrication.
 2. Apply to NTN for other operating conditions other than those specified in this Table.

8.2.3 Oil quantity

Under an forced oil lubrication system, heat value generating from bearing, etc. is equal to the sum of heat value radiated from housing and heat value carried away by lubrication oil.

Where a standard housing is used, the oil lubrication quantity as a guideline can be determined by **formula (8.2)**. The radiated heat value differs depending on the shape /profile of a housing used. It is therefore desirable to determine the lubrication quantity best-suited to an actual equipment by adjusting it from a value approximately 1.5 to 2 times as much as the lubrication rate determined by formula (8.2). In addition, Where the lubrication quantity is calculated assuming that the generated heat value is all carried away by the oil, with no heat radiation from the housing, the oil quantity q can be determined, assuming that the shaft diameter on 2nd vertical line from the right side in (Fig. 8.6) Chart for Determination of Oil Quantity q is $d=0$.

$$Q = K \cdot q \dots\dots\dots(8.2)$$

Where,

Q : Oil quantity per bearing cm^3/min

K : Coefficient being determined by operating temperature rise of oil (**Table 8.6**)

q : Oil quantity that can be determined from the chart cm^3/min (**Fig.8.6**)

8.2.4 Fresh oil refilling interval

Although it depends on actual operating conditions, oil quantity and the kind of lubrication oil used, the fresh oil refilling interval as a guideline is around one year where bearings are lubricated with oil of 50°C and lower temperature by the oil bath method and is at least 3 months where bearings are lubricated with oil of 80 to 100°C.

For an important equipment it is desirable to monitor periodically the lubrication performance, cleanliness deterioration, etc. of the lubrication oil in use and to specify the fresh oil refilling interval under the monitor data.

Table 8.6 K-value

Discharged oil temperature - lubricating oil temperature °C	K
10	1.5
15	1
20	0.75
25	0.6

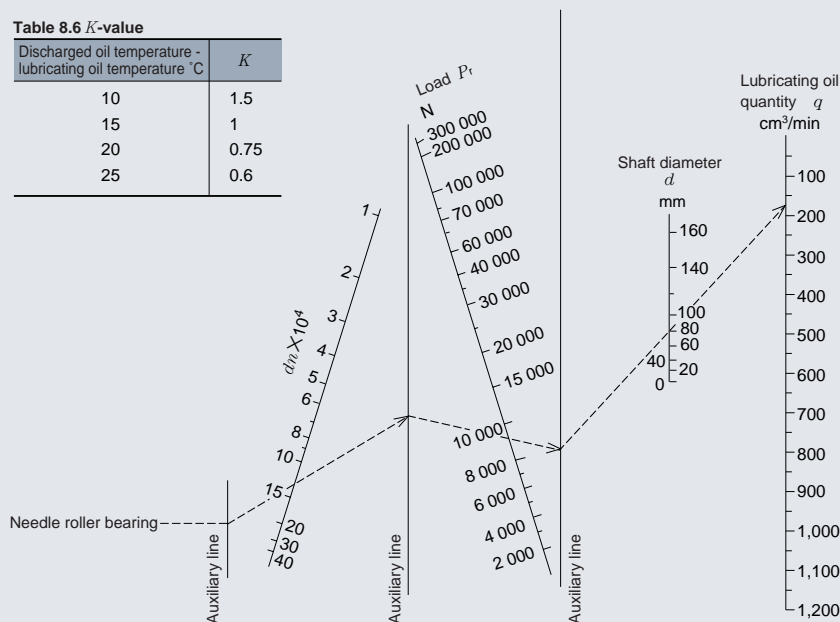

Fig. 8.6 Chart for determination of lubricating oil quantity

9. Sealing Devices

9.1 Non-contact seal and contact seal

The purpose of using a seal is to prevent a lubricant held in a bearing from leaking outside the bearing and to prevent powder, water content, etc. from invading into the bearing from outside.

It is very important to design a sealing device with good care, under full consideration of the operating conditions,

lubricating condition, environmental condition, economical merit, etc., so that bearing running is not inversely affected by the sealing device.

The bearing seals are mainly classified into non-contact seal, contact seal, etc. as shown in **Tables 9.1** and **9.2**, which must then be selected correctly according to each application, under full consideration of the characteristics of each sealing type.

Table 9.1 Seals (Non-contact seals)



Type	Non-contact seals		
	Seal type using a spacing	Seal type using a centrifuge	Seal type using air pressure
Seal name	Oil groove seal Labyrinth seal (axial, radial)	Slinger seal	Air seal
Features	<p><Oil groove seal> This seal is fitted at either one side of a housing or a shaft, or fitted at the both sides for sealing action. In this case, this seal has also an effect in preventing invasion of foreign matter from outside by holding grease in the oil groove.</p> <p>< Labyrinth seal > This seal having a high sealing effect due to its multi-stage labyrinths and long passage is mainly used for grease lubrication. Generally it is suited to high speed bearing running, but it has a dust-proofing effect even under low speed running if the seal grooves are filled up with grease. It is convenient if this seal is provided with a grease nipple.</p>	<p>In oil lubrication, this seal has an effect in slinging and returning the oil flown out along its sleeve by a centrifugal force if its sleeve is provided with projections.</p> <p>A seal example illustrated in Fig. 9.6 prevents invasion of foreign matter from outside.</p>	
Application examples	 <p>Fig. 9.1 Oil groove seal</p>	 <p>Fig. 9.4 Slinger with projections</p>	
	 <p>Fig. 9.2 Axial labyrinth seal</p>	 <p>Fig. 9.5 Slinger intended for back flow of flown-out oil by centrifuge</p>	
	 <p>Fig. 9.3 Radial labyrinth seal</p>	 <p>Fig. 9.6 Slinger provided at outer side</p>	

Table 9.2 Seals (Contact seals)

Seal type	Contact seals	
	Seal using mainly direct contact	Seal using mainly fluid lubrication and boundary lubrication
Seal name	Seal ring (felt seal, etc.) O-ring, piston ring	Oil seal, V-shaped ring seal, mechanical seal
Features	<p>This seal type seals a fluid perfectly by pressing its elastic body onto the sliding surface with a constant contact pressure. Generally the contact seals are more excellent in sealing performance than the non-contact seals, but the friction torque and temperature rise thereof are greater than those of the non-contact seals.</p> <p><Felt seal> This is the simplest of the contact seals, which is mainly used for grease lubrication and suited to prevention of fine dust, but oil penetration and outflow are occasionally unavoidable to some extent.</p>	<p>< Oil seal > This seal type intended to seal lubricant at the sliding portion between its lip and a shaft has good sealing effect and is an effective seal in the most frequent use. The lip must be oriented outward to prevent invasion of water content and foreign matter from outside and oriented inward to prevent lubricant from leaking out of the housing. Furthermore, another seal type with two or more lips is also available for preventing lubricant leak and dust-proofing individually.</p>
Application examples	 <p>Fig. 9.7 Felt seal</p>	 <p>Fig. 9.10 Oil seal</p>
	 <p>Fig. 9.8 Z type grease seal</p>	
	 <p>Fig. 9.9 GS type grease seal</p>	

9.2 Combined seals

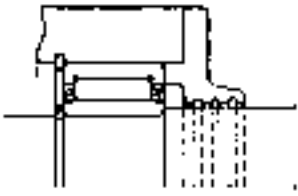
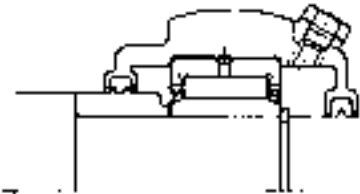
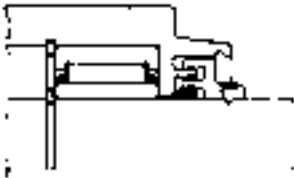
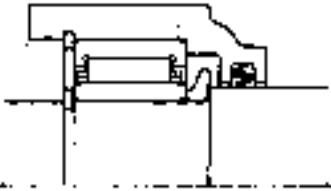
Several seal types are used in combination for a seal application under an environment where dust, water content, etc. exist so much or for mechanical portions which are not allowed to be contaminated by lubricant leak.

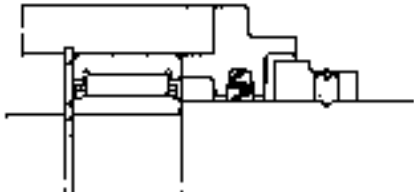
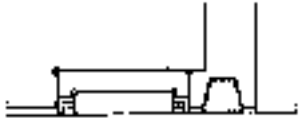
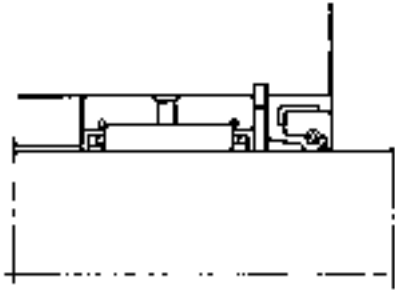
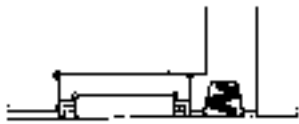
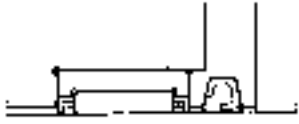
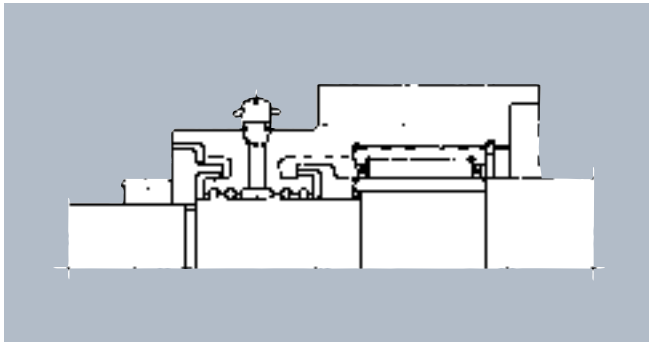

Fig. 9.11 Combined non-contact seal
Combination of labyrinth seal and oil groove seal

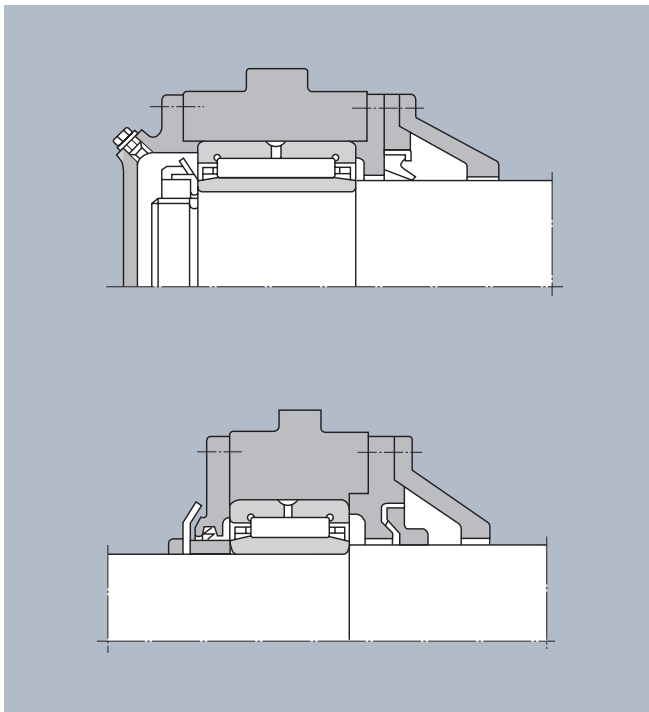

Fig. 9.12 Combined seal
Combination of contact seal and non-contact seal

9.3 Clearance setting

Oil groove seal and labyrinth seal have the better sealing effect as the shaft - housing clearance gets the smaller, but the actual clearance is generally selected from the following clearance values, under consideration of machining and assembling conditions, shaft deformation, etc.

Table 9.3 Clearances

Seal type	Shaft diameter	Radial clearance	Axial clearance
Oil groove seal	50 and less	0.2~0.4	—
	Over 50 to 200	0.5~1.0	
Labyrinth seal	50 and less	0.2~0.4	1.0~2.0
	Over 50 to 200	0.5~1.0	3.0~5.0

9.4 NTN seals

Special-purposed NTN seals are available for the needle roller bearings. (Refer to **Table 9.4** on page A-48.) For the more detailed information refer to "Dimensions Table" on page B-233.

9.5 Seal materials and corresponding operating temperature ranges

The oil seal lip is ordinarily made of nitril rubber, but acrylic rubber, silicone rubber and fluoro-rubber are used as the lip material according to atmosphere temperature, an objective to be sealed, etc. **Table 9.5** shows the operating temperature ranges available for the respective materials.

Table 9.5 Seal materials and corresponding operating temperature ranges (Reference)

Seal materials	Operating temperature ranges °C
Nitril rubber	-25~+100
Acrylic rubber	-15~+130
Silicone rubber	-70~+150
Fluoro-rubber	-30~+180
Felt	-40~+120

9.6 Seal types and allowable speed

The allowable speed for the contact seal type depends on the surface roughness, accuracy and lubrication property of sliding surface, operating temperature, etc. **Table 9.6** shows the allowable speed every each seal type, as a guideline.

Table 9.6 Seal types and corresponding allowable speed (Reference)

Seal types	Allowable peripheral speed m/s
Felt seal	4
Grease seal	6
Oil seal (Nitril rubber)	15
Oil seal (Fluoro-rubber)	32
V-ring seal	40

Table 9.4 Seals (NTN contact seals)

Seal type	Contact seals (G type, GD type)	
	Seal using mainly direct contact	
Features	<p>This seal type is a special-purposed seal for needle roller bearings which was designed for smaller section height so as to correspond flexibly to the said bearings.</p> <p>This is a synthetic rubber contact seal reinforced with steel plate, being then used in the operating temperature range of -25 to +120°C and, under continuous running condition, used at 100°C and less. For application under special operating conditions of over 120°C at operating temperature, etc., feel free to contact NTN for any inquiry.</p>	
Application examples		

Fig. 9.13 Bearing sealing by NTN seals (Example)

9.7 Shaft surface roughness

Sealing performance and seal life depend on the surface roughness, accuracy and hardness of shaft sliding surface with which the seal lip comes in contact.

Table 9.7 shows the surface roughness as a guideline. For improving better the wear resistance of shaft surface it is desirable to secure the shaft surface hardness at least at HRC40 and over (at HRC55 and over if possible) by heat treatment and hard chrome plating.

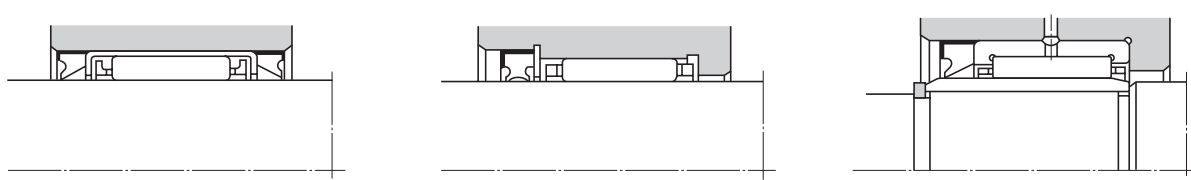
Table 9.7 Shaft surface hardness (Reference)

Peripheral speed m/s		Surface roughness
over	incl.	Ra
	5	0.8a
5	10	0.4a
10		0.2a

10. Bearing Handling

A rolling bearing is a precision part. It must be handled very carefully to keep its preciseness unchanged. Particularly the handling instructions given hereunder must be observed in handling.

[1] Keeping bearing and other related parts clean

Foreign matters such as mist, dust, etc. would cause harmful affect on bearing running and life. To avoid such harmful effect, bearing and other parts mounted adjacent to the bearing must be kept clean and, in addition, handling tools, lubricant, washing oil, work environment, etc. must always be maintained in clean condition respectively.

[2] Careful handling

Any shock to a bearing in handling would result in surface flaw and indent of its raceway surface and rolling elements and, in the worst case, result in cracking and chipping. To avoid such defects and trouble, bearings must be handled with good care.

[3] Use of proper handling tools

It should be avoided to use another inappropriate tool as an alternative of the specific tool in installing and removing.

Specific tools suited to the individual bearing types must be used. The special-purposed handling tools must be used particularly when installing a drawn cup needle roller bearing.

[4] Protection of bearing from rusting

A rust preventive oil is coated on all of bearings, as a rule. However, direct handling of bearings by the bare hands would cause rusting of the bearings from adhesion of hand sweat thereto. To protect bearings from rusting, a pair of gloves must be put on or otherwise mineral oil be coated on the hands in the case of direct handling by the bare hands.

10.1 Bearing storage

Bearings are all shipped after coated with rust inhibitor and packaged. It is desirable to store bearings at room temperature and relative humidity of 60% and less. The storage period of a grease-filled and sealed bearing is limited to the specific lifetime of non-greased bearing.

10.2 Installation

Although depending on bearing type and fitting conditions, the bearing installing methods described hereunder are selectively available as the general method. However, refer to Commentary given in the Dimensions Table for installation of the drawn cup needle roller bearings.

(1) Preparations prior to installing

For installation of bearings it is desirable to prepare a cleaned and dried work place.

Contaminant, burr, chips, etc. must be removed completely from all the parts related to a shaft and a housing before installing.

Furthermore, the bearing mount must be inspected to verify whether its dimensional accuracy, profile accuracy and surface roughness are within the respective specified tolerance ranges.

Bearings are all unpacked before installing. In the case of using bearings with grease lubrication, generally they may be installed as are without washing off the rust inhibitor coated thereon.

Where a bearing is used with oil lubrication or the lubricating function of a grease-lubricated bearing is impaired by a mixture of grease and rust inhibitor, however, the bearing must be installed after complete removal of the rust inhibitor by clean washing oil.

It is not allowed to wash shield type and seal type bearings and one-way clutch.

(2) Press-fit by a press machine

In general, the press-fit method using a press machine is widely used for installation of bearings. In detail, the bearing ring (inner ring or outer ring) is press-fitted slowly via a backing strip as illustrated in Fig. 10.1. **It is not allowed to apply the press force to a bearing via its rolling elements like a bad example illustrated in Fig. 10.2 (page A-50).**

Further, a small size bearing with small interference may be installed by hammering the bearing ring with a plastic hammer or the like. **In that case, however, the uniform hammering force must be applied to the bearing side face via the backing strip as illustrated in Fig. 10.1, because direct hammering to the bearing end face or partial hammering by use of a punch could impair the specific bearing performance.**

Fitting the inner ring on a shaft by hammering the outer ring or fitting the inner ring by hammering itself would result in surface flaw and indent of the raceway surface and the rolling elements. Therefore, doing so must be avoided absolutely.

Also, friction of the fitting surface can be reduced by coating high viscosity oil on the surface.

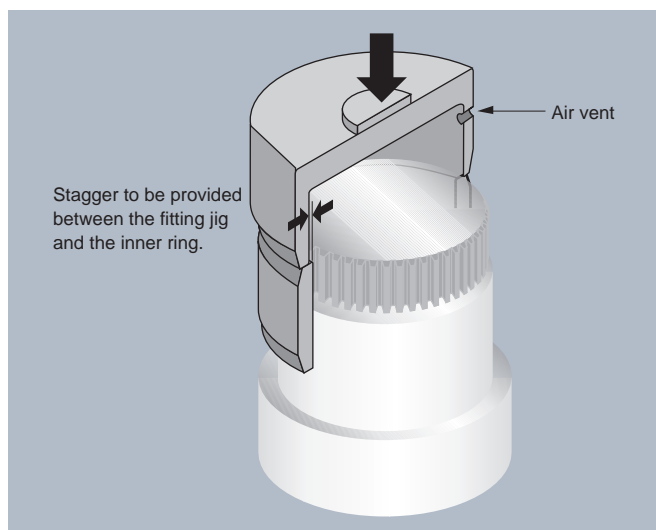

Fig. 10.1 Press-fitting of inner ring

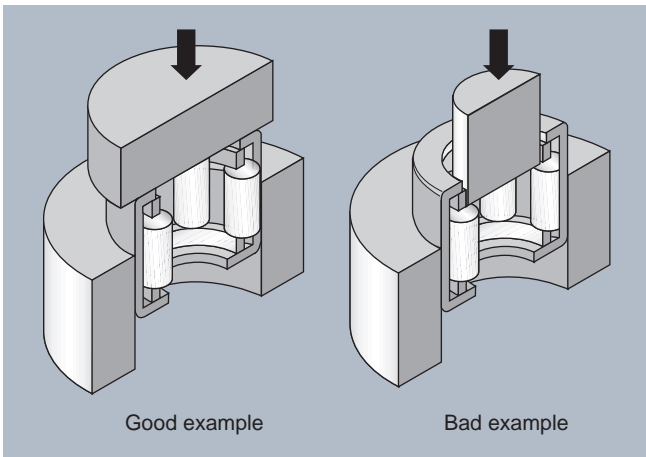

Fig.10.2 Press-fit

(3) Shrinkage fit

This shrinkage fit method is to fit the inner ring on a shaft after dipping it in hot oil for thermal expansion of its bore. This method is also widely used for installation of bearings. In heating the inner ring, low-corrosive mineral oil or the like is used. In this case, the heated inner ring is natural-cooled down after shrinkage-fit, but simultaneously it shrinks in axial direction, too. Therefore, the inner ring must be pressed to the shaft shoulder until adequate cool-down, so as not to allow a clearance between the inner ring and the shoulder.

In any case, however, it is not allowed to heat the inner ring up to over 120°C.

Fig. 10.3 shows the relationship of inner ring bore thermal expansion to heating temperature.

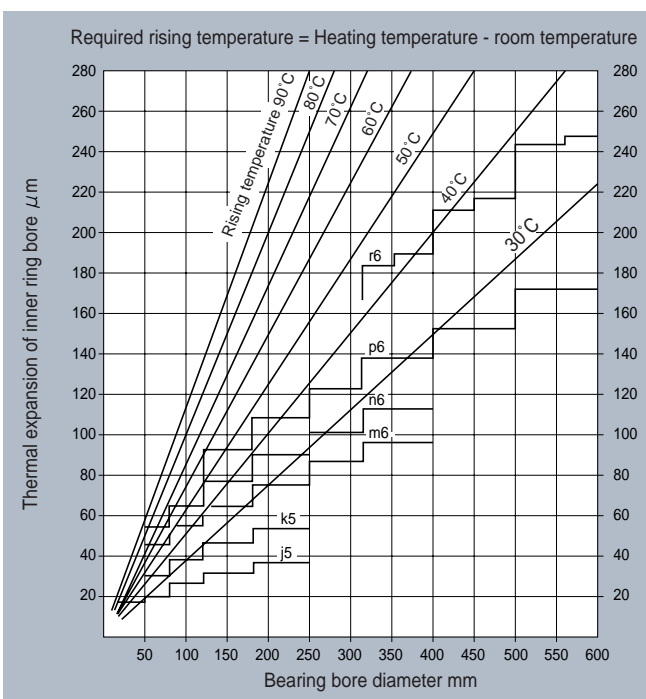

Fig. 10.3 Rising temperature required for shrinkage fit of inner ring

10.3 Post-installation running test

Bearing running test must be conducted on an installed bearing to check whether it was installed correctly. In this case, accelerating immediately the running speed up to the rated speed must be avoided absolutely. Doing so could result in damage of the bearing in the case of imperfect installation and seizure of the bearing in the case of inadequate lubrication. In testing, therefore, the shaft or the housing must first be rotated by hand and thereafter the shaft be rotated at low speed under no-load condition by the driving power, unless any failure is detected upon checking. After that, the running speed and load on the bearing must be accelerated and increased gradually while checking the running condition.

Running sound level and tone of a bearing can be checked by a sound scope held in contact with the bearing housing. The sound is normal if it is a pure sound upon checking. In this case, high metallic sound or irregular sound from the bearing, if any, reveals occurrence of somewhat failure. In such a case, possible cause of the failure can be presumed by measuring quantitatively vibration amplitude and frequency using a vibrometer.

Generally bearing temperature is presumed from the circumferential temperature of a housing. However, it can be judged more exactly if possible to measure directly the outer ring temperature by utilizing the oil hole thereof, etc.

Needless to say, bearing temperature rises with elapse of the running time and reaches a constant level after a certain time. Rapid bearing temperature rise or continued temperature rise in excess to the constant level or abnormally high bearing temperature would reveals occurrence of somewhat failure. In such a case, careful check is required.

Table 10.1 shows the required check items.

Table 10.1

Hand operation	Variation in torque Over-torque Chattering Abnormal sound	Imperfect installation Under-clearance, great seal friction, etc. Indent and flaw on raceway surface Inclusion of dust and other foreign matter
Power operation	Abnormal noise and vibration Abnormal temperature	Inclusion of dust and other foreign matter, indent on raceway surface, over-clearance, inadequate lubrication Use of improper lubricant, imperfect installation, under-clearance

10.4 Bearing removal (dismounting)

Some related bearings are removed from each shaft, incurred by periodic disassembly or incidental trouble of a machine. In this case, these bearings must be handled with good care similarly to the case of installation, when they are reused or the condition thereof is examined after removed (dismounted). Too tight fit of a bearing would incur difficulty in dismounting and, therefore, the bearing-related construction must be fully considered in design of

the bearing fixing method.

Regarding the dismounting method, generally the press method (Fig. 10.4) and the puller method (Fig.10.5) are available for dismounting inner ring though depending on bearing type and fitting conditions.

When inner ring is dismounted from a shaft by heating, good care must be exercised not to over-heat the inner ring.

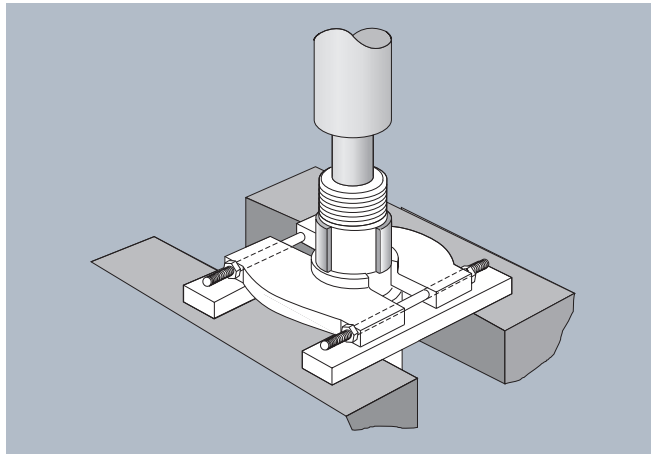

Fig. 10.4 Bearing removal by a press machine

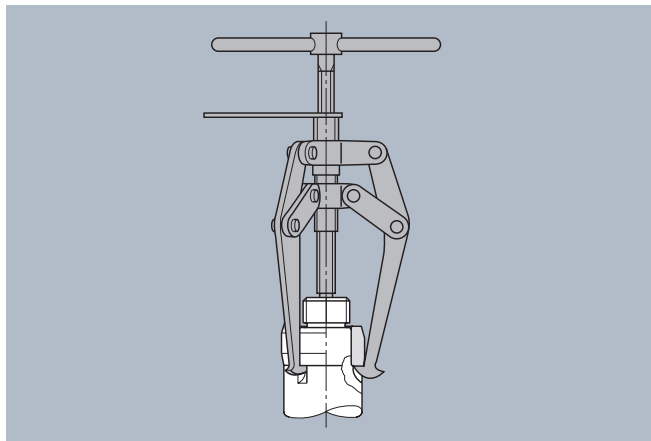

Fig. 10.5 Bearing removal by a puller

10.5 Force required for press-fit and pull-out

The force required for press-fitting or pulling out inner ring on / from a shaft can be determined by formula (10.1).

$$K_a = f_k f_E \frac{d}{d+3} \Delta d_F \dots \dots \dots (10.1)$$

Where,

- K_a : Force required for press-fitting or pulling-out N (kgf)
- f_k : Resistance factor being determined by shaft to inner ring friction factor
 - For press-fitting..... 40 (4)
 - For pulling-out.....60 (6)
- f_E : Coefficient depending on inner ring dimension

$$f_E = B \left[1 - \left(\frac{d}{F_1} \right)^2 \right]$$

- B : Inner ring width mm
- d : Inner ring bore diameter mm
- F_1 : Mean outer diameter of inner ring mm
- Δd_F : Apparent interference μm

Actual press-fit force and pull-out force could eventually exceed the respective calculate value due to installing error. Hence, it is recommended to design the dismounting tools so as to have the strength (rigidity) resistible to a load 5 times as much as the calculated press-fit force and pull-out force.

10.6 Washing

Rotating a bearing with foreign matter adhered thereto could result in damage of the raceway surface, etc. Therefore, any dismounted bearing is usually washed by light oil or kerosene or the like for complete removal of foreign matter. In this case, two washing vessels must be used as follows; one for rough washing and another for finish washing. Rough washing is done for removal of oil and foreign matter from bearing, while finish washing is done for fine washing of the roughly-washed bearing. Further, any vessels used for washing must be provided with a steel net as the middle bottom above the vessel bottom, as illustrated in Fig. 10.6, to prevent the bearing from coming in direct contact with the vessel bottom.

Furthermore, rust preventive treatment must be applied to the washed bearing immediately after washing, to thereby protect it from a risk of corrosion.

In addition, the legal requirements as applicable (environmental preservation, industrial labor safety and health, etc.) and the washing specification submitted from a detergent manufacturer must be taken in consideration in washing.

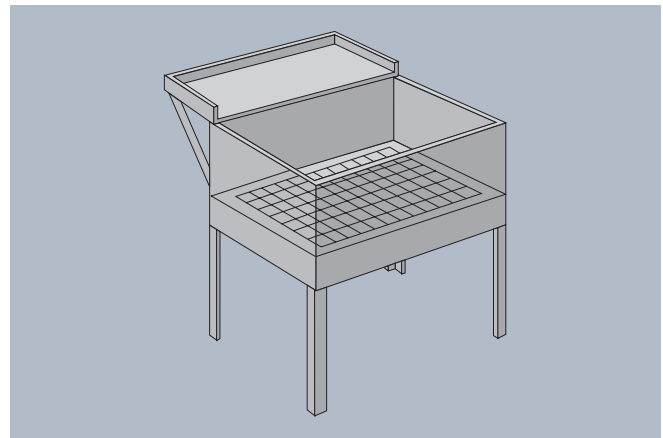

Fig. 10.6 Washing tank

11. Technical Data

11.1 HL Bearing

The form of bearing separation life can be mainly classified into the internal origin type and the surface origin type. Bearing separation of the surface origin type is said to occur in an inadequately lubricated area and it is widely recognized that the bearing separation life correlates to the oil film parameter that can be determined by "Elastic Fluid Lubrication Theory (EHL Theory)".

This oil film parameter must be increased for controlling the surface origin type separation and, for that, the bearing manufacturers have made possible effort for better improvement of lubricant and for upgrading of the bearing rolling raceway surface roughness.

In recent years it has been proposed by the relative field that the capability of forming an oil film on contact surfaces could be improved better by changing the form and directivity of surface roughness of machined parts.

On the other hand, NTN developed successfully long life HL (High Lubrication) bearings under "Micro EHL Theory" as one of the countermeasures against surface origin type separation. And these HL bearings have been widely used in each field since developed.

11.1.1 Basic concept of HL bearing

Fig. 11.1 illustrates the basic concept of the HL bearing.

In this Figure, the hatched area shows a contact portion deformed elastically and the dotted line shows the lubrication flow, based on "Internal lubrication fluid flow model in contact portion" disclosed by H.S. Cheng and others.

Lubricant flow in (B) has a resistance greater than that in (A). This means that the quantity of a fluid existing internally in the contact portion increases. In other words, the thickness of an oil film formed on the rolling contact surface increases with increase of the fluid quantity.

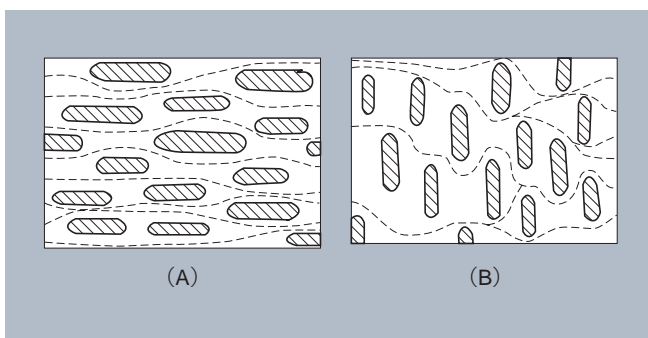

Fig. 11.1 Directivity of finished surface and lubrication fluid flow model

11.1.2 HL surface

Fig. 11.2 is a magnified photo showing roller surface. In this Figure the blackened spots are micro recessed spots and, as seen from this Figure, a number of micro oil pots of around several tens μm exist at random. The recessed spots on this surface can be modified into any optional size and the number of spots by changing the machining conditions. Fig. 11.3 shows the bus line form of the HL surface, from which the depth of the micro recessed spots is nearly 1 μm.

11.1.3 HL bearing application examples

The HL surface-treated bearings are widely used in various fields. For example, they are used for car transmission, hydraulic devices, various reduction gears, etc.

As an example of special application, HL surface treatment is applied to the special-purposed bearing for the rocker arm of car engine. This is highly appreciated as an effective seizure preventive measure.

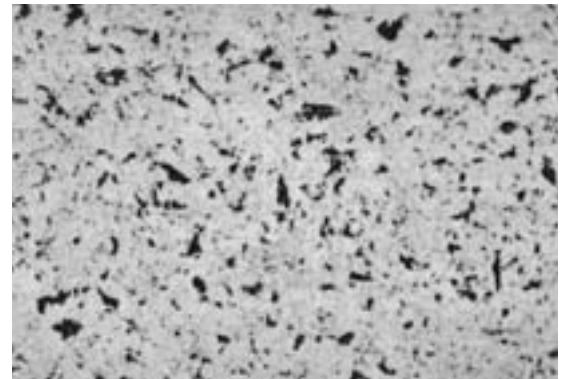

Fig. 11.2 Magnified photo showing roller surface

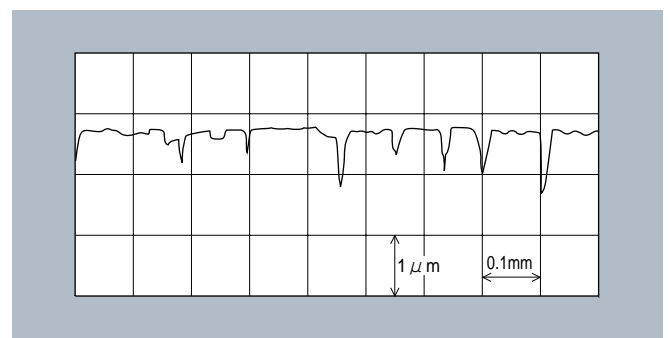

Fig. 11.3 Bus line form of HL surface

11.2 Bearings with Solid Grease

Bearings with Solid Grease means a bearing in which thermal solidification type grease (mainly composed of lubrication grease and resin) is filled as a lubricant material.

Once this thermal solidification type grease (referred to as Bearings with Solid Grease) was heated and cooled down (hereinafter referred to "heat treatment"), the paste-like grease hardens as much lubricant held unchanged.

The Bearings with Solid Grease is solidified after heat treatment so that the lubricant does not leak easily even in the case wide amplitude vibration and strong centrifuge act on the bearing, thus contributing to prevention of lubricant leak and longer bearing life.

The spot pack specification in which Bearings with Solid Grease was packed at multiple points on the cage and the full pack specification in which Bearings with Solid Grease was nearly full-packed in the spacing volume of bearing are both available for the Bearings with Solid Grease. Further, the needle roller bearings are all based on the full pack specification.

11.2.1 Characteristics of Bearings with Solid Grease

(1) Less lubricant leak

Bearings with Solid Grease holds much lubricant internally in bearing because it is solidified after heat treatment. This lubricant is gradually fed onto the rolling surface by heat generating from the bearing and centrifuge, whereby lubricant leak is minimized. This serves to prevent the peripheral environment from being contaminated, comparing with general lubrication greases.

(2) Good lubricating characteristic

Even when wide amplitude vibration and strong centrifuge act on a bearing, lubricant does not leak easily and, in addition, Bearings with Solid Grease does not emulsify and flow out easily, because of its solid type, even in the case of water content inflow to bearing.

Thus, the lubricating characteristic is more excellent than general lubrication greases.

(3) Sealing effect

Bearings with Solid Grease acts as a preventive barrier against foreign matters (water content, dust, etc.) invading from outside, but does not function perfectly as a seal. Therefore, use of the contact type rubber seal (for deep groove ball bearing, bearing unit) or another seal (for other bearings) is recommended particularly when high sealing performance is required.

11.2.2 Attentive points in using Bearings with Solid Grease

- (1) The needle roller bearing dimension to accept Bearings with Solid Grease differs every each bearing type. Feel free to contact NTN for the detail.
- (2) The allowable temperature range is -20°C to 80°C, but 60°C and less for continuous long term running. Fully note the operating temperature.
- (3) Allowable rotational speed $F_w \cdot n$ value (F_w = inscribed circle diameter [mm]) \times (n = operating rotational speed [r/min]) is differs from that in use of general grease and lubrication oil. Fully note this matter.
Use any needle roller bearings on $F_w \cdot n$ value = 30,000 and less.
- (4) For the bearings of the full pack specification, minimum load equivalent to at least around 1% of the basic dynamic load rating is needed for enabling the rolling elements to run without slipping.
- (5) Bearings with Solid Grease acts as a preventive barrier against foreign matter invading from outside, but does not function perfectly as a seal. Therefore, combined use of Bearings with Solid Grease and rubber seal is recommended particularly when high sealing performance is required.

11.2.3 Application examples of Bearings with Solid Grease bearings

- Bearing for the paper feeder of a printing machine
- Bearing for the mast roller guide of a forklift
- Support bearing for the swing arm of a two-wheeled car
- Bearing for a machine tool
- Guide bearing for the guide unit of a press machine
- Bearing for the link mechanism of an automatic loom
- Bearing for the conveyor guide of a food packaging machine



11.3 Calculation Examples

11.3.1 Shrinkage factor and post-installation clearance of drawn cup needle roller bearing

The recommended fit data for the standard bearings is as described in **Table 1** on page B-33. This paragraph describes hereunder the calculation methods to be used when the bearing fit conditions are reviewed in detail.

1) Calculation of bearing shrinkage factor

For the drawn cup bearings, the shrinkage factor is calculated using the following method.

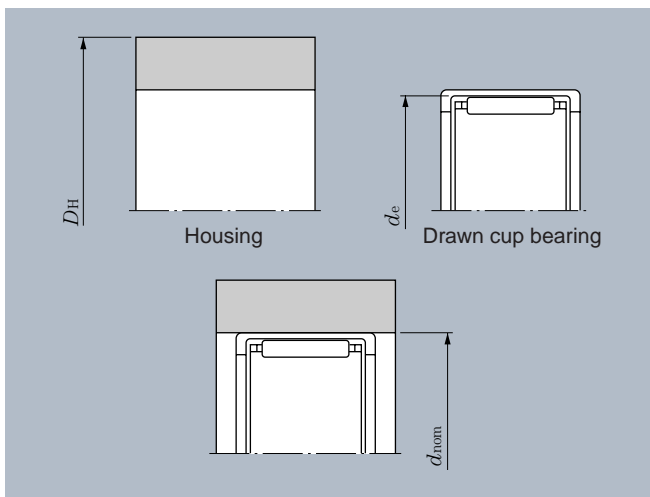

Fig. 11.4

$$\lambda = \frac{2t}{E_2} \cdot \frac{1-S^2}{\frac{(0.7S^2+1.3)(1-t^2)}{E_1} + \frac{(0.7+1.3t^2)(1-S^2)}{E_2}} \dots (11.1)$$

Where,

- λ : Outer ring shrinkage factor
- D_H : Housing outer diameter mm
- d_{nom} : Nominal diameter of fitting portion mm
- d_e : Rolling surface diameter of outer ring mm
- E_1 : Modulus of housing vertical elasticity (Young's modulus) MPa (kgf/mm²)
- E_2 : Modulus of outer ring vertical elasticity (Young's modulus) 2.07 × 10⁸MPa (21 200kgf/mm²)

$$S = \frac{d_{nom}}{D_H}$$

$$t = \frac{d_e}{d_{nom}}$$

2) Inscribed circle diameter after complete bearing fit in the housing on actual machine

[1] Inscribed circle diameter in press-fitting of master ring

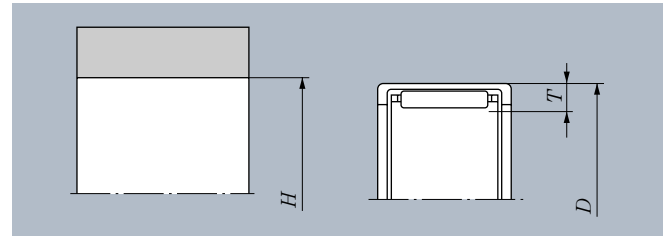

Fig. 11.5

- H : Housing inner diameter mm
- T : Roller diameter + plate thickness mm
- D : Outer diameter of drawn cup needle roller bearing mm
- L_i : Post press-fit inscribed circle diameter mm

When the master ring is press-fitted, the dimension of "roller diameter + plate thickness" remains unchanged. Hence, the inscribed circle diameter L_i is determined by the following formula.

$$L_i = D - 2T - \lambda(D - H) = (1 - \lambda)D - 2T + \lambda H \dots (11.2)$$

Determine the mean value of "roller diameter + plate thickness" (=T) and standard deviation from formula (11.2). The mean value of formula (11.2) is determined as follows.

$$m_{L_i} = (1 - \lambda) m_D - m_{2T} + \lambda m_H \dots (11.3)$$

Standard deviation of formula (11.2)

$$\sigma_{L_i2} = (1 - \lambda)_2 \cdot \sigma_{D2} + \sigma_{2T2} + \lambda_2 \sigma_{H2} \dots (11.4)$$

In the case of master ring, due to $\sigma_{H2} = 0$ the formula (11.4) is expressed as follows.

$$\sigma_{L_i2} = (1 - \lambda)_2 \cdot \sigma_{D2} + \sigma_{2T2} \dots (11.5)$$

The unknown values in formulas (11.3), (11.5) are only m_{2T} and σ_{2T^2} . Hence, substitute the known numerical values for formulas (11.3), (11.5) to determine m_{2T} and σ_{2T^2} .

[2] Even when bearing ring is press-fitted in the housing on actual machine, consider the inscribed circle diameter similarly to the master ring press-fit. Herein, the calculation formulas for press-fit in the housing on actual machine can be discriminated as follows from formula (11.3), (11.4) by adding " ' " to each formula.

$$m_{L_i'} = (1 - \lambda') m_D - m_{2T'} + \lambda' m_H \dots (11.6)$$

$$\sigma_{L_i'2} = (1 - \lambda')_2 \cdot \sigma_{D2} + \sigma_{2T'2} + \lambda'_2 \sigma_{H'2} \dots (11.7)$$

[3] For m_{2T} and σ_{2T^2} in formula (11.6), (11.7), substitute the values determined previously for the respective formula.

[4] From the calculations, the inscribed circle diameter in press-fitting in the housing on actual machine can be

expressed in the following formula

$$L_i' = m L_i \pm 3 \sigma L_i' \dots\dots\dots(11.8)$$

[5] Radial internal clearance can be determined considering the mean value and standard deviation of shaft in formulas (11.6), (11.7).

[6] The aiming radial internal clearance value is generally set up so an ordinary clearance can be got. However, the recommended clearance values are available every the individual portions in the case of bearing application to automobile. Feel free to contact NTN for the detail.

11.3.2 Track load capacity of cam follower and roller follower

The reference hardness (reference tensile stress) was set up from the relationship between the follower hardness and net tensile stress of the material and the track load capacity was determined

from the relationship of the setup reference stress to hertz stress.

How to set up the reference hardness (tensile stress) differs a little bit depending on each bearing manufacturer. Herein, the relevant Table appended to "JIS Handbook for Irons and Steels" was used as the hardness - tensile stress relationship.

(Approximate numerical value under JIS Z8413 Revised Conversion Table)
For HRC40, $\sigma = 1.245\text{MPa}$ (127kgf/mm²) was adopted as the reference hardness (tensile stress).

<Track load capacity adjustment factor>

The tensile stress strength of the follower material increases with increase of its hardness, and the track load capacity of the follower increases incurred by increase of the tensile strength strength. In this case, the load capacity increase rate can be determined by multiplying the track load capacity by applicable track load capacity adjustment factor shown in **Table 11.1**.

Note) The track load capacity determined herein is based on net tensile stress as the reference, not allowable hertz stress. Generally stress (specific stress) resulting in creep of follower material is greater than the tensile stress. Particularly in the case of static load, this track load capacity comes to a safety side value.

[Ex.] Determination of load capacity T_c' of track with certain hardness by use of track load capacity adjustment factor.

Assuming track load capacity described in Dimensions Table as T_c and track load capacity adjustment factor at applicable hardness as G respectively, the track load capacity T_c' can be determined as follows.

$$T_c' = G \cdot T_c$$

For hardness HRC50 at NATR15X,
 $T_c = 11\,900\text{N}$ (1 220kgf), $G = 1.987$
 $\therefore T_c' = 1.987 \times 11\,900\text{N}$ (1 220kgf)
 $= 23\,645\text{N}$ (2 424kgf)

Reference (Track load capacity calculation process)

• For a cylindrical outer ring

$$\sigma_{\max} = \frac{1}{60.9} \sqrt{\frac{T_c \sum \rho}{B_{\text{eff}}}}$$

• For spherical R outer

$$\sigma_{\max} = \frac{187}{\mu \nu} \sqrt[3]{(\sum \rho)^2 T_c}$$

$\sigma_{\max} = 1\,245\text{MPa}$ (127kgf/mm²)
 T_c : Track load capacity N (kgf)
 $\sum \rho$: Sum of curvature
 B_{eff} : Effective contact length mm
Herein (Outer ring width - chamfer)
 $\mu \nu$: Factor being determined by curvature

Table 11.1 Track load capacity adjustment factor

Hardness HRC	Tensile strength MPa {kgf/mm ² }	Adjustment factor G	
		for cylindrical outer ring	for spherical R outer ring
20	755 {77}	0.368	0.223
21	774 {79}	0.387	0.241
22	784 {80}	0.397	0.250
23	804 {82}	0.417	0.269
24	823 {84}	0.437	0.289
25	843 {86}	0.459	0.311
26	862 {88}	0.480	0.333
27	882 {90}	0.502	0.356
28	911 {93}	0.536	0.393
29	931 {95}	0.560	0.419
30	951 {97}	0.583	0.446
31	980 {100}	0.620	0.488
32	1 000 {102}	0.645	0.518
33	1 029 {105}	0.684	0.565
34	1 058 {108}	0.723	0.615
35	1 078 {110}	0.750	0.650
36	1 117 {114}	0.806	0.723
37	1 156 {118}	0.863	0.802
38	1 176 {120}	0.893	0.844
39	1 215 {124}	0.953	0.931
40	1 245 {127}	1.0	1.0
41	1 294 {132}	1.080	1.123
42	1 333 {136}	1.147	1.228
43	1 382 {141}	1.233	1.369
44	1 431 {146}	1.322	1.519
45	1 480 {151}	1.414	1.681
46	1 529 {156}	1.509	1.853
47	1 578 {161}	1.607	2.037
48	1 637 {167}	1.729	2.274
49	1 686 {172}	1.834	2.484
50	1 754 {179}	1.987	2.800
51	1 823 {186}	2.145	3.141
52	1 882 {192}	2.286	3.455
53	1 950 {199}	2.455	3.847
54	2 009 {205}	2.606	4.206
55	2 078 {212}	2.787	4.652

11.3.3 Outer ring strength

Generally any outer ring never breaks down as long as the load acting it is a usual operating load. This paragraph describes hereunder the strength calculation method to be used when the outer ring strength under shock load and heavy load is reviewed.

The outer ring strength can be determined using the formula given hereunder, assuming the respective outer ring profiles as illustrated in **Fig. 11.6**. In this case, the outer ring rupture strength means the bridged rupture strength of roller.

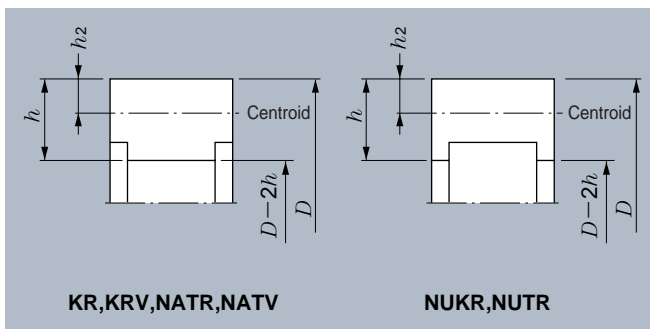

Fig. 11.6

Regarding how to set up breaking stress, in general 1760MPa (180kg/mm²) can be set up as the breaking stress for bearing steel, but it is desirable to set up the breaking strength with safety-side value (1170MPa [120kgf/mm²]), where stress concentration is taken into account. Generally any outer ring never break down as long as the load acting on it is usual operating load, but it necessary to check the rupture structure of outer ring, where shock load and heavy load act on it.

$$P = \frac{4\pi}{1+f(\alpha)} \times \frac{D-2h}{h(D-2h)^2} \times I \times \sigma$$

Where,

$$f(\alpha) = \frac{(\pi - \alpha) \sin \alpha - (1 + \cos \alpha)}{2 \cos \alpha}$$

$$\alpha = \frac{\pi}{Z} \text{ (rad.)}$$

- P : Breaking load (N)
- I : Secondary moment of outer ring section (mm⁴)
- Z : Number of rollers
- σ = Breaking stress (MPa)
- D, h, h₂ : per **Fig. 11.6** (mm)

11.3.4 Stud strength of cam follower

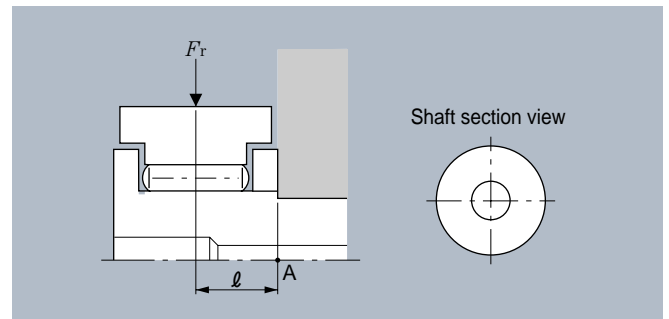

Fig. 11.7

When load Fr acts on the center point of outer ring as illustrated in **Fig.11.7**, bending moment Fr · l generates and consequently bending stress σ₁ (deemed as tensile stress) acts on the stud surface. In addition to this bending stress, tensile stress σ₂ generates from screw tightening because the stud itself is clamped to machine body with nuts. The stud strength can be reviewed from comparison of the sum (σ₁ + σ₂) of these two tensile stresses with allowable stress σ for the stud material.

$$\sigma_1 + \sigma_2 < \sigma$$

$$\sigma_1 = \frac{F_r \cdot l}{Z} \quad \begin{matrix} F_r : \text{Maximum radial load} \\ Z : \text{Coefficient of shaft section through Point-A} \end{matrix}$$

$$\sigma_2 \doteq 98\text{MPa (10kgf/mm}^2\text{)}$$

Tensile stress generating from maximum tightening torque described in "Dimensions Table"

σ : Allowable stress for material

The following values are adopted from the repeated bending test result of the stud material.

Where the stud material is subjected to static bending stress;

$$\sigma = 1372\text{MPa (140kgf/mm}^2\text{)}$$

Where the stud material is subjected to repeated bending stress (single direction)

$$\sigma = 784\text{MPa (80kgf/mm}^2\text{)}$$

Where the stud material is subjected to repeated bending stress (double directions)

$$\sigma = 392\text{MPa (40kgf/mm}^2\text{)}$$

Accordingly,

$$F_r < \frac{Z}{l} (\sigma - \sigma_2)$$

12. Bearing Type Symbols and Auxiliary Symbols

Table 12.1 Bearing Type Symbols

Type code	Bearing type
811	Single-direction thrust cylindrical roller bearing, dimension series 11
812	Single-direction thrust cylindrical roller bearing, dimension series 12
893	Single-direction thrust cylindrical roller bearing, dimension series 93
A	Needle roller, spherical type
AS11	Steel plate thrust washer, dimension series 11
ARN	Needle roller bearing with double-direction thrust cylindrical roller bearing
AXK11	Thrust needle roller bearing, dimension series 11
AXN	Needle roller bearing with double-direction thrust needle roller bearing
BF	Metallic flat cage for linear flat rollers
BK	Drawn cup needle roller bearing with close end
BR	Snap ring for bearing housing
CRV	Full complement roller for cam follower,
DCL	inch series Drawn cup needle roller bearing with open end, inch series
F	Needle roller, plane type
FF	Linear flat roller
FR	Bottom roller, for drawing frame (textile machine)
FRIS	Bottom roller
G	Synthetic rubber seal, one-lip type
GD	Synthetic rubber seal, double-lip type
GK	Needle rollers with split type cage
GS811	Outer ring for thrust bearing, dimension series 11
GS812	Outer ring for thrust bearing, dimension series 12
GS893	Outer ring for thrust bearing, dimension series 93
HCK	Drawn cup needle roller bearing for cross joint
HF	One-way clutch
HFL	One-way clutch integral with bearing
HK	Drawn cup needle roller bearing with open end
HMK	Drawn cup needle roller bearing with open end, for heavy load application
IR	Inner ring
JF · S	Arms for tension pulley and jockey pulley
JPU · S	Tension pulley and jockey pulley
K	Needle rollers with cage
K811	Thrust cylindrical roller, dimension series 11
K812	Thrust cylindrical roller, dimension series 12
K893	Thrust cylindrical roller, dimension series 93
KBK	Needle roller and cage assembly for small ends
KD	Linear ball bearing, stroking type
KH	Linear ball bearing, drawn cup type
KLM	Linear ball bearing, machined ring type
KLM · S	Linear ball bearing, clearance-adjustable type
KLM · P	Linear ball bearing, open type
KR	Cam follower
KRU	Cam follower, shaft eccentric type
KRV	Cam follower, full complement roller type
KRVU	Cam follower, full complement roller and shaft eccentric type

Type code	Bearing type
MI	Inner ring, inch series
MR	Machined ring needle roller bearing without inner ring, inch series
NA22	Roller follower with inner ring, dimension series 22
NA48	Machined ring needle roller bearing with inner ring, dimension series 48
NA49	Machined ring needle roller bearing with inner ring, dimension series 49
NA59	Machined ring needle roller bearing with inner ring, dimension series 59
NA69	Machined ring needle roller bearing with inner ring, dimension series 69
NA49 · S	Clearance-adjustable needle roller bearing with inner ring
NAO	Machined ring needle roller bearing, separable type, with inner ring
NATR	Roller follower
NATV	Roller follower, full complement roller type
NIP	Grease nipple
NK	Machined ring needle roller bearing without inner ring
NKIA59	Complex bearing : Needle roller bearing with angular ball bearing dimension series 59 Complex bearing
NKIB59	Needle roller bearing with three-point contact type ball bearing dimension series 59
NKX	Complex bearing : needle roller bearing with thrust ball bearing without dust-proof cover
NKX · Z	Complex bearing: Needle roller bearing with thrust ball bearing with dust-proof cover
NKXR	Complex bearing: Needle roller bearing with thrust cylindrical roller bearing without dust-proof cover
NKXR · Z	Complex bearing: Needle roller bearing with thrust cylindrical roller bearing with dust-proof cover
NUKR	Cam follower, full complement roller type
NUTR2	Roller follower, diameter series 2
NUTR33	Roller follower, diameter series 3
NUTW	Roller follower outer ring, middle rib type
PK	Needle roller and cage assembly
RF	Polyamide resin cage for linear flat rollers
RLM	Linear roller bearing
RNA22	Roller follower without inner ring, dimension series 22
RNA48	Machined ring needle roller bearing without inner ring, dimension series 48
RNA49	Machined ring needle roller bearing without inner ring, dimension series 49
RNA59	Machined ring needle roller bearing without inner ring, dimension series 59
RNA69	Machined ring needle roller bearing without inner ring, dimension series 69
RNA49 · S	Clearance-adjustable needle roller bearing, without inner ring
RNAB2	Open type roller follower without inner ring, diameter series 2
RNAO	Machined ring needle roller bearing, separable type, without inner ring
WR	Snap ring for shaft
WS811	Thrust inner ring, dimension series 11
WS812	Thrust inner ring, dimension series 12
WS893	Thrust inner ring, dimension series 93

Table 1.2.2 Auxiliary symbols

Symbol		Symbol representation	
Initial symbols	Material heat-treatment symbols	TS-	Bearing for high temperature application which was heat-treated for dimensional stabilization
		M-	Plated bearing
		E-	Bearing made of case-hardened steel
F-		Bearing made of stainless steel	
H-		Bearing made of high speed steel	
C-		Bearing made of carbon steel	
Expansion compensation	EC-	Expansion-compensated bearing	
Basic symbols			
Tail codes	Internal construction symbols	ZW	Double-row cage
		A,B,C	Internal construction change
	Cage symbols	J	Steel plate punched cage
		F1	Machined iron cage
		L1	High-strength yellow copper cage
		T2	Polyamide resin cage
		L3	Aluminum alloy cage
		L5	Sintered alloy cage
	S	Welded cage	
	Seal symbols	L,LL	With synthetic rubber seal
		P,PP	With plastic seal
	Bearing ring profile symbols	K	Bearing with 1/12 tapered bore
		N	Grooved snap ring
NR		With snap ring	
W		Bearing ring with notched knock hole	
D		With oil hole	
D1		With oil hole and oil groove	
H	Cam follower with hexagon hole		
Combination symbols	D2,Dn	Complex bearing using two or more same bearings	
	+α	With spacer	
	-P	Without cross roller stud	
Clearance symbols	C2	Clearance smaller than ordinary clearance	
	C3	Clearance larger than ordinary clearance	
	C4	Radial clearance larger than C3	
	NA	Non-interchangeable clearance	
Accuracy class symbols	P6	Bearing of JIS Class-6	
	P5	Bearing of JIS Class-5	
	P4	Bearing of JIS Class-4	
Lubrication symbols	/2A	SHELL ALVANIA Grease 2	
	/3A	SHELL ALVANIA Grease 3	
Special symbols	V1~Vn	Special specification, requirements	

Needle Roller Bearings

BEARING TABLES

Needle roller and cage assemblies	B- 3~ 20
Needle roller and cage assemblies for connecting rod bearings	B- 21~ 28
Drawn cup needle roller bearings	B- 29~ 52
Machined-ring needle roller bearings	B- 53~ 96
Machined-ring needle roller bearings, separable	B- 97~114
Inner rings	B-115~132
Clearance-adjustable needle roller bearings	B-133~138
Complex bearings	B-139~160
Roller followers	B-161~173
Cam followers	B-174~204
Thrust roller bearings	B-205~220
Components Needle rollers / Snap rings / Seals	B-221~234
Linear bearings	B-235~254
One-way clutches	B-255~259
Bottom roller bearings for textile machinery Tension pulleys for textile machinery	B-260~266

Needle Roller and Cage Assemblies

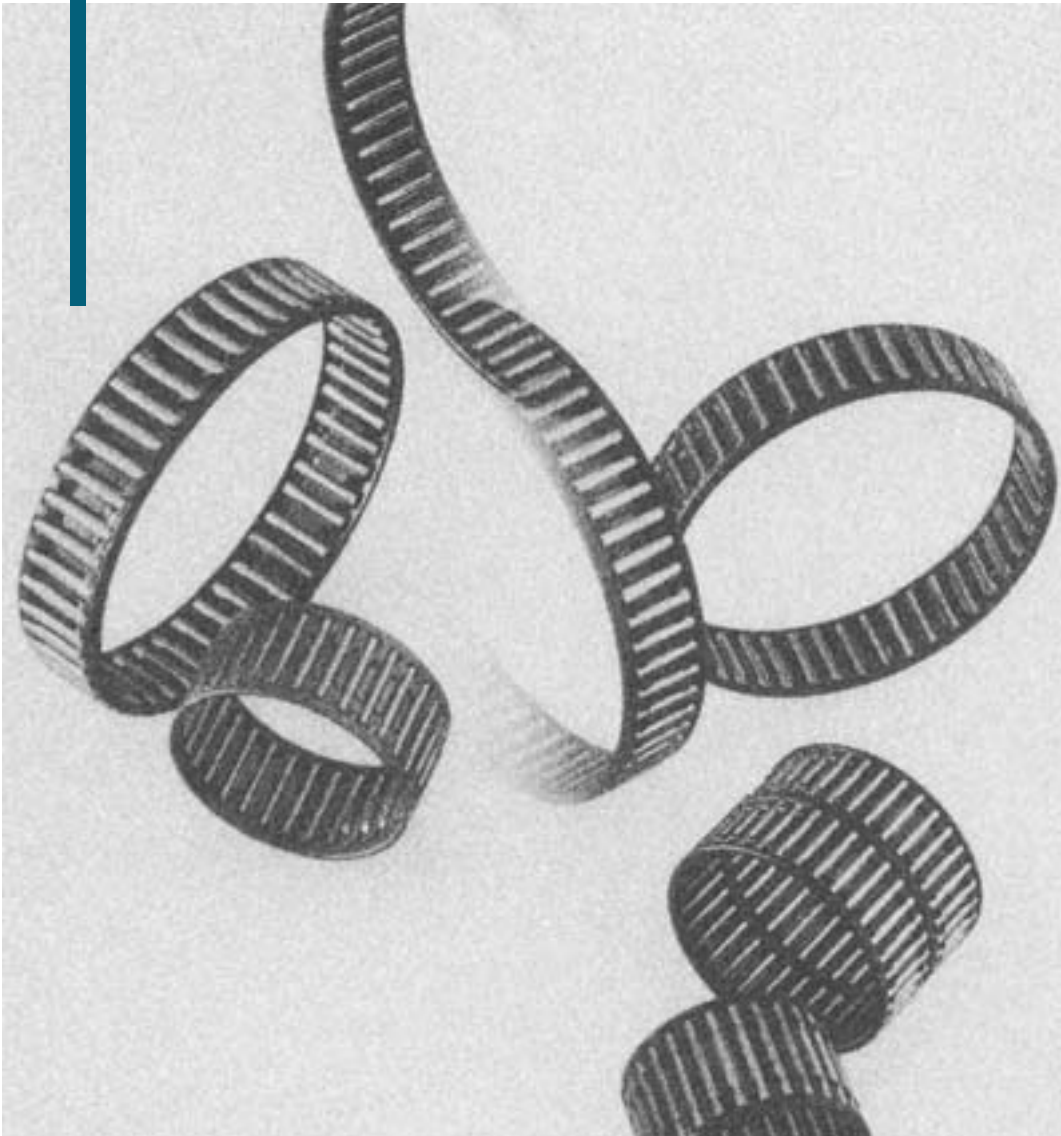

Needle Roller and Cage Assemblies

This needle roller and cage assembly is one of the basic components for the needle roller bearing of a construction wherein the needle rollers are fitted with a cage so as not to separate from each other. The use of this roller and cage assembly enables to design a compact and lightweight construction by utilizing a shaft

or a housing as the direct raceway surface, without using inner ring and outer ring.

The needle rollers are guided by the cage more precisely than the full complement roller type, hence enabling high speed running of bearing. In addition, its rigidity and load capacity are high for the specific space.

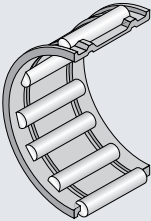
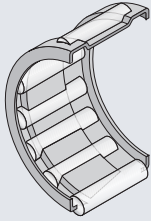
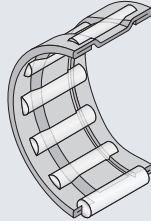
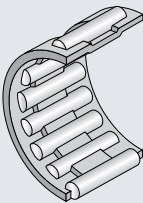
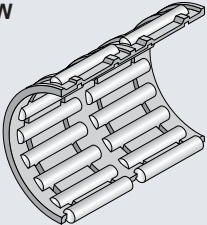
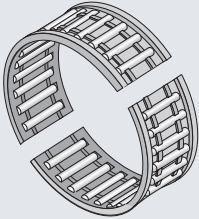
Type of needle roller and cage assembly	Cage type	Applied shaft diameter (mm)	Composition of nominal bearing number	Nominal bearing number	Code items and respective dimensions
K (K·S) (K·T2) 	Machined ring type Polyamide resin type	$\phi 3 \sim \phi 285$	K 20 × 24 × 10 S Inscribed circle diameter Roller set outer diameter Width Tail code Type code	K20×24×10S	Inscribed circle diameter : $\phi 20$ Roller set outer diameter : $\phi 24$ Width : 10 S : Welded type
	Welded type	$\phi 10 \sim \phi 100$			
KMJ (KMJ·S) (PCJ) 	Punched type	$\phi 15 \sim \phi 100$	KMJ 20 × 26 × 13 Inscribed circle diameter Roller set outer diameter Width Type code	KMJ20×26×13	Inscribed circle diameter : $\phi 20$ Roller set outer diameter : $\phi 26$ Width : 13
	Welded type	$\phi 10 \sim \phi 40$			
KJ·S 	Welded type	$\phi 20 \sim \phi 40$	KJ 30 × 35 × 17 S Inscribed circle diameter Roller set outer diameter Width Tail code Type code	KJ30×35×17S	Inscribed circle diameter : $\phi 30$ Roller set outer diameter : $\phi 35$ Width : 17 S : Welded type
KV·S 	Welded type	$\phi 7 \sim \phi 100$	KV 30 × 35 × 17 S Inscribed circle diameter Roller set outer diameter Width Tail code Type code	KV30×35×17S	Inscribed circle diameter : $\phi 30$ Roller set outer diameter : $\phi 35$ Width : 17 S : Welded type
K·ZW 	Machined ring type	$\phi 8 \sim \phi 285$	K 20 × 24 × 45 ZW Inscribed circle diameter Roller set outer diameter Width Tail code Type code	K20×24×45ZW	Inscribed circle diameter : $\phi 20$ Roller set outer diameter : $\phi 24$ Width : 45 ZW : Double-row type
GK 	Machined ring type Split type	$\phi 8 \sim \phi 285$	GK 30 × 35 × 17 Inscribed circle diameter Roller set outer diameter Width Type code	GK30×35×17	Inscribed circle diameter : $\phi 30$ Roller set outer diameter : $\phi 35$ Width : 17

The ones with tail code T2 using polyamide resin cage shall be used at allowable temperature 120°C and, under continuous running, at 100°C or less.

The applied shaft diameter of welded type are described based on size that manufacturers can deal with a manufacturing. Therefore, it has nothing to do with the Demention Table.

Inter-roller diameter deviation of needle rollers

Inter-roller diameter deviation of needle rollers which are built in one cage is within 2μm. The respective specified diameter tolerances for built-in needle rollers are identified by identification colors on the package label, as shown in **Table 1**.

The standard identification colors marked on each label are red, dark blue, blue, black and white, unless otherwise specially indicated.

Where two or more bearings are used in tandem, those of same identification color must be used for equal distribution of bearing load.

Table 1 Color identification of diameter tolerances for needle roller bearings

Identification color on label	Diameter tolerance μm	Classification
Red	0~ - 2	Standard
Dark blue	-1~ - 3	
Blue	-2~ - 4	
Black	-3~ - 5	
White	-4~ - 6	
Gray	-5~ - 7	Semi-standard
Green	-6~ - 8	
Brown	-7~ - 9	
Yellow	-8~ - 10	

Radial Clearance

When a shaft and a housing are used as the direct raceway surface, the radial clearance is determined by the shaft diameter and the housing hole dimension. Where the diameter tolerances for needle rollers are standard (tolerances color-identified in red, dark blue, blue, black, white), the shaft diameters and housing hole dimensions shown in **Table 2** are used.

Table 2 Recommended fits

Shaft diameter mm		~80	80~140	140~
Radial clearance	Smaller than ordinary clearance	j5/G6	h5/G6	h5/G6
	Ordinary clearance	h5/G6	g5/G6	f5/H6
	Larger than ordinary clearance	g6/G6	f6/G6	f6/G6

Shaft and housing specifications

Where a shaft and a housing are used as the direct raceway surface, the raceway surface must meet the specifications described in **Table 3**.

Table 3 Shaft and housing specifications

Characteristics	Shaft	Housing
Roundness (max)	IT3	IT4
Cylindricity (max)	IT3	IT4
Surface roughness (max)	Refer to Table 7.4 on page A-39.	
Surface hardness	HRC58~64	
Depth of hardened layer (min)	Refer to formula (7.1) on page A-39	

Bearing installation related dimensions

The tolerances for the nominal dimension "Bc" of cage specified in **Table 4** are recommended as the guide width b of cage.

Table 4 Guide width tolerances

Unit : mm

Classification	Tolerances for guide width <i>b</i>	
	Single row	Double row
Metric system	$B_c \begin{smallmatrix} +0.2 \\ 0 \end{smallmatrix}$	$B_c \begin{smallmatrix} +0.3 \\ +0.1 \end{smallmatrix}$
Inch system	$B_c \begin{smallmatrix} \pm 0.4 \\ \pm 0.2 \end{smallmatrix}$	$B_c \begin{smallmatrix} \pm 0.5 \\ \pm 0.3 \end{smallmatrix}$

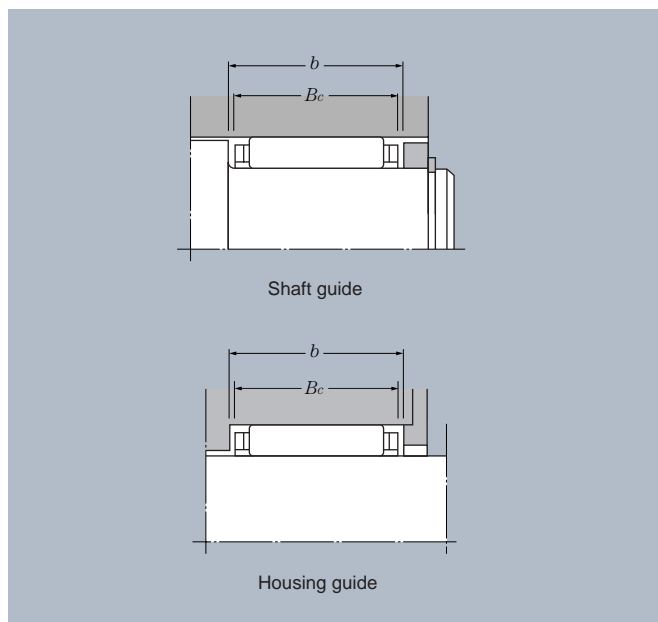
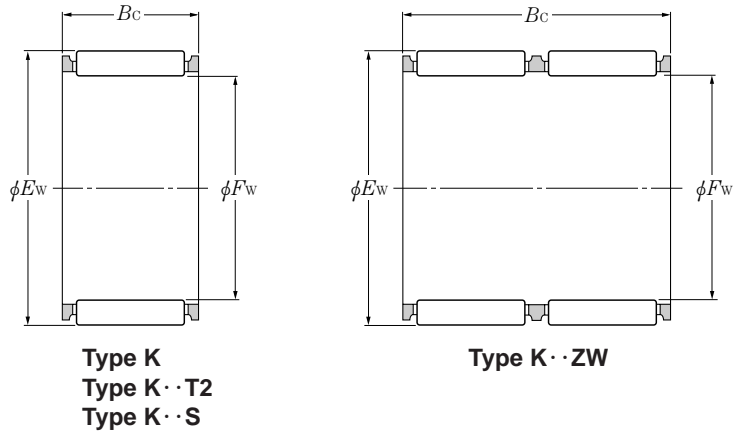

Fig. 1

Type K
Type K··T2
Type K··S
Type K··ZW
Type KMJ



F_w 3~12mm

Boundary dimensions			Basic load ratings				Limiting speeds		Bearing numbers	Mass
mm			dynamic	static	dynamic	static	r/min			kg
F_w	E_w	B_c	N		kgf		grease	oil		(approx.)
			C_r	C_{or}	C_r	C_{or}				
3	6	7 ^{-0.2} _{-0.55}	1 460	970	149	99	33 000	50 000	K3×6×7T2	0.0004
4	7	7 ^{-0.2} _{-0.55}	1 770	1 270	180	129	30 000	45 000	K4×7×7T2	0.0005
5	8	8 ^{-0.2} _{-0.55}	2 640	2 190	269	224	27 000	40 000	K5×8×8T2	0.0007
	8	10 ^{-0.2} _{-0.55}	2 720	2 250	277	230	27 000	40 000	K5×8×10T2	0.0009
6	9	8	2 660	2 280	272	233	25 000	37 000	K6×9×8T2	0.0009
	9	10 ^{-0.2} _{-0.55}	3 400	3 150	345	320	25 000	37 000	K6×9×10T2	0.0011
	10	13	4 400	3 700	450	380	25 000	37 000	K6×10×13T2	0.0019
7	10	8 ^{-0.2} _{-0.55}	2 670	2 350	272	239	23 000	34 000	K7×10×8T2	0.0009
	10	10 ^{-0.2} _{-0.55}	3 400	3 200	345	330	23 000	34 000	K7×10×10T2	0.0011
8	11	8	3 150	3 000	320	305	21 000	32 000	K8×11×8T2	0.0011
	11	10	4 000	4 100	410	420	21 000	32 000	K8×11×10T2	0.0013
	11	13 ^{-0.2} _{-0.55}	4 850	5 200	495	535	21 000	32 000	K8×11×13	0.0026
	12	10 ^{-0.2} _{-0.55}	4 650	4 150	475	425	21 000	32 000	K8×12×10T2	0.0020
	12	12	5 600	5 300	570	540	21 000	32 000	K8×12×12	0.0034
9	12	13	5 600	5 300	570	540	21 000	32 000	K8×12×13	0.0036
	12	10 ^{-0.2} _{-0.55}	4 550	5 000	465	510	20 000	30 000	K9×12×10T2	0.0015
10	12	13 ^{-0.2} _{-0.55}	5 500	6 400	560	650	20 000	30 000	K9×12×13T2	0.0021
	13	10	4 550	5 100	460	520	19 000	28 000	K10×13×10T2	0.0016
11	13	13	5 450	6 450	555	660	19 000	28 000	K10×13×13	0.0031
	14	8 ^{-0.2} _{-0.55}	4 300	3 950	435	405	19 000	28 000	K10×14×8	0.0027
	14	10 ^{-0.2} _{-0.55}	5 500	5 450	560	555	19 000	28 000	K10×14×10	0.0034
	14	13	6 600	6 900	675	705	19 000	28 000	K10×14×13	0.0044
	16	12	7 100	5 950	720	610	19 000	28 000	K10×16×12	0.0066
11	14	10 ^{-0.2} _{-0.55}	5 050	6 000	515	615	18 000	27 000	K11×14×10	0.0028
12	15	9	4 450	5 250	455	535	17 000	26 000	K12×15×9	0.0027
	15	10	5 000	6 100	510	620	17 000	26 000	K12×15×10S	0.0033
	15	13 ^{-0.2} _{-0.55}	6 000	7 700	615	785	17 000	26 000	K12×15×13	0.0038
	15	20	8 550	12 200	875	1 240	17 000	26 000	K12×15×20ZW	0.0059
	16	8	4 850	4 900	495	500	17 000	26 000	K12×16×8	0.0034

Remarks: Even when an order is placed with reference to "Nominal bearing number" listed in this table, the ordered bearings are subject to being delivered with different cage type.

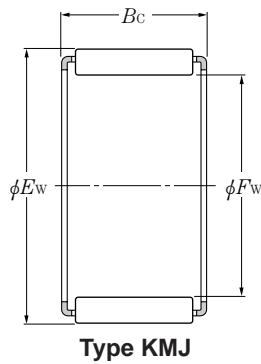

F_w 12~16mm

Boundary dimensions			Basic load ratings				Limiting speeds		Bearing numbers	Mass
mm			dynamic	static	dynamic	static	r/min		kg (approx.)	
F_w	E_w	B_c	N		kgf		grease	oil		
			C_r	C_{or}	C_r	C_{or}				
12	16	13	7 500	8 500	765	870	17 000	26 000	K12×16×13	0.0055
	17	13 ^{-0.2} _{-0.55}	9 000	9 400	920	960	17 000	26 000	K12×17×13	0.0075
	18	12	8 650	8 000	880	815	17 000	26 000	K12×18×12	0.0084
14	17	10	5 400	7 050	550	720	16 000	24 000	K14×17×10	0.0033
	18	10	6 900	8 000	705	815	16 000	24 000	K14×18×10	0.0046
	18	11	7 600	9 050	775	925	16 000	24 000	K14×18×11	0.0053
	18	13	8 300	10 100	845	1 030	16 000	24 000	K14×18×13	0.0063
	18	15 ^{-0.2} _{-0.55}	9 650	12 300	985	1 250	16 000	24 000	K14×18×15S	0.0076
	18	17	10 900	14 400	1 120	1 470	16 000	24 000	K14×18×17	0.0081
	18	39	18 800	28 900	1 910	2 950	16 000	24 000	K14×18×39ZW	0.0180
	19	13	8 950	9 650	915	985	16 000	24 000	K14×19×13	0.0080
	20	12	9 350	9 150	955	930	16 000	24 000	K14×20×12	0.0095
20	17	13 500	14 600	1 370	1 490	16 000	24 000	K14×20×17	0.0140	
15	18	14	7 850	11 600	800	1 190	15 000	23 000	K15×18×14	0.0060
	19	10	6 850	8 050	700	820	15 000	23 000	K15×19×10S	0.0051
	19	13	8 250	10 200	840	1 040	15 000	23 000	K15×19×13S	0.0067
	19	17	10 900	14 600	1 110	1 490	15 000	23 000	K15×19×17	0.0090
	19	24 ^{-0.2} _{-0.55}	14 100	20 400	1 440	2 080	15 000	23 000	K15×19×24ZW	0.0130
	20	13	10 100	11 500	1 030	1 170	15 000	23 000	K15×20×13	0.0088
	21	15	11 900	12 500	1 210	1 280	15 000	23 000	K15×21×15	0.0130
	21	17	15 100	17 200	1 540	1 750	15 000	23 000	KMJ15×21×17	0.0140
	21	21	16 500	19 100	1 680	1 950	15 000	23 000	K15×21×21	0.0170
16	20	10	7 500	9 250	765	945	15 000	23 000	K16×20×10	0.0057
	20	11	8 300	10 500	845	1 070	15 000	23 000	K16×20×11	0.0061
	20	13	9 050	11 800	925	1 200	15 000	23 000	K16×20×13	0.0071
	20	17 ^{-0.2} _{-0.55}	11 900	16 800	1 220	1 710	15 000	23 000	K16×20×17S	0.0092
	22	12	11 700	12 500	1 190	1 280	15 000	23 000	K16×22×12	0.0100
	22	13	12 600	13 900	1 290	1 410	15 000	23 000	KMJ16×22×13	0.0110
	22	16	14 200	16 100	1 450	1 650	15 000	23 000	KMJ16×22×16	0.0140
	22	17	14 400	16 400	1 470	1 670	15 000	23 000	K16×22×17	0.0150

Remarks: Even when an order is placed with reference to "Nominal bearing number" listed in this table, the ordered bearings are subject to being delivered with different cage type.

Type K
Type K··S
Type K··ZW
Type KMJ
Type KMJ··S

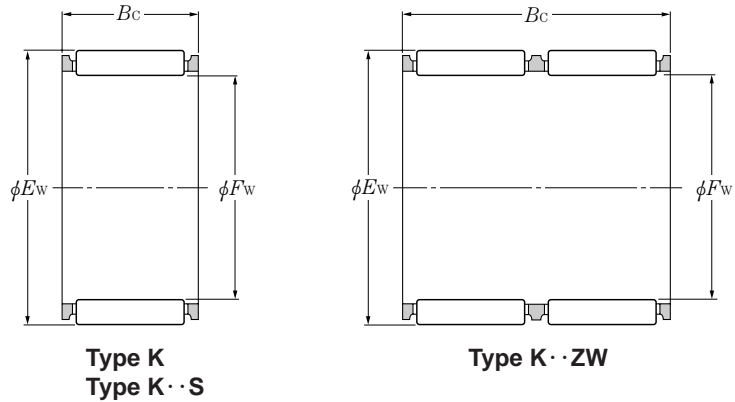

F_w 16~20mm

Boundary dimensions			Basic load ratings				Limiting speeds		Bearing numbers	Mass
mm			dynamic	static	dynamic	static	r/min			kg
F_w	E_w	B_c	N		kgf		grease	oil		(approx.)
16	22	20 ^{-0.2} _{-0.55}	16 000	18 800	1 640	1 920	15 000	23 000	K16×22×20	0.0170
	21	10	7 450	9 300	760	950	15 000	22 000	K17×21×10S	0.0056
17	21	13	9 400	12 600	960	1 280	15 000	22 000	K17×21×13S	0.0075
	21	15 ^{-0.2} _{-0.55}	10 400	14 400	1 060	1 460	15 000	22 000	K17×21×15	0.0089
	21	17	11 800	16 900	1 210	1 720	15 000	22 000	K17×21×17	0.0095
	22	20	14 700	19 200	1 500	1 960	15 000	22 000	K17×22×20	0.0150
	23	17	14 400	16 500	1 460	1 690	15 000	22 000	K17×23×17	0.0160
18	22	10	7 400	9 400	755	955	14 000	21 000	K18×22×10	0.0061
	22	13	8 900	11 900	910	1 210	14 000	21 000	K18×22×13	0.0077
	22	17	11 700	17 000	1 200	1 730	14 000	21 000	K18×22×17	0.0110
	23	20	14 600	19 300	1 490	1 970	14 000	21 000	K18×23×20S	0.0150
	24	12 ^{-0.2} _{-0.55}	12 300	13 800	1 250	1 410	14 000	21 000	K18×24×12	0.0120
	24	13	11 600	12 800	1 180	1 300	14 000	21 000	K18×24×13	0.0130
	24	17	16 000	19 300	1 630	1 970	14 000	21 000	KMJ18×24×17S	0.0140
	24	20	17 000	20 900	1 730	2 130	14 000	21 000	K18×24×20	0.0190
	25	17	18 000	20 400	1 830	2 080	14 000	21 000	K18×25×17	0.0190
25	22	22 100	26 600	2 250	2 710	14 000	21 000	K18×25×22	0.0240	
19	23	13 ^{-0.2} _{-0.55}	9 650	13 500	985	1 370	14 000	21 000	K19×23×13	0.0082
	23	17	12 700	19 200	1 300	1 960	14 000	21 000	K19×23×17	0.0110
20	24	10	8 300	11 200	845	1 150	13 000	20 000	K20×24×10S	0.0065
	24	11	9 500	13 400	970	1 370	13 000	20 000	K20×24×11	0.0072
	24	13	10 000	14 300	1 020	1 460	13 000	20 000	K20×24×13S	0.0086
	24	17	13 200	20 400	1 340	2 080	13 000	20 000	K20×24×17S	0.0110
	24	45	16 400	27 100	1 680	2 760	13 000	20 000	K20×24×45ZW	0.0280
	25	40 ^{-0.2} _{-0.55}	29 000	48 000	2 950	4 900	13 000	20 000	K20×25×40ZW	0.0330
	26	12	12 900	15 100	1 320	1 540	13 000	20 000	K20×26×12	0.0130
	26	13	14 000	16 700	1 420	1 700	13 000	20 000	KMJ20×26×13	0.0120
	26	17	17 800	22 800	1 810	2 330	13 000	20 000	KMJ20×26×17S	0.0160
	26	20	20 600	27 600	2 100	2 820	13 000	20 000	KMJ20×26×20S	0.0190
28	25	27 100	32 500	2 760	3 300	13 000	20 000	K20×28×25	0.0370	

Remarks: Even when an order is placed with reference to "Nominal bearing number" listed in this table, the ordered bearings are subject to being delivered with different cage type.

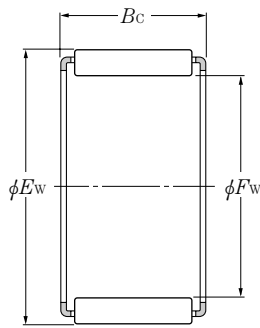

Type KMJ
Type KMJ · S

F_w 21~25mm

	Boundary dimensions			Basic load ratings				Limiting speeds		Bearing numbers	Mass kg (approx.)
	mm			dynamic	static	dynamic	static	r/min			
	F_w	E_w	B_c	N		kgf		grease	oil		
			C_r	C_{or}	C_r	C_{or}					
21	25	13	$_{-0.2}$	10 300	15 100	1 050	1 540	13 000	19 000	K21×25×13	0.0090
	25	17	$_{-0.55}$	13 600	21 500	1 380	2 200	13 000	19 000	K21×25×17	0.0120
22	26	10		8 500	11 900	865	1 220	12 000	18 000	K22×26×10S	0.0071
	26	11		10 100	14 900	1 030	1 520	12 000	18 000	K22×26×11S	0.0079
	26	13		10 200	15 200	1 040	1 550	12 000	18 000	K22×26×13	0.0094
	26	17		13 500	21 600	1 370	2 200	12 000	18 000	K22×26×17S	0.0120
	27	20	$_{-0.2}$	17 500	25 900	1 780	2 640	12 000	18 000	K22×27×20	0.0200
	27	40	$_{-0.55}$	29 900	51 500	3 050	5 250	12 000	18 000	K22×27×40ZW	0.0390
	28	17		17 700	23 300	1 810	2 380	12 000	18 000	K22×28×17	0.0200
	29	16		18 700	22 700	1 910	2 310	12 000	18 000	KMJ22×29×16	0.0220
30	15		19 300	21 700	1 970	2 210	12 000	18 000	K22×30×15	0.0220	
23	28	24	$_{-0.2}$ $_{-0.55}$	19 800	31 000	2 020	3 150	11 000	17 000	K23×28×24	0.0230
24	28	10		9 000	13 200	915	1 350	11 000	17 000	K24×28×10S	0.0081
	28	13		10 800	16 800	1 100	1 710	11 000	17 000	K24×28×13	0.0100
	28	17	$_{-0.2}$	14 300	23 900	1 460	2 440	11 000	17 000	K24×28×17	0.0130
	29	13	$_{-0.55}$	12 300	16 900	1 250	1 720	11 000	17 000	K24×29×13	0.0120
	30	17		18 400	25 200	1 880	2 570	11 000	17 000	K24×30×17	0.0220
	30	31		27 900	43 000	2 840	4 350	11 000	17 000	K24×30×31ZW	0.0390
25	29	10		8 950	13 300	910	1 350	11 000	16 000	K25×29×10	0.0083
	29	13		10 800	16 900	1 100	1 720	11 000	16 000	K25×29×13	0.0100
	29	17		14 200	24 000	1 450	2 450	11 000	16 000	K25×29×17S	0.0140
	30	13		13 200	18 800	1 350	1 920	11 000	16 000	K25×30×13	0.0130
	30	17		17 400	26 800	1 770	2 730	11 000	16 000	K25×30×17S	0.0170
	30	20	$_{-0.2}$	19 400	31 000	1 980	3 150	11 000	16 000	K25×30×20S	0.0210
	30	26	$_{-0.55}$	21 800	35 500	2 220	3 650	11 000	16 000	K25×30×26ZW	0.0270
	30	39		29 800	53 500	3 050	5 450	11 000	16 000	K25×30×39ZW	0.0400
	31	13		15 200	19 900	1 550	2 030	11 000	16 000	K25×31×13	0.0160
	31	14		16 500	22 100	1 680	2 250	11 000	16 000	K25×31×14	0.0180
	31	17		18 300	25 300	1 870	2 580	11 000	16 000	K25×31×17	0.0220
31	21		22 500	33 000	2 290	3 350	11 000	16 000	K25×31×21	0.0260	

Remarks: Even when an order is placed with reference to "Nominal bearing number" listed in this table, the ordered bearings are subject to being delivered with different cage type.

- Type K
- Type K··S
- Type K··ZW
- Type KMJ
- Type KMJ··S
- Type KJ··S

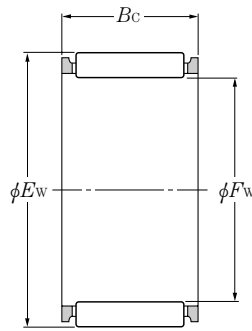

Type K
Type K··S

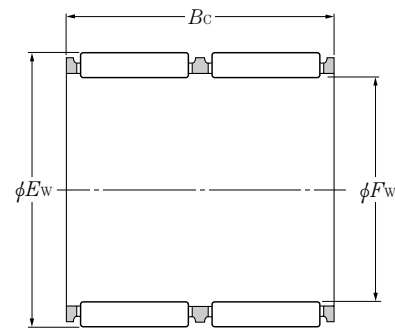

Type K··ZW

F_w 25~32mm

Boundary dimensions	Basic load ratings						Limiting speeds		Bearing numbers	Mass kg (approx.)	
	mm			dynamic	static	dynamic	static	r/min			
	F_w	E_w	B_c	N		kgf		grease			oil
			C_r	C_{or}	C_r	C_{or}					
25	32	16	$_{-0.2}^{-0.55}$	19 500	24 700	1 990	2 520	11 000	16 000	KMJ25×32×16	0.025
	33	24	$_{-0.2}^{-0.55}$	34 500	47 000	3 500	4 800	11 000	16 000	KMJ25×33×24S	0.040
26	30	13		11 800	19 200	1 200	1 960	10 000	15 000	K26×30×13	0.011
	30	17	$_{-0.2}^{-0.55}$	15 500	27 400	1 580	2 790	10 000	15 000	K26×30×17	0.015
	34	22		24 200	30 000	2 470	3 050	10 000	15 000	K26×34×22	0.041
28	32	17		15 300	27 500	1 560	2 810	9 500	14 000	K28×32×17	0.017
	32	21		18 700	35 500	1 910	3 650	9 500	14 000	K28×32×21	0.020
	33	13		13 900	20 900	1 420	2 130	9 500	14 000	K28×33×13	0.015
	33	17		18 300	29 800	1 870	3 050	9 500	14 000	K28×33×17S	0.020
	33	26	$_{-0.2}^{-0.55}$	23 900	42 000	2 430	4 250	9 500	14 000	K28×33×26ZW	0.033
	33	27	$_{-0.2}^{-0.55}$	28 300	52 000	2 890	5 300	9 500	14 000	K28×33×27	0.032
	34	14		17 500	24 800	1 790	2 530	9 500	14 000	K28×34×14	0.020
	34	17		18 100	25 800	1 850	2 630	9 500	14 000	K28×34×17	0.024
	35	16		21 200	28 400	2 160	2 900	9 500	14 000	K28×35×16	0.029
35	18		21 500	28 900	2 190	2 950	9 500	14 000	K28×35×18	0.031	
29	34	17	$_{-0.2}^{-0.55}$	18 900	31 000	1 920	3 200	9 500	14 000	K29×34×17S	0.022
	34	27	$_{-0.2}^{-0.55}$	28 100	52 000	2 870	5 300	9 500	14 000	K29×34×27	0.033
30	35	11		12 200	18 000	1 240	1 840	8 500	13 000	K30×35×11S	0.014
	35	13		14 700	22 900	1 500	2 340	8 500	13 000	K30×35×13S	0.016
	35	17		19 400	32 500	1 970	3 350	8 500	13 000	KJ30×35×17S	0.021
	35	20		21 600	37 500	2 200	3 850	8 500	13 000	K30×35×20S	0.025
	35	26		25 200	46 000	2 570	4 650	8 500	13 000	K30×35×26ZW	0.032
	35	27	$_{-0.2}^{-0.55}$	29 900	57 000	3 050	5 800	8 500	13 000	K30×35×27S	0.033
	36	14	$_{-0.2}^{-0.55}$	18 600	27 400	1 900	2 790	8 500	13 000	KMJ30×36×14	0.022
	37	16		21 900	30 500	2 230	3 100	8 500	13 000	K30×37×16	0.029
	37	18		23 300	33 000	2 370	3 350	8 500	13 000	K30×37×18	0.034
	37	20		26 200	38 000	2 670	3 850	8 500	13 000	KMJ30×37×20	0.038
	37	48		40 000	65 500	4 050	6 700	8 500	13 000	K30×37×48ZW	0.075
	38	18		25 000	33 000	2 550	3 350	8 500	13 000	K30×38×18	0.036
32	36	15	$_{-0.2}^{-0.55}$	14 300	26 400	1 460	2 700	8 500	13 000	K32×36×15S	0.017

Remarks: Even when an order is placed with reference to "Nominal bearing number" listed in this table, the ordered bearings are subject to being delivered with different cage type.

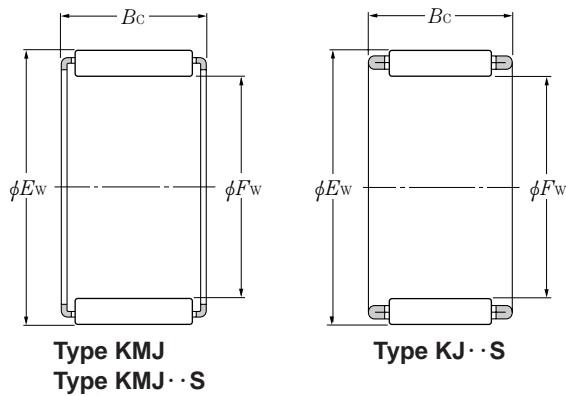

F_w 32~38mm

Boundary dimensions			Basic load ratings				Limiting speeds		Bearing numbers	Mass
mm			dynamic	static	dynamic	static	r/min		kg (approx.)	
F_w	E_w	B_c	N		kgf		grease	oil		
			C_r	C_{or}	C_r	C_{or}				
32	37	13	14 500	23 000	1 480	2 350	8 500	13 000	K32×37×13	0.018
	37	17	19 200	33 000	1 950	3 350	8 500	13 000	K32×37×17S	0.022
	37	26	24 900	46 000	2 540	4 700	8 500	13 000	K32×37×26ZW	0.034
	37	27	29 600	57 500	3 000	5 850	8 500	13 000	KJ32×37×27S	0.037
	38	14	19 800	30 500	2 020	3 100	8 500	13 000	KMJ32×38×14	0.022
	38	20 ^{-0.2} _{-0.55}	25 100	41 000	2 560	4 150	8 500	13 000	KJ32×38×20S	0.031
	38	26	31 500	54 000	3 200	5 550	8 500	13 000	K32×38×26	0.041
	39	16	22 600	32 000	2 310	3 300	8 500	13 000	K32×39×16	0.034
	39	18	24 000	35 000	2 450	3 550	8 500	13 000	K32×39×18	0.037
	39	20	26 800	40 000	2 740	4 100	8 500	13 000	KJ32×39×20S	0.041
35	40	13	15 200	25 100	1 550	2 560	7 500	11 000	K35×40×13	0.019
	40	17	20 000	36 000	2 040	3 650	7 500	11 000	K35×40×17	0.025
	40	26	26 100	50 000	2 660	5 100	7 500	11 000	K35×40×26ZW	0.037
	40	27	32 000	65 000	3 250	6 600	7 500	11 000	KJ35×40×27S	0.039
	40	30	26 100	50 000	2 660	5 100	7 500	11 000	K35×40×30ZW	0.043
	41	14	19 400	30 500	1 980	3 100	7 500	11 000	K35×41×14	0.026
	41	15 ^{-0.2} _{-0.55}	20 900	33 500	2 130	3 400	7 500	11 000	K35×41×15	0.027
	41	40	43 000	84 000	4 400	8 550	7 500	11 000	K35×41×40ZW	0.055
	42	16	24 100	36 000	2 450	3 650	7 500	11 000	K35×42×16	0.035
	42	18	24 700	37 000	2 510	3 750	7 500	11 000	K35×42×18	0.039
	42	20	28 500	44 500	2 910	4 550	7 500	11 000	K35×42×20	0.041
	42	30	39 500	68 000	4 050	6 950	7 500	11 000	K35×42×30	0.062
	42	45	42 500	74 000	4 300	7 550	7 500	11 000	K35×42×45ZW	0.106
36	42	46 ^{-0.2} _{-0.55}	51 000	106 000	5 200	10 800	7 500	11 000	K36×42×46ZW	0.086
37	42	13	15 900	27 100	1 620	2 770	7 500	11 000	K37×42×13	0.021
	42	17 ^{-0.2} _{-0.55}	20 400	37 500	2 080	3 800	7 500	11 000	KJ37×42×17S	0.026
	42	27	32 500	67 500	3 300	6 900	7 500	11 000	KJ37×42×27S	0.041
	44	18	26 300	41 000	2 680	4 150	7 500	11 000	K37×44×18	0.042
38	43	17 ^{-0.2} _{-0.55}	20 900	38 500	2 130	3 950	7 500	11 000	K38×43×17	0.026
	43	27	32 000	67 500	3 300	6 900	7 500	11 000	K38×43×27	0.043

Remarks: Even when an order is placed with reference to "Nominal bearing number" listed in this table, the ordered bearings are subject to being delivered with different cage type.

Type K
Type K··ZW
Type KMJ
Type KJ··S

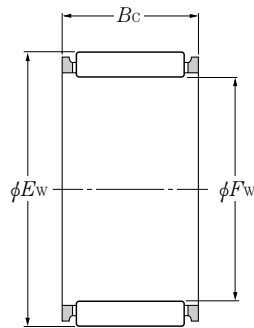

Type K

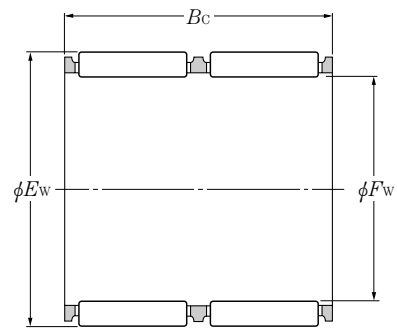

Type K··ZW

F_w 38~48mm

Boundary dimensions			Basic load ratings				Limiting speeds		Bearing numbers	Mass
mm			dynamic	static	dynamic	static	r/min			kg
F_w	E_w	B_c	N		kgf		grease	oil		(approx.)
			C_r	C_{or}	C_r	C_{or}				
38	46	20 ^{-0.2}	34 000	52 000	3 450	5 350	7 500	11 000	KMJ38×46×20	0.046
	46	32 ^{-0.55}	54 000	95 500	5 500	9 700	7 500	11 000	K38×46×32	0.073
40	45	13	16 500	29 200	1 680	2 980	6 500	10 000	K40×45×13	0.022
	45	17	21 800	41 500	2 220	4 250	6 500	10 000	K40×45×17	0.027
	45	21	26 700	54 000	2 720	5 500	6 500	10 000	K40×45×21	0.037
	45	27	33 500	72 500	3 400	7 400	6 500	10 000	K40×45×27	0.044
	46	17 ^{-0.2}	24 600	43 000	2 500	4 350	6 500	10 000	K40×46×17	0.030
	47	18 ^{-0.55}	27 700	45 000	2 820	4 550	6 500	10 000	K40×47×18	0.045
	47	20	31 000	51 500	3 150	5 250	6 500	10 000	K40×47×20	0.048
	48	20	33 000	51 000	3 350	5 200	6 500	10 000	K40×48×20	0.052
42	48	25	42 500	71 000	4 350	7 250	6 500	10 000	K40×48×25	0.065
	47	17	22 100	43 000	2 250	4 400	6 500	9 500	K42×47×17	0.028
	47	27 ^{-0.2}	34 000	75 500	3 450	7 700	6 500	9 500	K42×47×27	0.047
	48	17 ^{-0.55}	25 700	46 000	2 630	4 700	6 500	9 500	K42×48×17	0.036
43	50	20	34 000	53 500	3 450	5 500	6 500	9 500	K42×50×20	0.054
	48	17	22 000	43 000	2 240	4 400	6 500	9 500	K43×48×17	0.029
	48	27 ^{-0.2}	34 000	75 500	3 450	7 700	6 500	9 500	K43×48×27	0.046
45	50	18 ^{-0.55}	29 100	49 000	2 960	5 000	6 500	9 500	K43×50×18	0.049
	49	19	22 100	52 000	2 260	5 300	6 000	9 000	K45×49×19	0.027
	50	17	22 800	46 000	2 330	4 700	6 000	9 000	KJ45×50×17S	0.031
	50	27	34 500	78 000	3 500	7 950	6 000	9 000	K45×50×27	0.050
	52	18 ^{-0.2}	29 700	51 000	3 000	5 200	6 000	9 000	K45×52×18	0.051
	52	21 ^{-0.55}	32 000	56 500	3 300	5 750	6 000	9 000	K45×52×21	0.061
	53	20	36 000	59 000	3 650	6 000	6 000	9 000	K45×53×20	0.062
47	53	25	46 500	82 000	4 700	8 400	6 000	9 000	K45×53×25	0.077
	53	28	49 500	90 000	5 050	9 200	6 000	9 000	KJ45×53×28S	0.078
48	52	17 ^{-0.2}	23 200	47 500	2 360	4 850	5 500	8 500	K47×52×17	0.033
	52	27 ^{-0.55}	35 500	83 000	3 650	8 450	5 500	8 500	K47×52×27	0.051
48	53	37.5 ^{-0.2}	41 500	101 000	4 200	10 300	5 500	8 500	K48×53×37.5ZW	0.072

Remarks: Even when an order is placed with reference to "Nominal bearing number" listed in this table, the ordered bearings are subject to being delivered with different cage type.

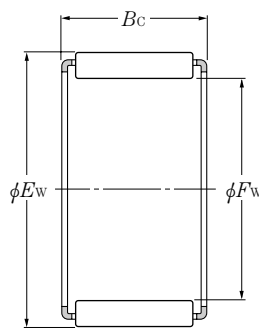

Type KMJ

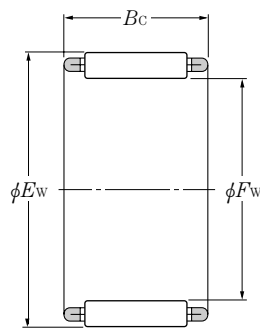

Type KJ·S

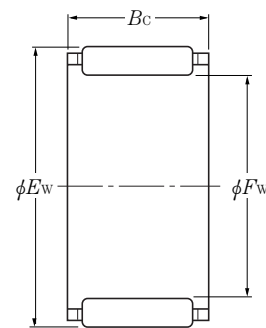

Type KV·S

F_w 48~60mm

Boundary dimensions			Basic load ratings				Limiting speeds		Bearing numbers	Mass
mm			dynamic	static	dynamic	static	r/min			kg
F_w	E_w	B_c	N		kgf		grease	oil		(approx.)
			C_r	C_{or}	C_r	C_{or}				
48	54	19 ^{-0.2} _{-0.55}	31 000	61 000	3 150	6 250	5 500	8 500	K48×54×19	0.044
	55	13.5	18 100	35 500	1 850	3 600	5 500	8 000	K50×55×13.5	0.023
	55	20	27 900	62 000	2 850	6 300	5 500	8 000	K50×55×20	0.042
	55	27	37 000	88 500	3 750	9 000	5 500	8 000	K50×55×27	0.053
	55	30 ^{-0.2} _{-0.55}	39 500	97 000	4 050	9 900	5 500	8 000	K50×55×30	0.059
	57	18	31 500	57 000	3 200	5 800	5 500	8 000	K50×57×18	0.053
	58	20	38 500	67 500	3 950	6 850	5 500	8 000	K50×58×20	0.065
50	58	25	48 500	90 000	4 950	9 150	5 500	8 000	K50×58×25	0.081
	52	19 ^{-0.2} _{-0.55}	32 000	65 500	3 250	6 650	5 000	7 500	K52×58×19	0.048
	60	17	25 800	58 000	2 630	5 900	5 000	7 500	K55×60×17	0.043
	60	20	28 800	66 500	2 940	6 750	5 000	7 500	K55×60×20	0.045
	60	30	42 000	108 000	4 300	11 000	5 000	7 500	KV55×60×30S	0.069
	61	19	33 000	69 500	3 350	7 100	5 000	7 500	K55×61×19	0.051
	61	20 ^{-0.2} _{-0.55}	33 000	69 500	3 350	7 100	5 000	7 500	K55×61×20	0.054
	61	30 ^{-0.2} _{-0.55}	48 000	113 000	4 900	11 500	5 000	7 500	K55×61×30	0.081
	62	18	33 500	63 000	3 400	6 450	5 000	7 500	K55×62×18	0.054
	63	20	39 000	70 000	3 950	7 100	5 000	7 500	K55×63×20	0.073
55	63	25	50 500	97 500	5 150	9 950	5 000	7 500	K55×63×25	0.088
	63	32	61 000	125 000	6 200	12 700	5 000	7 500	K55×63×32	0.117
	58	19 ^{-0.2} _{-0.55}	34 000	73 500	3 450	7 500	4 700	7 000	K58×64×19	0.052
	65	20	29 800	71 500	3 050	7 300	4 300	6 500	K60×65×20	0.051
	65	30	43 500	116 000	4 450	11 800	4 300	6 500	K60×65×30	0.071
	66	19	33 500	73 500	3 450	7 500	4 300	6 500	K60×66×19	0.053
	66	20	33 500	73 500	3 450	7 500	4 300	6 500	K60×66×20	0.056
	66	30 ^{-0.2} _{-0.55}	49 000	119 000	5 000	12 200	4 300	6 500	K60×66×30	0.084
	68	15 ^{-0.2} _{-0.55}	27 200	45 500	2 780	4 650	4 300	6 500	K60×68×15	0.058
	68	20	40 000	75 000	4 100	7 650	4 300	6 500	K60×68×20	0.077
	68	23	44 500	85 000	4 500	8 700	4 300	6 500	K60×68×23	0.092
	68	25	52 000	105 000	5 300	10 700	4 300	6 500	K60×68×25	0.097
60	68	27	52 000	105 000	5 300	10 700	4 300	6 500	K60×68×27	0.098

Remarks: Even when an order is placed with reference to "Nominal bearing number" listed in this table, the ordered bearings are subject to being delivered with different cage type.

Type K
Type K··ZW
Type KMJ

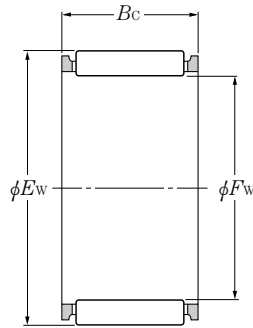

Type K

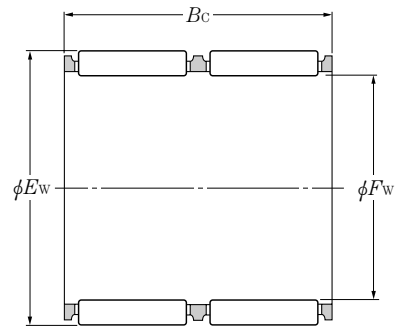

Type K··ZW

F_w 60~80mm

Boundary dimensions			Basic load ratings				Limiting speeds		Bearing numbers	Mass
mm			dynamic	static	dynamic	static	r/min			kg
F_w	E_w	B_c	N		kgf		grease	oil		(approx.)
			C_r	C_{or}	C_r	C_{or}				
60	68	30 $\begin{smallmatrix} -0.2 \\ -0.55 \end{smallmatrix}$	46 500	91 000	4 750	9 300	4 300	6 500	K60×68×30ZW	0.119
61	66	20 $\begin{smallmatrix} -0.2 \\ -0.55 \end{smallmatrix}$	29 700	71 500	3 050	7 300	4 300	6 500	K61×66×20	0.054
	66	30 $\begin{smallmatrix} -0.2 \\ -0.55 \end{smallmatrix}$	43 500	116 000	4 400	11 900	4 300	6 500	K61×66×30	0.073
63	70	21 $\begin{smallmatrix} -0.2 \\ -0.55 \end{smallmatrix}$	44 500	95 500	4 500	9 700	4 300	6 500	K63×70×21	0.075
64	70	16 $\begin{smallmatrix} -0.2 \\ -0.55 \end{smallmatrix}$	28 400	60 500	2 900	6 150	4 300	6 500	K64×70×16	0.053
65	70	20	30 500	75 000	3 100	7 650	4 000	6 000	K65×70×20	0.055
	70	30 $\begin{smallmatrix} -0.2 \\ -0.55 \end{smallmatrix}$	45 000	124 000	4 600	12 700	4 000	6 000	K65×70×30	0.083
	73	23 $\begin{smallmatrix} -0.2 \\ -0.55 \end{smallmatrix}$	47 000	94 000	4 800	9 600	4 000	6 000	K65×73×23	0.100
	73	30	61 000	132 000	6 200	13 400	4 000	6 000	K65×73×30	0.126
68	74	20	36 000	83 500	3 700	8 550	4 000	6 000	K68×74×20	0.065
	74	30 $\begin{smallmatrix} -0.2 \\ -0.55 \end{smallmatrix}$	51 500	133 000	5 250	13 500	4 000	6 000	K68×74×30	0.097
	74	35 $\begin{smallmatrix} -0.2 \\ -0.55 \end{smallmatrix}$	49 500	125 000	5 050	12 800	4 000	6 000	K68×74×35ZW	0.116
	75	21	45 500	101 000	4 600	10 300	4 000	6 000	K68×75×21	0.077
70	76	20	36 500	86 000	3 700	8 750	3 700	5 500	K70×76×20	0.070
	76	30	53 000	139 000	5 400	14 200	3 700	5 500	K70×76×30	0.100
	77	21 $\begin{smallmatrix} -0.2 \\ -0.55 \end{smallmatrix}$	45 000	101 000	4 600	10 300	3 700	5 500	K70×77×21	0.080
	78	23	49 500	103 000	5 050	10 500	3 700	5 500	K70×78×23	0.107
	78	30	65 500	149 000	6 700	15 200	3 700	5 500	K70×78×30	0.136
72	79	21 $\begin{smallmatrix} -0.2 \\ -0.55 \end{smallmatrix}$	46 500	106 000	4 750	10 800	3 700	5 500	K72×79×21	0.085
73	79	20 $\begin{smallmatrix} -0.2 \\ -0.55 \end{smallmatrix}$	39 500	95 500	4 000	9 750	3 700	5 500	KMJ73×79×20	0.063
	79	30 $\begin{smallmatrix} -0.2 \\ -0.55 \end{smallmatrix}$	54 500	146 000	5 550	14 900	3 700	5 500	K73×79×30	0.106
75	81	20	40 500	100 000	4 100	10 200	3 700	5 500	KMJ75×81×20	0.064
	81	30	56 000	152 000	5 700	15 500	3 700	5 500	K75×81×30	0.108
	82	21 $\begin{smallmatrix} -0.2 \\ -0.55 \end{smallmatrix}$	46 000	106 000	4 700	10 800	3 700	5 500	K75×82×21	0.088
	83	23	50 500	109 000	5 150	11 100	3 700	5 500	K75×83×23	0.113
	83	30	67 500	157 000	6 850	16 100	3 700	5 500	K75×83×30	0.147
80	86	20 $\begin{smallmatrix} -0.2 \\ -0.55 \end{smallmatrix}$	39 000	98 000	4 000	10 000	3 300	5 000	K80×86×20	0.077
	86	30 $\begin{smallmatrix} -0.2 \\ -0.55 \end{smallmatrix}$	57 000	159 000	5 800	16 200	3 300	5 000	K80×86×30	0.110

Remarks: Even when an order is placed with reference to "Nominal bearing number" listed in this table, the ordered bearings are subject to being delivered with different cage type.

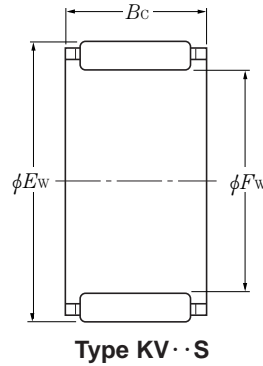
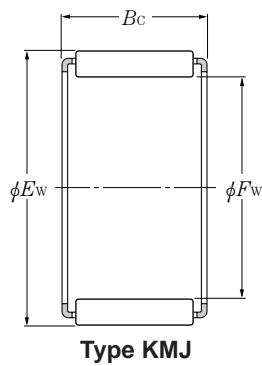

F_w 80~120mm

Boundary dimensions			Basic load ratings				Limiting speeds		Bearing numbers	Mass
mm			dynamic	static	dynamic	static	r/min			kg
F_w	E_w	B_c	N		kgf		grease	oil		(approx.)
			C_r	C_{or}	C_r	C_{or}				
80	88	23	53 000	118 000	5 400	12 100	3 300	5 000	K80×88×23	0.125
	88	26 ^{-0.2} / _{-0.55}	61 000	142 000	6 250	14 500	3 300	5 000	K80×88×26	0.131
	88	30	69 000	166 000	7 050	17 000	3 300	5 000	K80×88×30	0.157
85	92	20	47 500	115 000	4 850	11 700	3 100	4 700	KMJ85×92×20	0.083
	92	30 ^{-0.2} / _{-0.55}	66 000	176 000	6 750	18 000	3 100	4 700	K85×92×30	0.142
	93	27 ^{-0.2} / _{-0.55}	64 000	153 000	6 500	15 600	3 100	4 700	K85×93×27	0.145
	93	30	71 000	175 000	7 200	17 900	3 100	4 700	K85×93×30	0.160
90	97	20	46 000	113 000	4 700	11 500	2 900	4 400	K90×97×20	0.103
	97	30	67 500	184 000	6 850	18 700	2 900	4 400	K90×97×30	0.151
	98	26 ^{-0.2} / _{-0.55}	64 000	157 000	6 550	16 000	2 900	4 400	K90×98×26	0.148
	98	27	64 000	157 000	6 550	16 000	2 900	4 400	K90×98×27	0.150
	98	30	72 500	184 000	7 400	18 800	2 900	4 400	K90×98×30	0.172
95	102	21	48 000	122 000	4 900	12 400	2 800	4 200	K95×102×21	0.115
	102	31 ^{-0.2} / _{-0.55}	70 500	199 000	7 200	20 300	2 800	4 200	K95×102×31	0.172
	103	27 ^{-0.2} / _{-0.55}	65 500	165 000	6 700	16 800	2 800	4 200	K95×103×27	0.159
	103	30	74 000	193 000	7 550	19 600	2 800	4 200	K95×103×30	0.165
100	107	21	49 000	127 000	5 000	12 900	2 700	4 000	KV100×107×21S	0.120
	107	31 ^{-0.3} / _{-0.65}	71 500	207 000	7 300	21 100	2 700	4 000	K100×107×31	0.173
	108	27 ^{-0.3} / _{-0.65}	61 000	153 000	6 250	15 600	2 700	4 000	K100×108×27	0.176
	108	30	76 000	201 000	7 700	20 500	2 700	4 000	K100×108×30	0.190
105	112	21	48 500	127 000	4 950	12 900	2 500	3 800	K105×112×21	0.130
	112	31 ^{-0.3} / _{-0.65}	71 000	207 000	7 250	21 100	2 500	3 800	K105×112×31	0.176
	113	30	77 500	210 000	7 900	21 400	2 500	3 800	K105×113×30	0.198
110	117	24	54 500	149 000	5 550	15 200	2 400	3 600	K110×117×24	0.145
	117	34 ^{-0.3} / _{-0.65}	77 500	235 000	7 900	24 000	2 400	3 600	K110×117×34	0.205
	118	30	79 000	219 000	8 050	22 300	2 400	3 600	K110×118×30	0.217
115	123	27 ^{-0.3} / _{-0.65}	64 000	170 000	6 550	17 300	2 300	3 500	K115×123×27	0.200
	125	34 ^{-0.3} / _{-0.65}	95 000	241 000	9 700	24 600	2 300	3 500	K115×125×34	0.330
120	127	24 ^{-0.3} / _{-0.65}	57 500	165 000	5 850	16 800	2 200	3 300	K120×127×24	0.160

Remarks: Even when an order is placed with reference to "Nominal bearing number" listed in this table, the ordered bearings are subject to being delivered with different cage type.

Type K

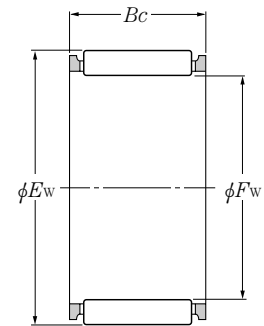

Type K

F_w 120~265mm

Boundary dimensions			Basic load ratings				Limiting speeds		Bearing numbers	Mass kg (approx.)
mm			dynamic	static	dynamic	static	r/min			
F_w	E_w	B_c	N		kgf		grease	oil		
			C_r	C_{or}	C_r	C_{or}				
120	127	34 $\begin{smallmatrix} -0.3 \\ -0.65 \end{smallmatrix}$	82 000	260 000	8 350	26 600	2 200	3 300	K120×127×34	0.235
125	133	35 $\begin{smallmatrix} -0.3 \\ -0.65 \end{smallmatrix}$	87 000	260 000	8 900	26 500	2 100	3 200	K125×133×35	0.275
	135	34 $\begin{smallmatrix} -0.3 \\ -0.65 \end{smallmatrix}$	100 000	265 000	10 200	27 000	2 100	3 200	K125×135×34	0.350
130	137	24 $\begin{smallmatrix} -0.3 \\ -0.65 \end{smallmatrix}$	59 000	175 000	6 000	17 900	2 100	3 100	K130×137×24	0.170
	137	34 $\begin{smallmatrix} -0.3 \\ -0.65 \end{smallmatrix}$	84 500	277 000	8 600	28 300	2 100	3 100	K130×137×34	0.240
135	143	35 $\begin{smallmatrix} -0.3 \\ -0.65 \end{smallmatrix}$	92 500	288 000	9 450	29 400	2 000	3 000	K135×143×35	0.300
	150	38 $\begin{smallmatrix} -0.3 \\ -0.65 \end{smallmatrix}$	145 000	325 000	14 800	33 500	2 000	3 000	K135×150×38	0.590
145	153	26 $\begin{smallmatrix} -0.3 \\ -0.65 \end{smallmatrix}$	72 000	214 000	7 350	21 800	1 900	2 800	K145×153×26	0.250
	153	28 $\begin{smallmatrix} -0.3 \\ -0.65 \end{smallmatrix}$	80 500	247 000	8 200	25 200	1 900	2 800	K145×153×28	0.252
	153	36 $\begin{smallmatrix} -0.3 \\ -0.65 \end{smallmatrix}$	100 000	325 000	10 200	33 000	1 900	2 800	K145×153×36	0.335
150	160	46 $\begin{smallmatrix} -0.3 \\ -0.65 \end{smallmatrix}$	149 000	470 000	15 200	48 000	1 800	2 700	K150×160×46	0.550
155	163	26 $\begin{smallmatrix} -0.3 \\ -0.65 \end{smallmatrix}$	73 500	224 000	7 500	22 800	1 700	2 600	K155×163×26	0.270
	163	36 $\begin{smallmatrix} -0.3 \\ -0.65 \end{smallmatrix}$	102 000	340 000	10 400	34 500	1 700	2 600	K155×163×36	0.355
160	170	46 $\begin{smallmatrix} -0.3 \\ -0.65 \end{smallmatrix}$	155 000	505 000	15 800	51 500	1 700	2 500	K160×170×46	0.570
165	173	26 $\begin{smallmatrix} -0.3 \\ -0.65 \end{smallmatrix}$	79 000	251 000	8 050	25 600	1 600	2 400	K165×173×26	0.290
	173	32 $\begin{smallmatrix} -0.3 \\ -0.65 \end{smallmatrix}$	97 000	330 000	9 900	33 500	1 600	2 400	K165×173×32	0.340
	173	36 $\begin{smallmatrix} -0.3 \\ -0.65 \end{smallmatrix}$	109 000	380 000	11 100	39 000	1 600	2 400	K165×173×36	0.375
170	180	46 $\begin{smallmatrix} -0.3 \\ -0.65 \end{smallmatrix}$	160 000	540 000	16 400	55 000	1 600	2 400	K170×180×46	0.620
175	183	32 $\begin{smallmatrix} -0.3 \\ -0.65 \end{smallmatrix}$	101 000	350 000	10 300	35 500	1 500	2 300	K175×183×32	0.360
185	195	37 $\begin{smallmatrix} -0.3 \\ -0.65 \end{smallmatrix}$	131 000	425 000	13 300	43 500	1 500	2 200	K185×195×37	0.560
195	205	37 $\begin{smallmatrix} -0.3 \\ -0.65 \end{smallmatrix}$	135 000	450 000	13 800	46 000	1 400	2 100	K195×205×37	0.620
210	220	42 $\begin{smallmatrix} -0.3 \\ -0.65 \end{smallmatrix}$	156 000	560 000	15 900	57 000	1 300	1 900	K210×220×42	0.740
220	230	42 $\begin{smallmatrix} -0.3 \\ -0.65 \end{smallmatrix}$	161 000	590 000	16 400	60 000	1 200	1 800	K220×230×42	0.790
240	250	42 $\begin{smallmatrix} -0.3 \\ -0.65 \end{smallmatrix}$	167 000	635 000	17 000	64 500	1 100	1 700	K240×250×42	0.850
265	280	50 $\begin{smallmatrix} -0.3 \\ -0.65 \end{smallmatrix}$	256 000	850 000	26 100	87 000	1 000	1 500	K265×280×50	1.810

Remarks: Even when an order is placed with reference to "Nominal bearing number" listed in this table, the ordered bearings are subject to being delivered with different cage type.

F_w 285mm

Boundary dimensions			Basic load ratings				Limiting speeds		Bearing numbers	Mass kg (approx.)
mm			dynamic	static	dynamic	static	r/min			
F_w	E_w	B_c	N		kgf		grease	oil		
			C_r	C_{or}	C_r	C_{or}				
285	300	50 $\begin{matrix} -0.3 \\ -0.65 \end{matrix}$	268 000	930 000	27 300	94 500	950	1 400	K285×300×50	1.970

Remarks: Even when an order is placed with reference to "Nominal bearing number" listed in this table, the ordered bearings are subject to being delivered with different cage type.

Inch System

Type PCJ

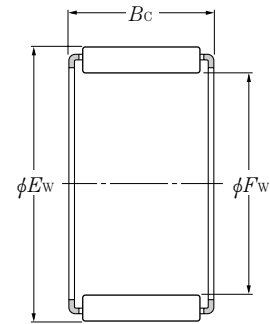

F_w 12.700~63.500mm

Boundary dimensions			Basic load ratings				Limiting speeds		Bearing numbers	Mass kg (approx.)
F_w	mm E_w	B_c ${}_{-0.35}^0$ (${}_{-0.014}^0$)	dynamic N C_r	static N C_{or}	dynamic kgf C_r	static kgf C_{or}	grease r/min	oil r/min		
12.700 ($\frac{1}{2}$)	15.875($\frac{5}{8}$)	12.70($\frac{1}{2}$)	6 650	8 600	680	875	16 000	24 000	PCJ081008	0.003
19.050 ($\frac{3}{4}$)	25.400(1)	25.40(1)	25 700	35 000	2 620	3 550	13 000	20 000	PCJ121616	0.023
22.225 ($\frac{7}{8}$)	28.575($1\frac{1}{8}$)	25.40(1)	29 600	44 000	3 000	4 450	11 000	17 000	PCJ141816	0.028
25.400 (1)	33.338($1\frac{5}{16}$)	19.05($\frac{3}{4}$)	29 200	38 500	2 980	3 950	10 000	15 000	PCJ162112	0.032
	33.338($1\frac{5}{16}$)	25.40(1)	38 000	54 000	3 850	5 500	10 000	15 000	PCJ162116	0.044
28.575 ($1\frac{1}{8}$)	38.100($1\frac{1}{2}$)	25.40(1)	44 000	60 000	4 500	6 100	9 500	14 000	PCJ182416	0.058
	38.100($1\frac{1}{2}$)	31.75($1\frac{1}{4}$)	53 500	77 000	5 450	7 850	9 500	14 000	PCJ182420	0.073
31.750 ($1\frac{1}{4}$)	41.275($1\frac{5}{8}$)	19.05($\frac{3}{4}$)	35 000	46 000	3 600	4 700	8 500	13 000	PCJ202612	0.045
	41.275($1\frac{5}{8}$)	25.40(1)	45 500	64 500	4 650	6 600	8 500	13 000	PCJ202616	0.062
	41.275($1\frac{5}{8}$)	38.10($1\frac{1}{2}$)	65 000	102 000	6 650	10 400	8 500	13 000	PCJ202624	0.096
34.925 ($1\frac{3}{8}$)	44.450($1\frac{3}{4}$)	31.75($1\frac{1}{4}$)	60 000	94 500	6 150	9 650	7 500	11 000	PCJ222820	0.090
	47.625($1\frac{7}{8}$)	25.40(1)	51 000	78 500	5 200	8 000	6 500	10 000	PCJ243016	0.075
	47.625($1\frac{7}{8}$)	31.75($1\frac{1}{4}$)	62 000	101 000	6 300	10 300	6 500	10 000	PCJ243020	0.095
38.100 ($1\frac{1}{2}$)	47.625($1\frac{7}{8}$)	38.10($1\frac{1}{2}$)	72 500	124 000	7 400	12 600	6 500	10 000	PCJ243024	0.114
	53.975($2\frac{1}{8}$)	25.40(1)	56 000	92 500	5 700	9 450	6 000	9 000	PCJ283416	0.086
	53.975($2\frac{1}{8}$)	31.75($1\frac{1}{4}$)	68 000	119 000	6 900	12 100	6 000	9 000	PCJ283420	0.110
44.450 ($1\frac{3}{4}$)	53.975($2\frac{1}{8}$)	38.10($1\frac{1}{2}$)	79 500	145 000	8 100	14 800	6 000	9 000	PCJ283424	0.132
	60.325($2\frac{3}{8}$)	25.40(1)	58 500	102 000	5 950	10 400	5 000	7 500	PCJ323816	0.094
	60.325($2\frac{3}{8}$)	31.75($1\frac{1}{4}$)	71 000	131 000	7 250	13 400	5 000	7 500	PCJ323820	0.120
50.800 (2)	60.325($2\frac{3}{8}$)	38.10($1\frac{1}{2}$)	83 000	160 000	8 450	16 300	5 000	7 500	PCJ323824	0.144
	52.388 ($2\frac{1}{16}$)	61.913($2\frac{7}{16}$)	25.40(1)	55 000	95 500	5 600	9 750	5 000	7 500	PCJ333916
53.975 ($2\frac{1}{8}$)	63.500($2\frac{1}{2}$)	25.40(1)	56 500	99 500	5 750	10 200	5 000	7 500	PCJ344016	0.091
	63.500($2\frac{1}{2}$)	38.10($1\frac{1}{2}$)	82 000	161 000	8 350	16 400	5 000	7 500	PCJ344024	0.144
57.150 ($2\frac{1}{4}$)	66.675($2\frac{5}{8}$)	25.40(1)	57 500	104 000	5 900	10 600	4 300	6 500	PCJ364216	0.094
60.325 ($2\frac{3}{8}$)	69.850($2\frac{3}{4}$)	38.10($1\frac{1}{2}$)	87 500	182 000	8 950	18 500	4 300	6 500	PCJ384424	0.161
63.500 ($2\frac{1}{2}$)	73.025($2\frac{7}{8}$)	25.40(1)	61 500	117 000	6 250	11 900	4 000	6 000	PCJ404616	0.105

F_w 63.500~101.600mm

F_w	Boundary dimensions		Basic load ratings				Limiting speeds		Bearing numbers	Mass kg (approx.)
	mm E_w	B_c ${}^0_{-0.35}({}^0_{-0.014})$	dynamic N C_r	static N C_{or}	dynamic kgf C_r	static kgf C_{or}	grease r/min	oil r/min		
63.500(2½)	73.025(2⅞)	38.10(1½)	89 000	189 000	9 100	19 300	4 000	4 000	PCJ404624	0.167
69.850(2¾)	79.375(3⅛)	25.40(1)	65 000	130 000	6 650	13 200	3 700	5 500	PCJ445016	0.116
76.200(3)	85.725(3⅜)	25.40(1)	68 500	143 000	7 000	14 600	3 300	5 000	PCJ485416	0.127
	85.725(3⅜)	38.10(1½)	99 500	231 000	10 100	23 500	3 300	5 000	PCJ485424	0.201
88.900(3½)	98.425(3⅞)	25.40(1)	75 000	169 000	7 650	17 200	2 900	4 400	PCJ566216	0.149
	101.600(4)	25.40(1)	82 000	154 000	8 350	15 700	2 900	4 400	PCJ566416	0.187
	101.600(4)	38.10(1½)	121 000	253 000	12 300	25 800	2 900	4 400	PCJ566424	0.305
101.600(4)	114.300(4½)	25.40(1)	87 500	176 000	8 950	18 000	2 500	3 800	PCJ647216	0.212
	114.300(4½)	38.10(1½)	129 000	290 000	13 200	29 500	2 500	3 800	PCJ647224	0.345

Needle Roller and Cage Assemblies for connecting rod bearings

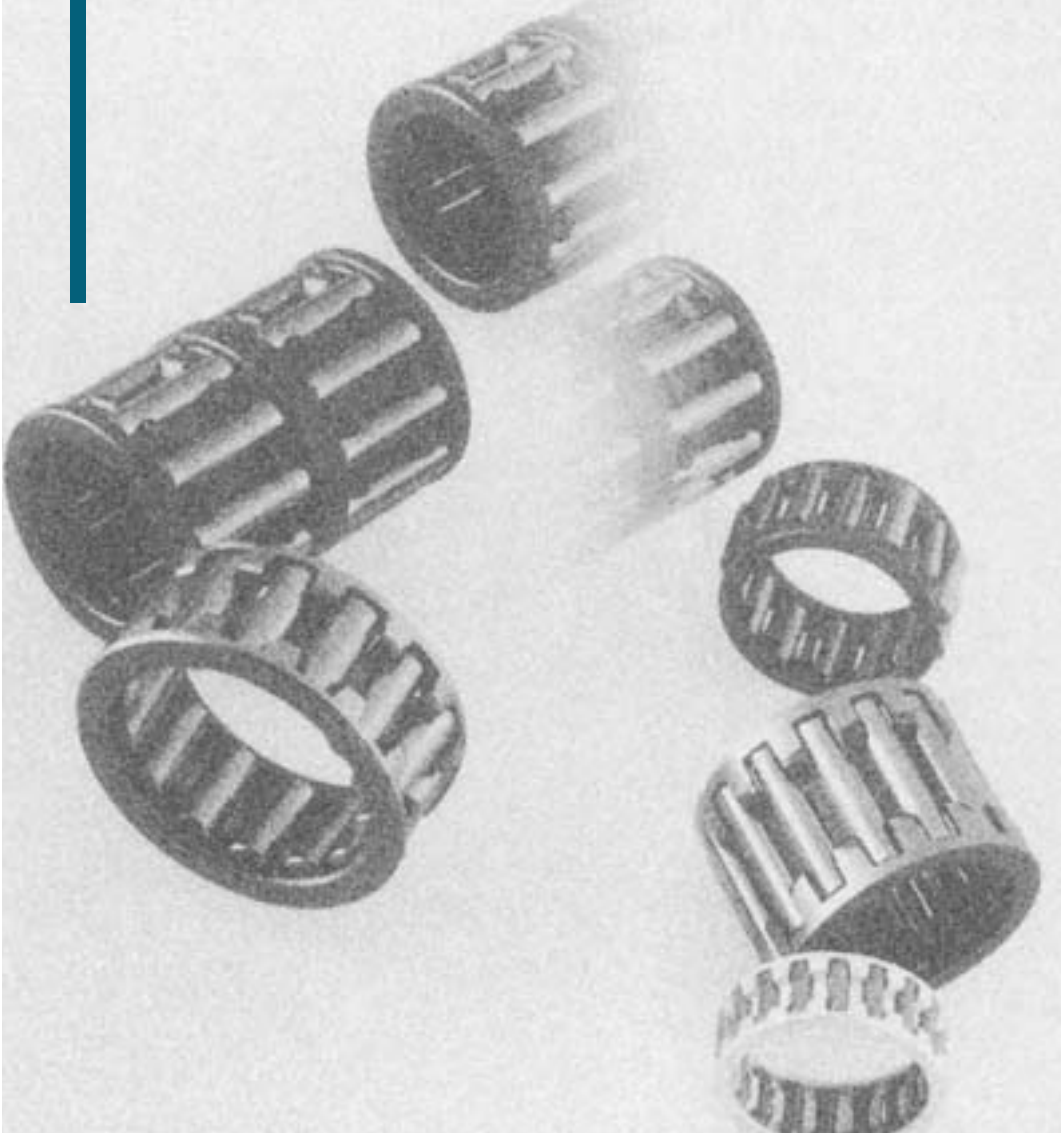

Needle Roller and Cage Assemblies for connecting rod bearings

These needle roller and cage assemblies are specially designed so as to be adaptable to the operating environmental conditions for the connecting rods of small and medium reciprocal engines and compressors.

The connecting rods are used under a severe operating condition wherein acting load magnitude and

direction fluctuate rapidly as well as under an high temperature and strict lubrication environment. Therefore, special measures are mainly undertaken for the cage structure, material and machining method so that the needle roller and cage assemblies are resistible to the said operating condition and environment.

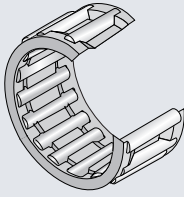
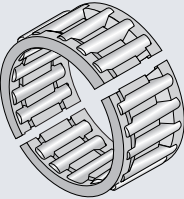
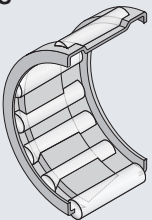
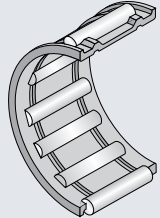
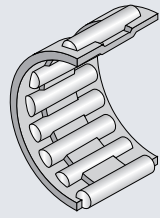
Type of needle roller and cage assembly	Location	Cage type	Applied shaft diameter (mm)	Composition of nominal bearing number
PK 	Large end side	Machined ring type	$\phi 10 \sim \phi 38$	PK 20 × 26 × 13.8 × 1 Type code Inscribed circle diameter Roller set outer diameter Width Tail code
GPK 				GPK 20 × 26 × 13.8 X Type code Inscribed circle diameter Roller set outer diameter Width Tail code
KMJ · S 	Small end side	Welded type	$\phi 10 \sim \phi 38$	KMJ 10 × 14 × 8.8 S Type code Inscribed circle diameter Roller set outer diameter Width Tail code
KBK 				KBK 14 × 18 × 17 Type code Inscribed circle diameter Roller set outer diameter Width
KV · S 				KV 8 × 11 × 8 S V4 Type code Inscribed circle diameter Roller set outer diameter Width Tail code Tail code

Nominal bearing number	Code items and respective dimensions	Remarks
PK20×26×13.8X1	Inscribed circle diameter : ϕ 20 Roller set outer diameter : ϕ 26 Width : 13.8 X1 : numbering up	Cage intended to guide outer ring, eventually surface- treated by non-ferrous plating, etc.
GPK20× 26 × 13.8X	Inscribed circle diameter : ϕ 20 Roller set outer diameter : ϕ 26 Width : 13.8	Cage intended to guide outer ring, eventually surface- treated by non-ferrous plating, etc. Can be applied to a crank of integral structure.
KMJ10×14×8.8S	Inscribed circle diameter : ϕ 10 Roller set outer diameter : ϕ 14 Width : 8.8 S : welded type	Cage intended to guide outer ring, eventually surface- treated by non-ferrous plating, etc.
KBK14×18×17	Inscribed circle diameter : ϕ 14 Roller set outer diameter : ϕ 18 Width : 17	Type KBK is intended to guide inner ring, which of the guide surface is designed as long as possible to thereby reduce the surface pressure. In addition, the roller length is so designed as to be maximum against the width of connecting rod, for high load capacity. On the other hand, Type V••S intended for outer ring guide needs a guide along the bore surface of connecting rod.
KV8×11×8SV4	Inscribed circle diameter : ϕ 8 Roller set outer diameter : ϕ 11 Width : 8 S : welded type V4 : numbering up	

Radial clearance

Table 1 shows the recommended clearance values though the radial clearance differs depending on bearing clearance, load, revolutions and ambient temperature.

The proper radial clearance can be got by proper selection and combination of roller diameter, connecting rod hole diameter and pin diameter. **Table 2** shows the examples of selection and combination of those.

Table 1 Recommended clearance values

Unit : μm

Pin diameter mm		Large end side	Small end side
Over	incl.		
6	10	9~23	5~17
10	18	10~24	5~17
18	30	10~24	5~17
30	40	18~33	—

Table 2 Radial clearance values obtainable by selection and combination

Case of needle roller and cage assembly Type PK for crank pin

Crank pin hole diameter 22mm H6 (0 to +13 μm)

Crank pin diameter 14mm h5 (0 to -8 μm)

Unit : μm

Pin diameter sorting class	Hole diameter sorting class	0~+4	+4~+8	+8~+13
	Sorting class of needle roller used	-4~-6	-2~-4	0~-2
0~-3		10~17	10~17	10~18
-3~-6		13~20	13~20	13~21
-6~-8		16~22	16~22	16~23

Connecting rod and pin specifications

Connecting rod (bore surface), crank pin and piston pin (outer surface) can be used as direct raceway surface. However, these surfaces must be resistible to great load while maintaining high accuracy. For that, connecting rods and pins acting as the direct raceway surface must comply with the specifications specified hereunder.

Any connecting rods shall be made of cement steel, e.g. chrome molybdenum steel (SCM415, etc.), nickel chrome molybdenum steel (SNCM420, etc.) and any crank pins and piston pins shall also be made of cement steel, e.g. chrome steel (SCr420, etc.), all of which shall be surface-hardened by carburizing.

The surface hardness of each shall range from HRC58 to 64 and adequate depth of effective carburizing-hardened layer shall be secured up to Hv550. The depth of effective carburizing-hardened layer differs depending on actual load and pin diameter.

Feel free to contact NTN for the more detailed information.

The respective profile accuracy of connecting rod hole, crank and piston pin outer surfaces shall be as specified in **Table 3**.

Furthermore, the parallelism of crank pin and piston pin shall be 0.02mm or less against 100mm. (**Fig. 1**)

The surface roughness shall be 0.2a for connecting rod and 0.1a for pin outer surface as a guideline.

Table 3 Recommended accuracy of connecting rod and pin

Unit : μm

Parts	Characteristics	Pin diameter classification mm				
		~14	14~18	18~25	25~30	30~40
Connecting rod	Roundness (max)	3	4	4	5	5
	Cylindricity (max)	2	3	3	4	4
Pin	Roundness (max)	2	2	3	3	4
	Cylindricity (max)	1	1	2	2	3

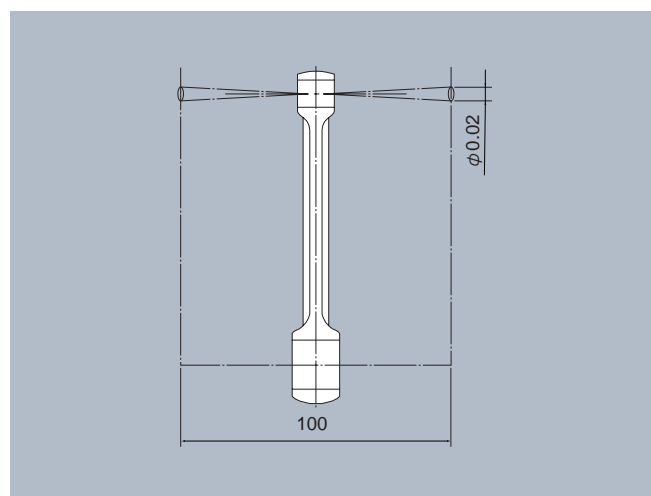

Fig. 1

Regulation to connecting rod

Two methods are available as follows to regulate axial motion of a connecting rod; one method is to make smaller a clearance between the rod and crank web at large end side (Method of regulating at large end side) and another method is to narrow a clearance between the rod and piston boss at the small end side (Method of regulating at small end side).

In general, the method of regulation at large end side is mostly adopted to get accurate motion of a connecting rod.

On the other hand, the method of regulation at small end side is adopted when regulation at large end side disables to secure good lubrication to the bearing and the guide surface at large end side due to short connecting rod and comparatively high revolutions.

Regulation at large end side

This method regulates axial motion of a connecting rod by forming a sliding surface between the large end of the connecting rod and the side face of crank web. For the use of this method, however, the connecting rod must be provided, on its bore surface, with oil hole, slot and oil groove to feed lubrication oil in and onto the bearing and guide surface at large end side.

The crank web end face shall be surface-hardened as necessary or otherwise a side washer of copper alloy or hardened steel shall be fitted on the guide surface.

On the other hand, the needle roller and cage assembly at small end side shall be guided in axial direction by the side face of piston boss. A great play shall be secured between the piston boss and the connecting rod.

Regulation at small end side

This method regulates axial motion at the small end face of a connecting rod and the side face of a piston rod. Generally a connecting rod is not provided with oil groove and slot to lubricate the guide surface at small end side, but on occasion it is surface-hardened and uses a side washer.

Usually a connecting rod shall be provided with a through-hole (at its small end side) to lubricate the bearing unit.

On the other hand, at the large end side a free clearance exists between the connecting rod and the crank web and, therefore, generally special measures such as oil groove to lubricate, etc.

may be omitted.

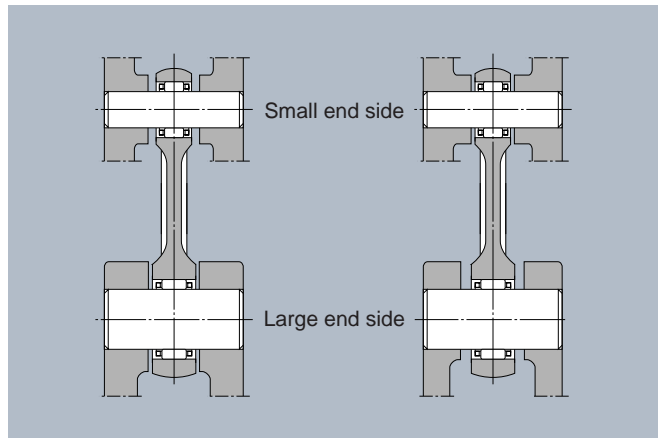
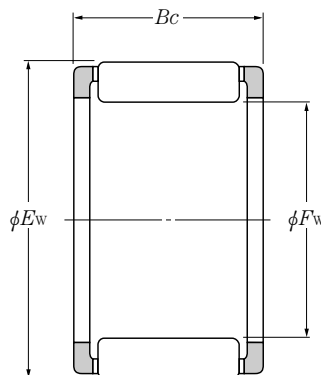

Fig. 2. Regulation at large end side Fig. 3 Regulation at small end side

For crank-pin

Type PK

 F_w 10~30mm

Boundary dimensions			Basic load ratings				Bearing numbers	Mass kg (approx.)
F_w	mm		dynamic	static	dynamic	static		
	E_w	B_c	N		kgf			
		$0_{-0.2}$	C_r	C_{or}	C_r	C_{or}		
10	14	9.8	5 050	4 900	515	500	PK10×14× 9.8X1	0.0037
12	16	10	5 450	5 600	555	570	PK12×16× 10.2	0.0044
	17	9.8	6 800	6 550	695	670	PK12×17× 9.8X2	0.0051
14	19	9.7	7 300	7 400	745	755	PK14×19× 9.7X1	0.0065
15	20	9.8	7 250	7 450	740	760	PK15×20× 9.8X	0.0067
	21	11.8	10 000	10 200	1 020	1 040	PK15×21× 11.8X1	0.0096
16	22	11.8	10 000	10 300	1 020	1 050	PK16×22× 11.8X2	0.0097
	22	13.2	10 900	11 500	1 110	1 170	PK16×22× 13.2X	0.0110
18	24	11.8	11 300	12 400	1 150	1 260	PK18×24× 11.8X3	0.0110
	24	13.3	13 300	15 300	1 360	1 560	PK18×24× 13.3X1	0.0120
19	24	13.9	11 900	15 200	1 220	1 550	PK19×24× 13.9X	0.0110
	25	15.8	14 300	17 000	1 460	1 730	PK19×25× 15.8X1	0.0150
20	26	13.8	14 000	16 700	1 420	1 700	PK20×26× 13.8X6	0.0140
22	28	15.8	15 900	20 200	1 620	2 060	PK22×28× 15.8X1	0.0170
	29	17.8	18 800	22 800	1 920	2 320	PK22×29× 17.8X7	0.0240
	30	14.7	16 900	18 200	1 720	1 860	PK22×30× 14.7X2	0.0240
	30	17.8	21 900	25 400	2 230	2 590	PK22×30× 17.8X2	0.0270
24	31	16.8	20 800	26 600	2 120	2 710	PK24×31× 16.8X7	0.0240
	32	19.8	22 900	27 500	2 340	2 810	PK24×32× 19.8X6	0.0330
26	31	13.8	14 200	20 900	1 450	2 130	PK26×31× 13.8X2	0.0150
	34	16.8	21 600	26 100	2 200	2 660	PK26×34× 16.8X7	0.0320
27	36	20.8	30 500	38 500	3 150	3 950	PK27×36× 20.8X1	0.0440
28	36	15.8	23 700	30 000	2 410	3 050	PK28×36× 15.8X6	0.0310
	37	20.8	32 500	41 500	3 300	4 250	PK28×37× 20.8X	0.0480
29	39	21.4	32 500	39 500	3 300	4 000	PK29×39× 21.4X2	0.0550
30	37	15.9	21 900	30 500	2 230	3 100	PK30×37× 15.9X	0.0280
	38	15.8	24 600	32 000	2 510	3 300	PK30×38× 15.8X	0.0320

F_w 30~38mm

Boundary dimensions			Basic load ratings				Bearing numbers	Mass kg (approx.)
F_w	mm		dynamic	static	dynamic	static		
	E_w	B_c	N		kgf			
		-0.2	C_r	C_{or}	C_r	C_{or}		
30	38	17.8	27 700	37 500	2 820	3 800	PK30×38×17.8X1	0.037
31	41	21.4	34 000	43 000	3 500	4 350	PK31×41×21.4X	0.057
32	43	22.4	40 000	49 500	4 100	5 050	PK32×43×22.4X	0.069
34	42	19.8	31 500	45 500	3 200	4 650	PK34×42×19.8X	0.046
38	47	19.8	35 500	51 000	3 600	5 200	PK38×47×19.8X1	0.056

For piston-pin

Type KBK

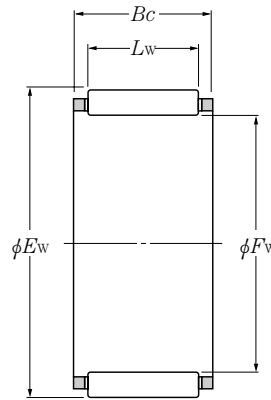
 F_w 7~22mm

Boundary dimensions				Basic load ratings				Bearing numbers	Mass kg (approx.)
F_w	E_w	mm B_c -0.2	L_w	dynamic N C_r	static C_{or}	dynamic kgf C_r	static C_{or}		
7	10	9.8	6.8	3 050	2 780	310	284	KBK 7×10× 9.8X	0.0022
8	11	11.8	8.8	4 100	4 200	415	430	KBK 8×11× 11.8X1	0.0028
9	12	11.5	8.8	4 400	4 750	450	485	KBK 9×12× 11.7	0.0030
10	14	9.8	6.8	4 500	4 200	460	430	KBK10×14× 9.8X	0.0042
	14	12.5	9.8	6 100	6 200	620	635	KBK10×14× 12.5X1	0.0053
	14	14.8	9.8	6 100	6 200	620	635	KBK10×14× 14.8X	0.0064
11	14	13.5	10.8	5 850	7 250	595	740	KBK11×14× 13.5X1	0.0044
12	15	16.4	13.8	7 500	10 200	765	1 040	KBK12×15× 16.6	0.0055
	16	14.8	11.8	7 600	8 600	775	875	KBK12×16× 14.8X	0.0072
	16	15.4	9.8	7 000	7 800	715	795	KBK12×16× 15.6	0.0079
	16	15.8	12.8	8 100	9 350	825	955	KBK12×16× 16	0.0073
	17	14.8	9.8	8 400	8 550	855	875	KBK12×17× 14.8X	0.0094
14	18	16.8	13.8	9 750	12 400	995	1 260	KBK14×18× 17	0.0089
	18	19.8	13.8	9 150	11 300	930	1 160	KBK14×18× 20	0.0130
	19	17.1	12.8	11 100	12 700	1 130	1 300	KBK14×19× 17.1X	0.0120
15	19	17.3	13.8	10 900	14 600	1 110	1 490	KBK15×19× 17.3X	0.0100
16	20	16.8	13.8	10 800	14 700	1 100	1 500	KBK16×20× 17	0.0100
	20	19.6	13.8	10 200	13 600	1 040	1 390	KBK16×20× 19.8	0.0130
	20	23.8	19.8	13 600	19 700	1 390	2 010	KBK16×20× 23.8X	0.0150
	21	19.6	15.8	13 900	17 600	1 420	1 790	KBK16×21× 19.6X	0.0160
17	21	23	15.8	13 200	19 400	1 340	1 980	KBK17×21× 23.2	0.0160
	21	25	17.8	13 100	19 200	1 340	1 960	KBK17×21× 25X	0.0170
	22	22	18.8	16 900	22 900	1 720	2 340	KBK17×22× 22X1	0.0170
18	22	21.8	15.8	12 500	18 300	1 270	1 870	KBK18×22× 21.8X3	0.0150
	22	23.8	17.8	13 000	19 300	1 330	1 970	KBK18×22× 23.8X1	0.0160
20	25	27.9	21.8	20 800	31 500	2 120	3 200	KBK20×25× 27.9X	0.0270
22	28	29.9	23.8	26 000	38 000	2 650	3 900	KBK22×28× 29.9X1	0.0390

Drawn Cup Needle Roller Bearings

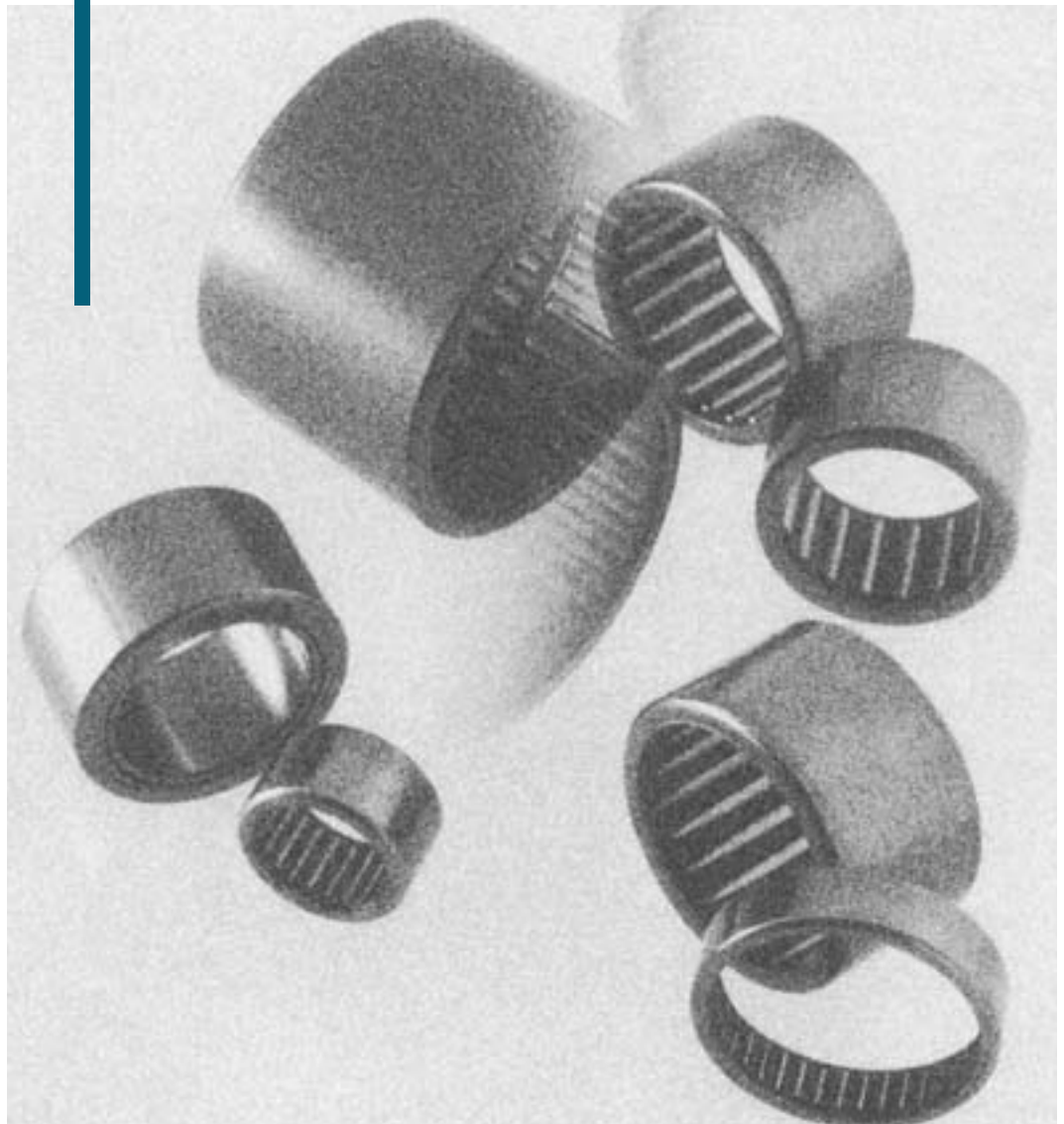

Drawn Cup Needle Roller Bearings

This bearing type is composed of an outer ring drawn from a thin steel plate by precision drawing, needle rollers and a cage assembled in the outer ring after the raceway surface thereof was hardened. Of the bearings with outer ring, this bearing type is a bearing with the smallest section height which enables space-saving and cost-saving.

Usually design is so made as to use a shaft as the direct raceway surface without using inner ring. The outer ring of this bearing type is of such a construction that the needle rollers and the cage are not separated from one another, so that the bearing is only press-fitted in a rigid housing with proper fit torque. Thus, this bearing type needs no snap ring, etc. to fix itself in axial direction and, in addition, is easy to handle.

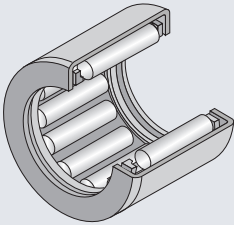
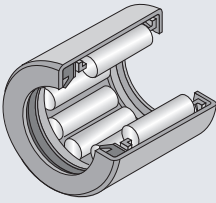
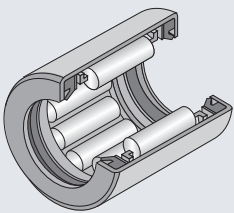
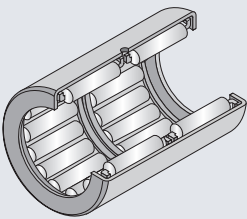
Type of bearing	Applied shaft diameter (mm)	Composition of nominal bearing number	Nominal bearing number	Code items and dimensions	Remarks
HK (HK·T2) 	Open end $\phi 3 \sim \phi 50$	HK 06 09 T2 Tail code Width Inscribed circle diameter Type code [Tail code] T2 : Resin cage C : Welding cage	HK0609T2	Inscribed circle diameter : $\phi 6$ Width : 9 T2 : Resin cage	The bearings with tail code T2 using polyamide resin cage shall be used at allowable temperature 120°C and, under continuous running, at 100°C and less.
HK·L 	Open end single side seal $\phi 12 \sim \phi 50$	HK 20 18 L Tail code Width Inscribed circle diameter Type code	HK2018L	Inscribed circle diameter : $\phi 20$ Width : 18 L : single side seal	This seal type (Tail code : L or LL) synthetic rubber seal built in at its single side or double sides is internally filled with lithium soap base grease. The operating temperature shall range from -25 to 100°C maximum to prevent deterioration of the seal and filled-up grease. The roller length and rated load of this bearing type are shorter and smaller than those of the open type of same dimension.
HK·LL 	Open end double-side seal $\phi 12 \sim \phi 50$	HK 20 20 LL Tail code Width Inscribed circle diameter Type code	HK2020LL	Inscribed circle diameter : $\phi 20$ Width : 20 LL: Double-side seal	
HK·ZWD 	Open end double-row type $\phi 15 \sim \phi 30$	HK 20 30 ZW D Tail code Tail code Width Inscribed circle diameter Type code	HK2030ZWD	Inscribed circle diameter : $\phi 20$ Width : 30 ZW : Double-row cage D : Outer ring with oil hole	

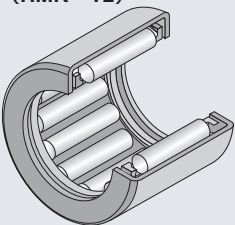
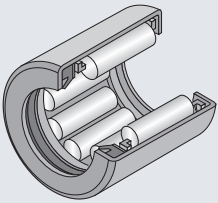
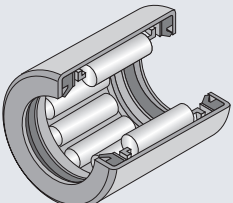
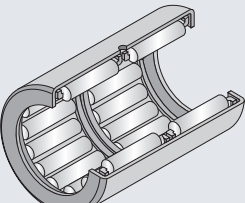
Type of bearing	Applied shaft diameter (mm)	Composition of nominal bearing number	Nominal bearing number	Code items and dimensions	Remarks	
 <p>HMK (HMK·T2)</p>	Open end	$\phi 8 \sim \phi 50$	<p>HMK 20 15</p> <p>Type code Inscribed circle diameter Width</p>	HMK2015	Inscribed circle diameter : $\phi 20$ Width : 15	The bearings with tail code T2 using polyamide resin cage shall be used at allowable temperature 120°C and, under continuous running, at 100°C and less.
 <p>HMK·L</p>	Open end single side seal	$\phi 8 \sim \phi 50$	<p>HMK 20 18 L</p> <p>Type code Inscribed circle diameter Width Tail code</p>	HMK2018L	Inscribed circle diameter : $\phi 20$ Width : 18 L : single side seal	This seal type (Tail code : L or LL) synthetic rubber seal built in at its single side or double sides is internally filled with lithium soap base grease. The operating temperature shall range from -25 to 100°C maximum to prevent deterioration of the seal and filled-up grease.
 <p>HMK·LL</p>	Open end double-side seal	$\phi 8 \sim \phi 50$	<p>HMK 20 21 LL</p> <p>Type code Inscribed circle diameter Width Tail code</p>	HMK2021LL	Inscribed circle diameter : $\phi 20$ Width : 21 LL: Double-side seal	The roller length and rated load of this bearing type are shorter and smaller than those of the open type of same dimension.
 <p>HMK·ZWD</p>	Open end double-row type	$\phi 38 \sim \phi 50$	<p>HMK 38 45 ZW D</p> <p>Type code Inscribed circle diameter Width Tail code Tail code</p>	HK3845ZWD	Inscribed circle diameter : $\phi 38$ Width : 45 ZW : Double-row cage D : Outer ring with oil hole	This type is provided with oil hole on its outer ring.

Heavy load series

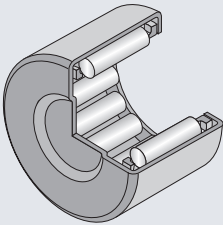
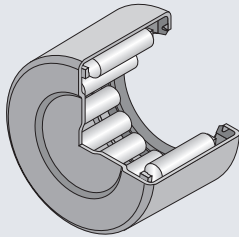
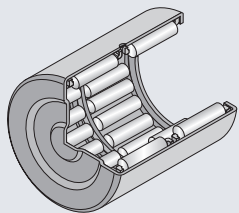
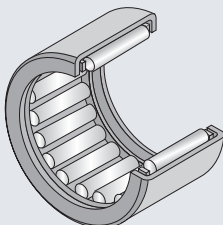
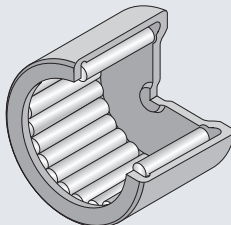
Type of bearing		Applied shaft diameter (mm)	Composition of nominal bearing number	Nominal bearing number	Code items and dimensions	Remarks		
BK (BK·T2) 	Standard series	Closed end	$\phi 3 \sim \phi 50$	BK 20 20 C Type code Inscribed circle diameter Width Tail code	BK2020C	Inscribed circle diameter : $\phi 20$ Width : 20 C : Welding cage	The bearings with tail code T2 using polyamide resin cage shall be used at allowable temperature 120°C and, under continuous running, at 100°C and less.	
BK·L 		Closed end single side seal	$\phi 12 \sim \phi 50$	BK 20 18 L Type code Inscribed circle diameter Width Tail code	BK2018L	Inscribed circle diameter : $\phi 20$ Width : 18 L : single side seal	This seal type (Tail code: L) is internally filled up with lithium soap base grease. The operating temperature shall range from -25 to 100°C maximum to prevent deterioration of the seal and filled-up grease.	
BK·ZWD 		Closed end double-row type	$\phi 15 \sim \phi 30$	BK 20 30 ZW D Type code Inscribed circle diameter Width Tail code Tail code	BK2030ZWD	Inscribed circle diameter : $\phi 20$ Width : 30 ZW : Double-row cage D : Outer ring with oil hole	Inscribed circle diameter	
DCL 		Inch series	Open end	$\phi 6.35 \sim \phi 50.8$	DCL 16 20 Type code Inscribed circle diameter code Width code	DCL1620	Inscribed circle diameter : $\phi 25.4$ Width : 31.75	
HCK 			Bearing series for universal joints	Closed end	$\phi 10 \sim \phi 20$	HCK 16 22 Type code Inscribed circle diameter Outer diameter	HCK1622	Inscribed circle diameter : $\phi 16$ Width : $\phi 22$

Bearing Fits

It is common that drawn cup needle bearing is press-fitted in a housing by shrinkage fit so post press-fit inscribed circle diameter (F_w) comes to ISO Tolerance Rang Class F8. The post press-fit inscribed circle diameter (F_w) depends on the housing material and rigidity. It is therefore desirable to decide the interference based on the data measured in pre-testing.

Where the housing rigidity is adequately high, the post press-fit inscribed circle diameter (F_w) is secured in nearly F8 range and nearly ordinary radial clearance can be got by adopting the data of bearing fit in housing and on shaft as shown in **Table-1**.

Table 1 Bearing fit in housing and on shaft

Bearing type	Housing		Shaft	
	Iron series	Light alloy	Without inner ring	With inner ring
HK,BK	N6 (N7)	R6 (R7)	h5 (h6)	k5 (j6)
HMK,DCL	J6 (J7)	M6 (M7)	h5 (h6)	k5 (j6)
HCK	F7	—	k6	—

Accuracy of housing bore

Because of its thin-walled outer ring, the performance of drawn cup needle roller bearing is greatly affected by the dimensional accuracy, profile accuracy and bore surface roughness of a housing in which the bearing is press-fitted. To avoid such an inverse affect, the housing bore(hole) must have the accuracy as specified in **Table 2**. For the shaft accuracy refer to **Subsection 7.3 "Accuracy of Shaft and Housing"** (on page A-39).

Table 2 Accuracy of housing bore

Property	Tolerance
Roundness (Max)	IT4 or less
Cylindricity (Max)	IT4 or less
Surface roughness (Max)	1.6a

Oil hole dimension in outer ring

The outer rings of double-row (Tail code : ZW) needle roller and cage assembly Type HK and Type BK are provided with an oil hole to facilitate oil lubrication to the bearing. **Table 3** shows the nominal oil hole diameter.

Table 3 Diameter of oil hole in outer ring (Metric system)

Outer ring diameter		Nominal oil hole diameter
Over	incl.	
5	10	1.5
10	20	2.0
20	40	2.5
40	80	3.0
80	200	3.5

Bearing installation

Any drawn cup needle roller bearings must be press-fitted in the housing in specific position by holding a specific jig in perfect contact with the mark-stamped side face of the bearing, without fail.

Further, hammering directly the bearing ring in installing (press-fitting) is not allowed absolutely. In installing, it is recommended to use a mandrel with O-ring as illustrated in **Fig.1** as a press-fitting jig. The use of this mandrel would enable to insert easily any drawn cup needle bearing in a housing without risk of twisting and fall-down.

Drawn cup needle roller bearing needs no a snap ring and a shoulder for positioning itself in a housing, **but the bearing must be press-fitted so carefully as not to allow its side face to strike the shoulder for preventing it from deforming, where press-fitted in a housing with shoulder.**

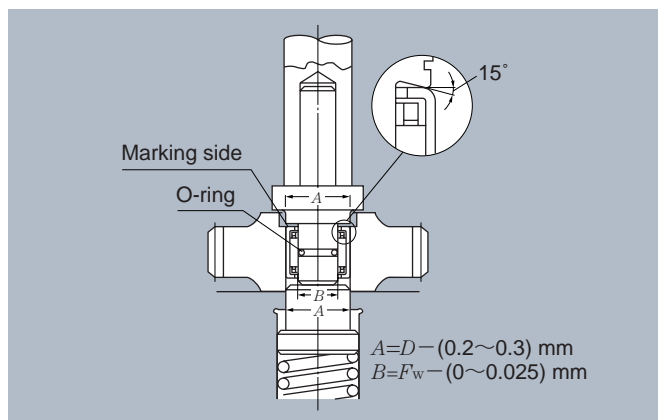

Fig. 1

The Type HCK for application to universal joints is fixed to the joint yoke by caulking, using a special-purposed assembler. Feel free to contact **NTN** for any inquiry about the special-purposed assembler (IPH Machine).

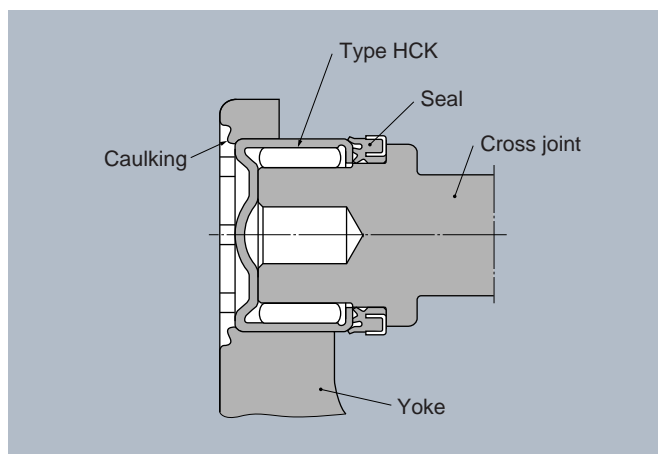

Fig. 2

Bearing Tolerances and Measuring Methods

The outer ring of drawn cup needle roller bearing is so thin-walled that deformation thereof to a certain extent is unavoidable in the manufacturing processes, particularly in the heat-treating process. However, the outer ring is so designed that it is reformed normally from such deformation when being press-fitted in a housing with specific dimensional accuracy and, as a result, it can have the accuracy required to fulfill its specific function.

Hence, **it is meaningless to measure the dimensional accuracy of bearing itself before being press-fitted. So, the following measuring method is used; a bearing to be measured is press-fitted in a linkage of specific dimension (20mm or more in wall**

thickness) and thereafter the inscribed circle diameter (F_w) is measured using a plug gauge or a taper gauge to evaluate the bearing accuracy.

Tables 4 to 7 show the dimensional tolerances for the bore diameter of each ring gauge and the inscribed circle diameter (F_w) each of standard metric series drawn cup needle roller bearings Type HK and BK, heavy load series Type HMK (metric series), inch series Type DCL, and inch series HCK for application to universal joints. When measuring the inscribed circle diameter of roller, the low tolerance for the inscribed circle diameter shall be applied to the dimension at "GO" side and the value of the high tolerance for the inscribed circle diameter plus (+) $2\mu\text{m}$ shall be applied to the dimension at "NOT GO" side in compliance with the relevant ISO standard.

Table 4 Dimensional tolerance for inscribed circle diameter (Type HK and BK)

Unit : mm

Nominal inscribed circle dia. F_w	Nominal outer ring outer dia. D	Ring gauge bore dia.	Tolerance for inscribed circle diameter	
			High	Low
3	6.5	6.484	3.016	3.006
4	8	7.984	4.022	4.010
5	9	8.984	5.022	5.010
6	10	9.984	6.022	6.010
7	11	10.980	7.028	7.013
8	12	11.980	8.028	8.013
9	13	12.980	9.028	9.013
10	14	13.980	10.028	10.013
12	16	15.980	12.034	12.016
12	18	17.980	12.034	12.016
13	19	18.976	13.034	13.016
14	20	19.976	14.034	14.016
15	21	20.976	15.034	15.016
16	22	21.976	16.034	16.016
17	23	22.976	17.034	17.016
18	24	23.976	18.034	18.016
20	26	25.976	20.041	20.020
22	28	27.976	22.041	22.020
25	32	31.972	25.041	25.020
28	35	34.972	28.041	28.020
30	37	36.972	30.041	30.020
35	42	41.972	35.050	35.025
40	47	46.972	40.050	40.025
45	52	51.967	45.050	45.025
50	58	57.967	50.050	50.025
55	63	62.967	55.060	55.030
60	68	67.967	60.060	60.030

Table 5 Dimensional tolerance for inscribed circle diameter (Type HMK)

Unit : mm

Nominal inscribed circle dia. F_w	Nominal outer ring outer dia. D	Ring gauge bore dia.	Tolerance for inscribed circle diameter	
			High	Low
8	15	14.995	8.028	8.013
9	16	15.995	9.028	9.013
10	17	16.995	10.028	10.013
12	19	18.995	12.034	12.016
14	22	21.995	14.034	14.016
15	22	21.995	15.034	15.016
16	24	23.995	16.034	16.016
17	24	23.995	17.034	17.016
18	25	24.995	18.034	18.016
19	27	26.995	19.041	19.020
20	27	26.995	20.041	20.020
21	29	28.995	21.041	21.020
22	29	28.995	22.041	22.020
24	31	30.994	24.041	24.020
25	33	32.994	25.041	25.020
26	34	33.994	26.041	26.020
28	37	36.994	28.041	28.020
29	38	37.994	29.041	29.020
30	40	39.994	30.041	30.020
32	42	41.994	32.050	32.025
35	45	44.994	35.050	35.025
37	47	46.994	37.050	37.025
38	48	47.994	38.050	38.025
40	50	49.994	40.050	40.025
45	55	54.994	45.050	45.025
50	62	61.994	50.050	50.025

Table 6 Dimensional tolerance for inscribed circle diameter (Type DCL)
Unit : mm

Nominal inscribed circle dia. F_w	Nominal outer ring outer dia. D	Ring gauge bore dia.	Tolerance for inscribed circle diameter	
			High	Low
6.350	11.112	11.125	6.411	6.388
7.938	12.700	12.713	7.998	7.976
9.525	14.288	14.300	9.586	9.563
11.112	15.875	15.888	11.173	11.151
12.700	17.462	17.475	12.761	12.738
14.288	19.050	19.063	14.348	14.326
15.875	20.638	20.650	15.936	15.913
17.462	22.225	22.238	17.523	17.501
19.050	25.400	25.387	19.086	19.063
20.638	26.988	26.975	20.673	20.650
22.225	28.575	28.562	22.261	22.238
23.812	30.162	30.150	23.848	23.825
25.400	31.750	31.737	25.436	25.413
26.988	33.338	33.325	27.023	27.000
28.575	34.925	34.912	28.611	28.588
30.162	38.100	38.087	30.198	30.175
31.750	38.100	38.087	31.786	31.763
34.925	41.275	41.262	34.963	34.938
38.100	47.625	47.612	38.141	38.113
41.275	50.800	50.787	41.316	41.288
44.450	53.975	53.962	44.493	44.463
47.625	57.150	57.137	47.668	47.638
50.800	60.325	60.312	50.846	50.815

Table 7 Dimensional tolerance for inscribed circle diameter (Type HCK)
Unit : mm

Nominal inscribed circle dia. F_w	Nominal outer ring outer dia. D	Ring gauge bore dia.	Tolerance for inscribed circle diameter	
			High	Low
10	15	15.016	10.026	10.011
11.656	17.1	17.116	11.687	11.669
13	19	19.020	13.031	13.013
14	20	20.020	14.031	14.013
16	22	22.020	16.031	16.013
18	24	24.020	18.031	18.013
18	24.6	24.620	18.031	18.013
20	27.9	27.920	20.038	20.017

Type HK, Type HK · · ZWD
 Type HMK
 Type BK, Type BK · · ZWD

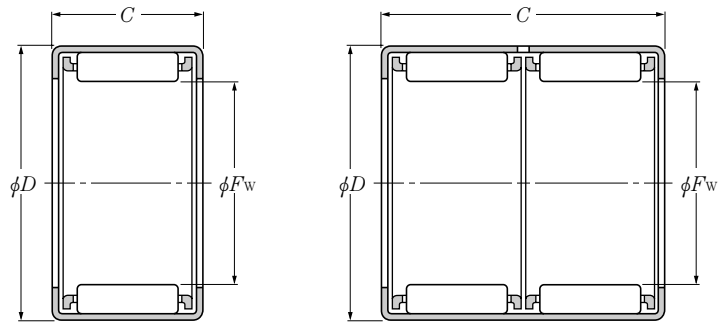

Type HK, Type HMK

Type HK · · ZWD

Opened End Type

F_w 3~10mm

Boundary dimensions	Basic load ratings				Limiting speeds		Bearing numbers		Mass kg (approx.)	Appropriate ¹⁾ inner ring (as a reference)			
	mm				r/min		open end design	closed end design					
	F_w	D	C 0 -0.2	C_1 max	dynamic N	static kgf					grease	oil	
				C_r	C_{or}	C_r	C_{or}						
3	6.5	6	—	925	565	94	58	33 000	50 000	HK0306T2	—	0.0006	—
	6.5	6	0.8	925	565	94	58	33 000	50 000	—	BK0306T2	0.0007	—
4	8	8	—	1 770	1 270	180	129	30 000	45 000	HK0408T2	—	0.0016	—
	8	8	1.6	1 770	1 270	180	129	30 000	45 000	—	BK0408T2	0.0018	—
5	9	9	—	2 640	2 190	269	224	27 000	40 000	HK0509T2	—	0.0019	—
	9	9	1.6	2 640	2 190	269	224	27 000	40 000	—	BK0509T2	0.0021	—
6	10	9	—	2 660	2 280	272	233	25 000	37 000	HK0609T2	—	0.0022	—
	10	9	1.6	2 660	2 280	272	233	25 000	37 000	—	BK0609T2	0.0024	—
7	11	9	—	3 400	3 250	345	330	23 000	34 000	HK0709	—	0.0025	—
	11	9	1.6	3 400	3 250	345	330	23 000	34 000	—	BK0709	0.0027	—
8	12	10	—	3 850	3 950	395	400	20 000	30 000	HK0810C	—	0.0032	IR 5× 8×12
	12	10	1.6	3 850	3 950	395	400	20 000	30 000	—	BK0810C	0.0034	IR 5× 8×12
	15	10	—	3 800	2 870	390	293	20 000	30 000	HMK0810	—	0.0067	IR 5× 8×12
	15	15	—	6 600	5 800	675	590	20 000	30 000	HMK0815	—	0.0100	IR 5× 8×16
	15	20	—	9 050	8 750	925	890	20 000	30 000	HMK0820T2	—	0.0130	—
9	13	10	—	4 750	5 300	485	540	18 000	27 000	HK0910	—	0.0035	IR 6× 9×12
	13	10	1.6	4 750	5 300	485	540	18 000	27 000	—	BK0910	0.0039	IR 6× 9×12
	13	12	—	5 650	6 650	575	680	18 000	27 000	HK0912	—	0.0042	IR 6× 9×12
	13	12	1.6	5 650	6 650	575	680	18 000	27 000	—	BK0912	0.0045	IR 6× 9×12
	16	12	—	5 300	4 450	540	455	18 000	27 000	HMK0912	—	0.0087	IR 6× 9×16
	16	16	—	7 400	6 850	755	700	18 000	27 000	HMK0916	—	0.0120	—
10	14	10	—	4 500	5 100	460	520	16 000	24 000	HK1010	—	0.0038	IR 7×10×10.5
	14	10	1.6	4 500	5 100	460	520	16 000	24 000	—	BK1010	0.0042	IR 7×10×10.5
	14	12	—	5 900	7 250	605	735	16 000	24 000	HK1012	—	0.0045	IR 7×10×16
	14	12	1.6	5 900	7 250	605	735	16 000	24 000	—	BK1012	0.0050	IR 7×10×16
	14	15	—	7 100	9 150	725	935	16 000	24 000	HK1015	—	0.0056	IR 7×10×16
	14	15	1.6	7 100	9 150	725	935	16 000	24 000	—	BK1015	0.0062	IR 7×10×16
	17	10	—	4 250	3 450	435	350	16 000	24 000	HMK1010	—	0.0079	IR 7×10×10.5
	17	12	—	5 600	4 850	570	495	16 000	24 000	HMK1012	—	0.0094	IR 7×10×16

Note 1) Bearing with inner ring is represented by HK+IR. (Refer to "Inner Ring Dimensions Table" on page B-117.)
 EX. HK1012 + IR7×10×16.5

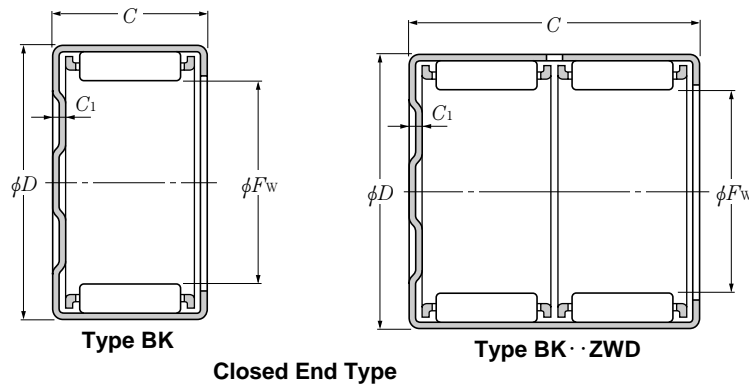

F_w 10~16mm

Boundary dimensions	Basic load ratings				Limiting speeds		Bearing numbers		Mass kg (approx.)	Appropriate ¹⁾ inner ring (as a reference)			
	mm				r/min		open end design	closed end design					
	F_w	D	C 0 -0.2	C_1 max	dynamic N	static kgf					grease	oil	
				C_r	C_{or}	C_r	C_{or}						
10	17	15	—	7 400	6 950	755	710	16 000	24 000	HMK1015	—	0.0120	IR 7×10×16
	17	20	—	10 200	10 500	1 040	1 070	16 000	24 000	HMK1020	—	0.0160	—
12	16	10	—	5 050	6 250	515	635	13 000	20 000	HK1210	—	0.0046	IR 8×12×10.5
	16	10	1.6	5 050	6 250	515	635	13 000	20 000	—	BK1210	0.0052	IR 8×12×10.5
	18	12	—	6 600	7 300	675	745	13 000	20 000	HK1212	—	0.0091	IR 8×12×12.5
	18	12	2.7	6 600	7 300	675	745	13 000	20 000	—	BK1212	0.0100	IR 8×12×12.5
	19	12	—	7 100	6 900	725	705	13 000	20 000	HMK1212	—	0.0110	IR 8×12×12.5
	19	15	—	9 400	9 900	955	1 010	13 000	20 000	HMK1215	—	0.0140	IR 9×12×16
	19	20	—	12 300	14 000	1 260	1 430	13 000	20 000	HMK1220	—	0.0180	—
13	19	25	—	15 300	18 600	1 560	1 890	13 000	20 000	HMK1225	—	0.0230	—
	19	12	—	6 950	7 900	705	805	12 000	18 000	HK1312	—	0.0100	IR10×13×12.5
14	19	12	2.7	6 950	7 900	705	805	12 000	18 000	—	BK1312	0.0110	IR10×13×12.5
	20	12	—	7 200	8 500	735	865	11 000	17 000	HK1412	—	0.0110	IR10×14×13
	20	12	2.7	7 200	8 500	735	865	11 000	17 000	—	BK1412	0.0120	IR10×14×13
	20	16	—	10 700	14 000	1 090	1 430	11 000	17 000	HK1416	—	0.0150	—
	20	16	2.7	10 700	14 000	1 090	1 430	11 000	17 000	—	BK1416	0.0160	—
	22	16	—	11 500	12 000	1 180	1 220	11 000	17 000	HMK1416	—	0.0190	IR10×14×20
15	22	20	—	14 600	16 200	1 490	1 650	11 000	17 000	HMK1420	—	0.0240	—
	21	12	—	7 500	9 100	765	930	11 000	16 000	HK1512	—	0.0110	IR12×15×12.5
	21	12	2.7	7 500	9 100	765	930	11 000	16 000	—	BK1512	0.0130	IR12×15×12.5
	21	16	—	10 700	14 400	1 090	1 470	11 000	16 000	HK1516	—	0.0150	IR12×15×16.5
	21	16	2.7	10 700	14 400	1 090	1 470	11 000	16 000	—	BK1516	0.0170	IR12×15×16.5
	21	22	—	12 900	18 200	1 310	1 860	11 000	16 000	HK1522ZWD	—	0.0200	IR12×15×22.5
	21	22	2.7	12 900	18 200	1 310	1 860	11 000	16 000	—	BK1522ZWD	0.0220	IR12×15×22.5
	22	10	—	6 100	6 000	620	610	11 000	16 000	HMK1510	—	0.0110	IR10×15×12.5
	22	12	—	7 950	8 450	810	860	11 000	16 000	HMK1512	—	0.0130	IR12×15×12.5
	22	15	—	10 900	12 700	1 120	1 300	11 000	16 000	HMK1515	—	0.0160	IR12×15×16
	22	20	—	14 900	18 900	1 510	1 920	11 000	16 000	HMK1520	—	0.0220	IR12×15×22.5
22	25	—	18 500	25 000	1 880	2 550	11 000	16 000	HMK1525	—	0.0270	—	
16	22	12	—	7 750	9 700	795	990	10 000	15 000	HK1612	—	0.0120	IR12×16×13

Note 1) Bearing with inner ring is represented by HK+IR. (Refer to "Inner Ring Dimensions Table" on page B-117, B118.)
EX. HK1312 + IR10×13×12.5

Type HK, Type HK · · ZWD
 Type HMK
 Type BK, Type BK · · ZWD

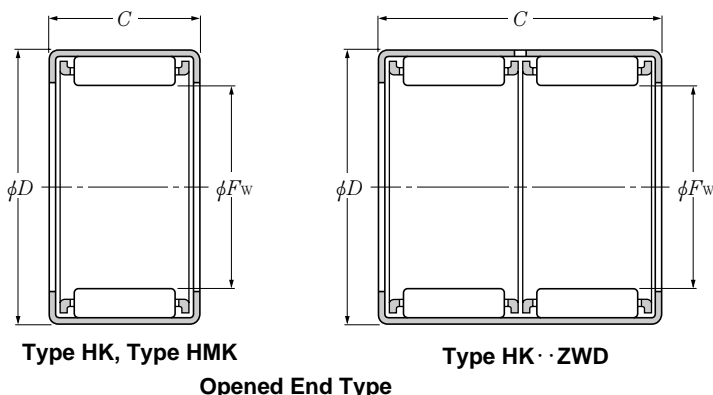

F_w 16~20mm

Boundary dimensions				Basic load ratings				Limiting speeds		Bearing numbers		Mass	Appropriate ¹⁾ inner ring
F_w	mm			dynamic	static	dynamic	static	r/min		open end	closed end	kg (approx.)	(as a reference)
	D	C 0 -0.2	C_1 max	N	N	kgf	kgf	grease	oil	design	design		
16	22	12	2.7	7 750	9 700	795	990	10 000	15 000	—	BK1612	0.014	IR12×16×13
	22	16	—	11 100	15 300	1 130	1 560	10 000	15 000	HK1616	—	0.016	IR12×16×20
	22	16	2.7	11 100	15 300	1 130	1 560	10 000	15 000	—	BK1616	0.018	IR12×16×20
	22	22	—	13 300	19 400	1 360	1 980	10 000	15 000	HK1622ZWD	—	0.022	—
	22	22	2.7	13 300	19 400	1 360	1 980	10 000	15 000	—	BK1622ZWD	0.023	—
	24	16	—	12 400	13 500	1 260	1 370	10 000	15 000	HMK1616	—	0.021	IR12×16×20
	24	20	—	15 600	18 200	1 590	1 860	10 000	15 000	HMK1620	—	0.027	IR12×16×22
17	23	12	—	8 500	11 100	865	1 130	9 500	14 000	HK1712	—	0.012	—
	23	12	2.7	8 500	11 100	865	1 130	9 500	14 000	—	BK1712	0.015	—
	24	15	—	12 100	15 000	1 230	1 530	9 500	14 000	HMK1715	—	0.018	IR14×17×17
	24	20	—	15 200	20 000	1 540	2 040	9 500	14 000	HMK1720C	—	0.024	IR12×17×20.5
	24	25	—	19 300	27 400	1 970	2 790	9 500	14 000	HMK1725B	—	0.030	IR12×17×25.5
18	24	12	—	8 300	10 900	845	1 110	8 500	13 000	HK1812	—	0.013	IR15×18×12.5
	24	12	2.7	8 300	10 900	845	1 110	8 500	13 000	—	BK1812	0.015	IR15×18×12.5
	24	16	—	11 800	17 300	1 210	1 760	8 500	13 000	HK1816	—	0.018	IR15×18×16.5
	24	16	2.7	11 800	17 300	1 210	1 760	8 500	13 000	—	BK1816	0.020	IR15×18×16.5
	25	13	—	10 200	12 200	1 040	1 240	8 500	13 000	HMK1813	—	0.016	IR15×18×16
	25	15	—	12 000	15 100	1 220	1 540	8 500	13 000	HMK1815	—	0.019	IR15×18×16
	25	17	—	13 800	18 000	1 400	1 830	8 500	13 000	HMK1817	—	0.021	IR15×18×17.5
	25	19	—	15 500	20 900	1 580	2 130	8 500	13 000	HMK1819	—	0.024	IR15×18×20.5
	25	20	—	16 300	22 300	1 660	2 280	8 500	13 000	HMK1820	—	0.025	IR15×18×20.5
	25	25	—	20 300	29 600	2 070	3 000	8 500	13 000	HMK1825	—	0.031	IR15×18×25.5
19	27	16	—	13 900	16 300	1 410	1 660	8 500	13 000	HMK1916	—	0.025	IR15×19×20
	27	20	—	17 500	22 100	1 790	2 250	8 500	13 000	HMK1920	—	0.031	—
20	26	12	—	9 250	13 000	945	1 330	8 000	12 000	HK2012C	—	0.014	IR15×20×13
	26	12	2.7	9 250	13 000	945	1 330	8 000	12 000	—	BK2012	0.017	IR15×20×13
	26	16	—	13 000	20 100	1 320	2 050	8 000	12 000	HK2016	—	0.019	IR17×20×16.5
	26	16	2.7	13 000	20 100	1 320	2 050	8 000	12 000	—	BK2016	0.022	IR17×20×16.5
	26	20	—	16 400	27 100	1 670	2 760	8 000	12 000	HK2020C	—	0.024	IR17×20×20.5
	26	20	2.7	16 400	27 100	1 670	2 760	8 000	12 000	—	BK2020C	0.027	IR17×20×20.5

Note 1) Bearing with inner ring is represented by HK+IR. (Refer to "Inner Ring Dimensions Table" on page B-118, B119.)
 EX. HK1812 + IR15×18×12.5

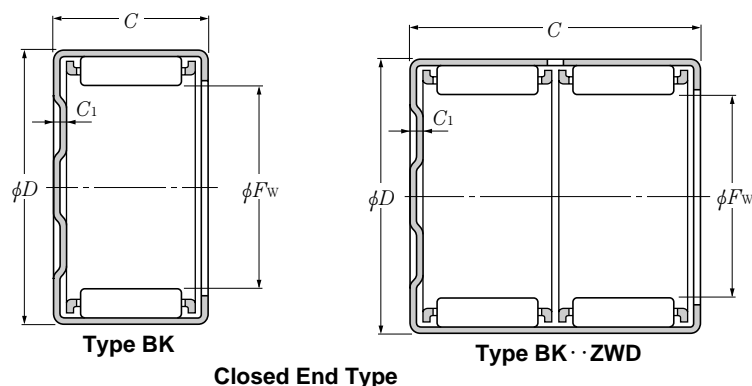

F_w 20~25mm

Boundary dimensions				Basic load ratings				Limiting speeds		Bearing numbers		Mass	Appropriate ¹⁾ inner ring
F_w	mm			N		kgf		grease	oil	open end design	closed end design	kg (approx.)	(as a reference)
	D	C 0 -0.2	C_1 max	C_r	C_{or}	C_r	C_{or}						
20	26	30	—	22 200	40 000	2 270	4 100	8 000	12 000	HK2030ZWD	—	0.035	IR17×20×30.5
	26	30	2.7	22 200	40 000	2 270	4 100	8 000	12 000	—	BK2030ZWD	0.037	IR17×20×30.5
	27	15	—	13 000	17 300	1 330	1 760	8 000	12 000	HMK2015	—	0.021	IR17×20×16.5
	27	20	—	17 700	25 600	1 800	2 610	8 000	12 000	HMK2020	—	0.027	IR17×20×20.5
	27	25	—	22 000	34 000	2 240	3 450	8 000	12 000	HMK2025	—	0.034	IR15×20×26
	27	30	—	26 100	42 000	2 660	4 300	8 000	12 000	HMK2030	—	0.041	IR17×20×30.5
21	29	16	—	15 300	19 100	1 560	1 940	7 500	11 000	HMK2116	—	0.027	IR17×21×20
	29	20	—	19 400	25 800	1 970	2 630	7 500	11 000	HMK2120	—	0.033	—
22	28	12	—	9 750	14 300	995	1 460	7 500	11 000	HK2212	—	0.013	IR17×22×13
	28	12	2.7	9 750	14 300	995	1 460	7 500	11 000	—	BK2212	0.015	IR17×22×13
	28	16	—	13 600	22 100	1 390	2 250	7 500	11 000	HK2216C	—	0.021	IR17×22×18
	28	16	2.7	13 600	22 100	1 390	2 250	7 500	11 000	—	BK2216	0.024	IR17×22×18
	28	20	—	17 200	29 800	1 760	3 050	7 500	11 000	HK2220C	—	0.026	IR17×22×20.5
	28	20	2.7	17 200	29 800	1 760	3 050	7 500	11 000	—	BK2220	0.030	IR17×22×20.5
	29	10	—	8 400	10 100	855	1 030	7 500	11 000	HMK2210	—	0.015	IR17×22×13
	29	15	—	13 400	18 500	1 370	1 890	7 500	11 000	HMK2215	—	0.022	IR17×22×16D
	29	20	—	18 200	27 400	1 860	2 790	7 500	11 000	HMK2220	—	0.030	IR17×22×20.5
	29	25	—	23 600	38 500	2 410	3 900	7 500	11 000	HMK2225	—	0.037	IR17×22×26
24	31	20	—	18 800	29 100	1 910	2 970	6 500	10 000	HMK2420	—	0.032	—
	31	28	—	26 000	44 500	2 650	4 500	6 500	10 000	HMK2428	—	0.045	IR20×24×28.5
25	32	12	—	11 800	16 300	1 200	1 660	6 500	9 500	HK2512	—	0.021	IR20×25×12.5
	32	12	2.7	11 800	16 300	1 200	1 660	6 500	9 500	—	BK2512	0.023	IR20×25×12.5
	32	16	—	15 900	24 000	1 620	2 450	6 500	9 500	HK2516	—	0.027	IR20×25×17
	32	16	2.7	15 900	24 000	1 620	2 450	6 500	9 500	—	BK2516	0.031	IR20×25×17
	32	20	—	20 300	33 000	2 070	3 350	6 500	9 500	HK2520	—	0.034	IR20×25×20.5
	32	20	2.7	20 300	33 000	2 070	3 350	6 500	9 500	—	BK2520	0.039	IR20×25×20.5
	32	26	—	26 400	46 000	2 690	4 700	6 500	9 500	HK2526	—	0.045	IR20×25×26.5
	32	26	2.7	26 400	46 000	2 690	4 700	6 500	9 500	—	BK2526	0.049	IR20×25×26.5
32	38	—	35 000	65 500	3 550	6 700	6 500	9 500	HK2538ZWD	—	0.065	IR20×25×38.5	

Note 1) Bearing with inner ring is represented by HK+IR. (Refer to "Inner Ring Dimensions Table" on page B-119, B120.)
EX. HK2512 + IR20×25×12.5

Type HK, Type HK · · ZWD
 Type HMK, Type HMK · · ZWD
 Type BK, Type BK · · ZWD

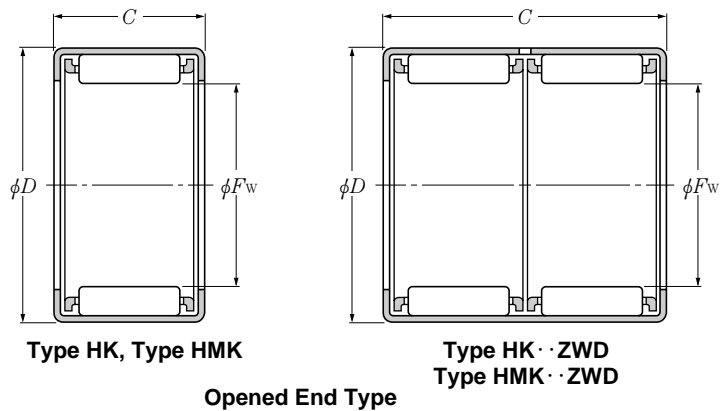

F_w 25~30mm

Boundary dimensions				Basic load ratings				Limiting speeds		Bearing numbers		Mass	Appropriate ¹⁾ inner ring
F_w	mm			dynamic	static	dynamic	static	r/min		open end design	closed end design	kg (approx.)	(as a reference)
	D	C 0 -0.2	C_1 max	N	N	kgf	kgf	grease	oil				
				C_r	C_{or}	C_r	C_{or}						
25	32	38	2.7	35 000	65 500	3 550	6 700	6 500	9 500	—	BK2538ZWD	0.069	IR20×25×38.5
	33	10	—	9 150	10 400	935	1 060	6 500	9 500	HMK2510	—	0.019	IR20×25×12.5
	33	15	—	15 200	19 900	1 550	2 030	6 500	9 500	HMK2515C	—	0.029	IR20×25×16
	33	20	—	21 800	31 500	2 220	3 200	6 500	9 500	HMK2520	—	0.039	IR20×25×20.5
	33	25	—	26 700	41 000	2 720	4 200	6 500	9 500	HMK2525	—	0.048	IR20×25×26.5
	33	30	—	32 500	53 000	3 300	5 400	6 500	9 500	HMK2530	—	0.058	IR20×25×32
26	34	16	—	17 200	23 300	1 750	2 380	6 000	9 000	HMK2616	—	0.032	IR22×26×20
	34	20	—	21 800	31 500	2 220	3 200	6 000	9 000	HMK2620	—	0.040	—
28	35	16	—	17 300	27 600	1 760	2 820	5 500	8 500	HK2816	—	0.030	IR22×28×17
	35	16	2.7	17 300	27 600	1 760	2 820	5 500	8 500	—	BK2816	0.034	IR22×28×17
	35	20	—	21 300	36 000	2 170	3 700	5 500	8 500	HK2820	—	0.038	IR22×28×20.5
	35	20	2.7	21 300	36 000	2 170	3 700	5 500	8 500	—	BK2820	0.043	IR22×28×20.5
	37	20	—	23 600	32 500	2 410	3 350	5 500	8 500	HMK2820	—	0.049	IR22×28×20.5
	37	30	—	35 000	54 500	3 600	5 550	5 500	8 500	HMK2830	—	0.073	—
29	38	20	—	24 600	35 000	2 510	3 550	5 500	8 500	HMK2920	—	0.050	—
	38	30	—	34 500	54 000	3 550	5 550	5 500	8 500	HMK2930	—	0.075	—
30	37	12	—	13 000	19 500	1 320	1 990	5 500	8 000	HK3012	—	0.024	IR25×30×12.5
	37	12	2.7	13 000	19 500	1 320	1 990	5 500	8 000	—	BK3012	0.028	IR25×30×12.5
	37	16	—	18 100	30 000	1 850	3 050	5 500	8 000	HK3016	—	0.032	IR25×30×17
	37	16	2.7	18 100	30 000	1 850	3 050	5 500	8 000	—	BK3016C	0.037	IR25×30×17
	37	20	—	22 300	39 500	2 280	4 000	5 500	8 000	HK3020	—	0.040	IR25×30×20.5
	37	20	2.7	22 300	39 500	2 280	4 000	5 500	8 000	—	BK3020	0.047	IR25×30×20.5
	37	26	—	28 500	54 000	2 910	5 500	5 500	8 000	HK3026	—	0.053	IR25×30×26.5
	37	26	2.7	29 100	55 000	2 960	5 650	5 500	8 000	—	BK3026	0.059	IR25×30×26.5
	37	38	—	38 500	78 500	3 900	8 000	5 500	8 000	HK3038ZWD	—	0.076	IR25×30×38.5
	37	38	2.7	38 500	78 500	3 900	8 000	5 500	8 000	—	BK3038ZWD	0.083	IR25×30×38.5
	40	13	—	14 100	17 100	1 430	1 750	5 500	8 000	HMK3013	—	0.040	IR25×30×16
	40	15	—	17 100	22 100	1 750	2 250	5 500	8 000	HMK3015	—	0.044	IR25×30×16
40	20	—	24 200	34 500	2 470	3 500	5 500	8 000	HMK3020	—	0.058	IR25×30×20.5	
40	25	—	31 000	47 000	3 150	4 800	5 500	8 000	HMK3025	—	0.073	IR25×30×26.5	

Note 1) Bearing with inner ring is represented by HK+IR. (Refer to "Inner Ring Dimensions Table" on page B-120.)
 EX. HK2820 + IR22×28×20.5

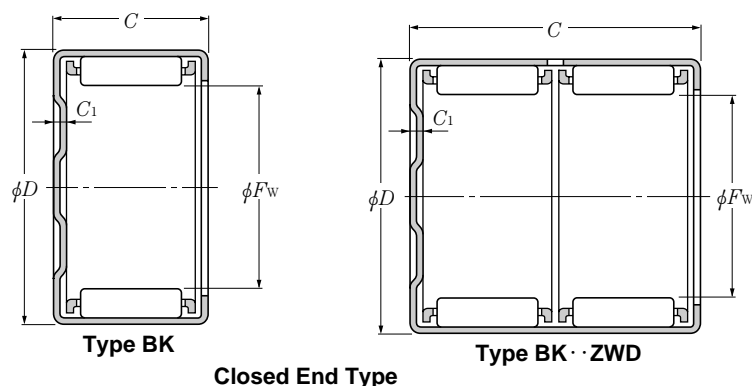

F_w 30~40mm

Boundary dimensions	Basic load ratings				Limiting speeds		Bearing numbers		Mass kg (approx.)	Appropriate ¹⁾ inner ring (as a reference)			
	mm				r/min		open end design	closed end design					
	F_w	D	C 0 -0.2	C_1 max	dynamic N	static kgf					grease	oil	
				C_r	C_{or}	C_r	C_{or}						
30	40	30	—	36 000	57 500	3 700	5 850	5 500	8 000	HMK3030	—	0.087	IR25×30×32
32	42	20	—	27 500	38 000	2 800	3 850	5 000	7 500	HMK3220	—	0.062	—
	42	30	—	41 500	64 500	4 250	6 550	5 000	7 500	HMK3230	—	0.092	—
35	42	12	—	14 000	22 800	1 430	2 320	4 700	7 000	HK3512	—	0.028	—
	42	12	2.7	14 000	22 800	1 430	2 320	4 700	7 000	—	BK3512	0.033	—
	42	16	—	19 700	35 000	2 000	3 600	4 700	7 000	HK3516	—	0.037	—
	42	16	2.7	19 700	35 000	2 000	3 600	4 700	7 000	—	BK3516	0.044	—
	42	20	—	24 800	47 500	2 530	4 850	4 700	7 000	HK3520	—	0.046	—
	42	20	2.7	24 800	47 500	2 530	4 850	4 700	7 000	—	BK3520	0.055	—
	45	12	—	14 900	17 600	1 520	1 800	4 700	7 000	HMK3512	—	0.040	—
	45	15	—	20 200	26 200	2 060	2 670	4 700	7 000	HMK3515	—	0.050	—
	45	20	—	28 400	40 500	2 890	4 100	4 700	7 000	HMK3520	—	0.067	—
	45	25	—	36 000	54 500	3 650	5 550	4 700	7 000	HMK3525	—	0.083	—
37	47	20	—	29 300	43 000	2 990	4 350	4 300	6 500	HMK3720	—	0.070	—
	47	30	—	44 500	73 000	4 550	7 450	4 300	6 500	HMK3730	—	0.105	—
38	48	15	—	21 700	29 300	2 210	2 990	4 300	6 500	HMK3815	—	0.054	—
	48	20	—	30 500	45 000	3 100	4 600	4 300	6 500	HMK3820	—	0.072	—
	48	25	—	38 500	61 000	3 900	6 250	4 300	6 500	HMK3825	—	0.090	—
	48	30	—	46 000	77 000	4 700	7 850	4 300	6 500	HMK3830	—	0.107	IR32×38×32
	48	45	—	62 000	113 000	6 300	11 500	4 300	6 500	HMK3845ZWD	—	0.161	—
40	47	12	—	15 100	26 000	1 540	2 660	4 000	6 000	HK4012	—	0.031	IR35×40×12.5
	47	12	2.7	15 100	26 000	1 540	2 660	4 000	6 000	—	BK4012	0.038	IR35×40×12.5
	47	16	—	21 100	40 000	2 150	4 100	4 000	6 000	HK4016	—	0.041	IR35×40×17
	47	16	2.7	21 100	40 000	2 150	4 100	4 000	6 000	—	BK4016	0.051	IR35×40×17
	47	20	—	25 900	52 500	2 650	5 350	4 000	6 000	HK4020	—	0.052	IR35×40×20.5
	47	20	2.7	25 900	52 500	2 650	5 350	4 000	6 000	—	BK4020	0.064	IR35×40×20.5
	50	15	—	23 100	32 500	2 350	3 300	4 000	6 000	HMK4015	—	0.056	IR35×40×17
	50	20	—	32 500	50 000	3 300	5 100	4 000	6 000	HMK4020	—	0.075	IR35×40×20.5
	50	25	—	41 000	67 500	4 150	6 900	4 000	6 000	HMK4025	—	0.094	—

Note 1) Bearing with inner ring is represented by HK+IR. (Refer to "Inner Ring Dimensions Table" on page B-121, B122.)
EX. HK4012 + IR35×40×12.5

Type HK

Type HMK, Type HMK · ZWD

Type BK

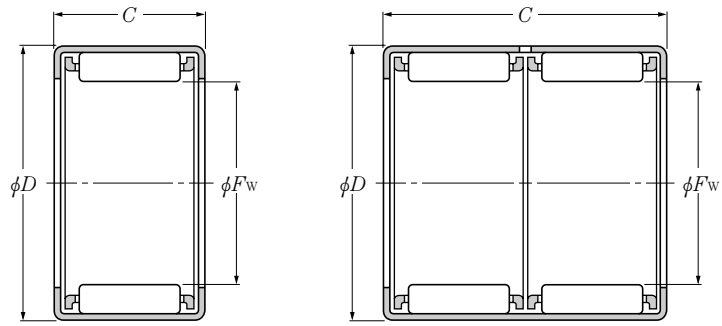

Type HK, Type HMK

Type HMK · ZWD

Opened End Type

F_w 40~50mm

Boundary dimensions	Basic load ratings				Limiting speeds		Bearing numbers		Mass kg (approx.)	Appropriate ¹⁾ inner ring (as a reference)			
	mm				r/min		open end design	closed end design					
	F_w	D	C 0 -0.2	C_1 max	dynamic N	static kgf					grease	oil	
				C_r	C_{or}	C_r	C_{or}						
40	50	30	—	49 000	85 000	5 000	8 700	4 000	6 000	HMK4030	—	0.112	IR35×40×34
	50	40	—	58 500	107 000	5 950	10 900	4 000	6 000	HMK4040ZWD	—	0.150	—
45	52	16	—	21 600	43 000	2 210	4 400	3 700	5 500	HK4516	—	0.046	IR40×45×17
	52	16	2.7	21 600	43 000	2 210	4 400	3 700	5 500	—	BK4516	0.058	IR40×45×17
	52	20	—	27 600	59 000	2 810	6 000	3 700	5 500	HK4520	—	0.058	IR40×45×20.5
	52	20	2.7	27 600	59 000	2 810	6 000	3 700	5 500	—	BK4520	0.072	IR40×45×20.5
	55	20	—	33 000	53 000	3 350	5 400	3 700	5 500	HMK4520	—	0.083	IR40×45×20.5
	55	25	—	41 500	71 500	4 250	7 300	3 700	5 500	HMK4525	—	0.104	IR40×45×26.5
	55	30	—	49 500	90 000	5 050	9 150	3 700	5 500	HMK4530	—	0.125	IR40×45×34
	55	40	—	59 500	113 000	6 050	11 500	3 700	5 500	HMK4540ZWD	—	0.167	—
50	58	20	—	31 500	63 000	3 200	6 450	3 200	4 800	HK5020	—	0.072	IR40×50×22
	58	20	2.7	31 500	63 000	3 200	6 450	3 200	4 800	—	BK5020	0.087	IR40×50×22
	58	25	—	38 500	82 000	3 900	8 400	3 200	4 800	HK5025	—	0.090	IR45×50×25.5
	58	25	2.7	38 500	82 000	3 900	8 400	3 200	4 800	—	BK5025	0.109	IR45×50×25.5
	62	12	—	18 200	23 600	1 860	2 410	3 200	4 800	HMK5012	—	0.067	—
	62	15	—	25 900	37 000	2 650	3 800	3 200	4 800	HMK5015	—	0.084	—
	62	20	—	37 500	60 000	3 850	6 100	3 200	4 800	HMK5020	—	0.112	IR40×50×22
	62	25	—	48 000	82 500	4 900	8 450	3 200	4 800	HMK5025	—	0.140	IR45×50×25.5
	62	30	—	58 500	105 000	5 950	10 700	3 200	4 800	HMK5030B	—	0.168	IR45×50×32
	62	40	—	70 000	134 000	7 150	13 600	3 200	4 800	HMK5040ZWD	—	0.224	—
62	45	—	79 000	156 000	8 050	15 900	3 200	4 800	HMK5045ZWB	—	0.252	—	

Note 1) Bearing with inner ring is represented by HK+IR. (Refer to "Inner Ring Dimensions Table" on page B-122, B123.)
EX. HK4516 + IR40×45×17

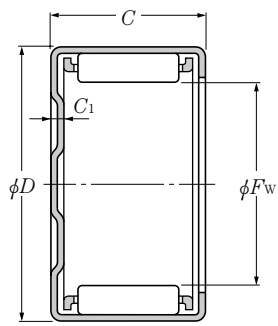

Type BK
Closed End Type

- Type HK··L
- Type HMK··L
- Type HK··LL
- Type HMK··LL
- Type BK··L

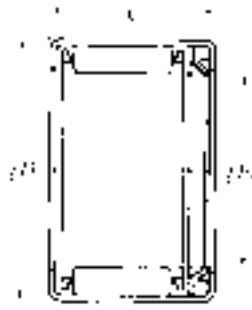

Type HK··L, Type HMK··L
(Opened end and single-side seal type)

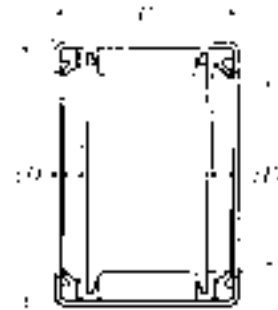

Type HK··LL, Type HMK··LL
(Opened end and double-side seal type)

F_w 8~25mm

Boundary dimensions					Basic load ratings				Limiting speeds r/min grease	Bearing numbers		
F_w	D	C_1 mm 0 -0.2	C_2 0 -0.2	C_3 max	dynamic N C_r	static C_{or}	dynamic kgf C_r	static C_{or}		open end single seal	open end double seal	closed end single seal
8	15	12	14	—	3 800	2 870	390	293	10 000	HMK0812L	HMK0814LL	—
10	17	12	14	—	4 250	3 450	435	350	10 000	HMK1012L	HMK1014LL	—
12	18	14	16	2.7	6 600	7 300	675	745	10 000	HK 1214L	HK 1216LL	BK1214L
	19	14	16	—	7 100	6 900	725	705	10 000	HMK1214L	HMK1216LL	—
14	20	14	16	2.7	7 200	8 500	735	865	10 000	HK 1414L	HK 1416LL	BK1414L
	22	19	22	—	11 500	12 000	1 180	1 220	10 000	HMK1419L	HMK1422LL	—
15	21	14	16	2.7	7 500	9 100	765	930	10 000	HK 1514L	HK 1516LL	BK1514L
	22	13	16	—	6 100	6 000	620	610	10 000	HMK1513L	HMK1516LL	—
	22	18	21	—	10 900	12 700	1 120	1 300	10 000	HMK1518L	HMK1521LL	—
16	22	14	16	2.7	7 750	9 700	795	990	10 000	HK 1614L	HK 1616LL	BK1614L
	24	23	26	—	15 600	18 200	1 590	1 860	10 000	HMK1623L	HMK1626LL	—
17	24	18	21	—	12 100	15 000	1 230	1 530	9 500	HMK1718L	HMK1721LL	—
18	24	14	16	2.7	8 300	10 900	845	1 110	9 000	HK 1814L	HK 1816LL	BK1814L
	25	18	21	—	12 000	15 100	1 220	1 540	9 000	HMK1818L	HMK1821LL	—
	25	20	23	—	13 800	18 000	1 400	1 830	9 000	HMK1820L	HMK1823LL	—
19	27	19	22	—	13 900	16 300	1 410	1 660	8 500	HMK1919L	HMK1922LL	—
20	26	—	16	—	9 250	13 000	945	1 330	8 000	—	HK 2016LL	—
	26	18	20	2.7	13 000	20 100	1 320	2 050	8 000	HK 2018L	HK 2020LL	BK2018L
	27	18	21	—	13 000	17 300	1 330	1 760	8 000	HMK2018L	HMK2021LL	—
	27	23	26	—	17 700	25 600	1 800	2 610	8 000	HMK2023L	HMK2026LL	—
22	28	—	16	—	9 750	14 300	995	1 460	7 500	—	HK 2216LL	—
	28	18	20	2.7	13 600	22 100	1 390	2 250	7 500	HK 2218L	HK 2220LL	BK2218L
	29	18	21	—	13 400	18 500	1 370	1 890	7 500	HMK2218L	HMK2221LL	—
	29	23	26	—	18 200	27 400	1 860	2 790	7 500	HMK2223L	HMK2226LL	—
24	31	23	26	—	18 800	29 100	1 910	2 970	6 500	HMK2423L	HMK2426LL	—
25	32	—	16	—	11 800	16 300	1 200	1 660	6 500	—	HK 2516LL	—
	32	18	20	2.7	15 900	24 000	1 620	2 450	6 500	HK 2518L	HK 2520LL	BK2518L

Note 1) Bearing with inner ring is represented by HK+IR. (Refer to "Inner Ring Dimensions Table" on page B-117 to B119.)
EX. HK1416LL + IR10×14×20



Type BK·L
(Closed end and single-side seal type)

open end single seal	Mass kg (approx.)		Appropriate ¹⁾ inner ring (as a reference)	
	open end double seal	closed end single seal	single seal	double seal
0.0071	0.0075	—	IR 5×8×16	IR 5× 8×16
0.0084	0.0089	—	IR 7×10×16	IR 7×10×16
0.011	0.0120	0.012	IR 9×12×16	—
0.011	0.0120	—	IR 9×12×16	—
0.012	0.0140	0.014	IR10×14×16	IR10×14×20
0.020	0.0210	—	IR10×14×20	—
0.013	0.0140	0.014	IR12×15×16.5	IR12×15×16.5
0.014	0.0150	—	IR12×15×16	IR12×15×16.5
0.017	0.0180	—	IR12×15×22.5	IR12×15×22.5
0.013	0.0150	0.015	IR12×16×16	IR12×16×20
0.028	0.0290	—	—	—
0.019	0.0200	—	IR12×17×20.5	IR12×17×25.5
0.015	0.0170	0.017	IR15×18×16	IR15×18×17.5
0.020	0.0210	—	IR15×18×20.5	IR15×18×25.5
0.023	0.0240	—	IR15×18×20.5	IR15×18×25.5
0.027	0.0290	—	IR15×19×20	—
—	0.0190	—	—	IR15×20×18
0.021	0.0240	0.024	IR17×20×20	IR17×20×20.5
0.022	0.0240	—	IR17×20×20	IR15×20×23
0.029	0.0310	—	IR15×20×26	IR17×20×30.5
—	0.0200	—	—	IR17×22×18
0.024	0.0260	0.027	IR17×22×20.5	IR17×22×23
0.024	0.0260	—	IR17×22×20.5	IR17×22×23
0.032	0.0330	—	IR17×22×26	—
0.035	0.0370	—	—	IR20×24×28.5
—	0.0270	—	—	IR20×25×18D
0.031	0.0330	0.035	IR20×25×20	IR20×25×23

- Type HK··L
- Type HMK··L
- Type HK··LL
- Type HMK··LL
- Type BK··L

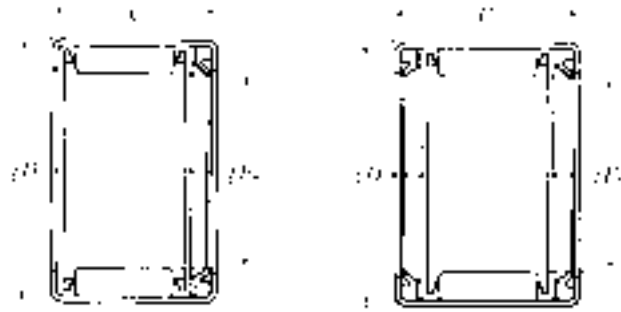

Type HK··L, Type HMK··L
(Opened end and single-side seal type)

Type HK··LL, Type HMK··LL
(Opened end and double-side seal type)

F_w 25~50mm

F_w	Boundary dimensions				Basic load ratings				Limiting speeds r/min grease	Bearing numbers		
	D	C_1 0 -0.2	C_2 0 -0.2	C_3 max	dynamic N	static	dynamic kgf	static		open end single seal	open end double seal	closed end single seal
					C_r	C_{or}	C_r	C_{or}				
25	33	18	21	—	15 800	21 000	1 610	2 140	6 500	HMK2518L	HMK2521LL	—
	33	23	26	—	21 800	31 500	2 220	3 200	6 500	HMK2523L	HMK2526LL	—
28	35	—	20	—	17 300	27 600	1 760	2 820	5 500	—	HK 2820LL	—
	37	23	26	—	23 600	32 500	2 410	3 350	5 500	HMK2823L	HMK2826LL	—
30	37	—	16	—	13 000	19 500	1 320	1 990	5 500	—	HK 3016LL	—
	37	18	20	2.7	18 100	30 000	1 850	3 050	5 500	HK 3018L	HK 3020LL	BK3018L
	40	23	26	—	24 200	34 500	2 470	3 500	5 500	HMK3023L	HMK3026LL	—
	40	28	31	—	31 000	47 000	3 150	4 800	5 500	HMK3028L	HMK3031LL	—
32	42	23	26	—	27 500	38 000	2 800	3 850	5 000	HMK3223L	HMK3226LL	—
35	42	—	16	—	14 000	22 800	1 430	2 320	4 600	—	HK 3516LL	—
	42	18	20	2.7	19 700	35 000	2 000	3 600	4 600	HK 3518L	HK 3520LL	BK3518L
	45	18	21	—	20 200	26 200	2 060	2 670	4 600	HMK3518L	HMK3521LL	—
	45	28	31	—	36 000	54 500	3 650	5 550	4 600	HMK3528L	HMK3531LL	—
38	48	28	31	—	38 500	61 000	3 900	6 250	4 200	HMK3828L	HMK3831LL	—
40	47	—	16	—	15 100	26 000	1 540	2 660	4 000	—	HK 4016LL	—
	47	18	20	2.7	21 100	40 000	2 150	4 100	4 000	HK 4018L	HK 4020LL	BK4018L
	50	18	21	—	23 100	32 500	2 350	3 300	4 000	HMK4018L	HMK4021LL	—
	50	28	31	—	41 000	67 500	4 150	6 900	4 000	HMK4028L	HMK4031LL	—
45	52	18	20	2.7	21 600	43 000	2 210	4 400	3 600	HK 4518L	HK 4520LL	BK4518L
	55	23	26	—	33 000	53 000	3 350	5 400	3 600	HMK4523L	HMK4526LL	—
50	58	22	24	2.7	31 500	63 000	3 200	6 450	3 200	HK 5022L	HK 5024LL	BK5022L
	62	28	31	—	48 000	82 500	4 900	8 450	3 200	HMK5028L	HMK5031LL	—

Note 1) Bearing with inner ring is represented by HK+IR. (Refer to "Inner Ring Dimensions Table" on page B-119 to B123.)
EX. HK5022L + IR45×50×25



Type BK · L
(Closed end and single-side seal type)

open end single seal	Mass kg (approx.)		Appropriate ¹⁾ inner ring (as a reference)	
	open end double seal	closed end single seal	single seal	double seal
0.031	0.034	—	IR20×25×20	IR20×25×23
0.041	0.043	—	IR20×25×26.5	IR20×25×26.5
—	0.037	—	—	IR22×28×23
0.051	0.054	—	—	IR22×28×30
—	0.027	—	—	IR25×30×18D
0.037	0.039	0.045	IR25×30×20	IR25×30×23
0.061	0.064	—	IR25×30×26	IR25×30×26.5
0.076	0.078	—	IR25×30×30	IR25×30×32
0.065	0.069	—	—	IR28×32×30
—	0.036	—	—	—
0.037	0.040	0.047	—	—
0.053	0.056	—	—	—
0.086	0.089	—	—	—
0.094	0.098	—	IR32×38×32	IR32×38×32
—	0.041	—	—	IR35×40×17
0.047	0.050	0.062	IR35×40×20	—
0.060	0.063	—	IR35×40×20	—
0.097	0.100	—	IR35×40×30	IR32×40×36
0.054	0.057	0.072	IR40×45×20	—
0.087	0.091	—	IR40×45×26.5	IR40×45×26.5
0.086	0.089	0.104	IR45×50×25	IR45×50×25.5
0.144	0.149	—	IR45×50×32	IR45×50×32

Inch series

Type DCL

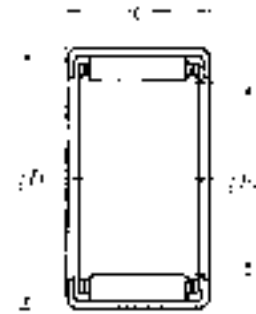

F_w 6.350~15.875mm

F_w	Boundary dimensions mm ($\frac{1}{25.4}$ mm)		Basic load ratings				Limiting speeds		Bearing numbers	Mass kg (approx.)	Appropriate ¹⁾ inner ring (as a reference)
	D	C -0.2	dynamic N C_r	static N C_{or}	dynamic kgf C_r	static kgf C_{or}	grease r/min	oil r/min			
6.350 ($\frac{1}{4}$)	11.112($\frac{7}{16}$)	6.350($\frac{1}{4}$)	1 580	1 110	161	113	25 000	38 000	DCL 44T2	0.0022	—
	11.112($\frac{7}{16}$)	7.938($\frac{5}{16}$)	2 160	1 670	221	170	25 000	38 000	DCL 45T2	0.0033	—
	11.112($\frac{7}{16}$)	11.112($\frac{7}{16}$)	3 550	3 150	360	320	25 000	38 000	DCL 47T2	0.0038	—
7.938 ($\frac{5}{16}$)	12.700($\frac{1}{2}$)	7.938($\frac{5}{16}$)	2 940	2 610	300	266	20 000	30 000	DCL 55	0.0032	—
	12.700($\frac{1}{2}$)	9.525($\frac{3}{8}$)	3 900	3 750	400	385	20 000	30 000	DCL 56	0.0039	—
	12.700($\frac{1}{2}$)	11.112($\frac{7}{16}$)	4 800	4 950	490	505	20 000	30 000	DCL 57	0.0048	—
	12.700($\frac{1}{2}$)	14.288($\frac{9}{16}$)	6 500	7 250	665	740	20 000	30 000	DCL 59	0.0058	—
9.525 ($\frac{3}{8}$)	14.288($\frac{9}{16}$)	7.938($\frac{5}{16}$)	3 100	2 910	315	297	17 000	25 000	DCL 65	0.0037	—
	14.288($\frac{9}{16}$)	9.525($\frac{3}{8}$)	4 100	4 200	420	430	17 000	25 000	DCL 66	0.0045	—
	14.288($\frac{9}{16}$)	12.700($\frac{1}{2}$)	5 900	6 650	600	675	17 000	25 000	DCL 68	0.0065	—
	14.288($\frac{9}{16}$)	15.875($\frac{5}{8}$)	7 500	9 050	765	925	17 000	25 000	DCL 610	0.0075	—
11.112 ($\frac{7}{16}$)	15.875($\frac{5}{8}$)	12.700($\frac{1}{2}$)	6 450	7 800	660	795	15 000	22 000	DCL 78	0.0068	—
12.700 ($\frac{1}{2}$)	17.462($\frac{11}{16}$)	7.938($\frac{5}{16}$)	3 550	3 700	360	380	13 000	19 000	DCL 85	0.0047	—
	17.462($\frac{11}{16}$)	9.525($\frac{3}{8}$)	4 700	5 350	480	550	13 000	19 000	DCL 86	0.0057	—
	17.462($\frac{11}{16}$)	11.112($\frac{7}{16}$)	5 800	7 050	590	715	13 000	19 000	DCL 87	0.0066	—
	17.462($\frac{11}{16}$)	12.700($\frac{1}{2}$)	6 700	8 500	685	865	13 000	19 000	DCL 88	0.0080	—
	17.462($\frac{11}{16}$)	15.875($\frac{5}{8}$)	8 550	11 600	870	1 180	13 000	19 000	DCL 810	0.0095	—
	17.462($\frac{11}{16}$)	19.050($\frac{3}{4}$)	10 400	14 900	1 060	1 520	13 000	19 000	DCL 812	0.0120	—
14.288 ($\frac{9}{16}$)	19.050($\frac{3}{4}$)	7.938($\frac{5}{16}$)	3 800	4 250	390	430	11 000	17 000	DCL 95	0.0052	—
	19.050($\frac{3}{4}$)	9.525($\frac{3}{8}$)	5 050	6 150	515	625	11 000	17 000	DCL 96	0.0063	MI-060908
	19.050($\frac{3}{4}$)	11.112($\frac{7}{16}$)	6 250	8 000	635	815	11 000	17 000	DCL 97	0.0073	MI-060908
	19.050($\frac{3}{4}$)	12.700($\frac{1}{2}$)	7 200	9 650	735	985	11 000	17 000	DCL 98	0.0086	MI-060908
	19.050($\frac{3}{4}$)	15.875($\frac{5}{8}$)	9 200	13 200	935	1 350	11 000	17 000	DCL 910	0.0110	—
	19.050($\frac{3}{4}$)	19.050($\frac{3}{4}$)	11 200	17 000	1 140	1 730	11 000	17 000	DCL 912	0.0130	—
15.875 ($\frac{5}{8}$)	20.638($\frac{13}{16}$)	7.938($\frac{5}{16}$)	4 050	4 750	415	485	10 000	15 000	DCL 105	0.0075	—
	20.638($\frac{13}{16}$)	11.112($\frac{7}{16}$)	6 650	9 000	680	915	10 000	15 000	DCL 107	0.0080	—
	20.638($\frac{13}{16}$)	12.700($\frac{1}{2}$)	7 700	10 800	785	1 110	10 000	15 000	DCL 108	0.0091	—
	20.638($\frac{13}{16}$)	15.875($\frac{5}{8}$)	9 800	14 800	1 000	1 510	10 000	15 000	DCL1010	0.0130	MI-061012
	20.638($\frac{13}{16}$)	19.050($\frac{3}{4}$)	11 900	19 000	1 220	1 940	10 000	15 000	DCL1012	0.0140	MI-061012

Note 1) Bearing with inner ring is represented by DCL-MI. (Refer to Inner Ring Dimension Table on page B-129.)
EX. DCL96 + MI-060908

Remarks: Manufacture of the closed end type bearings under this Table is also available.

F_w 15.875~25.400mm

Boundary dimensions			Basic load ratings				Limiting speeds		Bearing numbers	Mass kg (approx.)	Appropriate ¹⁾ inner ring (as a reference)
F_w	mm ($\frac{1}{25.4}$ mm)		dynamic	static	dynamic	static	r/min				
	D	C -0.2	N		kgf		grease	oil			
			C_r	C_{or}	C_r	C_{or}					
15.875($\frac{5}{8}$)	20.638($\frac{13}{16}$)	22.225($\frac{7}{8}$)	14 100	23 500	1 430	2 400	10 000	15 000	DCL1014	0.0160	MI-061016
		22.225($\frac{7}{8}$)	5 700	7 650	585	780	9 500	14 000	DCL 116	0.0075	—
17.462($\frac{11}{16}$)	22.225($\frac{7}{8}$)	12.700($\frac{1}{2}$)	8 150	12 000	830	1 230	9 500	14 000	DCL 118	0.0110	—
	22.225($\frac{7}{8}$)	15.875($\frac{5}{8}$)	10 400	16 400	1 060	1 680	9 500	14 000	DCL1110	0.0130	—
	22.225($\frac{7}{8}$)	19.050($\frac{3}{4}$)	12 600	21 100	1 290	2 150	9 500	14 000	DCL1112	0.0160	—
19.050($\frac{3}{4}$)	25.400(1)	9.525($\frac{3}{8}$)	6 450	6 950	660	705	8 500	13 000	DCL 126	0.0110	—
	25.400(1)	12.700($\frac{1}{2}$)	9 800	11 900	1 000	1 210	8 500	13 000	DCL 128	0.0140	MI-081210
	25.400(1)	15.875($\frac{5}{8}$)	12 900	16 800	1 310	1 720	8 500	13 000	DCL1210	0.0170	MI-081210
	25.400(1)	19.050($\frac{3}{4}$)	15 900	22 100	1 620	2 250	8 500	13 000	DCL1212	0.0210	MI-081212
	25.400(1)	22.225($\frac{7}{8}$)	19 000	27 700	1 930	2 830	8 500	13 000	DCL1214	0.0260	MI-081216
	25.400(1)	25.400(1)	21 700	33 000	2 210	3 350	8 500	13 000	DCL1216	0.0300	MI-081216
20.638($\frac{13}{16}$)	26.988($1\frac{1}{16}$)	9.525($\frac{3}{8}$)	6 950	7 800	710	795	8 000	12 000	DCL 136	0.0120	—
	26.988($1\frac{1}{16}$)	12.700($\frac{1}{2}$)	10 600	13 400	1 080	1 370	8 000	12 000	DCL 138	0.0160	—
	26.988($1\frac{1}{16}$)	15.875($\frac{5}{8}$)	13 900	19 000	1 410	1 930	8 000	12 000	DCL1310	0.0200	—
	26.988($1\frac{1}{16}$)	19.050($\frac{3}{4}$)	17 100	24 900	1 750	2 540	8 000	12 000	DCL1312	0.0230	—
	26.988($1\frac{1}{16}$)	22.225($\frac{7}{8}$)	20 400	31 500	2 080	3 200	8 000	12 000	DCL1314	0.0280	—
	26.988($1\frac{1}{16}$)	25.400(1)	23 400	37 000	2 380	3 800	8 000	12 000	DCL1316	0.0320	—
	26.988($1\frac{1}{16}$)	31.750($1\frac{1}{4}$)	29 000	49 000	2 960	5 000	8 000	12 000	DCL1320	0.0400	—
22.225($\frac{7}{8}$)	28.575($1\frac{1}{8}$)	9.525($\frac{3}{8}$)	7 150	8 300	730	845	7 500	11 000	DCL 146	0.0130	MI-101406
	28.575($1\frac{1}{8}$)	12.700($\frac{1}{2}$)	10 900	14 200	1 110	1 450	7 500	11 000	DCL 148	0.0170	MI-101408
	28.575($1\frac{1}{8}$)	19.050($\frac{3}{4}$)	17 600	26 400	1 800	2 700	7 500	11 000	DCL1412	0.0250	MI-101412
	28.575($1\frac{1}{8}$)	22.225($\frac{7}{8}$)	21 000	33 000	2 140	3 400	7 500	11 000	DCL1414	0.0340	MI-101416
	28.575($1\frac{1}{8}$)	25.400(1)	24 100	39 500	2 450	4 000	7 500	11 000	DCL1416	0.0340	MI-101416
23.812($\frac{15}{16}$)	30.162($1\frac{3}{16}$)	15.875($\frac{5}{8}$)	14 600	21 300	1 490	2 170	6 500	10 000	DCL1510	0.0230	—
	30.162($1\frac{3}{16}$)	25.400(1)	24 700	41 500	2 520	4 250	6 500	10 000	DCL1516	0.0360	—
25.400(1)	31.750($1\frac{1}{4}$)	9.525($\frac{3}{8}$)	7 550	9 250	770	940	6 500	9 500	DCL 166	0.0140	—
	31.750($1\frac{1}{4}$)	12.700($\frac{1}{2}$)	11 500	15 800	1 170	1 610	6 500	9 500	DCL 168	0.0190	—
	31.750($1\frac{1}{4}$)	19.050($\frac{3}{4}$)	18 600	29 500	1 890	3 000	6 500	9 500	DCL1612	0.0310	MI-121612
	31.750($1\frac{1}{4}$)	22.225($\frac{7}{8}$)	22 100	37 000	2 260	3 750	6 500	9 500	DCL1614	0.0340	MI-121616

Note 1) Bearing with inner ring is represented by DCL-MI. (Refer to Inner Ring Dimension Table on page B-129.)
EX. DCL128 + MI-081210

Remarks: Manufacture of the closed end type bearings under this Table is also available.

Inch series

Type DCL

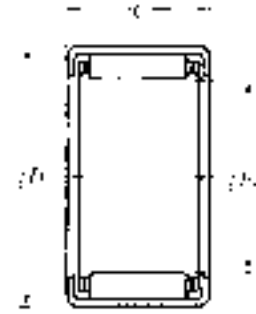

F_w 25.400~41.275mm

F_w	Boundary dimensions		Basic load ratings				Limiting speeds		Bearing numbers	Mass kg (approx.)	Appropriate ¹⁾ inner ring (as a reference)
	mm ($\frac{1}{25.4}$ mm)		dynamic	static	dynamic	static	r/min				
	D	C -0.2	C_r	C_{or}	C_r	C_{or}	grease	oil			
25.400(1)	31.750(1 $\frac{1}{4}$)	25.400(1)	25 400	44 000	2 590	4 500	6 500	9 500	DCL1616	0.038	MI-121616
	31.750(1 $\frac{1}{4}$)	31.750(1 $\frac{1}{4}$)	31 500	58 000	3 200	5 900	6 500	9 500	DCL1620	0.048	—
26.988(1 $\frac{1}{16}$)	33.338(1 $\frac{5}{16}$)	15.875($\frac{5}{8}$)	15 900	24 600	1 620	2 510	6 000	9 000	DCL1710	0.025	—
28.575(1 $\frac{1}{8}$)	34.925(1 $\frac{3}{8}$)	9.525($\frac{3}{8}$)	8 150	10 600	830	1 080	5 500	8 500	DCL 186	0.016	MI-141808
	34.925(1 $\frac{3}{8}$)	12.700($\frac{1}{2}$)	12 400	18 200	1 260	1 850	5 500	8 500	DCL 188	0.021	MI-141808
	34.925(1 $\frac{3}{8}$)	19.050($\frac{3}{4}$)	20 100	34 000	2 050	3 450	5 500	8 500	DCL1812	0.032	MI-141812
	34.925(1 $\frac{3}{8}$)	25.400(1)	27 400	50 500	2 790	5 150	5 500	8 500	DCL1816	0.043	MI-141816
	34.925(1 $\frac{3}{8}$)	31.750(1 $\frac{1}{4}$)	34 000	66 500	3 450	6 800	5 500	8 500	DCL1820	0.053	MI-141820
30.162(1 $\frac{3}{16}$)	38.100(1 $\frac{1}{2}$)	25.400(1)	33 000	54 000	3 350	5 500	5 500	8 000	DCL1916	0.057	—
31.750(1 $\frac{1}{4}$)	38.100(1 $\frac{1}{2}$)	12.700($\frac{1}{2}$)	12 500	19 000	1 280	1 940	5 000	7 500	DCL 208	0.023	—
	38.100(1 $\frac{1}{2}$)	15.875($\frac{5}{8}$)	16 400	27 000	1 670	2 750	5 000	7 500	DCL2010	0.029	—
	38.100(1 $\frac{1}{2}$)	19.050($\frac{3}{4}$)	20 300	35 500	2 070	3 600	5 000	7 500	DCL2012	0.036	—
	38.100(1 $\frac{1}{2}$)	25.400(1)	27 700	53 000	2 830	5 400	5 000	7 500	DCL2016	0.047	—
	38.100(1 $\frac{1}{2}$)	31.750(1 $\frac{1}{4}$)	34 500	70 000	3 500	7 100	5 000	7 500	DCL2020	0.058	—
34.925(1 $\frac{3}{8}$)	41.275(1 $\frac{5}{8}$)	12.700($\frac{1}{2}$)	13 400	21 400	1 360	2 180	4 700	7 000	DCL 228	0.027	—
	41.275(1 $\frac{5}{8}$)	19.050($\frac{3}{4}$)	21 700	40 000	2 210	4 050	4 700	7 000	DCL2212	0.038	—
	41.275(1 $\frac{5}{8}$)	25.400(1)	29 600	59 500	3 000	6 050	4 700	7 000	DCL2216	0.051	—
	41.275(1 $\frac{5}{8}$)	31.750(1 $\frac{1}{4}$)	36 500	78 500	3 750	8 000	4 700	7 000	DCL2220	0.064	—
38.100(1 $\frac{1}{2}$)	47.625(1 $\frac{7}{8}$)	12.700($\frac{1}{2}$)	17 100	22 800	1 750	2 320	4 300	6 500	DCL 248	0.043	—
	47.625(1 $\frac{7}{8}$)	15.875($\frac{5}{8}$)	21 000	29 700	2 150	3 050	4 300	6 500	DCL2410	0.054	—
	47.625(1 $\frac{7}{8}$)	19.050($\frac{3}{4}$)	26 600	40 000	2 710	4 100	4 300	6 500	DCL2412	0.065	—
	47.625(1 $\frac{7}{8}$)	22.225($\frac{7}{8}$)	32 000	50 500	3 250	5 150	4 300	6 500	DCL2414	0.076	MI-202416
	47.625(1 $\frac{7}{8}$)	25.400(1)	36 500	60 500	3 750	6 200	4 300	6 500	DCL2416	0.087	MI-202416
	47.625(1 $\frac{7}{8}$)	31.750(1 $\frac{1}{4}$)	46 500	82 000	4 750	8 350	4 300	6 500	DCL2420	0.107	MI-202420
41.275(1 $\frac{5}{8}$)	50.800(2)	12.700($\frac{1}{2}$)	18 000	24 900	1 840	2 540	4 000	6 000	DCL 268	0.046	MI-222610
	50.800(2)	15.875($\frac{5}{8}$)	22 100	32 500	2 260	3 300	4 000	6 000	DCL2610	0.058	MI-222610
	50.800(2)	25.400(1)	38 500	66 500	3 950	6 800	4 000	6 000	DCL2616	0.106	—
	50.800(2)	31.750(1 $\frac{1}{4}$)	49 000	90 000	5 000	9 150	4 000	6 000	DCL2620	0.116	MI-212620

Note 1) Bearing with inner ring is represented by DCL-MI. (Refer to Inner Ring Dimension Table on page B-130.)
EX. DCL2414 + MI-202416

Remarks: Manufacture of the closed end type bearings under this Table is also available.

F_w 44.450~50.800mm

Boundary dimensions			Basic load ratings				Limiting speeds		Bearing numbers	Mass kg (approx.)	Appropriate ¹⁾ inner ring (as a reference)
F_w	mm ($\frac{1}{25.4}$ mm)		dynamic N	static	dynamic kgf	static	r/min				
	D	C -0.2	C_r	C_{or}	C_r	C_{or}	grease	oil			
44.450(1 $\frac{3}{4}$)	53.975(2 $\frac{1}{8}$)	19.050($\frac{3}{4}$)	29 200	47 500	2 980	4 850	3 700	5 500	DCL2812	0.074	MI-242812
	53.975(2 $\frac{1}{8}$)	25.400(1)	40 500	72 000	4 100	7 350	3 700	5 500	DCL2816	0.099	MI-242816
	53.975(2 $\frac{1}{8}$)	38.100(1 $\frac{1}{2}$)	62 000	126 000	6 350	12 800	3 700	5 500	DCL2824	0.149	—
47.625(1 $\frac{7}{8}$)	57.150(2 $\frac{1}{4}$)	12.700($\frac{1}{2}$)	19 700	29 200	2 000	2 980	3 300	5 000	DCL 308	0.053	—
	57.150(2 $\frac{1}{4}$)	15.875($\frac{5}{8}$)	24 200	38 000	2 460	3 900	3 300	5 000	DCL3010	0.066	—
	57.150(2 $\frac{1}{4}$)	25.400(1)	42 000	78 000	4 300	7 950	3 300	5 000	DCL3016	0.106	—
50.800(2)	60.325(2 $\frac{3}{8}$)	12.700($\frac{1}{2}$)	20 400	31 500	2 080	3 200	3 100	4 700	DCL 328	0.056	—
	60.325(2 $\frac{3}{8}$)	25.400(1)	44 000	83 500	4 450	8 550	3 100	4 700	DCL3216	0.112	—
	60.325(2 $\frac{3}{8}$)	31.750(1 $\frac{1}{4}$)	55 500	113 000	5 650	11 500	3 100	4 700	DCL3220	0.140	—
	60.325(2 $\frac{3}{8}$)	38.100(1 $\frac{1}{2}$)	67 500	146 000	6 850	14 800	3 100	4 700	DCL3224	0.168	—

Note 1) Bearing with inner ring is represented by DCL-MI. (Refer to Inner Ring Dimension Table on page B-130.)
EX. DCL2816 + MI-242816

Remarks: Manufacture of the closed end type bearings under this Table is also available.

Type HCK

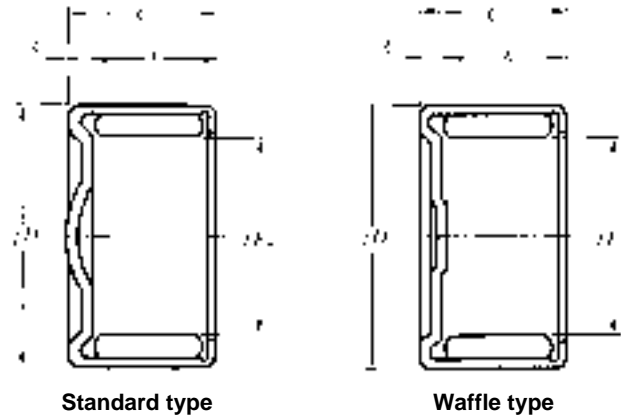

F_w 10~20mm

Boundary dimensions					Basic load ratings				Bearing numbers		Mass kg (approx.)
mm					dynamic	static	dynamic	static	standard type	waffle type	
F_w	D	C	b	C_1	C_r N	C_{or}	C_r kgf	C_{or}			
10	15	9.35	7.6	1.75	6 200	9 250	635	940	—	HCK1015	0.007
11.656	17.1	11.85	9.6	2.25	8 850	13 800	905	1 400	HCK1217	—	0.011
13	19	11.85	9.6	2.25	10 000	15 000	1 020	1 530	HCK1319	—	0.013
14	20	11.85	9.6	2.25	10 500	16 600	1 070	1 690	HCK1420	—	0.014
16	22	12.85	10.6	2.25	12 200	20 700	1 240	2 110	HCK1622	—	0.017
18	24	13.85	11.6	2.25	13 900	25 300	1 420	2 580	HCK1824	—	0.021
18	24.6	13.85	11.6	2.25	13 900	25 300	1 420	2 580	HCK1825	—	0.025
20	27.9	15.82	13.1	2.72	17 800	31 000	1 810	3 150	HCK2028	—	0.037

Machined Ring Needle Roller Bearings



Machined Ring Needle Roller Bearings

The machined ring of this bearing type contains needle rollers and a cage. And the outer ring and the needle rollers are inseparable from each other by means of double-side ribs on the outer ring or side plates.

Because of its machined (solid) outer ring enabling to make it more rigid and to thereby upgrade the bearing accuracy, this bearing type is suitable for an application

requiring high speed, high load and high running accuracy. These machined ring needle roller bearings are available in two types -- one without inner ring and another with inner ring -- considering the case of using a shaft as the direct raceway surface without using inner ring.

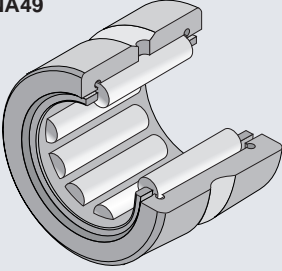
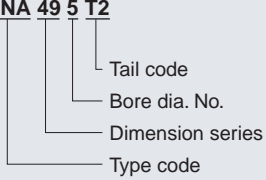
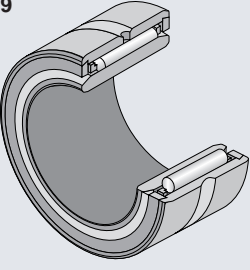
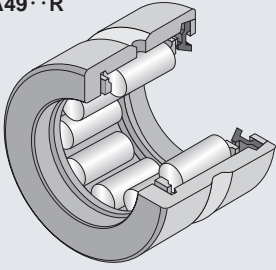
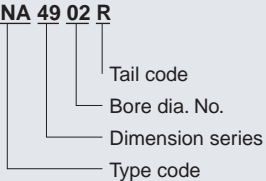
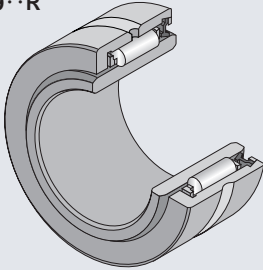
Bearing type	Applied shaft diameter (mm)	Composition of nominal bearing number	Remarks
Type RNA49 	$\phi 7 \sim \phi 12$	RNA 49 5 T2 	Bearing with tail code T2 uses a polyamide resin cage and, therefore, it shall be used at allowable temperature 120°C and, under continuous running, at 100°C and less.
Type NA49 	$\phi 5 \sim \phi 9$	[Tail code] T2: Resin cage	The dimension series is in compliance with JIS B 1512 or ISO 15.
Type RNA49 · R 	$\phi 14 \sim \phi 490$ With seal $\phi 14 \sim \phi 58$	RNA 49 02 R 	Bearing with seal type (Tail code: L or LL) - synthetic rubber seal built in at single side or double sides is internally filled up with lithium soap base grease.
Type NA49 · R 	$\phi 10 \sim \phi 440$ With seal $\phi 10 \sim \phi 50$	[Tail code] R: Rib type L: Single-side seal type LL: Double-side seal type	The sealed bearing type shall be used within the temperature range of -25 to 100°C to prevent deterioration of the seal and filled-up grease. The dimension series is in compliance with JIS B 15 or ISO 15.

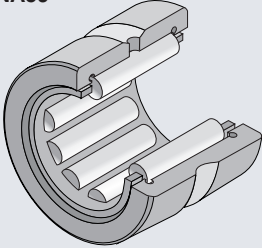
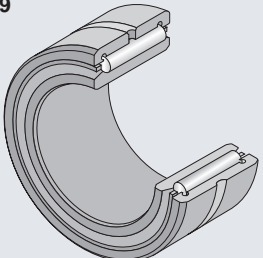
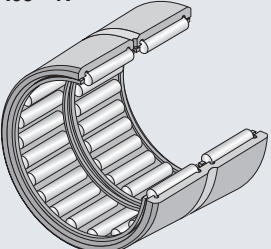
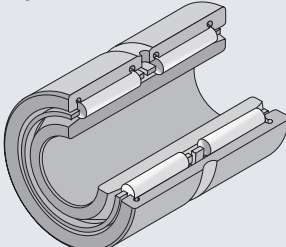
Bearing type	Applied shaft diameter (mm)	Composition of nominal bearing number	Remarks
Type RNA59 	$\phi 20 \sim \phi 160$	RNA 59 02 Type No. Dimension series Type code	The dimension series is in compliance with JIS B 1512 or ISO 15.
Type NA59 	$\phi 15 \sim \phi 140$	NA 59 / 22 Type No. Dimension series Type code	
Type RNA69 · R 	$\phi 16 \sim \phi 35$ $\phi 40 \sim \phi 110$ Built-in cage double-row type	RNA 69 01 R Tail code Type No. Dimension series Type code	
Type NA49 · R 	$\phi 12 \sim \phi 30$ $\phi 32 \sim \phi 95$ Built-in cage double-row type	NA 69 / 22 Type No. Dimension series Type code	

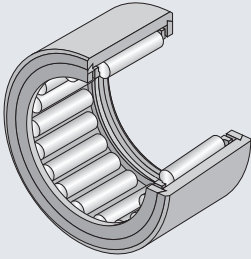
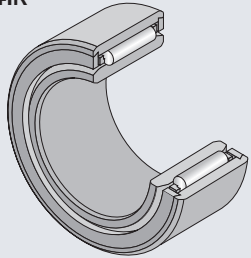
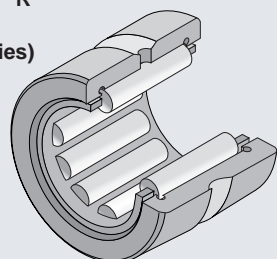
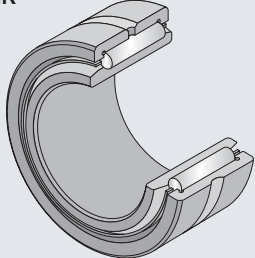
Bearing type	Applied shaft diameter (mm)	Composition of nominal bearing number	Remarks
Type NK 	$\phi 5 \sim \phi 12$	NK 7 / 10 T2 Type code — NK Inscribed circle diameter — 7 Width — 10 Tail code — T2	Bearing with tail code T2 uses a polyamide resin cage and, therefore, it shall be used at allowable temperature 120°C and, under continuous running, at 100°C and less.
Type NK+IR 	$\phi 5 \sim \phi 9$	NK24 / 16R + IR 20 × 24 × 16 Type code — NK Bore diameter — 24 Outer diameter — 16R Width — 16 Tail code — IR	
Type NK · · R Type MR (Inch series) 	NK $\phi 14 \sim \phi 165$ MR $\phi 15.875 \sim \phi 234.95$	MR 10 18 12 Type code — MR Inscribed circle dia. code — 10 Outer diameter code — 18 Width code — 12	
NK · · Type R+IR Type MR+MI (Inch series) 	NK · · R+IR $\phi 10 \sim \phi 150$	MR101812 + MI - 06 10 12 Type code — MR Inscribed circle dia. code — 10 Outer diameter code — 18 Width code — 12 Tail code — MI Bore diameter code — 06	

Bearing Tolerances

The dimensional accuracy, profile accuracy and running accuracy of machined ring needle roller bearings are specified in JIS B 1514 (Accuracy of Rolling Bearings). (Refer to Section 4 "Bearing Tolerances", **Table 4.3** on page A-26.) Although the accuracy of NTN standard bearings conforms to JIS Class-0, NTN can also supply bearings conforming to JIS Class-6, -5 and -4.

Feel free to contact NTN for the further detail of these bearings.

The dimensional tolerances for the roller inscribed circle diameters (F_w) of bearing **type NK, RNA** and **MR** conform to ISO Tolerance Range Class-F6. Refer to this ISO Tolerance Class

in selecting shaft diameter and radial clearance.

Radial clearance and bearing fits

NTN machined ring needle roller bearings (with inner ring) are all manufactured within the radial clearance range specified in **Table 5.1** of Subsection 5.1 "Radial Clearance in Bearings" (page A-30). Because of the narrow non-interchangeable clearance range, the bearings shipped after adjusted to a specific non-interchangeable clearance must be installed with the clearance remained unchanged.

The respective dimensional tolerances for shaft and housing bore sizes on/in which bearing with inner ring is press-fitted are per **Table 6.3** of 6.4 "Recommended Bearing Fits" (page A-34) which specifies them according to load characteristic, load magnitude, and shaft and housing bore sizes. The profile accuracy and

surface roughness of shaft and housing to be applied are as specified in **Table 7.3** of 7.3 "Shaft and Housing Accuracy" (page A-39).

A shaft is used as the direct raceway surface for a bearing without inner ring and, in this case, the shaft diameter (raceway diameter) tolerance is per **Table 1** specifying the tolerances according to each running clearance. And K7 tolerance generally in broad use is applied as the dimensional tolerance for the housing bore. Feel free to contact NTN for application of housing bore tolerance other than K7.

For the profile accuracy, surface roughness and hardness of a shaft acting as the raceway surface, refer to **Table 7.4** of 7.4 "Raceway Surface Accuracy"(page A-39).

Table 1 Shaft diameter (raceway diameter) tolerance

Roller inscribed circle dia. F_w mm		Tolerance range class for shaft		
Over	incl.	Smaller than ordinary clearance	Ordinary class	Larger than ordinary clearance
	80	k5	h5	f6
80	160	k5	g5	f6
160	180	k5	g5	e6
180	200	j5	g5	e6
200	250	j5	f6	e6
250	315	h5	f6	e6
315	400	g5	f6	d6

Dimension of oil hole in outer ring

The outer ring is provided with an oil hole and an oil groove to facilitate oil lubrication to bearing. (but excluding Type NK with roller inscribed circle diameter (F_w) of 12mm and less.)

Table 2 shows the oil hole dimension every outer ring diameter.

Table 2 Oil hole dimension

Outer ring outer diameter		Oil hole dia. (mm)	Number of oil hole
Over	incl.		
—	20	2.0	1
20	40	2.5	1
40	80	3.0	1
80	200	3.5	1
200	350	4.0	1
350	—	5.0	1

Mounting relations

In the case of raceway with an oil hole, the bearing must be installed so the oil hole locates within the non-load area. In addition, any bearing with inner ring must be used within the allowable stroking value (s) (with the rollers retained within the effective contact length range of inner ring).

For the allowable stroking value (s), refer to Fig. 1 and applicable "Dimensions Table".

The inner ring and outer ring of machined ring needle roller bearing must be positioned in axial direction by shoulder or snap ring in this case. For the shoulder dimension and corner roundness (r_a) of the shaft and the housing are as specified in applicable "Dimensions Table".

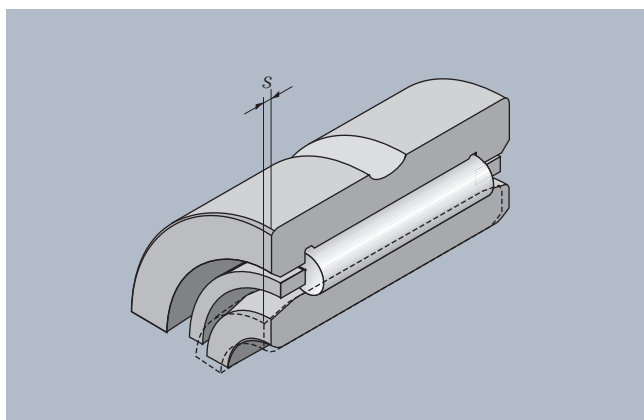
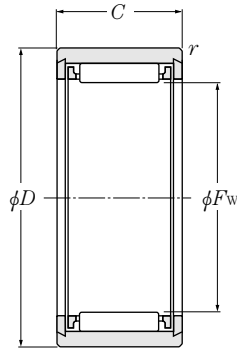

Fig. 1

Without Inner Ring

Type RNA49
Type RNA59
Type RNA69
Type NK



Type NK
($F_w \leq 12\text{mm}$)

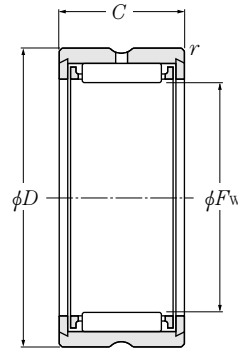

Type RNA49 ($F_w \leq 12\text{mm}$)

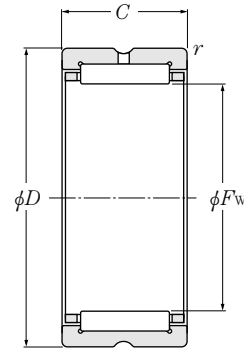

Type RNA49 · R ($F_w \geq 14\text{mm}$)
Type RNA59
Type RNA69 · R
Type NK · R ($F_w \geq 14\text{mm}$)

F_w 5~16mm

Boundary dimensions				Basic load ratings				Limiting speeds		Bearing numbers	Abutment dimensions		Mass kg (approx.)
mm				dynamic	static	dynamic	static	r/min			D_a	r_{as}	
F_w	D	C	r_s min ¹⁾	C_r	C_{or}	C_r	C_{or}	grease	oil		max	max	
5 ^{+0.018 +0.010}	10	10	0.15	2 640	2 190	269	224	27 000	40 000	NK5/10T2	6.5	0.15	0.0031
	10	12	0.15	2 720	2 250	277	230	27 000	40 000	NK5/12T2	6.5	0.15	0.0037
6 ^{+0.018 +0.010}	12	10	0.15	2 660	2 280	272	233	25 000	37 000	NK6/10T2	7.5	0.15	0.0047
	12	12	0.15	3 400	3 150	345	320	25 000	37 000	NK6/12T2	7.5	0.15	0.0057
7 ^{+0.022 +0.013}	13	10	0.15	2 670	2 350	272	239	23 000	34 000	RNA495T2	8.5	0.15	0.0055
	14	10	0.3	2 670	2 350	272	239	23 000	34 000	NK7/10T2	8.5	0.3	0.0069
	14	12	0.3	3 400	3 200	345	330	23 000	34 000	NK7/12T2	8.5	0.3	0.0082
8 ^{+0.022 +0.013}	15	10	0.15	3 150	3 000	320	305	21 000	32 000	RNA496	9.5	0.15	0.0073
	15	12	0.3	4 000	4 100	410	420	21 000	32 000	NK8/12T2	9.5	0.3	0.0087
	15	16	0.3	4 850	5 200	495	535	21 000	32 000	NK8/16T2	9.5	0.3	0.0120
9 ^{+0.022 +0.013}	16	12	0.3	4 550	5 000	465	510	20 000	30 000	NK9/12T2	10.5	0.3	0.0100
	16	16	0.3	5 500	6 400	560	650	20 000	30 000	NK9/16T2	10.5	0.3	0.0130
	17	10	0.15	3 600	3 650	365	375	20 000	30 000	RNA497	10.5	0.15	0.0095
10 ^{+0.022 +0.013}	17	12	0.3	4 550	5 100	460	520	19 000	28 000	NK10/12T2	11.5	0.3	0.0100
	17	16	0.3	5 450	6 450	555	660	19 000	28 000	NK10/16	11.5	0.3	0.0130
	19	11	0.15	4 300	3 950	435	405	19 000	28 000	RNA498	12	0.15	0.0130
12 ^{+0.027 +0.016}	19	12	0.3	5 000	6 100	510	620	17 000	26 000	NK12/12	13.5	0.3	0.0130
	19	16	0.3	6 000	7 700	615	785	17 000	26 000	NK12/16	13.5	0.3	0.0160
	20	11	0.3	4 850	4 900	495	500	17 000	26 000	RNA499	14	0.3	0.0130
14 ^{+0.027 +0.016}	22	13	0.3	8 600	9 200	875	935	16 000	24 000	RNA4900R	20	0.3	0.0170
	22	16	0.3	10 300	11 500	1 050	1 170	16 000	24 000	NK14/16R	20	0.3	0.0210
	22	20	0.3	13 000	15 600	1 330	1 590	16 000	24 000	NK14/20R	20	0.3	0.0260
15 ^{+0.027 +0.016}	23	16	0.3	10 900	12 700	1 110	1 290	15 000	23 000	NK15/16R	21	0.3	0.0220
	23	20	0.3	13 800	17 200	1 410	1 750	15 000	23 000	NK15/20R	21	0.3	0.0270
16 ^{+0.027 +0.016}	24	13	0.3	9 550	10 900	975	1 110	15 000	23 000	RNA4901R	22	0.3	0.0170
	24	16	0.3	12 200	14 900	1 240	1 520	15 000	23 000	NK16/16R	22	0.3	0.0220
	24	20	0.3	14 600	18 800	1 490	1 920	15 000	23 000	NK16/20R	22	0.3	0.0280
	24	22	0.3	15 400	20 000	1 570	2 040	15 000	23 000	RNA6901R	22	0.3	0.0310

Note 1) Allowable minimum chamfer dimension r .

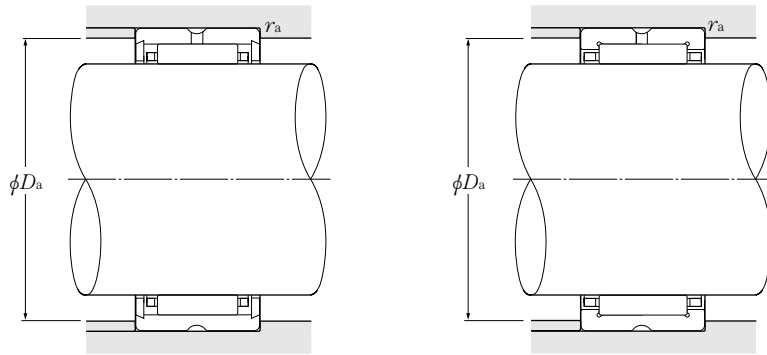

F_w 17~28mm

Boundary dimensions				Basic load ratings				Limiting speeds		Bearing numbers	Abutment dimensions		Mass kg (approx.)
mm				dynamic	static	dynamic	static	r/min			D_a	r_{as}	
F_w	D	C	r_s min ¹⁾	N		kgf		grease	oil	max	max		
17 ^{+0.027} _{+0.016}	25	16	0.3	12 100	15 000	1 240	1 530	15 000	22 000	NK17/16R	23	0.3	0.024
	25	20	0.3	15 400	20 400	1 570	2 080	15 000	22 000	NK17/20R	23	0.3	0.030
18 ^{+0.027} _{+0.016}	26	16	0.3	12 700	16 200	1 300	1 650	14 000	21 000	NK18/16R	24	0.3	0.025
	26	20	0.3	16 100	22 000	1 640	2 250	14 000	21 000	NK18/20R	24	0.3	0.031
19 ^{+0.033} _{+0.020}	27	16	0.3	13 300	17 400	1 350	1 780	14 000	21 000	NK19/16R	25	0.3	0.026
	27	20	0.3	16 000	22 200	1 630	2 260	14 000	21 000	NK19/20R	25	0.3	0.032
20 ^{+0.033} _{+0.020}	28	13	0.3	10 300	12 800	1 050	1 310	13 000	20 000	RNA4902R	26	0.3	0.022
	28	16	0.3	13 200	17 500	1 340	1 790	13 000	20 000	NK20/16R	26	0.3	0.027
	28	18	0.3	14 100	19 100	1 440	1 950	13 000	20 000	RNA5902	26	0.3	0.033
	28	20	0.3	16 700	23 800	1 700	2 420	13 000	20 000	NK20/20R	26	0.3	0.034
	28	23	0.3	17 600	25 300	1 790	2 580	13 000	20 000	RNA6902R	26	0.3	0.040
21 ^{+0.033} _{+0.020}	29	16	0.3	13 700	18 700	1 400	1 910	13 000	19 000	NK21/16R	27	0.3	0.028
	29	20	0.3	18 300	27 100	1 860	2 760	13 000	19 000	NK21/20R	27	0.3	0.035
22 ^{+0.033} _{+0.020}	30	16	0.3	14 200	19 900	1 450	2 030	12 000	18 000	NK22/16R	28	0.3	0.034
	30	20	0.3	18 000	27 000	1 840	2 760	12 000	18 000	NK22/20R	28	0.3	0.037
	30	13	0.3	11 200	14 600	1 140	1 490	12 000	18 000	RNA4903R	28	0.3	0.022
	30	18	0.3	15 200	21 700	1 550	2 210	12 000	18 000	RNA5903	28	0.3	0.035
	30	23	0.3	18 200	27 200	1 850	2 770	12 000	18 000	RNA6903R	28	0.3	0.042
24 ^{+0.033} _{+0.020}	32	16	0.3	15 200	22 300	1 550	2 280	11 000	170 00	NK24/16R	30	0.3	0.032
	32	20	0.3	18 600	28 800	1 890	2 930	11 000	17 000	NK24/20R	30	0.3	0.040
25 ^{+0.033} _{+0.020}	33	16	0.3	15 100	22 400	1 540	2 280	11 000	16 000	NK25/16R	31	0.3	0.033
	33	20	0.3	19 200	30 500	1 960	3 100	11 000	16 000	NK25/20R	31	0.3	0.042
	37	17	0.3	21 300	25 500	2 170	2 600	11 000	16 000	RNA4904R	35	0.3	0.052
	37	23	0.3	28 400	37 000	2 900	3 750	11 000	16 000	RNA5904	35	0.3	0.084
	37	30	0.3	36 500	50 500	3 700	5 150	11 000	16 000	RNA6904R	35	0.3	0.100
26 ^{+0.033} _{+0.020}	34	16	0.3	15 600	23 600	1 590	2 410	10 000	15 000	NK26/16R	32	0.3	0.034
	34	20	0.3	19 100	30 500	1 940	3 100	10 000	15 000	NK26/20R	32	0.3	0.042
28 ^{+0.033} _{+0.020}	37	20	0.3	22 300	34 000	2 280	3 450	9 500	14 000	NK28/20R	35	0.3	0.052
	37	30	0.3	26 700	48 000	2 720	4 900	9 500	14 000	NK28/30R	35	0.3	0.082

Note 1) Allowable minimum chamfer dimension r_s .

Without Inner Ring

Type RNA49
Type RNA59
Type RNA69
Type NK

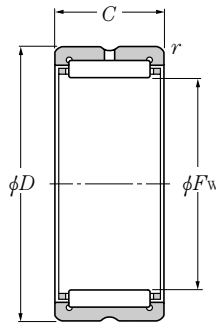

Type RNA49 · R
Type RNA59
Type RNA69 · R ($F_w \leq 35\text{mm}$)
Type NK · R

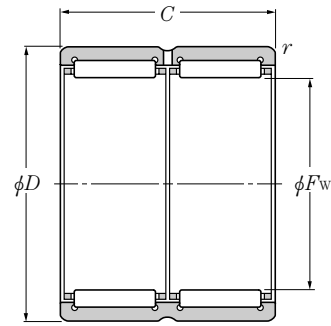

Type RNA69 · R ($F_w \geq 40\text{mm}$)

F_w 28~40mm

Boundary dimensions				Basic load ratings				Limiting speeds		Bearing numbers	Abutment dimensions		Mass kg (approx.)
mm				dynamic	static	dynamic	static	r/min			D_a	r_{as}	
F_w	D	C	$r_{s \min}^1)$	N		kgf		grease	oil	max	max		
28 ^{+0.033} _{+0.020}	39	17	0.3	23 200	29 300	2 360	2 990	9 500	14 000	RNA49/22R	37	0.3	0.050
	39	23	0.3	26 400	37 500	2 690	3 850	9 500	14 000	RNA59/22	37	0.3	0.092
	39	30	0.3	40 000	58 500	4 050	6 000	9 500	14 000	RNA69/22R	37	0.3	0.100
29 ^{+0.033} _{+0.020}	38	20	0.3	22 200	34 000	2 270	3 450	9 500	14 000	NK29/20R	36	0.3	0.054
	38	30	0.3	27 500	50 500	2 810	5 150	9 500	14 000	NK29/30R	36	0.3	0.084
30 ^{+0.033} _{+0.020}	40	20	0.3	22 100	34 000	2 260	3 500	8 500	13 000	NK30/20R	38	0.3	0.065
	40	30	0.3	33 000	57 000	3 350	5 800	8 500	13 000	NK30/30R	38	0.3	0.098
	42	17	0.3	24 000	31 500	2 450	3 200	8 500	13 000	RNA4905R	40	0.3	0.061
	42	23	0.3	30 500	43 000	3 150	4 350	8 500	13 000	RNA5905	40	0.3	0.101
	42	30	0.3	41 500	63 000	4 200	6 400	8 500	13 000	RNA6905R	40	0.3	0.112
32 ^{+0.041} _{+0.025}	42	20	0.3	23 500	37 500	2 400	3 850	8 500	13 000	NK32/20R	40	0.3	0.068
	42	30	0.3	34 000	60 500	3 450	6 150	8 500	13 000	NK32/30R	40	0.3	0.102
	45	17	0.3	24 800	33 500	2 530	3 400	8 500	13 000	RNA49/28R	43	0.3	0.073
	45	23	0.3	32 000	45 500	3 250	4 650	8 500	13 000	RNA59/28	43	0.3	0.108
	45	30	0.3	43 000	67 000	4 350	6 850	8 500	13 000	RNA69/28R	43	0.3	0.135
35 ^{+0.041} _{+0.025}	45	20	0.3	24 800	41 500	2 520	4 250	7 500	11 000	NK35/20R	43	0.3	0.074
	45	30	0.3	36 000	66 500	3 650	6 800	7 500	11 000	NK35/30R	43	0.3	0.112
	47	17	0.3	25 500	35 500	2 600	3 600	7 500	11 000	RNA4906R	45	0.3	0.069
	47	23	0.3	32 500	48 500	3 350	4 950	7 500	11 000	RNA5906	45	0.3	0.108
	47	30	0.3	42 500	67 500	4 300	6 900	7 500	11 000	RNA6906R	45	0.3	0.126
37 ^{+0.041} _{+0.025}	47	20	0.3	25 300	43 500	2 580	4 400	7 500	11 000	NK37/20R	45	0.3	0.077
	47	30	0.3	36 500	69 500	3 750	7 100	7 500	11 000	NK37/30R	45	0.3	0.107
38 ^{+0.041} _{+0.025}	48	20	0.3	25 900	45 000	2 640	4 600	7 500	11 000	NK38/20R	46	0.3	0.079
	48	30	0.3	37 500	73 000	3 850	7 400	7 500	11 000	NK38/30R	46	0.3	0.107
40 ^{+0.041} _{+0.025}	50	20	0.3	26 400	47 000	2 700	4 800	6 500	10 000	NK40/20R	48	0.3	0.083
	50	30	0.3	38 500	76 000	3 900	7 750	6 500	10 000	NK40/30R	48	0.3	0.125
	52	20	0.6	31 500	47 500	3 200	4 850	6 500	10 000	RNA49/32R	48	0.6	0.089
	52	27	0.6	38 000	61 000	3 850	6 250	6 500	10 000	RNA59/32	48	0.6	0.149
	52	36	0.6	47 500	82 000	4 850	8 350	6 500	10 000	RNA69/32R	48	0.6	0.162

Note 1) Allowable minimum chamfer dimension r .

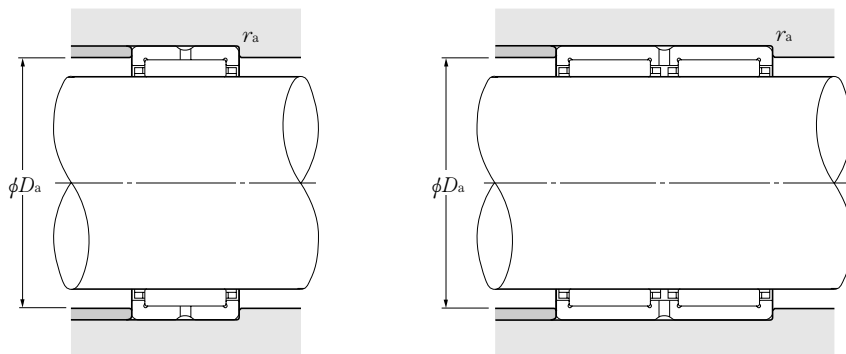

F_w 42~63mm

Boundary dimensions				Basic load ratings				Limiting speeds		Bearing numbers	Abutment dimensions		Mass kg (approx.)
mm				dynamic	static	dynamic	static	r/min			D_a	r_{as}	
F_w	D	C	r_s min ¹⁾	C_r	C_{or}	C_r	C_{or}	grease	oil		max	max	
42 ^{+0.041} _{+0.025}	52	20	0.3	26 900	49 000	2 750	5 000	6 500	9 500	NK42/20R	50	0.3	0.086
	52	30	0.3	39 000	79 000	4 000	8 050	6 500	9 500	NK42/30R	50	0.3	0.130
	55	20	0.6	32 000	50 000	3 300	5 100	6 500	9 500	RNA4907R	51	0.6	0.107
	55	27	0.6	39 000	64 500	3 950	6 550	6 500	9 500	RNA5907	51	0.6	0.176
	55	36	0.6	49 000	86 500	5 000	8 800	6 500	9 500	RNA6907R	51	0.6	0.193
43 ^{+0.041} _{+0.025}	53	20	0.3	27 500	51 000	2 810	5 200	6 500	9 500	NK43/20R	51	0.3	0.086
	53	30	0.3	40 000	82 000	4 100	8 400	6 500	9 500	NK43/30R	51	0.3	0.133
45 ^{+0.041} _{+0.025}	55	20	0.3	28 000	52 500	2 860	5 400	6 000	9 000	NK45/20R	53	0.3	0.092
	55	30	0.3	41 000	85 500	4 150	8 700	6 000	9 000	NK45/30R	53	0.3	0.139
47 ^{+0.041} _{+0.025}	57	20	0.3	28 800	55 500	2 940	5 650	5 500	8 500	NK47/20R	55	0.3	0.095
	57	30	0.3	42 500	91 500	4 350	9 350	5 500	8 500	NK47/30R	55	0.3	0.142
48 ^{+0.041} _{+0.025}	62	22	0.6	43 500	66 500	4 450	6 800	5 500	8 500	RNA4908R	58	0.6	0.140
	62	30	0.6	53 000	92 500	5 450	9 450	5 500	8 500	RNA5908	58	0.6	0.225
	62	40	0.6	67 000	116 000	6 850	11 800	5 500	8 500	RNA6908R	58	0.6	0.256
50 ^{+0.041} _{+0.025}	62	25	0.6	38 500	74 500	3 950	7 550	5 500	8 000	NK50/25R	58	0.6	0.158
	62	35	0.6	51 000	106 000	5 200	10 800	5 500	8 000	NK50/35R	58	0.6	0.221
52 ^{+0.049} _{+0.030}	68	22	0.6	46 000	73 000	4 700	7 450	5 000	7 500	RNA4909R	64	0.6	0.182
	68	30	0.6	56 000	101 000	5 700	10 300	5 000	7 500	RNA5909	64	0.6	0.232
	68	40	0.6	70 500	127 000	7 200	13 000	5 000	7 500	RNA6909R	64	0.6	0.273
55 ^{+0.049} _{+0.030}	68	25	0.6	41 000	82 000	4 150	8 400	5 000	7 500	NK55/25R	64	0.6	0.193
	68	35	0.6	54 000	118 000	5 500	12 000	5 000	7 500	NK55/35R	64	0.6	0.267
58 ^{+0.049} _{+0.030}	72	22	0.6	48 000	80 000	4 900	8 150	4 700	7 000	RNA4910R	68	0.6	0.163
	72	30	0.6	58 000	110 000	5 950	11 200	4 700	7 000	RNA5910	68	0.6	0.289
	72	40	0.6	74 000	139 000	7 500	14 200	4 700	7 000	RNA6910R	68	0.6	0.320
60 ^{+0.049} _{+0.030}	72	25	0.6	41 000	85 000	4 200	8 700	4 300	6 500	NK60/25R	68	0.6	0.185
	72	35	0.6	57 000	130 000	5 800	13 200	4 300	6 500	NK60/35R	68	0.6	0.258
63 ^{+0.049} _{+0.030}	80	25	1	58 500	99 500	6 000	10 100	4 300	6 500	RNA4911R	75	1	0.255
	80	34	1	76 500	140 000	7 800	14 300	4 300	6 500	RNA5911	75	1	0.367

Note 1) Allowable minimum chamfer dimension r_s .

Without Inner Ring

Type RNA49

Type RNA59

Type RNA69

Type NK

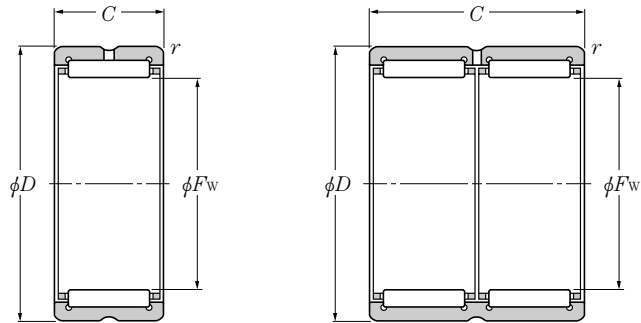

Type RNA48
Type RNA49 · R, Type RNA49
RNA59 type
Type NK · R, Type NK

Type RNA69 · R

F_w 63~85mm

Boundary dimensions				Basic load ratings				Limiting speeds		Bearing numbers	Abutment dimensions		Mass kg (approx.)
mm				dynamic	static	dynamic	static	r/min			mm		
F_w	D	C	r_s min ¹⁾	C_r	C_{or}	C_r	C_{or}	grease	oil		D_a max	r_{as} max	
63 ^{+0.049} / _{+0.030}	80	45	1	94 000	183 000	9 600	18 600	4 300	6 500	RNA6911R	75	1	0.470
65 ^{+0.049} / _{+0.030}	78	25	0.6	45 000	98 000	4 550	10 000	4 000	6 000	NK65/25R	74	0.6	0.221
	78	35	0.6	60 000	142 000	6 100	14 400	4 000	6 000	NK65/35R	74	0.6	0.310
68 ^{+0.049} / _{+0.030}	82	25	1	44 500	89 000	4 500	9 050	4 000	6 000	NK68/25R	77	0.6	0.241
	82	35	0.6	63 000	139 000	6 400	14 200	4 000	6 000	NK68/35R	78	0.6	0.338
	85	25	1	61 500	108 000	6 250	11 000	4 000	6 000	RNA4912R	80	1	0.275
	85	34	1	80 500	153 000	8 200	15 600	4 000	6 000	RNA5912	80	1	0.408
	85	45	1	95 500	191 000	9 750	19 400	4 000	6 000	RNA6912R	80	1	0.488
70 ^{+0.049} / _{+0.030}	85	25	0.6	45 000	91 500	4 600	9 350	3 700	5 500	NK70/25R	81	0.6	0.275
	85	35	0.6	64 000	144 000	6 550	14 700	3 700	5 500	NK70/35R	81	0.6	0.386
72 ^{+0.049} / _{+0.030}	90	25	1	62 500	112 000	6 350	11 400	3 700	5 500	RNA4913R	85	1	0.312
	90	34	1	84 000	165 000	8 600	16 800	3 700	5 500	RNA5913	85	1	0.462
	90	45	1	97 000	198 000	9 900	20 200	3 700	5 500	RNA6913R	85	1	0.520
73 ^{+0.049} / _{+0.030}	90	25	0.6	54 000	100 000	5 500	10 200	3 700	5 500	NK73/25R	86	0.6	0.302
	90	35	0.6	76 500	156 000	7 800	16 000	3 700	5 500	NK73/35R	86	0.6	0.428
75 ^{+0.049} / _{+0.030}	92	25	0.6	55 000	104 000	5 600	10 600	3 700	5 500	NK75/25R	88	0.6	0.315
	92	35	0.6	78 000	162 000	7 950	16 500	3 700	5 500	NK75/35R	88	0.6	0.492
80 ^{+0.049} / _{+0.030}	95	25	1	57 000	119 000	5 800	12 200	3 300	5 000	NK80/25R	90	1	0.301
	95	35	1	79 500	184 000	8 150	18 700	3 300	5 000	NK80/35R	90	1	0.425
	100	30	1	85 500	156 000	8 750	15 900	3 300	5 000	RNA4914R	95	1	0.460
	100	40	1	103 000	187 000	10 500	19 100	3 300	5 000	RNA5914	95	1	0.706
	100	54	1	130 000	267 000	13 300	27 200	3 300	5 000	RNA6914R	95	1	0.857
85 ^{+0.058} / _{+0.036}	105	25	1	70 500	123 000	7 200	12 600	3 100	4 700	NK85/25R	100	1	0.404
	105	30	1	87 000	162 000	8 900	16 500	3 100	4 700	RNA4915R	100	1	0.489
	105	35	1	100 000	193 000	10 200	19 700	3 100	4 700	NK85/35R	100	1	0.517
	105	40	1	109 000	205 000	11 100	20 900	3 100	4 700	RNA5915	100	1	0.745
	105	54	1	132 000	277 000	13 500	28 300	3 100	4 700	RNA6915R	100	1	0.935

Note 1) Allowable minimum chamfer dimension r .

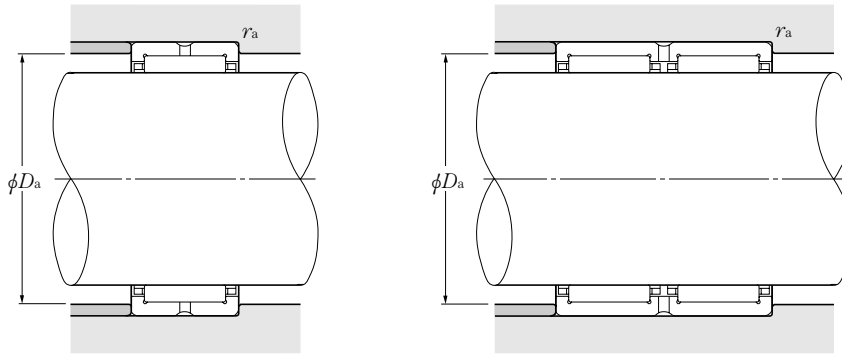

F_w 90~130mm

Boundary dimensions				Basic load ratings				Limiting speeds		Bearing numbers	Abutment and fillet dimensions		Mass kg (approx.)
mm				dynamic	static	dynamic	static	r/min			D_a	r_{as}	
F_w	D	B_e	$r_{s \min}^{1)}$	C_r	C_{or}	C_r	C_{or}	grease	oil		max	max	
90 ^{+0.058 +0.036}	110	25	1	71 500	128 000	7 300	13 100	2 900	4 400	NK90/25R	105	1	0.426
	110	30	1	90 500	174 000	9 250	17 700	2 900	4 400	RNA4916R	105	1	0.516
	110	35	1	104 000	208 000	10 600	21 200	2 900	4 400	NK90/35R	105	1	0.604
	110	40	1	115 000	223 000	11 700	22 700	2 900	4 400	RNA5916	105	1	0.787
	110	54	1	137 000	298 000	14 000	30 500	2 900	4 400	RNA6916R	105	1	0.987
95 ^{+0.058 +0.036}	115	26	1	74 500	137 000	7 600	14 000	2 800	4 200	NK95/26R	110	1	0.364
	115	36	1	108 000	223 000	11 100	22 700	2 800	4 200	NK95/36R	110	1	0.652
100 ^{+0.058 +0.036}	120	26	1	73 500	137 000	7 500	14 000	2 700	4 000	NK100/26R	115	1	0.487
	120	35	1.1	112 000	237 000	11 500	24 200	2 700	4 000	RNA4917R	113.5	1	0.657
	120	36	1	107 000	223 000	11 000	22 800	2 700	4 000	NK100/36R	115	1	0.679
	120	46	1.1	137 000	290 000	14 000	29 600	2 700	4 000	RNA5917	113.5	1	1.00
	120	63	1.1	169 000	400 000	17 300	41 000	2 700	4 000	RNA6917R	113.5	1	1.20
105 ^{+0.058 +0.036}	125	26	1	76 500	147 000	7 800	14 900	2 500	3 800	NK105/26R	120	1	0.506
	125	35	1.1	116 000	252 000	11 900	25 700	2 500	3 800	RNA4918R	118.5	1	0.697
	125	36	1	111 000	238 000	11 400	24 300	2 500	3 800	NK105/36R	120	1	0.713
	125	46	1.1	143 000	310 000	14 600	32 000	2 500	3 800	RNA5918	118.5	1	1.04
	125	63	1.1	175 000	425 000	17 900	43 500	2 500	3 800	RNA6918R	118.5	1	1.33
110 ^{+0.058 +0.036}	130	30	1.1	97 500	204 000	9 950	20 800	2 400	3 600	NK110/30R	123.5	1	0.612
	130	35	1.1	118 000	260 000	12 000	26 500	2 400	3 600	RNA4919R	123.5	1	0.719
	130	40	1.1	129 000	292 000	13 100	29 700	2 400	3 600	NK110/40R	123.5	1	0.830
	130	46	1.1	149 000	335 000	15 200	34 000	2 400	3 600	RNA5919	123.5	1	1.13
	130	63	1.1	177 000	440 000	18 100	45 000	2 400	3 600	RNA6919R	123.5	1	1.46
115 ^{+0.058 +0.036}	140	40	1.1	127 000	260 000	12 900	26 500	2 300	3 500	RNA4920	133.5	1	1.15
	140	54	1.1	182 000	395 000	18 600	40 500	2 300	3 500	RNA5920	133.5	1	1.76
120 ^{+0.058 +0.036}	140	30	1	93 500	210 000	9 550	21 400	2 200	3 300	RNA4822	135	1	0.670
	140	40	1.1	113 000	268 000	11 500	27 300	2 200	3 300	NK120/40	133.5	1	0.910
125 ^{+0.068 +0.043}	150	40	1.1	131 000	279 000	13 300	28 400	2 100	3 200	RNA4922	143.5	1	1.24
	150	54	1.1	193 000	440 000	19 700	45 000	2 100	3 200	RNA5922	143.5	1	1.89
130 ^{+0.068 +0.043}	150	30	1	99 500	233 000	10 100	23 800	2 100	3 100	RNA4824	145	1	0.730

Note 1) Allowable minimum chamfer dimension r .

Without Inner Ring

Type RNA48

Type RNA49

Type RNA59

Type NK

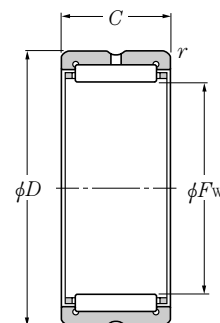

F_w 130~220mm

Boundary dimensions				Basic load ratings				Limiting speeds		Bearing numbers	Abutment dimensions		Mass kg (approx.)
mm				dynamic	static	dynamic	static	r/min			D_a	r_{as}	
F_w	D	C	$r_{s \min}^1)$	N		kgf		grease	oil	max	max		
130 ^{+0.068} / _{+0.043}	150	40	1.1	116 000	283 000	11 800	28 800	2 100	3 100	NK130/40	143.5	1	0.98
135 ^{+0.068} / _{+0.043}	165	45	1.1	180 000	380 000	18 300	38 500	2 000	3 000	RNA4924	158.5	1	1.86
	165	60	1.1	245 000	525 000	25 000	53 500	2 000	3 000	RNA5924	158.5	1	2.67
145 ^{+0.068} / _{+0.043}	165	35	1.1	118 000	305 000	12 100	31 000	1 900	2 800	RNA4826	158.5	1	0.95
	170	32	1.5	111 000	238 000	11 300	24 300	1 900	2 800	NK145/32	162.5	1.5	1.12
	170	42	1.5	153 000	360 000	15 600	36 500	1 900	2 800	NK145/42	162.5	1.5	1.49
150 ^{+0.068} / _{+0.043}	180	50	1.5	202 000	455 000	20 600	46 500	1 800	2 700	RNA4926	172	1.5	2.21
	180	67	1.5	294 000	685 000	30 000	70 000	1 800	2 700	RNA5926	172	1.5	3.21
155 ^{+0.068} / _{+0.043}	175	35	1.1	121 000	315 000	12 300	32 500	1 700	2 600	RNA4828	168.5	1	1.02
	180	32	1.5	114 000	252 000	11 600	25 700	1 700	2 600	NK155/32	172	1.5	1.20
	180	42	1.5	156 000	380 000	16 000	38 500	1 700	2 600	NK155/42	172	1.5	1.59
160 ^{+0.068} / _{+0.043}	190	50	1.5	209 000	485 000	21 300	49 500	1 700	2 500	RNA4928	182	1.5	2.35
	190	67	1.5	310 000	755 000	31 500	77 000	1 700	2 500	RNA5928	182	1.5	3.48
165 ^{+0.068} / _{+0.043}	190	32	1.5	117 000	265 000	11 900	27 000	1 600	2 400	NK165/32	182	1.5	1.42
	190	40	1.1	152 000	390 000	15 500	40 000	1 600	2 400	RNA4830	183.5	1	1.60
	190	42	1.5	160 000	400 000	16 300	40 500	1 600	2 400	NK165/42	182	1.5	1.66
170 ^{+0.068} / _{+0.043}	210	60	2	261 000	610 000	26 600	62 500	1 600	2 400	RNA4930	201	2	2.98
175 ^{+0.068} / _{+0.043}	200	40	1.1	160 000	425 000	16 300	43 500	1 500	2 300	RNA4832	193.5	1	1.70
180 ^{+0.068} / _{+0.043}	220	60	2	270 000	650 000	27 600	66 500	1 500	2 200	RNA4932	211	2	3.10
185 ^{+0.079} / _{+0.050}	215	45	1.1	185 000	495 000	18 800	50 500	1 500	2 200	RNA4834	208.5	1	2.54
190 ^{+0.079} / _{+0.050}	230	60	2	279 000	690 000	28 500	70 500	1 400	2 100	RNA4934	221	2	3.22
195 ^{+0.079} / _{+0.050}	225	45	1.1	195 000	540 000	19 800	55 000	1 400	2 100	RNA4836	218.5	1	2.68
205 ^{+0.079} / _{+0.050}	250	69	2	375 000	890 000	38 500	90 500	1 300	2 000	RNA4936	241	2	4.48
210 ^{+0.079} / _{+0.050}	240	50	1.5	227 000	680 000	23 200	69 000	1 300	1 900	RNA4838	232	1.5	3.21
215 ^{+0.079} / _{+0.050}	260	69	2	390 000	945 000	40 000	96 500	1 300	1 900	RNA4938	251	2	4.53
220 ^{+0.079} / _{+0.050}	250	50	1.5	231 000	705 000	23 600	71 500	1 200	1 800	RNA4840	242	1.5	3.35

Note 1) Allowable minimum chamfer dimension r .

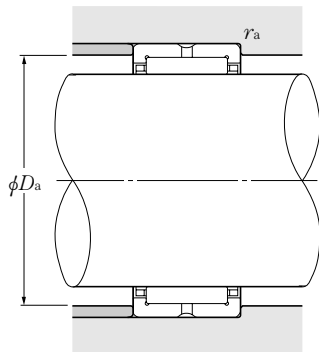

F_w 225~490mm

Boundary dimensions				Basic load ratings				Limiting speeds		Bearing numbers	Abutment and fillet dimensions		Mass kg (approx.)
mm				dynamic	static	dynamic	static	r/min			D_a	r_{as}	
F_w	D	B_e	$r_{s \min}^1$	C_r	C_{or}	C_r	C_{or}	grease	oil		max	max	
225 ^{+0.079} / _{+0.050}	280	80	2.1	505 000	1 180 000	51 500	120 000	1 200	1 800	RNA4940	269	2	7.20
240 ^{+0.079} / _{+0.050}	270	50	1.5	242 000	770 000	24 700	78 500	1 100	1 700	RNA4844	262	1.5	3.62
245 ^{+0.079} / _{+0.050}	300	80	2.1	525 000	1 270 000	53 500	129 000	1 100	1 600	RNA4944	289	2	7.81
265 ^{+0.088} / _{+0.056}	300	60	2	360 000	1 080 000	37 000	110 000	1 000	1 500	RNA4848	291	2	5.40
	320	80	2.1	540 000	1 350 000	55 000	138 000	1 000	1 500	RNA4948	309	2	8.40
285 ^{+0.088} / _{+0.056}	320	60	2	375 000	1 160 000	38 000	119 000	950	1 400	RNA4852	311	2	5.80
290 ^{+0.088} / _{+0.056}	360	100	2.1	805 000	1 900 000	82 000	193 000	950	1 400	RNA4952	349	2	15.90
305 ^{+0.088} / _{+0.056}	350	69	2	455 000	1 300 000	46 500	133 000	850	1 300	RNA4856	341	2	9.30
310 ^{+0.088} / _{+0.056}	380	100	2.1	835 000	2 030 000	85 000	207 000	850	1 300	RNA4956	369	2	16.70
330 ^{+0.098} / _{+0.062}	380	80	2.1	625 000	1 770 000	64 000	180 000	800	1 200	RNA4860	369	2	12.70
340 ^{+0.098} / _{+0.062}	420	118	3	1 080 000	2 640 000	110 000	269 000	800	1 200	RNA4960	407	2.5	24.00
350 ^{+0.098} / _{+0.062}	400	80	2.1	640 000	1 850 000	65 500	189 000	750	1 100	RNA4864	389	2	13.40
360 ^{+0.098} / _{+0.062}	440	118	3	1 120 000	2 820 000	114 000	288 000	750	1 100	RNA4964	427	2.5	25.20
370 ^{+0.098} / _{+0.062}	420	80	2.1	655 000	1 940 000	66 500	197 000	750	1 100	RNA4868	409	2	14.00
380 ^{+0.098} / _{+0.062}	460	118	3	1 160 000	3 000 000	118 000	305 000	750	1 100	RNA4968	447	2.5	26.50
390 ^{+0.098} / _{+0.062}	440	80	2.1	665 000	2 020 000	68 000	206 000	650	1 000	RNA4872	429	2	14.80
400 ^{+0.108} / _{+0.068}	480	118	3	1 200 000	3 200 000	122 000	325 000	650	1 000	RNA4972	467	2.5	28.20
415 ^{+0.108} / _{+0.068}	480	100	2.1	1 000 000	2 840 000	102 000	289 000	650	950	RNA4876	469	2	26.00
430 ^{+0.108} / _{+0.068}	520	140	4	1 400 000	3 750 000	143 000	385 000	650	950	RNA4976	504	3	38.60
450 ^{+0.108} / _{+0.068}	540	140	4	1 450 000	4 000 000	148 000	410 000	600	900	RNA4980	524	3	40.10
470 ^{+0.108} / _{+0.068}	560	140	4	1 500 000	4 250 000	153 000	430 000	550	850	RNA4984	544	3	51.60
490 ^{+0.108} / _{+0.068}	600	160	4	1 750 000	4 600 000	179 000	470 000	550	800	RNA4988	584	3	66.90

Note 1) Allowable minimum chamfer dimension r .

With inner ring

Type NA49
Type NA59
Type NA69
Type NK+IR

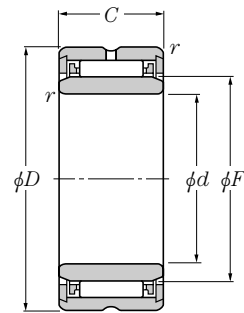

Type NA49 ($d \leq 9\text{mm}$)

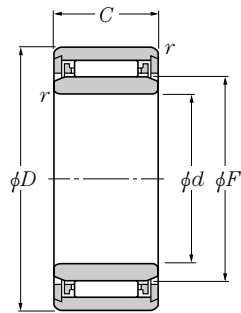

Type NK+IR ($d \leq 9\text{mm}$)

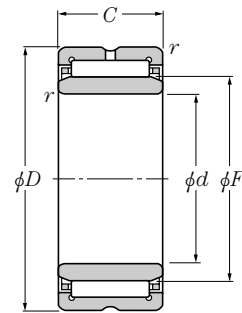

Type NA49·R ($d \geq 10\text{mm}$)
Type NA59
Type NA69·R
Type NK+IR ($d \geq 10\text{mm}$)

d 5~17mm

Boundary dimensions						Basic load ratings				Limiting speeds		Bearing numbers
mm						dynamic	static	dynamic	static	r/min		
d	D	C	$r_{s\min}^{1)}$	F	$s^{2)}$	C_r	C_{or}	C_r	C_{or}	grease	oil	
5	13	10	0.15	7	—	2 670	2 350	272	239	23 000	34 000	NA495T2
	15	12	0.3	8	1.5	4 000	4 100	410	420	21 000	32 000	NK8/12T2+IR5×8×12
	15	16	0.3	8	2	4 850	5 200	495	535	21 000	32 000	NK8/16T2+IR5×8×16
6	15	10	0.15	8	—	3 150	3 000	320	305	21 000	32 000	NA496
	16	12	0.3	9	1.5	4 550	5 000	465	510	20 000	30 000	NK9/12T2+IR6×9×12
	16	16	0.3	9	2	5 500	6 400	560	650	20 000	30 000	NK9/16T2+IR6×9×16
7	17	10	0.15	9	—	3 600	3 650	365	375	20 000	30 000	NA497
	17	12	0.3	10	1.5	4 550	5 100	460	520	19 000	28 000	NK10/12T2+IR7×10×12
	17	16	0.3	10	2	5 450	6 450	555	660	19 000	28 000	NK10/16+IR7×10×16
8	19	11	0.15	10	—	4 300	3 950	435	405	19 000	28 000	NA498
9	19	12	0.3	12	1.5	5 000	6 100	510	620	17 000	26 000	NK12/12+IR9×12×12
	19	16	0.3	12	2	6 000	7 700	615	785	17 000	26 000	NK12/16+IR9×12×16
	20	11	0.3	12	—	4 850	4 900	495	500	17 000	26 000	NA499
10	22	13	0.3	14	0.5	8 600	9 200	875	935	16 000	24 000	NA4900R
	22	16	0.3	14	0.5	10 300	11 500	1 050	1 170	16 000	24 000	NK14/16R+IR10×14×16
	22	20	0.3	14	0.5	13 000	15 600	1 330	1 590	16 000	24 000	NK14/20R+IR10×14×20
12	24	13	0.3	16	0.5	9 550	10 900	975	1 110	15 000	23 000	NA4901R
	24	16	0.3	16	0.5	12 200	14 900	1 240	1 520	15 000	23 000	NK16/16R+IR12×16×16
	24	20	0.3	16	0.5	14 600	18 800	1 490	1 920	15 000	23 000	NK16/20R+IR12×16×20
	24	22	0.3	16	1	15 400	20 000	1 570	2 040	15 000	23 000	NA6901R
15	27	16	0.3	19	0.5	13 300	17 400	1 350	1 780	14 000	21 000	NK19/16R+IR15×19×16
	27	20	0.3	19	0.5	16 000	22 200	1 630	2 260	14 000	21 000	NK19/20R+IR15×19×20
	28	13	0.3	20	0.5	10 300	12 800	1 050	1 310	13 000	20 000	NA4902R
	28	18	0.3	20	0.5	14 100	19 100	1 440	1 950	13 000	20 000	NA5902
17	28	23	0.3	20	1	17 600	25 300	1 790	2 580	13 000	20 000	NA6902R
	29	16	0.3	21	0.5	13 700	18 700	1 400	1 910	13 000	19 000	NK21/16R+IR17×21×16
	29	20	0.3	21	0.5	18 300	27 100	1 860	2 760	13 000	19 000	NK21/20R+IR17×21×20
	30	13	0.3	22	0.5	11 200	14 600	1 140	1 490	12 000	18 000	NA4903R
	30	18	0.3	22	0.5	15 200	21 700	1 550	2 210	12 000	18 000	NA5903

Note 1) Allowable minimum chamfer dimension. 2) Allowable axial stroking value of inner ring against outer ring.
Remarks: Nominal code number of inner ring (IR) comprises the codes of IR bore diameter×outer diameter×width.

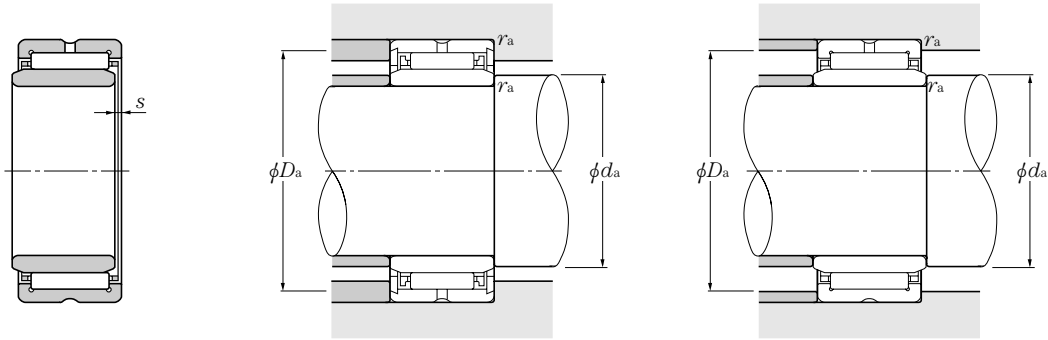

Abutment dimensions			Mass
d_a	mm		kg
min	D_a max	r_{as} max	(approx.)
6.2	8.5	0.15	0.007
7	9.5	0.3	0.012
7	9.5	0.3	0.016
8	9.5	0.15	0.009
8	10.5	0.3	0.013
8	10.5	0.3	0.017
9	10.5	0.15	0.010
9	11.5	0.3	0.014
9	11.5	0.3	0.018
10	12	0.15	0.016
11	13.5	0.3	0.018
11	13.5	0.3	0.022
11	14	0.3	0.017
12	20	0.3	0.024
12	20	0.3	0.030
12	20	0.3	0.038
14	22	0.3	0.026
14	22	0.3	0.033
14	22	0.3	0.042
14	22	0.3	0.046
17	25	0.3	0.039
17	25	0.3	0.045
17	26	0.3	0.036
17	26	0.3	0.052
17	26	0.3	0.064
19	27	0.3	0.042
19	27	0.3	0.053
19	28	0.3	0.037
19	28	0.3	0.056

With inner ring

Type NA49
 Type NA59
 Type NA69
 Type NK+IR

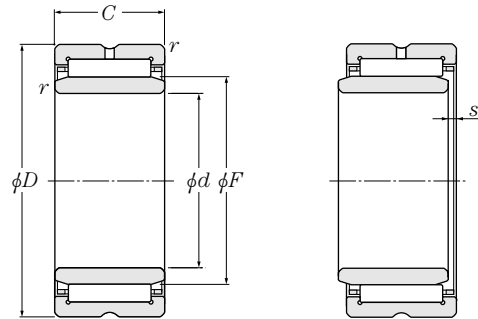

Type NA49 · R
 Type NA59
 Type NA69 · R ($d \leq 30\text{mm}$)
 Type NK+IR

d 17~32mm

Boundary dimensions						Basic load ratings				Limiting speeds		Bearing numbers
mm						dynamic	static	dynamic	static	r/min		
d	D	C	$r_{s \min}^{1)}$	F	$s^{2)}$	N		kgf		grease	oil	
						C_r	C_{or}	C_r	C_{or}			
17	30	23	0.3	22	1	18 200	27 200	1 850	2 770	12 000	18 000	NA6903R
	32	16	0.3	24	0.5	15 200	22 300	1 550	2 280	11 000	17 000	NK24/16R+IR20×24×16
20	32	20	0.3	24	0.5	18 600	28 800	1 890	2 930	11 000	17 000	NK24/20R+IR20×24×20
	37	17	0.3	25	0.8	21 300	25 500	2 170	2 600	11 000	16 000	NA4904R
	37	23	0.3	25	0.8	28 400	37 000	2 900	3 750	11 000	16 000	NA5904
	37	30	0.3	25	1	36 500	50 500	3 700	5 150	11 000	16 000	NA6904R
22	34	16	0.3	26	0.5	15 600	23 600	1 590	2 410	10 000	15 000	NK26/16R+IR22×26×16
	34	20	0.3	26	0.5	19 100	30 500	1 940	3 100	10 000	15 000	NK26/20R+IR22×26×20
	39	17	0.3	28	0.8	23 200	29 300	2 360	2 990	9 500	14 000	NA49/22R
	39	23	0.3	28	0.8	26 400	37 500	2 690	3 850	9 500	14 000	NA59/22
	39	30	0.3	28	0.5	40 000	58 500	4 050	6 000	9 500	14 000	NA69/22R
25	38	20	0.3	29	1	22 200	34 000	2 270	3 450	9 500	14 000	NK29/20R+IR25×29×20
	38	30	0.3	29	1.5	27 500	50 500	2 810	5 150	9 500	14 000	NK29/30R+IR25×29×30
	42	17	0.3	30	0.8	24 000	31 500	2 450	3 200	8 500	13 000	NA4905R
	42	23	0.3	30	0.8	30 500	43 000	3 150	4 350	8 500	13 000	NA5905
	42	30	0.3	30	1	41 500	63 000	4 200	6 400	8 500	13 000	NA6905R
28	42	20	0.3	32	1	23 500	37 500	2 400	3 850	8 500	13 000	NK32/20R+IR28×32×20
	42	30	0.3	32	1.5	34 000	60 500	3 450	6 150	8 500	13 000	NK32/30R+IR28×32×30
	45	17	0.3	32	0.8	24 800	33 500	2 530	3 400	8 500	13 000	NA49/28R
	45	23	0.3	32	0.8	32 000	45 500	3 250	4 650	8 500	13 000	NA59/28
	45	30	0.3	32	1	43 000	67 000	4 350	6 850	8 500	13 000	NA69/28R
30	45	20	0.3	35	0.5	24 800	41 500	2 520	4 250	7 500	11 000	NK35/20R+IR30×35×20
	45	30	0.3	35	1	36 000	66 500	3 650	6 800	7 500	11 000	NK35/30R+IR30×35×30
	47	17	0.3	35	0.8	25 500	35 500	2 600	3 600	7 500	11 000	NA4906R
	47	23	0.3	35	0.8	32 500	48 500	3 350	4 950	7 500	11 000	NA5906
	47	30	0.3	35	1	42 500	67 500	4 300	6 900	7 500	11 000	NA6906R
32	47	20	0.3	37	0.5	25 300	43 500	2 580	4 400	7 500	11 000	NK37/20R+IR32×37×20
	47	30	0.3	37	1	36 500	69 500	3 750	7 100	7 500	11 000	NK37/30R+IR32×37×30
	52	20	0.6	40	0.8	31 500	47 500	3 200	4 850	6 500	10 000	NA49/32R

Note 1) Allowable minimum chamfer dimension r . 2) Allowable axial stroking value of inner ring against outer ring.
 Remarks: Nominal code number of inner ring (IR) comprises the codes of IR bore diameter×outer diameter×width.

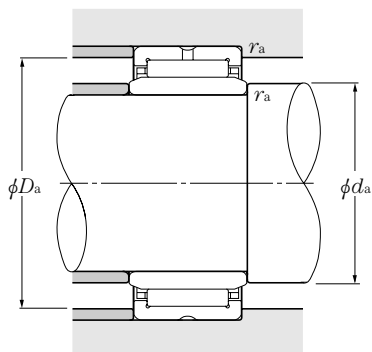

Abutment dimensions			Mass
d_a	mm D_a		kg
min	max	r_{as} max	(approx.)
19	28	0.3	0.069
22	30	0.3	0.049
22	30	0.3	0.061
22	35	0.3	0.074
22	35	0.3	0.115
22	35	0.3	0.141
24	32	0.3	0.046
24	32	0.3	0.064
24	37	0.3	0.080
24	37	0.3	0.134
24	37	0.3	0.154
27	36	0.3	0.079
27	36	0.3	0.123
27	40	0.3	0.088
27	40	0.3	0.139
27	40	0.3	0.162
30	40	0.3	0.096
30	40	0.3	0.146
30	43	0.3	0.098
30	43	0.3	0.142
30	43	0.3	0.179
32	43	0.3	0.112
32	43	0.3	0.171
32	45	0.3	0.101
32	45	0.3	0.152
32	45	0.3	0.185
34	45	0.3	0.117
34	45	0.3	0.170
36	48	0.6	0.157

With inner ring

Type NA49
Type NA59
Type NA69
Type NK+IR

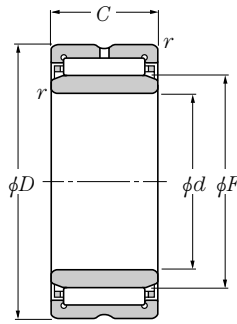

Type NA49 · R
Type NA59
Type NK · R + IR

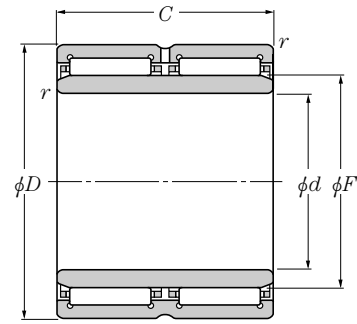

Type NA69 · R

d 32~55mm

Boundary dimensions						Basic load ratings				Limiting speeds		Bearing numbers
mm						dynamic	static	dynamic	static	r/min		
d	D	C	r _{s min} ¹⁾	F	s ²⁾	N		kgf		grease	oil	
						C _r	C _{0r}	C _r	C _{0r}			
32	52	27	0.6	40	0.8	38 000	61 000	3 850	6 250	6 500	10 000	NA59/32
	52	36	0.6	40	0.5	47 500	82 000	4 850	4 350	6 500	10 000	NA69/32R
35	50	20	0.3	40	0.5	26 400	47 000	2 700	4 800	6 500	10 000	NK40/20R + IR35 × 40 × 20
	50	30	0.3	40	1	38 500	76 000	3 900	7 750	6 500	10 000	NK40/30R + IR35 × 40 × 30
	55	20	0.6	42	0.8	32 000	50 000	3 300	5 100	6 500	9 500	NA4907R
	55	27	0.6	42	0.8	39 000	64 500	3 950	6 550	6 500	9 500	NA5907
	55	36	0.6	42	0.5	49 000	86 500	5 000	8 800	6 500	9 500	NA6907R
38	53	20	0.3	43	0.5	27 500	51 000	2 810	5 200	6 500	9 500	NK43/20R + IR38 × 43 × 20
	53	30	0.3	43	1	40 000	82 000	4 100	8 400	6 500	9 500	NK43/30R + IR38 × 43 × 30
40	55	20	0.3	45	0.5	28 000	52 500	2 860	5 400	6 000	9 000	NK45/20R + IR40 × 45 × 20
	55	30	0.3	45	1	41 000	85 500	4 150	8 700	6 000	9 000	NK45/30R + IR40 × 45 × 30
	62	22	0.6	48	1	43 500	66 500	4 450	6 800	5 500	8 500	NA4908R
	62	30	0.6	48	1	53 000	92 500	5 450	9 450	5 500	8 500	NA5908
	62	40	0.6	48	0.5	67 000	116 000	6 850	11 800	5 500	8 500	NA6908R
42	57	20	0.3	47	0.5	28 800	55 500	2 940	5 650	5 500	8 500	NK47/20R + IR42 × 47 × 20
	57	30	0.3	47	1	42 500	91 500	4 350	9 350	5 500	8 500	NK47/30R + IR42 × 47 × 30
45	62	25	0.6	50	1.5	38 500	74 500	3 950	7 550	5 500	8 000	NK50/25R + IR45 × 50 × 25
	62	35	0.6	50	2	51 000	106 000	5 200	10 800	5 500	8 000	NK50/35R + IR45 × 50 × 35
	68	22	0.6	52	1	46 000	73 000	4 700	7 450	5 000	7 500	NA4909R
	68	30	0.6	52	1	56 000	101 000	5 700	10 300	5 000	7 500	NA5909
	68	40	0.6	52	0.5	70 500	127 000	7 200	13 000	5 000	7 500	NA6909R
50	68	25	0.6	55	1.5	41 000	82 000	4 150	8 400	5 000	7 500	NK55/25R + IR50 × 55 × 25
	68	35	0.6	55	2	54 000	118 000	5 500	12 000	5 000	7 500	NK55/35R + IR50 × 55 × 35
	72	22	0.6	58	1	48 000	80 000	4 900	8 150	4 700	7 000	NA4910R
	72	30	0.6	58	1	58 000	110 000	5 950	11 200	4 700	7 000	NA5910
	72	40	0.6	58	0.5	74 000	139 000	7 500	14 200	4 700	7 000	NA6910R
55	72	25	0.6	60	1.5	41 000	85 000	4 200	8 700	4 300	6 500	NK60/25R + IR55 × 60 × 25
	72	35	0.6	60	2	57 000	130 000	5 800	13 200	4 300	6 500	NK60/35R + IR55 × 60 × 35
	80	25	1	63	1.5	58 500	99 500	6 000	10 100	4 300	6 500	NA4911R

Note 1) Allowable minimum chamfer dimension r . 2) Allowable axial stroking value of inner ring against outer ring.
Remarks: Nominal code number of inner ring (IR) comprises the codes of IR bore diameter × outer diameter × width.

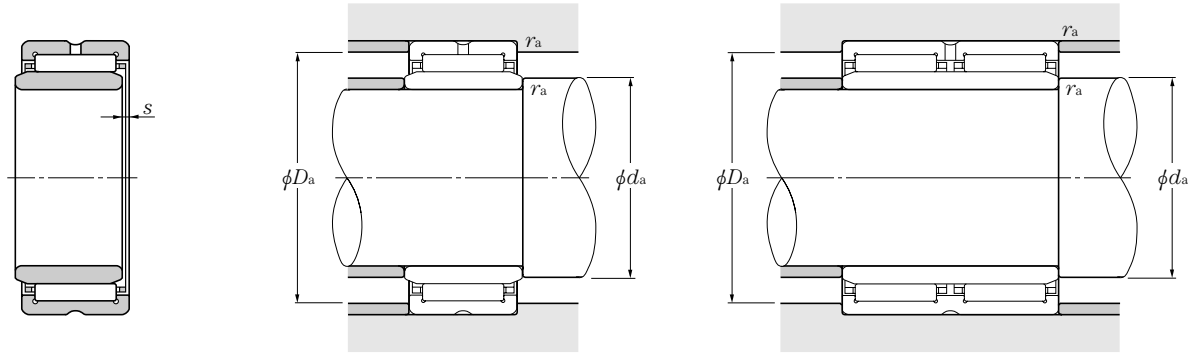

Abutment dimensions			Mass
d_a	mm		kg
min	D_a	r_{as}	(approx.)
	max	max	
36	48	0.6	0.241
36	48	0.6	0.286
37	48	0.3	0.130
37	48	0.3	0.193
39	51	0.6	0.171
39	51	0.6	0.256
39	51	0.6	0.310
40	51	0.3	0.134
40	51	0.3	0.207
42	53	0.3	0.143
42	53	0.3	0.216
44	58	0.6	0.232
44	58	0.6	0.348
44	58	0.6	0.426
44	55	0.3	0.148
44	55	0.3	0.222
48	58	0.6	0.229
48	58	0.6	0.322
49	64	0.6	0.270
49	64	0.6	0.396
49	64	0.6	0.437
53	64	0.6	0.271
53	64	0.6	0.379
54	68	0.6	0.276
54	68	0.6	0.498
54	68	0.6	0.529
58	68	0.6	0.271
58	68	0.6	0.379
60	75	1	0.396

With inner ring

Type NA49
Type NA59
Type NA69
Type NK+IR

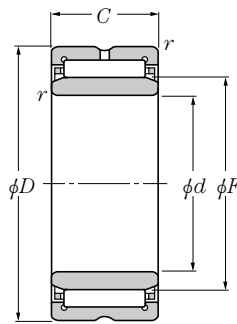

Type NA49 · · R
Type NA59
Type NK · · R + IR

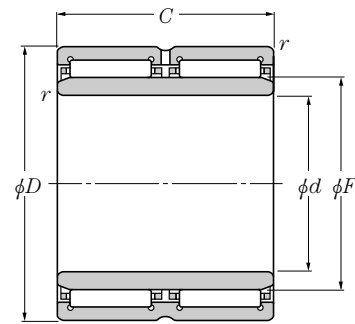

Type NA69 · · R

d 55~85mm

Boundary dimensions						Basic load ratings				Limiting speeds		Bearing numbers
mm						dynamic	static	dynamic	static	r/min		
d	D	C	r _{s min} ¹⁾	F	s ²⁾	N		kgf		grease	oil	
						C _r	C _{0r}	C _r	C _{0r}			
55	80	34	1	63	1.5	76 500	140 000	7 800	14 300	4 300	6 500	NA5911
	80	45	1	63	1.5	94 000	183 000	9 600	18 600	4 300	6 500	NA6911R
60	82	25	1	68	1	44 500	89 000	4 500	9 050	4 000	6 000	NK68/25R + IR60 × 68 × 25
	82	35	0.6	68	1	63 000	139 000	6 400	14 200	4 000	6 000	NK68/35R + IR60 × 68 × 35
	85	25	1	68	1.5	61 500	108 000	6 250	11 000	4 000	6 000	NA4912R
	85	34	1	68	1.5	80 500	153 000	8 200	15 600	4 000	6 000	NA5912
	85	45	1	68	1.5	95 500	191 000	9 750	19 400	4 000	6 000	NA6912R
65	90	25	0.6	73	1	54 000	100 000	5 500	10 200	3 700	5 500	NK73/25R + IR65 × 73 × 25
	90	25	1	72	1.5	62 500	112 000	6 350	11 400	3 700	5 500	NA4913R
	90	34	1	72	1.5	84 000	165 000	8 600	16 800	3 700	5 500	NA5913
	90	35	0.6	73	1	76 500	156 000	7 800	16 000	3 700	5 500	NK73/35R + IR65 × 73 × 35
	90	45	1	72	1.5	97 000	198 000	9 900	20 200	3 700	5 500	NA6913R
70	95	25	1	80	0.8	57 000	119 000	5 800	12 200	3 300	5 000	NK80/25R + IR70 × 80 × 25
	95	35	1	80	0.8	79 500	184 000	8 150	18 700	3 300	5 000	NK80/35R + IR70 × 80 × 35
	100	30	1	80	1.5	85 500	156 000	8 750	15 900	3 300	5 000	NA4914R
	100	40	1	80	1.5	103 000	187 000	10 500	19 100	3 300	5 000	NA5914
	100	54	1	80	1	130 000	267 000	13 300	27 200	3 300	5 000	NA6914R
75	105	25	1	85	1	70 500	123 000	7 200	12 600	3 100	4 700	NK85/25R + IR75 × 85 × 25
	105	30	1	85	1.5	87 000	162 000	8 900	16 500	3 100	4 700	NA4915R
	105	35	1	85	1	100 000	193 000	10 200	19 700	3 100	4 700	NK85/35R + IR75 × 85 × 35
	105	40	1	85	1.5	109 000	205 000	11 100	20 900	3 100	4 700	NA5915
	105	54	1	85	1	132 000	277 000	13 500	28 300	3 100	4 700	NA6915R
80	110	25	1	90	1	71 500	128 000	7 300	13 100	2 900	4 400	NK90/25R + IR80 × 90 × 25
	110	30	1	90	1.5	90 500	174 000	9 250	17 700	2 900	4 400	NA4916R
	110	35	1	90	1	104 000	208 000	10 600	21 200	2 900	4 400	NK90/35R + IR80 × 90 × 35
	110	40	1	90	1.5	115 000	223 000	11 700	22 700	2 900	4 400	NA5916
	110	54	1	90	1.5	137 000	298 000	14 000	30 500	2 900	4 400	NA6916R
85	115	26	1	95	1.5	74 500	137 000	7 600	14 000	2 800	4 200	NK95/26R + IR85 × 95 × 26
	115	36	1	95	1.5	108 000	223 000	11 100	22 700	2 800	4 200	NK95/36R + IR85 × 95 × 36

Note 1) Allowable minimum chamfer dimension r . 2) Allowable axial stroking value of inner ring against outer ring.
Remarks: Nominal code number of inner ring (IR) comprises the codes of IR bore diameter × outer diameter × width.

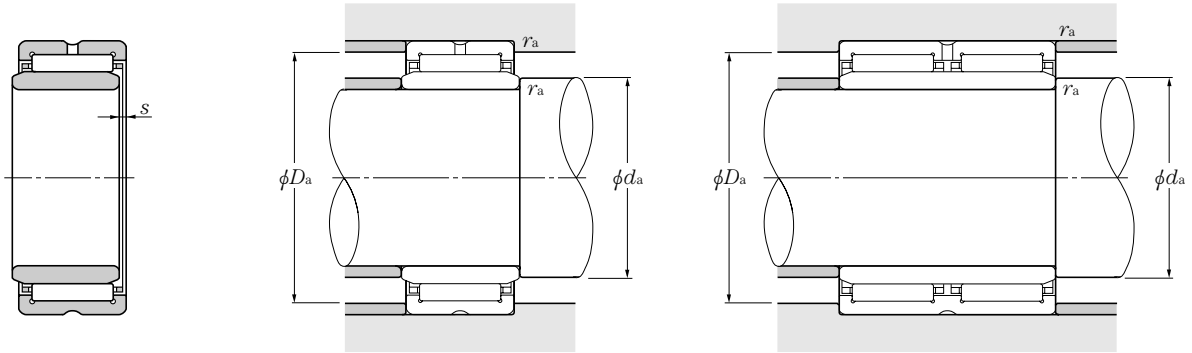

Abutment dimensions			Mass
d_a	mm		kg
min	D_a	r_{as}	(approx.)
	max	max	
60	75	1	0.559
60	75	1	0.726
65	77	0.6	0.393
64	78	0.6	0.551
65	80	1	0.427
65	80	1	0.614
65	80	1	0.758
69	86	0.6	0.466
70	85	1	0.454
70	85	1	0.655
69	86	0.6	0.660
70	85	1	0.779
75	90	1	0.525
75	90	1	0.738
75	95	1	0.727
75	95	1	1.06
75	95	1	1.34
80	100	1	0.642
80	100	1	0.776
80	100	1	0.853
80	100	1	1.13
80	100	1	1.45
85	105	1	0.680
85	105	1	0.820
85	105	1	0.959
85	105	1	1.15
85	105	1	1.53
90	110	1	0.644
90	110	1	1.05

With inner ring

Type NA48
Type NA49
Type NA59
Type NK+IR

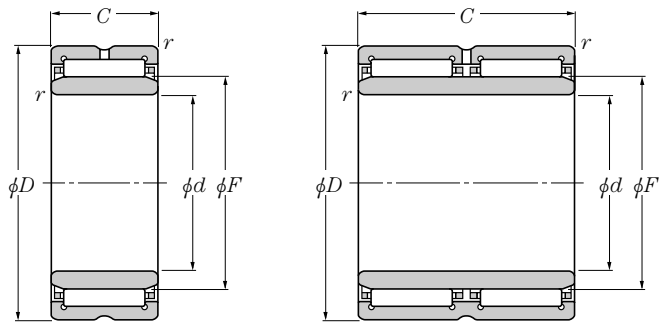

Type NA49·R, Type NA49
Type NA59
Type NK·R+IR, Type NK+IR

Type NA69·R

d 85~130mm

Boundary dimensions						Basic load ratings				Limiting speeds		Bearing numbers
mm						dynamic	static	dynamic	static	r/min		
d	D	C	r _{s min} ¹⁾	F	s ²⁾	N		kgf		grease	oil	
						C _r	C _{0r}	C _r	C _{0r}			
85	120	35	1.1	100	1	112 000	237 000	11 500	24 200	2 700	4 000	NA4917R
	120	46	1.1	100	1.5	137 000	290 000	14 000	29 600	2 700	4 000	NA5917
	120	63	1.1	100	1	169 000	400 000	17 300	41 000	2 700	4 000	NA6917R
90	120	26	1	100	1.5	73 500	137 000	7 500	14 000	2 700	4 000	NK100/26R+IR90×100×26
	120	36	1	100	1.5	107 000	223 000	11 000	22 800	2 700	4 000	NK100/36R+IR90×100×36
	125	35	1.1	105	1	116 000	252 000	11 900	25 700	2 500	3 800	NA4918R
	125	46	1.1	105	1	143 000	310 000	14 600	32 000	2 500	3 800	NA5918
	125	63	1.1	105	1	175 000	425 000	17 900	43 500	2 500	3 800	NA6918R
95	125	26	1	105	1.5	76 500	147 000	7 800	14 900	2 500	3 800	NK105/26R+IR95×105×26
	125	36	1	105	1.5	111 000	238 000	11 400	24 300	2 500	3 800	NK105/36R+IR95×105×36
	130	35	1.1	110	1	118 000	260 000	12 000	26 500	2 400	3 600	NA4919R
	130	46	1.1	110	1	149 000	335 000	15 200	34 000	2 400	3 600	NA5919
	130	63	1.1	110	1	177 000	440 000	18 100	45 000	2 400	3 600	NA6919R
100	130	30	1.1	110	1.5	97 500	204 000	9 950	20 800	2 400	3 600	NK110/30R+IR100×110×30
	130	40	1.1	110	2	129 000	292 000	13 100	29 700	2 400	3 600	NK110/40R+IR100×110×40
	140	40	1.1	115	2	127 000	260 000	12 900	26 500	2 300	3 500	NA4920
	140	54	1.1	115	2	182 000	395 000	18 600	40 500	2 300	3 500	NA5920
110	140	30	1	120	0.8	93 500	210 000	9 550	21 400	2 200	3 300	NA4822
	140	40	1.1	120	—	113 000	268 000	11 500	27 300	2 200	3 300	NK120/40+IR110×120×40
	150	40	1.1	125	2	131 000	279 000	13 300	28 400	2 100	3 200	NA4922
	150	54	1.1	125	2	193 000	440 000	19 700	45 000	2 100	3 200	NA5922
120	150	30	1	130	0.8	99 500	233 000	10 100	23 800	2 100	3 100	NA4824
	150	40	1.1	130	—	116 000	283 000	11 800	28 800	2 100	3 100	NK130/40+IR120×130×40
	165	45	1.1	135	2	180 000	380 000	18 300	38 500	2 000	3 000	NA4924
	165	60	1.1	135	2	245 000	525 000	25 000	53 500	2 000	3 000	NA5924
130	165	35	1.1	145	1	118 000	305 000	12 100	31 000	1 900	2 800	NA4826
	170	32	1.5	145	—	111 000	238 000	11 300	24 300	1 900	2 800	NK145/32+IR130×145×32
	170	42	1.5	145	—	153 000	360 000	15 600	36 500	1 900	2 800	NK145/42+IR130×145×42
	180	50	1.5	150	1.5	202 000	455 000	20 600	46 500	1 800	2 700	NA4926

Note 1) Allowable minimum chamfer dimension r . 2) Allowable axial stroking value of inner ring against outer ring.
Remarks: Nominal code number of inner ring (IR) comprises the codes of IR bore diameter×outer diameter×width.

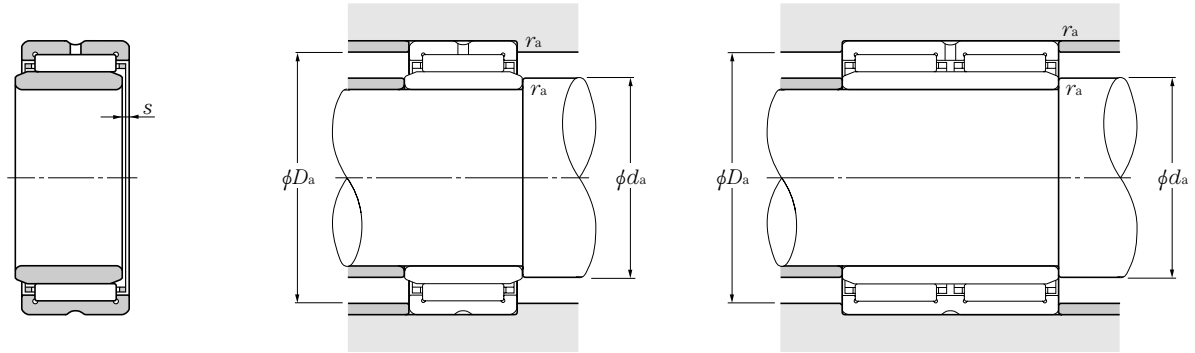

Abutment dimensions			Mass kg (approx.)
d_a min	mm D_a max	r_{as} max	
91.5	113.5	1	1.24
91.5	113.5	1	1.76
91.5	113.5	1	2.25
95	115	1	0.781
95	115	1	1.09
96.5	118.5	1	1.31
96.5	118.5	1	1.84
96.5	118.5	1	2.44
100	120	1	0.819
100	120	1	1.15
101.5	123.5	1	1.36
101.5	123.5	1	1.98
101.5	123.5	1	2.63
106.5	123.5	1	0.990
106.5	123.5	1	1.34
106.5	133.5	1	1.93
106.5	133.5	1	2.85
115	135	1	1.11
116.5	133.5	1	1.49
116.5	143.5	1	2.08
116.5	143.5	1	2.98
125	145	1	1.17
126.5	143.5	1	1.57
126.5	158.5	1	2.84
126.5	158.5	1	3.92
136.5	158.5	1	1.60
138	162.5	1.5	1.90
138	162.5	1.5	2.54
138	172	1.5	3.90

With inner ring

Type NA48
 Type NA49
 Type NA59
 Type NK+IR

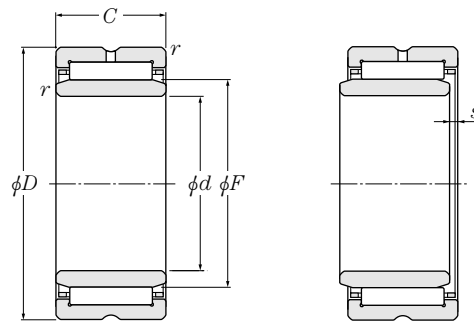

d 130~280mm

Boundary dimensions						Basic load ratings				Limiting speeds		Bearing numbers
mm						dynamic	static	dynamic	static	r/min		
d	D	C	r _{s min} ¹⁾	F	s ²⁾	N		kgf		grease	oil	
						C _r	C _{0r}	C _r	C _{0r}			
130	180	67	1.5	150	1.5	294 000	685 000	30 000	70 000	1 800	2 700	NA5926
	175	35	1.1	155	1	121 000	315 000	12 300	32 500	1 700	2 600	NA4828
140	180	32	1.5	155	—	114 000	252 000	11 600	25 700	1 700	2 600	NK155/32 + IR140×155×32
	180	42	1.5	155	—	156 000	380 000	16 000	38 500	1 700	2 600	NK155/42 + IR140×155×42
	190	50	1.5	160	1.5	209 000	485 000	21 300	49 500	1 700	2 500	NA4928
	190	67	1.5	160	1.5	310 000	755 000	31 500	77 000	1 700	2 500	NA5928
150	190	32	1.5	165	—	117 000	265 000	11 900	27 000	1 600	2 400	NK165/32 + IR150×165×32
	190	40	1.1	165	1.5	152 000	390 000	15 500	40 000	1 600	2 400	NA4830
	190	42	1.5	165	—	160 000	400 000	16 300	40 500	1 600	2 400	NK165/42 + IR150×165×42
	210	60	2	170	1.5	261 000	610 000	26 600	62 500	1 600	2 400	NA4930
160	200	40	1.1	175	1.5	160 000	425 000	16 300	43 500	1 500	2 300	NA4832
	220	60	2	180	1.5	270 000	650 000	27 600	66 500	1 500	2 200	NA4932
170	215	45	1.1	185	1.5	185 000	495 000	18 800	50 500	1 500	2 200	NA4834
	230	60	2	190	1.5	279 000	690 000	28 500	70 500	1 400	2 100	NA4934
180	225	45	1.1	195	1.5	195 000	540 000	19 800	55 000	1 400	2 100	NA4836
	250	69	2	205	1.5	375 000	890 000	38 500	90 500	1 300	2 000	NA4936
190	240	50	1.5	210	1.5	227 000	680 000	23 200	69 000	1 300	1 900	NA4838
	260	69	2	215	1.5	390 000	945 000	40 000	96 500	1 300	1 900	NA4938
200	250	50	1.5	220	1.5	231 000	705 000	23 600	71 500	1 200	1 800	NA4840
	280	80	2.1	225	1.5	505 000	1 180 000	51 500	120 000	1 200	1 800	NA4940
220	270	50	1.5	240	1.5	244 000	780 000	24 900	79 500	1 100	1 700	NA4844
	300	80	2.1	245	1.5	525 000	1 270 000	53 500	129 000	1 100	1 600	NA4944
240	300	60	2	265	2	360 000	1 080 000	37 000	110 000	1 000	1 500	NA4848
	320	80	2.1	265	2	540 000	1 350 000	55 000	138 000	1 000	1 500	NA4948
260	320	60	2	285	2	375 000	1 160 000	38 000	119 000	950	1 400	NA4852
	360	100	2.1	290	2	805 000	1 900 000	82 000	193 000	950	1 400	NA4952
280	350	69	2	305	2.5	455 000	1 300 000	46 500	133 000	850	1 300	NA4856
	380	100	2.1	310	2.5	835 000	2 030 000	85 000	207 000	850	1 300	NA4956

Note 1) Allowable minimum chamfer dimension r . 2) Allowable axial stroking value of inner ring against outer ring.
 Remarks: Nominal code number of inner ring (IR) comprises the codes of IR bore diameter×outer diameter×width.

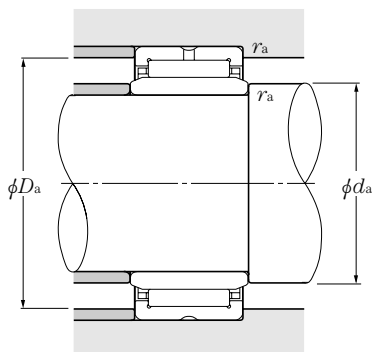

Abutment dimensions			Mass
d_a	mm		kg
min	max	r_{as} max	(approx.)
138	172	1.5	5.60
146.5	168.5	1	1.82
148	172	1.5	2.04
148	172	1.5	2.69
148	182	1.5	4.05
148	182	1.5	6.18
158	182	1.5	2.32
156.5	183.5	1	2.72
158	182	1.5	2.84
159	201	2	5.33
166.5	193.5	1	2.90
169	211	2	5.60
176.5	208.5	1	3.99
179	221	2	5.87
186.5	218.5	1	4.19
189	241	2	8.58
198	232	1.5	5.62
199	251	2	8.68
208	242	1.5	5.84
211	269	2	12.2
228	262	1.5	6.37
231	289	2	13.5
249	291	2	10.0
251	309	2	14.7
269	311	2	10.8
271	349	2	25.9
289	341	2	15.5
291	369	2	27.5

With inner ring

Type NA48

Type NA49

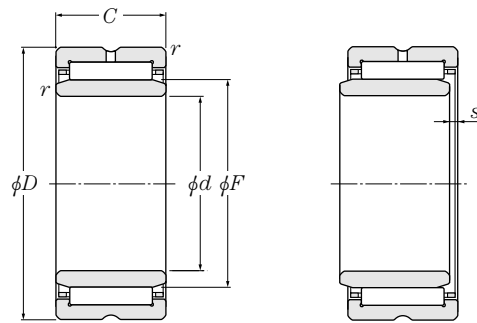

d 300~440mm

Boundary dimensions						Basic load ratings				Limiting speeds		Bearing numbers
mm						dynamic	static	dynamic	static	r/min grease	oil	
d	D	C	$r_{s\min}^{1)}$	F	$s^{2)}$	N C_r	N C_{or}	kgf C_r	kgf C_{or}			
300	380	80	2.1	330	2	625 000	1 770 000	64 000	180 000	800	1 200	NA4860
	420	118	3	340	2	1 080 000	2 640 000	110 000	269 000	800	1 200	NA4960
320	400	80	2.1	350	2	640 000	1 850 000	65 500	189 000	750	1 100	NA4864
	440	118	3	360	2	1 120 000	2 820 000	114 000	288 000	750	1 100	NA4964
340	420	80	2.1	370	2	655 000	1 940 000	66 500	197 000	750	1 100	NA4868
	460	118	3	380	2	1 160 000	3 000 000	118 000	305 000	750	1 100	NA4968
360	440	80	2.1	390	2	665 000	2 020 000	68 000	206 000	650	1 000	NA4872
	480	118	3	400	2	1 200 000	3 200 000	122 000	325 000	650	1 000	NA4972
380	480	100	2.1	415	2	1 000 000	2 840 000	102 000	289 000	650	950	NA4876
	520	140	4	430	2	1 400 000	3 750 000	143 000	385 000	650	950	NA4976
400	540	140	4	450	2.5	1 450 000	4 000 000	148 000	410 000	600	900	NA4980
420	560	140	4	470	2.5	1 500 000	4 250 000	153 000	430 000	550	850	NA4984
440	600	160	4	490	2.5	1 750 000	4 600 000	179 000	470 000	550	800	NA4988

Note 1) Allowable minimum chamfer dimension r . 2) Allowable axial stroking value of inner ring against outer ring.

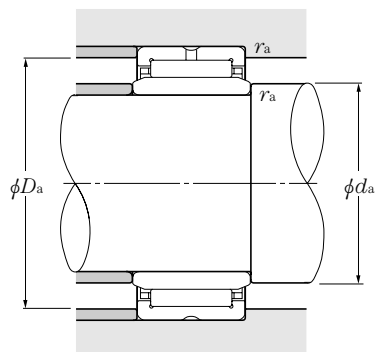

Abutment dimensions			Mass
d_a	mm		kg
min	max	r_{as} max	(approx.)
311	369	2	22.0
313	407	2.5	42.5
331	389	2	23.2
333	427	2.5	45.2
351	409	2	24.1
353	447	2.5	47.3
371	429	2	25.7
373	467	2.5	49.0
391	469	2	44.5
396	504	3	73.6
416	524	3	76.6
436	544	3	89.8
456	584	3	123

Inch series Without inner ring

Type MR

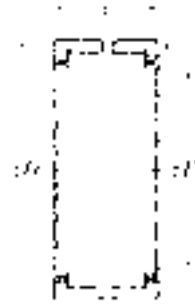

F_w 15.875~63.500mm

F_w	Boundary dimensions				dynamic N	Basic load ratings				Limiting speeds	
	mm ($\frac{1}{25.4}$ mm)					static	dynamic	static	kgf	grease	oil
		D	C	r_s min ¹⁾	C_r	C_{or}	C_r	C_{or}	r/min (approx.)		
15.875 ($\frac{5}{8}$)	+0.027 +0.016	28.575($1\frac{1}{8}$)	19.05($\frac{3}{4}$)	0.6	16 700	16 700	1 700	1 700	17 000	25 000	
		28.575($1\frac{1}{8}$)	25.40(1)	0.6	21 500	23 000	2 190	2 350	17 000	25 000	
19.050 ($\frac{3}{4}$)	+0.033 +0.020	31.750($1\frac{1}{4}$)	19.05($\frac{3}{4}$)	1	19 500	21 100	1 980	2 150	14 000	21 000	
		31.750($1\frac{1}{4}$)	25.40(1)	1	25 000	29 100	2 550	2 970	14 000	21 000	
22.225 ($\frac{7}{8}$)	+0.033 +0.020	34.925($1\frac{3}{8}$)	19.05($\frac{3}{4}$)	1	21 900	25 600	2 240	2 610	12 000	18 000	
		34.925($1\frac{3}{8}$)	25.40(1)	1	28 200	35 500	2 870	3 600	12 000	18 000	
25.400 (1)	+0.033 +0.020	38.100($1\frac{1}{2}$)	19.05($\frac{3}{4}$)	1	23 000	28 100	2 340	2 870	11 000	16 000	
		38.100($1\frac{1}{2}$)	25.40(1)	1	29 500	38 500	3 000	3 950	11 000	16 000	
28.575 ($1\frac{1}{8}$)	+0.033 +0.020	41.275($1\frac{5}{8}$)	25.40(1)	1	32 500	45 000	3 300	4 600	9 500	14 000	
		41.275($1\frac{5}{8}$)	31.75($1\frac{1}{4}$)	1	40 500	60 000	4 100	6 100	9 500	14 000	
31.750 ($1\frac{1}{4}$)	+0.041 +0.025	44.450($1\frac{3}{4}$)	25.40(1)	1	35 000	51 000	3 550	5 200	8 500	13 000	
		44.450($1\frac{3}{4}$)	31.75($1\frac{1}{4}$)	1	43 500	68 000	4 450	6 950	8 500	13 000	
34.925 ($1\frac{3}{8}$)	+0.041 +0.025	47.625($1\frac{7}{8}$)	25.40(1)	1	37 000	57 500	3 800	5 850	7 500	11 000	
		47.625($1\frac{7}{8}$)	31.75($1\frac{1}{4}$)	1	46 500	76 500	4 750	7 800	7 500	11 000	
38.100 ($1\frac{1}{2}$)	+0.041 +0.025	52.388($2\frac{1}{6}$)	25.40(1)	1.5	41 000	61 000	4 150	6 250	7 500	11 000	
		52.388($2\frac{1}{6}$)	31.75($1\frac{1}{4}$)	1.5	51 000	81 500	5 200	8 300	7 500	11 000	
41.275 ($1\frac{5}{8}$)	+0.041 +0.025	55.562($2\frac{3}{6}$)	25.40(1)	1.5	43 500	68 000	4 450	6 950	6 500	9 500	
		55.562($2\frac{3}{6}$)	31.75($1\frac{1}{4}$)	1.5	54 500	90 500	5 550	9 250	6 500	9 500	
44.450 ($1\frac{3}{4}$)	+0.041 +0.025	58.738($2\frac{5}{6}$)	25.40(1)	1.5	44 500	72 000	4 550	7 350	6 000	9 000	
		58.738($2\frac{5}{6}$)	31.75($1\frac{1}{4}$)	1.5	55 500	95 500	5 700	9 750	6 000	9 000	
47.625 ($1\frac{7}{8}$)	+0.041 +0.025	61.912($2\frac{7}{6}$)	31.75($1\frac{1}{4}$)	1.5	59 000	105 000	6 000	10 700	5 500	8 500	
50.800 (2)	+0.049 +0.030	65.088($2\frac{5}{6}$)	25.40(1)	1.5	49 500	86 000	5 050	8 800	5 500	8 000	
		65.088($2\frac{5}{6}$)	31.75($1\frac{1}{4}$)	1.5	62 000	114 000	6 300	11 700	5 500	8 000	
57.150 ($2\frac{1}{4}$)	+0.049 +0.030	76.200(3)	38.10($1\frac{1}{2}$)	1.5	83 500	142 000	8 500	14 500	4 700	7 000	
		76.200(3)	44.45($1\frac{3}{4}$)	1.5	97 000	173 000	9 850	17 600	4 700	7 000	
63.500 ($2\frac{1}{2}$)	+0.049 +0.030	82.550($3\frac{1}{4}$)	38.10($1\frac{1}{2}$)	2	88 000	158 000	8 950	16 100	4 300	6 500	

Note 1) Allowable minimum chamfer dimension r .



Bearing numbers	Abutment dimensions mm		Mass kg (approx.)
	D_a max	r_{as} max	
MR101812	24.5	0.6	0.050
MR101816	24.5	0.6	0.068
MR122012	26.5	1	0.055
MR122016	26.5	1	0.073
MR142212	30	1	0.059
MR142216	30	1	0.082
MR162412	33	1	0.068
MR162416	33	1	0.091
MR182616	36.5	1	0.100
MR182620	36.5	1	0.127
MR202816	39.5	1	0.109
MR202820	39.5	1	0.136
MR223016	42.5	1	0.118
MR223020	42.5	1	0.150
MR243316	46	1.5	0.143
MR243320	46	1.5	0.180
MR263516	49	1.5	0.153
MR263520	49	1.5	0.191
MR283716	52	1.5	0.163
MR283720	52	1.5	0.204
MR303920	55.5	1.5	0.216
MR324116	58.5	1.5	0.183
MR324120	58.5	1.5	0.227
MR364824	69.5	1.5	0.422
MR364828	69.5	1.5	0.493
MR405224	74.5	2	0.472

Inch series

Without inner ring

Type MR

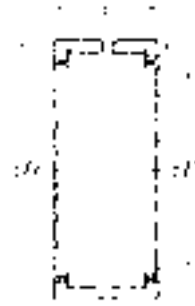

F_w 63.500~184.150mm

Boundary dimensions				Basic load ratings				Limiting speeds		
F_w	mm			dynamic	static	dynamic	static	r/min		
	D	C	$r_{s \min}^1$	C_r	C_{or}	C_r	C_{or}	grease	oil	
63.500(2 1/2)	+0.049 +0.030	82.550(3 1/4)	44.45(1 3/4)	2	102 000	191 000	10 400	19 500	4 300	6 500
	69.850(2 3/4)	88.900(3 1/2)	25.40(1)	2	66 000	112 000	6 700	11 400	3 700	5 500
+0.049 +0.030		88.900(3 1/2)	38.10(1 1/2)	2	92 000	173 000	9 400	17 600	3 700	5 500
88.900(3 1/2)		44.45(1 3/4)	2	107 000	209 000	10 900	21 300	3 700	5 500	
76.200(3)	+0.049 +0.030	95.250(3 3/4)	38.10(1 1/2)	2	96 000	188 000	9 800	19 100	3 300	5 000
	95.250(3 3/4)	44.45(1 3/4)	2	112 000	227 000	11 400	23 200	3 300	5 000	
82.550(3 1/4)	+0.058 +0.036	107.950(4 1/4)	44.45(1 3/4)	2	134 000	240 000	13 600	24 500	3 300	5 000
	107.950(4 1/4)	50.80(2)	2	146 000	268 000	14 900	27 400	3 300	5 000	
88.900(3 1/2)	+0.058 +0.036	114.300(4 1/2)	44.45(1 3/4)	2	141 000	264 000	14 400	26 900	3 000	4 500
	114.300(4 1/2)	50.80(2)	2	154 000	295 000	15 700	30 000	3 000	4 500	
95.250(3 3/4)	+0.058 +0.036	120.650(4 3/4)	50.80(2)	2.5	162 000	320 000	16 500	32 500	2 800	4 200
101.600(4)	+0.058 +0.036	127.000(5)	50.80(2)	2.5	169 000	345 000	17 200	35 500	2 600	3 900
107.950(4 1/4)	+0.058 +0.036	133.350(5 1/4)	50.80(2)	2.5	172 000	360 000	17 500	37 000	2 500	3 700
114.300(4 1/2)	+0.058 +0.036	152.400(6)	57.15(2 1/4)	2.5	238 000	435 000	24 300	44 500	2 300	3 500
	152.400(6)	63.50(2 1/2)	2.5	260 000	485 000	26 500	49 500	2 300	3 500	
127.000(5)	+0.068 +0.043	165.100(6 1/2)	50.80(2)	2.5	227 000	425 000	23 200	43 000	2 100	3 100
		165.100(6 1/2)	57.15(2 1/4)	2.5	250 000	480 000	25 500	49 000	2 100	3 100
		165.100(6 1/2)	63.50(2 1/2)	2.5	273 000	535 000	27 800	54 500	2 100	3 100
139.700(5 1/2)	+0.068 +0.043	177.800(7)	63.50(2 1/2)	2.5	285 000	585 000	29 100	59 500	1 900	2 900
	177.800(7)	76.20(3)	2.5	345 000	740 000	35 000	75 500	1 900	2 900	
146.050(5 3/4)	+0.068 +0.043	184.150(7 1/4)	76.20(3)	3	360 000	775 000	36 500	79 000	1 800	2 700
152.400(6)	+0.068 +0.043	190.500(7 1/2)	63.50(2 1/2)	3	310 000	630 000	31 500	64 000	1 700	2 600
	190.500(7 1/2)	76.20(3)	3	375 000	800 000	38 000	81 500	1 700	2 600	
165.100(6 1/2)	+0.068 +0.043	203.200(8)	63.50(2 1/2)	3	325 000	680 000	33 000	69 500	1 600	2 400
	203.200(8)	76.20(3)	3	390 000	870 000	39 500	88 500	1 600	2 400	
184.150(7 1/4)	+0.079 +0.050	231.775(9 1/8)	76.20(3)	3	435 000	915 000	44 500	93 000	1 500	2 200

Note 1) Allowable minimum chamfer dimension r .



Bearing numbers	Abutment dimensions mm		Mass kg (approx.)
	D_a max	r_{as} max	
MR405228	74.5	2	0.533
MR445616	81	2	0.343
MR445624	81	2	0.504
MR445628	81	2	0.580
MR486024	87	2	0.558
MR486028	87	2	0.651
MR526828	100	2	1.02
MR526832	100	2	1.17
MR567228	106.5	2	1.08
MR567232	106.5	2	1.27
MR607632	111.5	2.5	1.28
MR648032	118	2.5	1.29
MR688432	124.5	2.5	1.36
MR729636	143.5	2.5	2.62
MR729640	143.5	2.5	2.91
MR8010432	156	2.5	2.53
MR8010436	156	2.5	2.87
MR8010440	156	2.5	3.19
MR8811240	169	2.5	3.46
MR8811248	169	2.5	4.16
MR9211648	172	3	4.30
MR9612040	177.5	3	3.74
MR9612048	177.5	3	4.49
MR10412840	190	3	4.02
MR10412848	190	3	4.82
MR11614648	219	3	7.36

Inch series

Without inner ring

Type MR



F_w 196.850~234.950mm

Boundary dimensions					Basic load ratings				Limiting speeds	
mm					dynamic	static	dynamic	static	r/min	
F_w	D	C	r_s min ¹⁾		N		kgf		grease	oil
					C_r	C_{or}	C_r	C_{or}	(approx.)	
196.850(7 $\frac{3}{4}$)	$\begin{matrix} +0.079 \\ +0.050 \end{matrix}$ 244.475(9 $\frac{5}{8}$)	76.20(3)	3		455 000	990 000	46 500	101 000	1 300	2 000
209.550(8 $\frac{1}{4}$)	$\begin{matrix} +0.079 \\ +0.050 \end{matrix}$ 257.175(10 $\frac{1}{8}$)	76.20(3)	3		475 000	1 060 000	48 500	109 000	1 300	1 900
222.250(8 $\frac{3}{4}$)	$\begin{matrix} +0.079 \\ +0.050 \end{matrix}$ 269.875(10 $\frac{5}{8}$)	76.20(3)	4		495 000	1 140 000	50 500	116 000	1 200	1 800
234.950(9 $\frac{1}{4}$)	$\begin{matrix} +0.079 \\ +0.050 \end{matrix}$ 282.575(11 $\frac{1}{8}$)	76.20(3)	4		510 000	1 210 000	52 000	124 000	1 100	1 700

Note 1) Allowable minimum chamfer dimension r_s .



Bearing numbers	Abutment dimensions mm		Mass kg (approx.)
	D_a max	r_{as} max	
MR12415448	231.5	3	7.80
MR13216248	244	3	8.36
MR14017048	254	4	8.81
MR14817848	266.5	4	9.27

Inch series With inner ring

Type MR + MI



d 9.525~34.925mm

d	Boundary dimensions						Basic load ratings			
	D	B	C	r_s min ¹⁾	F	s ²⁾	dynamic N	static	dynamic kgf	static
	mm ($\frac{1}{25.4}$ mm)						C_r	C_{or}	C_r	C_{or}
9.525 ($\frac{3}{8}$)	28.575(1 $\frac{1}{8}$)	19.30	19.05($\frac{3}{4}$)	0.6	15.875	2	16 700	16 700	1 700	1 700
	28.575(1 $\frac{1}{8}$)	25.65	25.40(1)	0.6	15.875	3	21 500	23 000	2 190	2 350
12.700 ($\frac{1}{2}$)	31.750(1 $\frac{1}{4}$)	19.30	19.05($\frac{3}{4}$)	1	19.050	4	19 500	21 100	1 980	2 150
	31.750(1 $\frac{1}{4}$)	25.65	25.40(1)	1	19.050	2	25 000	29 100	2 550	2 970
15.875 ($\frac{5}{8}$)	34.925(1 $\frac{3}{8}$)	19.30	19.05($\frac{3}{4}$)	1	22.225	1	21 900	25 600	2 240	2 610
	34.925(1 $\frac{3}{8}$)	25.65	25.40(1)	1	22.225	2	28 200	35 500	2 870	3 600
17.462 ($\frac{11}{16}$)	34.925(1 $\frac{3}{8}$)	19.30	19.05($\frac{3}{4}$)	1	22.225	1.5	21 900	25 600	2 240	2 610
19.050 ($\frac{3}{4}$)	38.100(1 $\frac{1}{2}$)	19.30	19.05($\frac{3}{4}$)	1	25.400	1	23 000	28 100	2 340	2 870
	38.100(1 $\frac{1}{2}$)	25.65	25.40(1)	1	25.400	1.5	29 500	38 500	3 000	3 950
20.638 ($\frac{13}{16}$)	38.100(1 $\frac{1}{2}$)	25.65	25.40(1)	1	25.400	2	29 500	38 500	3 000	3 950
22.225 ($\frac{7}{8}$)	41.275(1 $\frac{5}{8}$)	25.65	25.40(1)	1	28.575	1.5	32 500	45 000	3 300	4 600
	41.275(1 $\frac{5}{8}$)	32.00	31.75(1 $\frac{1}{4}$)	1	28.575	2	40 500	60 000	4 100	6 100
23.812 ($\frac{15}{16}$)	41.275(1 $\frac{5}{8}$)	25.65	25.40(1)	1	28.575	2	32 500	45 000	3 300	4 600
	41.275(1 $\frac{5}{8}$)	32.00	31.75(1 $\frac{1}{4}$)	1	28.575	2	40 500	60 000	4 100	6 100
25.400 (1)	44.450(1 $\frac{3}{4}$)	25.65	25.40(1)	1	31.750	1.5	35 000	51 000	3 550	5 200
	44.450(1 $\frac{3}{4}$)	32.00	31.75(1 $\frac{1}{4}$)	1	31.750	2	43 500	68 000	4 450	6 950
28.575 (1 $\frac{1}{8}$)	47.625(1 $\frac{7}{8}$)	25.65	25.40(1)	1	34.925	3	37 000	57 500	3 800	5 850
	47.625(1 $\frac{7}{8}$)	32.00	31.75(1 $\frac{1}{4}$)	1	34.925	2	46 500	76 500	4 750	7 800
30.162 (1 $\frac{3}{16}$)	52.388(2 $\frac{1}{16}$)	32.00	31.75(1 $\frac{1}{4}$)	1	38.100	2	51 000	81 500	5 200	8 300
31.750 (1 $\frac{1}{4}$)	52.388(2 $\frac{1}{16}$)	25.65	25.40(1)	1.5	38.100	0.5	41 000	61 000	4 150	6 250
	52.388(2 $\frac{1}{16}$)	32.00	31.75(1 $\frac{1}{4}$)	1.5	38.100	1	51 000	81 500	5 200	8 300
33.338 (1 $\frac{5}{16}$)	55.562(2 $\frac{3}{16}$)	25.65	25.40(1)	1.5	41.275	0.5	43 500	68 000	4 450	6 950
	55.562(2 $\frac{3}{16}$)	32.00	31.75(1 $\frac{1}{4}$)	1.5	41.275	1	54 500	90 500	5 550	9 250
34.925 (1 $\frac{3}{8}$)	55.562(2 $\frac{3}{16}$)	32.00	31.75(1 $\frac{1}{4}$)	1.5	41.275	0.5	54 500	90 500	5 550	9 250
	58.738(2 $\frac{5}{16}$)	25.65	25.40(1)	1.5	44.450	0.5	44 500	72 000	4 550	7 350
	58.738(2 $\frac{5}{16}$)	32.00	31.75(1 $\frac{1}{4}$)	1.5	44.450	1	55 500	95 500	5 700	9 750

Note 1) Allowable minimum chamfer dimension r . 2) Allowable axial stroking value of inner ring against outer ring.



Limiting speeds		Bearing numbers	Abutment dimensions			Mass kg (approx.)
grease	oil		d_a min	mm D_a max	r_{as} max	
17 000	25 000	MR101812+MI-061012	13.5	24.5	0.6	0.069
17 000	25 000	MR101816+MI-061016	13.5	24.5	0.6	0.093
14 000	21 000	MR122012+MI-081212	17.5	26.5	1	0.079
14 000	21 000	MR122016+MI-081216	17.5	26.5	1	0.105
12 000	18 000	MR142212+MI-101412	21	30	1	0.086
12 000	18 000	MR142216+MI-101416	21	30	1	0.118
12 000	18 000	MR142212+MI-111412	21	30	1	0.079
11 000	16 000	MR162412+MI-121612	24	33	1	0.102
11 000	16 000	MR162416+MI-121616	24	33	1	0.136
11 000	16 000	MR162416+MI-131616	24	33	1	0.125
9 500	14 000	MR182616+MI-141816	27	36.5	1	0.152
9 500	14 000	MR182620+MI-141820	27	36.5	1	0.193
9 500	14 000	MR182616+MI-151816	27	36.5	1	0.139
9 500	14 000	MR182620+MI-151820	27	36.5	1	0.176
8 500	13 000	MR202816+MI-162016	30.5	39.5	1	0.161
8 500	13 000	MR202820+MI-162020	30.5	39.5	1	0.201
7 500	11 000	MR223016+MI-182216	33.5	42.5	1	0.181
7 500	11 000	MR223020+MI-182220	33.5	42.5	1	0.229
7 500	11 000	MR243320+MI-192420	35	46	1.5	0.286
7 500	11 000	MR243316+MI-202416	37	46	1.5	0.230
7 500	11 000	MR243320+MI-202420	37	46	1.5	0.285
6 500	9 500	MR263516+MI-212616	40	49	1.5	0.257
6 500	9 500	MR263520+MI-212620	40	49	1.5	0.325
6 500	9 500	MR263520+MI-222620	40	49	1.5	0.286
6 000	9 000	MR283716+MI-222816	41.5	52	1.5	0.294
6 000	9 000	MR283720+MI-222820	41.5	52	1.5	0.364

Inch series

With inner ring

Type MR + MI



d 36.512~66.675mm

d	Boundary dimensions						Basic load ratings			
	mm ($\frac{1}{25.4}$ mm)						dynamic	static	dynamic	static
	D	B	C	r_s min ¹⁾	F	S ²⁾	N	N	kgf	kgf
36.512 (1 $\frac{7}{16}$)	58.738(2 $\frac{5}{16}$)	25.65	25.40(1)	1.5	44.450	0.5	44 500	72 000	4 550	7 350
	58.738(2 $\frac{5}{16}$)	32.00	31.75(1 $\frac{1}{4}$)	1.5	44.450	0.5	55 500	95 500	5 700	9 750
38.100 (1 $\frac{1}{2}$)	58.738(2 $\frac{5}{16}$)	25.65	25.40(1)	1.5	44.450	0.5	44 500	72 000	4 550	7 350
	58.738(2 $\frac{5}{16}$)	32.00	31.75(1 $\frac{1}{4}$)	1.5	44.450	0.5	55 500	95 500	5 700	9 750
39.688 (1 $\frac{9}{16}$)	65.088(2 $\frac{9}{16}$)	32.00	31.75(1 $\frac{1}{4}$)	1.5	50.800	0.5	62 000	114 000	6 300	11 700
	65.088(2 $\frac{9}{16}$)	32.00	31.75(1 $\frac{1}{4}$)	1.5	50.800	0.5	62 000	114 000	6 300	11 700
41.275 (1 $\frac{5}{8}$)	61.912(2 $\frac{7}{16}$)	25.65	25.40(1)	1.5	47.625	1	59 000	105 000	6 000	10 700
	65.088(2 $\frac{9}{16}$)	32.00	31.75(1 $\frac{1}{4}$)	1.5	50.800	0.5	62 000	114 000	6 300	11 700
42.682 (1 $\frac{11}{16}$)	65.088(2 $\frac{9}{16}$)	25.65	25.40(1)	1.5	50.800	0.5	49 500	86 000	5 050	8 800
	65.088(2 $\frac{9}{16}$)	32.00	31.75(1 $\frac{1}{4}$)	1.5	50.800	0.5	62 000	114 000	6 300	11 700
44.450 (1 $\frac{3}{4}$)	76.200(3)	38.35	38.10(1 $\frac{1}{2}$)	1.5	57.150	3.5	83 500	142 000	8 500	14 500
	76.200(3)	44.70	44.45(1 $\frac{3}{4}$)	1.5	57.150	3.5	97 000	173 000	9 850	17 600
49.212 (1 $\frac{15}{16}$)	82.550(3 $\frac{1}{4}$)	38.35	38.10(1 $\frac{1}{2}$)	2	63.500	1.5	88 000	158 000	8 950	16 100
	82.550(3 $\frac{1}{4}$)	44.70	44.45(1 $\frac{3}{4}$)	2	63.500	2	102 000	191 000	10 400	19 500
50.800 (2)	82.550(3 $\frac{1}{4}$)	38.35	25.40(1)	2	63.500	2.5	88 000	158 000	8 950	16 100
	82.550(3 $\frac{1}{4}$)	44.70	44.45(1 $\frac{3}{4}$)	2	63.500	3	102 000	191 000	10 400	19 500
55.562 (2 $\frac{3}{8}$)	88.900(3 $\frac{1}{2}$)	44.70	44.45(1 $\frac{3}{4}$)	2	69.850	1.5	107 000	209 000	10 900	21 300
	88.900(3 $\frac{1}{2}$)	25.65	25.40(1)	2	69.850	0.5	66 000	112 000	6 700	11 400
57.150 (2 $\frac{1}{4}$)	88.900(3 $\frac{1}{2}$)	38.35	38.10(1 $\frac{1}{2}$)	2	69.850	2.5	92 000	173 000	9 400	17 600
	88.900(3 $\frac{1}{2}$)	44.70	44.45(1 $\frac{3}{4}$)	2	69.850	3	107 000	209 000	10 900	21 300
60.325 (2 $\frac{3}{8}$)	95.250(3 $\frac{3}{4}$)	44.70	44.45(1 $\frac{3}{4}$)	2	76.200	1.5	112 000	227 000	11 400	23 200
	95.250(3 $\frac{3}{4}$)	38.35	38.10(1 $\frac{1}{2}$)	2	76.200	2.5	96 000	188 000	9 800	19 100
63.500 ($\frac{1}{2}$)	95.250(3 $\frac{3}{4}$)	44.70	44.45(1 $\frac{3}{4}$)	2	76.200	3	112 000	227 000	11 400	23 200
	107.950(4 $\frac{1}{4}$)	44.70	44.45(1 $\frac{3}{4}$)	2	82.550	3	134 000	240 000	13 600	24 500
66.675 (2 $\frac{5}{8}$)	107.950(4 $\frac{1}{4}$)	51.05	50.80(2)	2	82.550	5.5	146 000	268 000	14 900	27 400

Note 1) Allowable minimum chamfer dimension r_s . 2) Allowable axial stroking value of inner ring against outer ring.



Limiting speeds		Bearing numbers	Abutment dimensions			Mass kg (approx.)
r/min grease	oil		d_a min	mm D_a max	r_{as} max	
6 000	9 000	MR283716+MI-232816	43	52	1.5	0.264
6 000	9 000	MR283720+MI-232820	43	52	1.5	0.330
6 000	9 000	MR283716+MI-242816	43	52	1.5	0.246
6 000	9 000	MR283720+MI-242820	43	52	1.5	0.307
5 500	8 000	MR324120+MI-243220	44.5	58.5	1.5	0.448
5 500	8 500	MR303920+MI-253020	46.5	55.5	1.5	0.368
5 500	8 000	MR324120+MI-253220	46	58.5	1.5	0.424
5 500	8 000	MR324116+MI-263216	48	58.5	1.5	0.317
5 500	8 000	MR324120+MI-263220	48	58.5	1.5	0.402
5 500	8 000	MR324116+MI-273216	49.5	58.5	1.5	0.300
5 500	8 000	MR324120+MI-273220	49.5	58.5	1.5	0.373
4 700	7 000	MR364824+MI-283624	51	69.5	1.5	0.732
4 700	7 000	MR364828+MI-283628	51	69.5	1.5	0.853
4 300	6 500	MR405224+MI-314024	56	74.5	2	0.848
4 300	6 500	MR405228+MI-314028	56	74.5	2	0.975
4 300	6 500	MR405224+MI-324024	59	74.5	2	0.812
4 300	6 500	MR405228+MI-324028	59	74.5	2	0.923
3 700	5 500	MR445628+MI-354428	63.5	81	2	1.07
3 700	5 500	MR445616+MI-364416	65	81	2	0.594
3 700	5 500	MR445624+MI-364424	65	81	2	0.884
3 700	5 500	MR445628+MI-364428	65	81	2	1.02
3 300	5 000	MR486028+MI-384828	68	87	2	1.25
3 300	5 000	MR486024+MI-404824	71.5	87	2	0.978
3 300	5 000	MR486028+MI-404828	71.5	87	2	1.14
3 300	5 000	MR526828+MI-425228	74.5	100	2	1.67
3 300	5 000	MR526832+MI-425232	74.5	100	2	1.92

Inch series

With inner ring

Type MR + MI



d 69.850~127.000mm

Boundary dimensions							Basic load ratings			
mm ($\frac{1}{25.4}$ mm)							dynamic	static	dynamic	static
d	D	B	C	$r's \min^1)$	F	$s^2)$	C_r	C_{or}	C_r	C_{or}
							N		kgf	
69.850(2 $\frac{3}{4}$)	107.950(4 $\frac{1}{4}$)	44.70	44.45(1 $\frac{3}{4}$)	2	82.550	1.5	134 000	240 000	13 600	24 500
	107.950(4 $\frac{1}{4}$)	51.05	50.80(2)	2	82.550	3	146 000	268 000	14 900	27 400
74.612(2 $\frac{15}{16}$)	114.300(4 $\frac{1}{2}$)	51.05	50.80(2)	2	88.900	3	154 000	295 000	15 700	30 000
76.200(3)	114.300(4 $\frac{1}{2}$)	44.70	44.45(1 $\frac{3}{4}$)	2	88.900	3	141 000	264 000	14 400	26 900
	114.300(4 $\frac{1}{2}$)	51.05	50.80(2)	2	88.900	5.5	154 000	295 000	15 700	30 000
79.375(3 $\frac{1}{8}$)	120.650(4 $\frac{3}{4}$)	51.05	50.80(2)	2.5	95.250	5.5	162 000	320 000	16 500	32 500
82.550(3 $\frac{1}{4}$)	120.650(4 $\frac{3}{4}$)	51.05	50.80(2)	2.5	95.250	2.5	162 000	320 000	16 500	32 500
	127.000(5)	51.05	50.80(2)	2.5	101.600	2.5	169 000	345 000	17 200	35 500
85.725(3 $\frac{3}{8}$)	127.000(5)	51.05	50.80(2)	2.5	101.600	4.5	169 000	345 000	17 200	35 500
88.900(3 $\frac{1}{2}$)	127.000(5)	51.05	50.80(2)	2.5	101.600	2.5	169 000	345 000	17 200	35 500
	133.350(5 $\frac{1}{4}$)	51.05	50.80(2)	2.5	107.950	2.5	172 000	360 000	17 500	37 000
92.075(3 $\frac{5}{8}$)	133.350(5 $\frac{1}{4}$)	51.05	50.80(2)	2.5	107.950	4.5	172 000	360 000	17 500	37 000
95.250(3 $\frac{3}{4}$)	133.350(5 $\frac{1}{4}$)	51.05	50.80(2)	2.5	107.950	2.5	172 000	360 000	17 500	37 000
	152.400(6)	57.40	57.15(2 $\frac{1}{4}$)	2.5	114.300	3	238 000	435 000	24 300	44 500
	152.400(6)	63.88	63.50(2 $\frac{1}{2}$)	2.5	114.300	4	260 000	485 000	26 500	49 500
98.425(3 $\frac{7}{8}$)	152.400(6)	57.40	57.15(2 $\frac{1}{4}$)	2.5	114.300	5.5	238 000	435 000	24 300	44 500
	152.400(6)	63.88	63.50(2 $\frac{1}{2}$)	2.5	114.300	7	260 000	485 000	26 500	49 500
101.600(4)	165.100(6 $\frac{1}{2}$)	51.05	50.80(2)	2.5	127.000	2.5	227 000	425 000	23 200	43 000
	165.100(6 $\frac{1}{2}$)	57.40	57.15(2 $\frac{1}{4}$)	2.5	127.000	5.5	250 000	480 000	25 500	49 000
	165.100(6 $\frac{1}{2}$)	63.88	57.15(2 $\frac{1}{4}$)	2.5	127.000	7	273 000	535 000	27 800	54 500
107.950(4 $\frac{1}{4}$)	165.100(6 $\frac{1}{2}$)	57.40	57.15(2 $\frac{1}{4}$)	2.5	127.000	3	250 000	480 000	25 500	49 000
114.300(4 $\frac{1}{2}$)	177.800(7)	63.88	63.50(2 $\frac{1}{2}$)	2.5	139.700	5.5	285 000	585 000	29 100	59 500
	177.800(7)	76.58	76.20(3)	2.5	139.700	7	345 000	740 000	35 000	75 500
120.650(4 $\frac{3}{4}$)	184.150(7 $\frac{1}{4}$)	82.55	76.20(3)	3	146.050	3	360 000	775 000	36 500	79 000
127.000(5)	190.500(7 $\frac{1}{2}$)	63.88	63.50(2 $\frac{1}{2}$)	3	152.400	7	310 000	630 000	31 500	64 000
	190.500(7 $\frac{1}{2}$)	76.58	76.20(3)	3	152.400	5.5	375 000	800 000	38 000	81 500

Note 1) Allowable minimum chamfer dimension r . 2) Allowable axial stroking value of inner ring against outer ring.

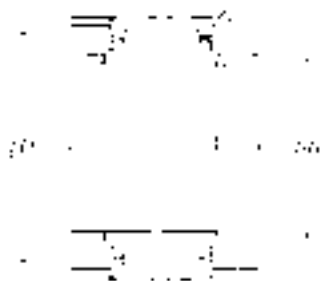

Limiting speeds		Bearing numbers	Abutment dimensions			Mass kg (approx.)
r/min grease	oil		d_a min	mm D_a max	r_{as} max	
3 300	5 000	MR526828 + MI-445228	78	100	2	1.55
3 300	5 000	MR526832 + MI-445232	78	100	2	1.77
3 000	4 500	MR567232 + MI-475632	83	106.5	2	2.00
3 000	4 500	MR567228 + MI-485628	84	106.5	2	1.65
3 000	4 500	MR567232 + MI-485632	84	106.5	2	1.92
2 800	4 200	MR607632 + MI-506032	88.5	111.5	2.5	2.15
2 800	4 200	MR607632 + MI-526032	91.5	111.5	2.5	1.99
2 600	3 900	MR648032 + MI-526432	91.5	118	2.5	2.39
2 600	3 900	MR648032 + MI-546432	94.5	118	2.5	2.22
2 600	3 900	MR648032 + MI-566432	98	118	2.5	2.05
2 500	3 700	MR688432 + MI-566832	98	124.5	2.5	2.53
2 500	3 700	MR688432 + MI-586832	101	124.5	2.5	2.36
2 500	3 700	MR688432 + MI-606832	104.5	124.5	2.5	2.17
2 300	3 500	MR729636 + MI-607236	104.5	143.5	2.5	4.02
2 300	3 500	MR729640 + MI-607240	104.5	143.5	2.5	4.47
2 300	3 500	MR729636 + MI-627236	107.5	143.5	2.5	3.77
2 300	3 500	MR729640 + MI-627240	107.5	143.5	2.5	4.19
2 100	3 100	MR8010432 + MI-648032	110.5	156	2.5	3.60
2 100	3 100	MR8010436 + MI-648036	110.5	156	2.5	4.92
2 100	3 100	MR8010440 + MI-648040	110.5	156	2.5	5.47
2 100	3 100	MR8010436 + MI-688036	117	156	2.5	4.44
1 900	2 900	MR8811240 + MI-728840	123.5	169	2.5	6.04
1 900	2 900	MR8811248 + MI-728848	123.5	169	2.5	7.26
1 800	2 700	MR9211648 + MI-769248	132	172	3	7.48
1 700	2 600	MR9612040 + MI-809640	140	177.5	3	6.54
1 700	2 600	MR9612048 + MI-809648	140	177.5	3	7.84

Inch series
With inner ring

Type MR + MI



d 139.700~203.200mm

d	D	Boundary dimensions					Basic load ratings			
		B	C	r_s min ¹⁾	F	s ²⁾	dynamic N	static	dynamic kgf	static
		mm ($\frac{1}{25.4}$ mm)					C_r	C_{or}	C_r	C_{or}
139.700(5 1/2)	203.200(8)	63.88	63.50(2 1/2)	3	165.100	6	325 000	680 000	33 000	69 500
	203.200(8)	76.58	76.20(3)	3	165.100	5.5	390 000	870 000	39 500	88 500
152.400(6)	231.775(9 1/8)	76.58	76.20(3)	3	184.150	8.5	435 000	915 000	44 500	93 000
165.100(6 1/2)	244.475(9 5/8)	76.58	76.20(3)	3	196.850	8.5	455 000	990 000	46 500	101 000
177.800(7)	257.175(10 1/8)	76.58	76.20(3)	3	209.550	8.5	475 000	1 060 000	48 500	109 000
190.500(7 1/2)	269.875(10 5/8)	76.58	76.20(3)	4	222.250	7	495 000	1 140 000	50 500	116 000
203.200(8)	282.575(11 1/8)	76.58	76.20(3)	4	234.950	7	510 000	1 210 000	52 000	124 000

Note 1) Allowable minimum chamfer dimension r . 2) Allowable axial stroking value of inner ring against outer ring.



Limiting speeds		Bearing numbers	Abutment dimensions			Mass kg (approx.)
grease	oil		d_a min	mm D_a max	r_{as} max	
1 600	2 400	MR10412840+MI-8810440	152.5	190	3	6.86
1 600	2 400	MR10412848+MI-8810448	152.5	190	3	8.22
1 500	2 200	MR11614648+MI-9611648	165.5	219	3	12.2
1 300	2 000	MR12415448+MI-10412448	178	231.5	3	13.1
1 300	1 900	MR13216248+MI-11213248	191	244	3	14.0
1 200	1 800	MR14017048+MI-12014048	206.5	254	4	15.0
1 100	1 700	MR14817848+MI-12814848	219	266.5	4	15.8

Without inner ring

Type RNA49··L
Type RNA49··LL



Type RNA49··L
(With single seal)



Type RNA49··LL
(With double seal)



F_w 14~58mm

Boundary dimensions				Basic load ratings				Limiting speeds r/min grease	Bearing numbers		Abutment dimensions			Mass kg (approx.)	
mm				dynamic	static	dynamic	static		Type	Type	D_a	D_b	r_{as}		
F_w	D	C	$r_s \text{ min}^{1)}$	C_r	C_{or}	C_r	C_{or}	RNA49··L	RNA49··LL	max	max	max			
14	$\begin{smallmatrix} +0.027 \\ +0.016 \end{smallmatrix}$	22	13	0.3	7 200	8 500	735	865	10 000	RNA4900L	RNA4900LL	16	20	0.3	0.016
16	$\begin{smallmatrix} +0.027 \\ +0.016 \end{smallmatrix}$	24	13	0.3	7 750	9 700	795	990	10 000	RNA4901L	RNA4901LL	18	22	0.3	0.018
20	$\begin{smallmatrix} +0.033 \\ +0.020 \end{smallmatrix}$	28	13	0.3	8 300	11 200	845	1 150	10 000	RNA4902L	RNA4902LL	22	26	0.3	0.022
22	$\begin{smallmatrix} +0.033 \\ +0.020 \end{smallmatrix}$	30	13	0.3	8 500	11 900	865	1 220	9 000	RNA4903L	RNA4903LL	24	28	0.3	0.022
25	$\begin{smallmatrix} +0.033 \\ +0.020 \end{smallmatrix}$	37	17	0.3	15 200	19 900	1 550	2 030	8 000	RNA4904L	RNA4904LL	28	35	0.3	0.055
30	$\begin{smallmatrix} +0.033 \\ +0.020 \end{smallmatrix}$	42	17	0.3	16 000	22 600	1 640	2 300	6 500	RNA4905L	RNA4905LL	33	40	0.3	0.063
35	$\begin{smallmatrix} +0.041 \\ +0.025 \end{smallmatrix}$	47	17	0.3	18 000	27 400	1 830	2 800	5 500	RNA4906L	RNA4906LL	38	45	0.3	0.072
42	$\begin{smallmatrix} +0.041 \\ +0.025 \end{smallmatrix}$	55	20	0.6	22 700	39 500	2 320	4 000	4 800	RNA4907L	RNA4907LL	45	51	0.6	0.113
48	$\begin{smallmatrix} +0.041 \\ +0.025 \end{smallmatrix}$	62	22	0.6	27 800	53 500	2 830	5 450	4 200	RNA4908L	RNA4908LL	51	58	0.6	0.154
52	$\begin{smallmatrix} +0.049 \\ +0.030 \end{smallmatrix}$	68	22	0.6	28 600	57 000	2 920	5 800	3 800	RNA4909L	RNA4909LL	55	64	0.6	0.157
58	$\begin{smallmatrix} +0.049 \\ +0.030 \end{smallmatrix}$	72	22	0.6	30 500	64 000	3 100	6 500	3 400	RNA4910L	RNA4910LL	61	68	0.6	0.160

Note 1) Allowable minimum chamfer dimension r .

With inner ring

Type NA49··L
Type NA49··LL

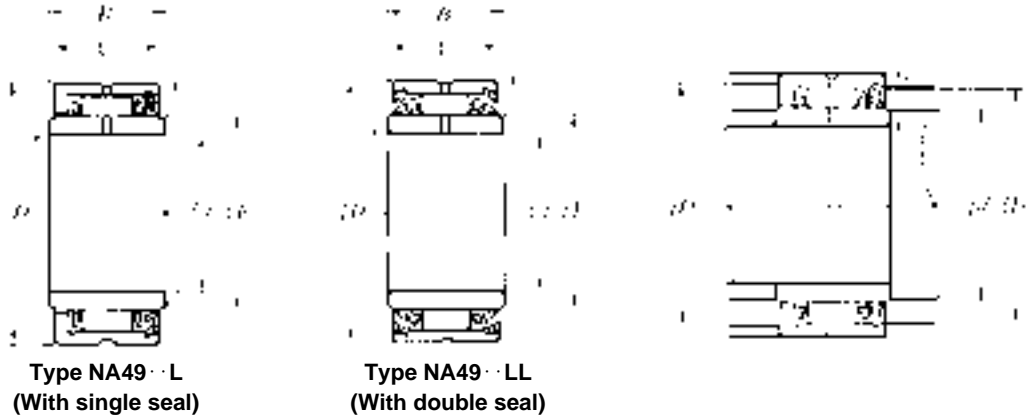

d 10~50mm

Boundary dimensions						Basic load ratings				Limiting speeds r/min grease	Bearing numbers		Abutment dimensions				Mass kg (approx.)
mm						dynamic N	static N	dynamic kgf	static kgf		Type NA49··L	Type RNA49··LL	d_a min	D_a max	D_b max	r_{as} max	
d	D	B	C	$r_{s\ min}^1$	F	C_r	C_{or}	C_r	C_{or}								
10	22	14	13	0.3	14	7 200	8 500	735	865	10 000	NA4900L	NA4900LL	12	16	20	0.3	0.025
12	24	14	13	0.3	16	7 750	9 700	795	990	10 000	NA4901L	NA4901LL	14	18	22	0.3	0.028
15	28	14	13	0.3	20	8 300	11 200	845	1 150	10 000	NA4902L	NA4902LL	17	22	26	0.3	0.036
17	30	14	13	0.3	22	8 500	11 900	865	1 220	9 000	NA4903L	NA4903LL	19	24	28	0.3	0.039
20	37	18	17	0.3	25	15 200	19 900	1 550	2 030	8 000	NA4904L	NA4904LL	22	28	35	0.3	0.080
25	42	18	17	0.3	30	16 000	22 600	1 640	2 300	6 500	NA4905L	NA4905LL	27	33	40	0.3	0.093
30	47	18	17	0.3	35	18 000	27 400	1 830	2 800	5 500	NA4906L	NA4906LL	32	38	45	0.3	0.107
35	55	21	20	0.6	42	22 700	39 500	2 320	4 000	4 800	NA4907L	NA4907LL	39	45	51	0.6	0.175
40	62	23	22	0.6	48	27 800	53 500	2 830	5 450	4 200	NA4908L	NA4908LL	44	51	58	0.6	0.252
45	68	23	22	0.6	52	28 600	57 000	2 920	5 800	3 800	NA4909L	NA4909LL	49	55	64	0.6	0.290
50	72	23	22	0.6	58	30 500	64 000	3 100	6 500	3 400	NA4910L	NA4910LL	54	61	68	0.6	0.295

Note 1) Allowable minimum chamfer dimension r .

Machined Ring Needle Roller Bearings, Separable Type

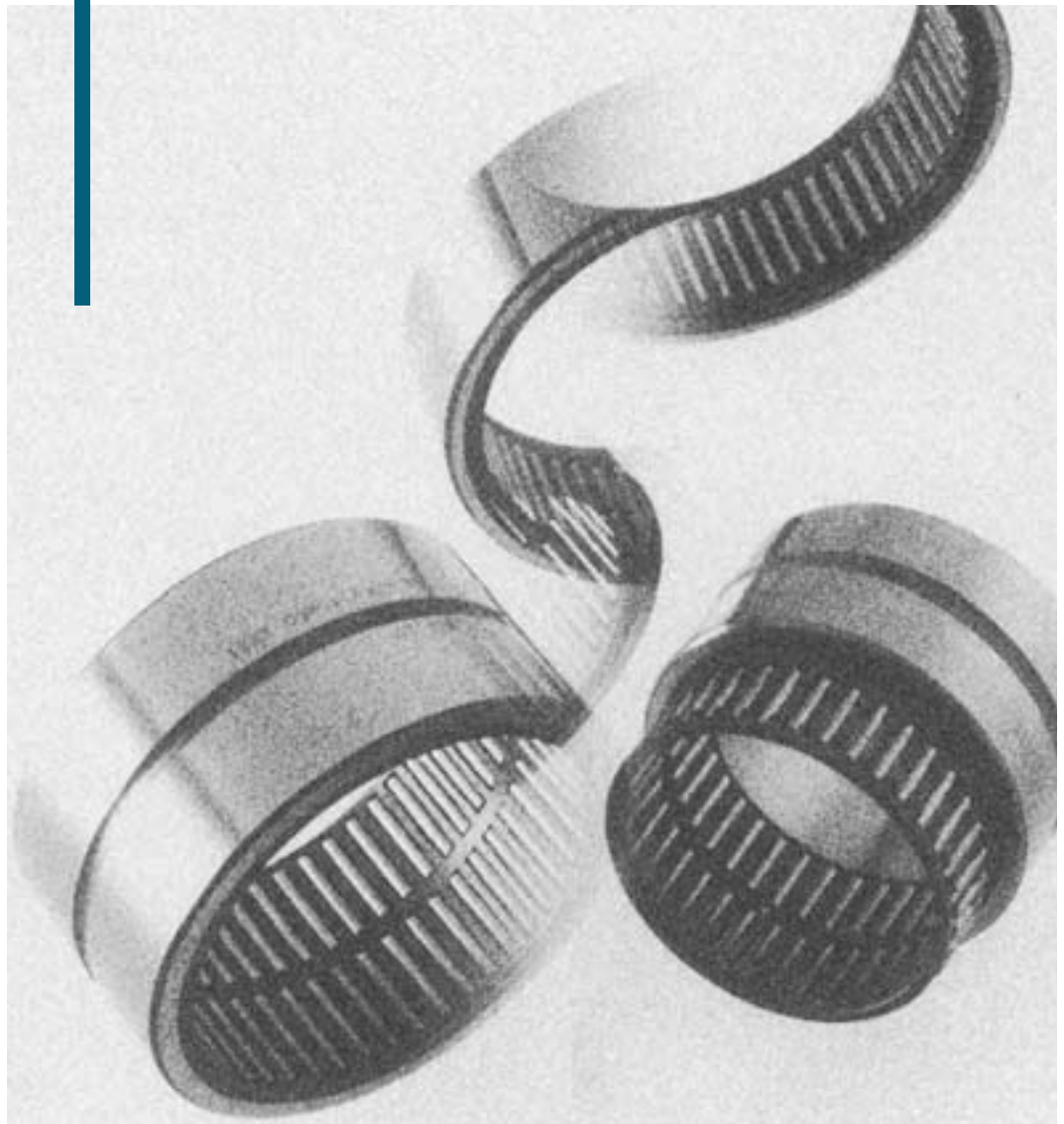

Machined Ring Needle Roller Bearings, Separable Type

The machined ring of this bearing type has no rib or side plate and, hence, the outer ring and the needle roller and cage assembly are separable from each other.

The outer ring can't regulate axial displacement of the needle roller and cage assembly and, therefore, the bearing construction must be so designed that the needle roller and cage assembly can be guided by a shaft or a housing. Furthermore, the outer ring, the needle roller

and cage assembly separable from one another, and the inner ring can be press-fitted individually in a shaft or a housing. This could facilitate the bearing mounting work.

This bearing type is suitable for an application requiring high running accuracy because the resultant radial clearance can be retained in a narrow range by selection and combination of appropriate inner ring, outer ring and needle roller and cage assembly.

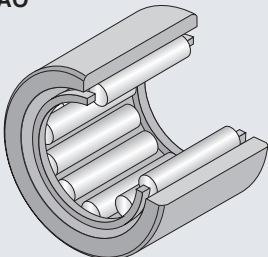
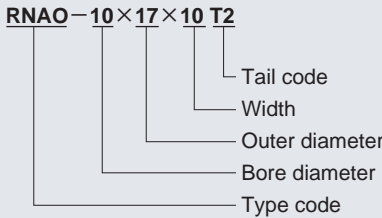
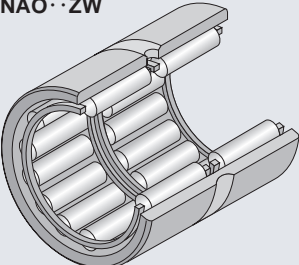
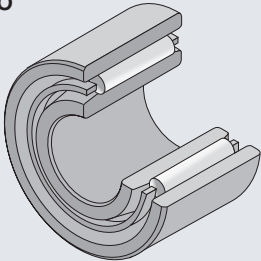
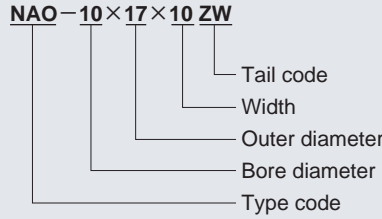
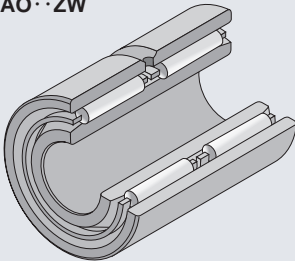
Bearing type	Applied shaft diameter (mm)	Composition of nominal bearing number	Remarks
Type RNAO 	$\phi 5 \sim \phi 100$	RNAO-10×17×10 T2 	
Type RNAO · ZW 	$\phi 8 \sim \phi 80$	[Tail code] T2 : Resin cage ZW: Double-row type	Bearing with tail code T2 uses a polyamide resin cage and, therefore, it shall be used at allowable temperature 120°C and, under continuous running, at 100°C and less.
Type NAO 	$\phi 8 \sim \phi 90$	NAO-10×17×10 ZW 	For an application requiring high running accuracy, manufacture of the bearings conforming to JIS Class-6, -5 and -4 is also available on special request.
Type NAO · ZW 	$\phi 10 \sim \phi 70$	[Tail code] T2 : Resin cage ZW: Double-row type	

Accuracy of bearing

The dimensional accuracy, profile accuracy and running accuracy of machined ring needle roller bearing, separate type (with inner ring) are specified in JIS B 1514 (Accuracy of Rolling Bearings). (Refer to **Table 4.3** of Section 4. "Bearing Tolerances" on page A-26.) Although the accuracy of NTN standard bearings conforms to JIS Class-0, NTN can also supply bearings conforming to JIS Class-6, -5 and -4. Feel free to contact NTN for the further detail of these bearings.

The dimensional tolerances for the roller inscribed circle diameters (F_w) of the bearing type without inner ring conform to ISO Tolerance Range Class-F6. The outer ring and the needle roller and cage assembly are supplied in set and, therefore, the bearing must be installed with the combination of these two in set remained unchanged.

Particularly when high bearing accuracy is required, a bearing with grinding allowance for its inner ring raceway surface can be supplied upon request from a client. In that case, however, the client is requested to finish the inner ring to the intended dimension after having installed on a shaft.

Radial clearance and bearing fits

Table 5.1 of Subsection 5.1 "Radial Clearance in Bearings" (page A-30) shows the radial clearance of bearings with inner ring. Because of the narrow non-interchangeable clearance range, the bearings shipped after adjusted to a specific non-interchangeable clearance must be installed with the clearance remained unchanged.

The respective fitting tolerances for shaft and housing bore on/in which bearing with inner ring is press-fitted are per **Table 6.3** of 6.4 "Recommended Bearing Fits" (page A-34) which specifies them according to load characteristic, load magnitude, and shaft and housing bore sizes.

The profile accuracy and surface roughness of shaft and housing to be applied are as specified in **Table 7.3** of 7.3 "Shaft and Housing Accuracy" (page A-39).

A shaft is used as the direct raceway surface for a bearing without inner ring and, in this case, the shaft diameter (raceway diameter) tolerance is per Table 1 specifying the tolerances according to each running clearance. And K7 tolerance generally in broad use is applied as the dimensional tolerance for the housing bore. Feel free to contact NTN for application of housing bore tolerance other than K7.

For the profile accuracy, surface roughness and hardness of a shaft acting as the raceway surface, refer to **Table 7.4** of 7.4 "Raceway Surface Accuracy" (page A-39).

Dimension of oil hole in outer ring

The outer ring of bearing Type ZW is provided with an oil hole and an oil groove to facilitate oil lubrication to bearing.

Table 1 shows the oil hole dimension every outer ring diameter.

Table 1 Oil hole dimension

Outer ring outer diameter		Oil hole dia. (mm)	Number of oil hole
over	incl.		
—	20	2.0	1
20	40	2.5	1
40	80	3.0	1
80	200	3.5	1

Mounting relations

The inner ring and outer ring of any machined ring needle roller bearing, separable type must both be positioned in axial direction by shoulder or a snap ring.

For the shoulder dimension and corner roundness (r_a) of the shaft and the housing are as specified in applicable "Dimensions Table". The cage must be guided by the shaft or the side face of the housing shoulder, but the guide surface must be finished by, at least, grinding for deburring.

Without inner ring

Type RNAO
Type RNAO ··ZW

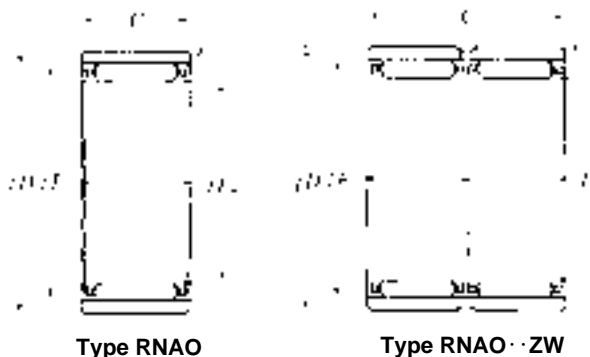

F_w 5~20mm

	Boundary dimensions				Basic load ratings				Limiting speeds		Bearing numbers	
	F_w	D	C	$r_{s \min}^1$	E	dynamic N	static	dynamic kgf	static	grease		oil
5	$\begin{matrix} +0.018 \\ +0.010 \end{matrix}$	10	8	0.15	8	2 640	2 190	269	224	27 000	40 000	RNAO- 5×10×8T2
6	$\begin{matrix} +0.018 \\ +0.010 \end{matrix}$	13	8	0.3	9	2 660	2 280	272	233	25 000	37 000	RNAO- 6×13×8T2
7	$\begin{matrix} +0.022 \\ +0.013 \end{matrix}$	14	8	0.3	10	2 670	2 350	272	239	23 000	34 000	RNAO- 7×14×8T2
8	$\begin{matrix} +0.022 \\ +0.013 \end{matrix}$	15	10	0.3	11	4 000	4 100	410	420	21 000	32 000	RNAO- 8×15×10T2
		16	20	0.3	12	7 950	8 350	810	850	21 000	32 000	RNAO- 8×16×20ZW T2
10	$\begin{matrix} +0.022 \\ +0.013 \end{matrix}$	17	10	0.3	13	4 550	5 100	460	520	19 000	28 000	RNAO-10×17×10T2
		20	12	0.3	16	7 100	5 950	720	610	19 000	28 000	RNAO-10×20×12
12	$\begin{matrix} +0.027 \\ +0.016 \end{matrix}$	19	13.5	0.3	15	6 000	7 700	615	785	17 000	26 000	RNAO-12×19×13.5
		22	12	0.3	18	8 650	8 000	880	815	17 000	26 000	RNAO-12×22×12
14	$\begin{matrix} +0.027 \\ +0.016 \end{matrix}$	22	13	0.3	18	8 300	10 100	845	1 030	16 000	24 000	RNAO-14×22×13
		22	20	0.3	18	11 800	16 000	1 210	1 630	16 000	24 000	RNAO-14×22×20ZW
		26	12	0.3	20	9 350	9 150	955	930	16 000	24 000	RNAO-14×26×12
15	$\begin{matrix} +0.027 \\ +0.016 \end{matrix}$	23	13	0.3	19	8 250	10 200	840	1 040	15 000	23 000	RNAO-15×23×13
		23	20	0.3	19	11 700	16 100	1 200	1 640	15 000	23 000	RNAO-15×23×20ZW
16	$\begin{matrix} +0.027 \\ +0.016 \end{matrix}$	24	13	0.3	20	9 050	11 800	925	1 200	15 000	23 000	RNAO-16×24×13
		24	20	0.3	20	12 900	18 500	1 310	1 890	15 000	23 000	RNAO-16×24×20ZW
		28	12	0.3	22	11 700	12 500	1 190	1 280	15 000	23 000	RNAO-16×28×12
17	$\begin{matrix} +0.027 \\ +0.016 \end{matrix}$	25	13	0.3	21	9 400	12 600	960	1 280	15 000	22 000	RNAO-17×25×13
		25	20	0.3	21	12 800	18 600	1 300	1 900	15 000	22 000	RNAO-17×25×20ZW
		25	26	0.3	21	16 100	25 200	1 640	2 570	15 000	22 000	RNAO-17×25×26ZW
18	$\begin{matrix} +0.027 \\ +0.016 \end{matrix}$	26	13	0.3	22	8 900	11 900	910	1 210	14 000	21 000	RNAO-18×26×13
		26	20	0.3	22	12 700	18 800	1 290	1 910	14 000	21 000	RNAO-18×26×20ZW
		30	12	0.3	24	12 300	13 800	1 250	1 410	14 000	21 000	RNAO-18×30×12
		30	24	0.3	24	21 100	27 700	2 150	2 820	14 000	21 000	RNAO-18×30×24ZW
20	$\begin{matrix} +0.033 \\ +0.020 \end{matrix}$	28	13	0.3	24	10 000	14 300	1 020	1 460	13 000	20 000	RNAO-20×28×13
		28	26	0.3	24	17 100	28 600	1 750	2 910	13 000	20 000	RNAO-20×28×26ZW
		32	12	0.3	26	12 900	15 100	1 320	1 540	13 000	20 000	RNAO-20×32×12

Note 1) Allowable minimum chamfer dimension r .

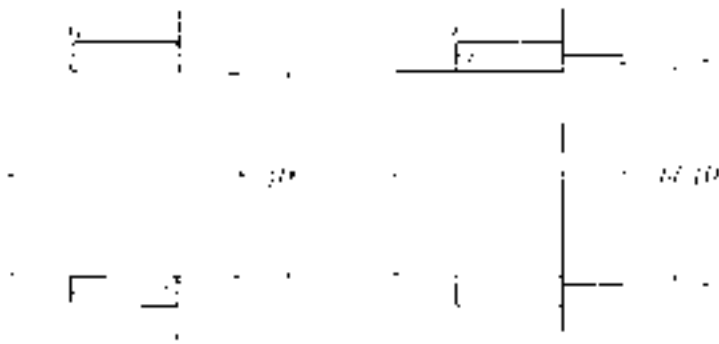

d_b	Abutment dimensions mm			Mass kg (approx.)
	D_a max	D_b	r_{as} max	
7.7	8.8	5.3	0.15	0.003
8.7	11	6.3	0.3	0.006
9.7	12	7.3	0.3	0.006
10.7	13	8.3	0.3	0.008
11.7	14	8.3	0.3	0.017
12.7	15	10.3	0.3	0.010
15.7	18	10.3	0.3	0.018
14.7	17	12.3	0.3	0.015
17.6	20	12.3	0.3	0.019
17.6	20	14.4	0.3	0.018
17.6	20	14.4	0.3	0.027
19.6	24	14.4	0.3	0.029
18.6	21	15.4	0.3	0.020
18.6	21	15.4	0.3	0.031
19.6	22	16.4	0.3	0.021
19.6	22	16.4	0.3	0.032
21.6	26	16.4	0.3	0.032
20.6	23	17.4	0.3	0.022
20.6	23	17.4	0.3	0.034
20.6	23	17.4	0.3	0.044
21.6	24	18.4	0.3	0.022
21.6	24	18.4	0.3	0.033
23.6	28	18.4	0.3	0.035
23.6	28	18.4	0.3	0.069
23.6	26	20.4	0.3	0.025
23.6	26	20.4	0.3	0.050
25.6	30	20.4	0.3	0.038

Without inner ring

Type RNAO
Type RNAO··ZW

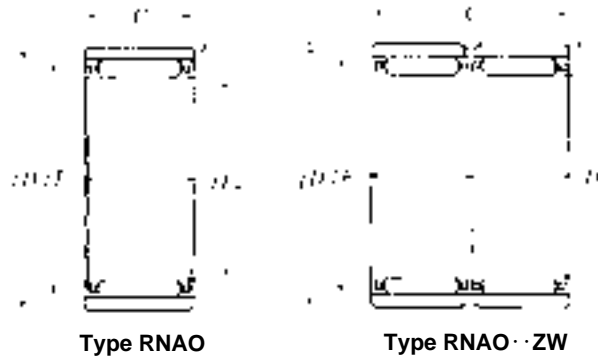

F_w 20~40mm

	Boundary dimensions					Basic load ratings				Limiting speeds		Bearing numbers
	mm					dynamic	static	dynamic	static	r/min		
	F_w	D	C	$r_{s\min}^{1)}$	E	N		kgf		grease	oil	
						C_r	C_{or}	C_r	C_{or}			
20	$\begin{matrix} +0.033 \\ +0.020 \end{matrix}$	32	24	0.3	26	22 100	30 000	2 260	3 100	13 000	20 000	RNAO-20×32×24ZW
22	$\begin{matrix} +0.033 \\ +0.020 \end{matrix}$	30	13	0.3	26	10 200	15 200	1 040	1 550	12 000	18 000	RNAO-22×30×13
		30	26	0.3	26	17 500	30 500	1 790	3 100	12 000	18 000	RNAO-22×30×26ZW
		35	16	0.3	29	18 700	22 700	1 910	2 310	12 000	18 000	RNAO-22×35×16
		35	32	0.3	29	32 000	45 500	3 300	4 650	12 000	18 000	RNAO-22×35×32ZW
25	$\begin{matrix} +0.033 \\ +0.020 \end{matrix}$	35	17	0.3	29	14 200	24 000	1 450	2 450	11 000	16 000	RNAO-25×35×17
		35	26	0.3	29	18 400	33 500	1 880	3 450	11 000	16 000	RNAO-25×35×26ZW
		37	16	0.3	32	19 500	24 700	1 990	2 520	11 000	16 000	RNAO-25×37×16
		37	32	0.3	32	33 500	49 500	3 400	5 050	11 000	16 000	RNAO-25×37×32ZW
26	$\begin{matrix} +0.033 \\ +0.020 \end{matrix}$	39	13	0.3	30	11 800	19 200	1 200	1 960	10 000	15 000	RNAO-26×39×13
28	$\begin{matrix} +0.033 \\ +0.020 \end{matrix}$	40	16	0.3	35	21 200	28 400	2 160	2 900	9 500	14 000	RNAO-28×40×16
		40	32	0.3	35	36 500	57 000	3 700	5 800	9 500	14 000	RNAO-28×40×32ZW
30	$\begin{matrix} +0.033 \\ +0.020 \end{matrix}$	40	17	0.3	35	19 400	32 500	1 970	3 350	9 000	13 000	RNAO-30×40×17
		40	26	0.3	35	25 200	46 000	2 570	4 650	9 000	13 000	RNAO-30×40×26ZW
		42	16	0.3	37	21 900	30 500	2 230	3 100	9 000	13 000	RNAO-30×42×16
		42	32	0.3	37	37 500	60 500	3 850	6 200	9 000	13 000	RNAO-30×42×32ZW
32	$\begin{matrix} +0.041 \\ +0.025 \end{matrix}$	42	13	0.3	37	14 500	23 000	1 480	2 350	8 500	13 000	RNAO-32×42×13
35	$\begin{matrix} +0.041 \\ +0.025 \end{matrix}$	45	13	0.3	40	15 200	25 100	1 550	2 560	7 500	11 000	RNAO-35×45×13
		45	17	0.3	40	20 000	36 000	2 040	3 650	7 500	11 000	RNAO-35×45×17
		45	26	0.3	40	26 100	50 000	2 660	5 100	7 500	11 000	RNAO-35×45×26ZW
		47	16	0.3	42	24 100	36 000	2 450	3 650	7 500	11 000	RNAO-35×47×16
		47	18	0.3	42	24 700	37 000	2 510	3 750	7 500	11 000	RNAO-35×47×18
		47	32	0.3	42	41 500	71 500	4 200	7 300	7 500	11 000	RNAO-35×47×32ZW
37	$\begin{matrix} +0.041 \\ +0.025 \end{matrix}$	47	13	0.3	42	15 900	27 100	1 620	2 770	7 000	11 000	RNAO-37×47×13
		52	18	0.3	44	26 300	41 000	2 680	4 150	7 000	11 000	RNAO-37×52×18
40	$\begin{matrix} +0.041 \\ +0.025 \end{matrix}$	50	17	0.3	45	21 800	41 500	2 220	4 250	6 500	10 000	RNAO-40×50×17
		50	34	0.3	45	37 500	83 000	3 800	8 500	6 500	10 000	RNAO-40×50×34ZW
		55	20	0.3	47	31 000	51 500	3 150	5 250	6 500	10 000	RNAO-40×55×20

Note 1) Allowable minimum chamfer dimension r .

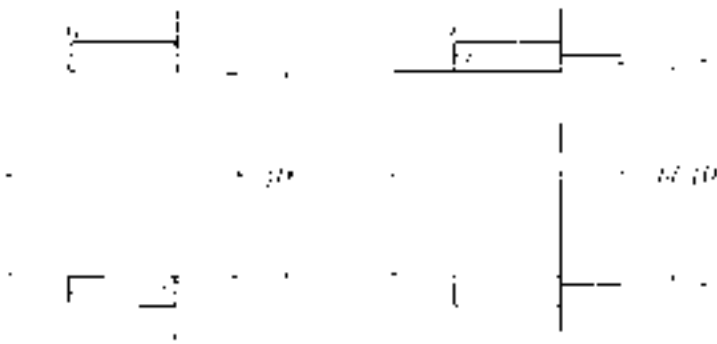

d_b	Abutment dimensions mm			Mass kg (approx.)
	D_a max	D_b	r_{as} max	
25.6	30	20.4	0.3	0.080
25.6	28	22.4	0.3	0.027
25.6	28	22.4	0.3	0.054
28.4	33	22.4	0.3	0.059
28.4	33	22.4	0.3	0.118
28.4	33	25.6	0.3	0.053
28.4	33	25.6	0.3	0.076
31.4	35	25.6	0.3	0.060
31.4	35	25.6	0.3	0.119
29.4	37	26.6	0.3	0.060
34.4	38	28.6	0.3	0.061
34.4	38	28.6	0.3	0.122
34.4	38	30.6	0.3	0.060
34.4	38	30.6	0.3	0.094
36.4	40	30.6	0.3	0.069
36.4	40	30.6	0.3	0.137
36.4	40	32.6	0.3	0.049
39.4	43	35.6	0.3	0.053
39.4	43	35.6	0.3	0.069
39.4	43	35.6	0.3	0.091
41.4	45	35.6	0.3	0.078
41.4	45	35.6	0.3	0.089
41.4	45	35.6	0.3	0.156
41.4	45	37.6	0.3	0.056
43.4	50	37.6	0.3	0.125
44.4	48	40.6	0.3	0.074
44.4	48	40.6	0.3	0.152
46.2	53	40.6	0.3	0.145

Without inner ring

Type RNAO
Type RNAO ·· ZW

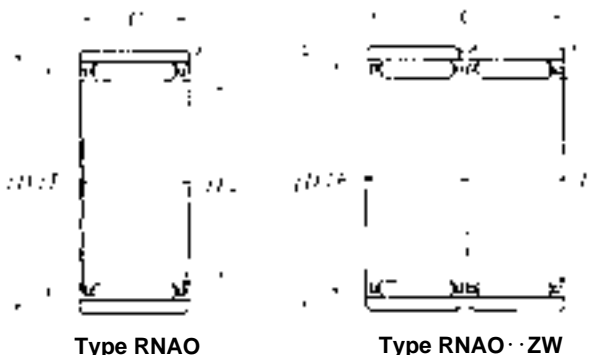

F_w 40~85mm

F_w	Boundary dimensions					Basic load ratings				Limiting speeds		Bearing numbers	
	mm					dynamic	static	dynamic	static	r/min	grease		oil
	D	C	$r_{s \min}^1$	E		N	kgf						
40	+0.041 +0.025	55	40	0.3	48	56 500	102 000	5 750	10 400	6 500	10 000	RNAO-40× 55×40ZW	
45	+0.041 +0.025	55	17	0.3	50	22 300	44 500	2 280	4 550	6 000	9 000	RNAO-45× 55×17	
		55	34	0.3	50	38 500	89 500	3 900	9 100	6 000	9 000	RNAO-45× 55×34ZW	
		62	20	0.3	53	36 000	59 000	3 650	6 000	6 000	9 000	RNAO-45× 62×20	
		62	40	0.3	53	61 500	118 000	6 250	12 000	6 000	9 000	RNAO-45× 62×40ZW	
50	+0.041 +0.025	62	20	0.3	55	27 900	62 000	2 850	6 300	5 500	8 000	RNAO-50× 62×20	
		62	40	0.3	55	48 000	124 000	4 900	12 600	5 500	8 000	RNAO-50× 62×40ZW	
		65	20	0.3	58	38 500	67 500	3 950	6 850	5 500	8 000	RNAO-50× 65×20	
		65	40	0.6	58	66 500	135 000	6 750	13 700	5 500	8 000	RNAO-50× 65×40ZW	
55	+0.049 +0.030	68	20	0.6	60	28 800	66 500	2 940	6 750	4 800	7 500	RNAO-55× 68×20	
		68	25	0.6	63	50 500	97 500	5 150	9 950	4 800	7 500	RNAO-55× 68×25	
		68	40	0.6	60	49 500	133 000	5 050	13 500	4 800	7 500	RNAO-55× 68×40ZW	
		72	20	0.6	63	39 000	70 000	3 950	7 100	4 800	7 500	RNAO-55× 72×20	
		72	40	0.6	63	66 500	140 000	6 800	14 200	4 800	7 500	RNAO-55× 72×40ZW	
60	+0.049 +0.030	75	46	1	68	76 000	170 000	7 750	17 400	4 400	6 500	RNAO-60× 75×46ZW	
		78	20	1	68	40 000	75 000	4 100	7 650	4 400	6 500	RNAO-60× 78×20	
		78	40	1	68	69 000	150 000	7 050	15 300	4 400	6 500	RNAO-60× 78×40ZW	
65	+0.049 +0.030	85	30	1	73	61 000	132 000	6 200	13 400	4 100	6 000	RNAO-65× 85×30	
		85	60	1	73	104 000	263 000	10 600	26 800	4 100	6 000	RNAO-65× 85×60ZW	
70	+0.049 +0.030	90	30	1	78	65 500	149 000	6 700	15 200	3 800	5 500	RNAO-70× 90×30	
		90	60	1	78	112 000	297 000	11 500	30 500	3 800	5 500	RNAO-70× 90×60ZW	
75	+0.049 +0.030	95	30	1	83	67 500	157 000	6 850	16 100	3 600	5 500	RNAO-75× 95×30	
		95	60	1	83	115 000	315 000	11 800	32 000	3 600	5 500	RNAO-75× 95×60ZW	
80	+0.049 +0.030	95	30	1	86	57 000	159 000	5 800	16 200	3 300	5 000	RNAO-80× 95×30	
		95	56	1	88	105 000	284 000	10 700	29 000	3 300	5 000	RNAO-80× 95×56ZW	
		100	30	1	88	69 000	166 000	7 050	17 000	3 300	5 000	RNAO-80×100×30	
		100	60	1	88	119 000	335 000	12 100	34 000	3 300	5 000	RNAO-80×100×60ZW	
85	+0.058 +0.036	105	25	1	93	61 500	146 000	6 250	14 900	3 100	4 700	RNAO-85×105×25	

Note 1) Allowable minimum chamfer dimension r .

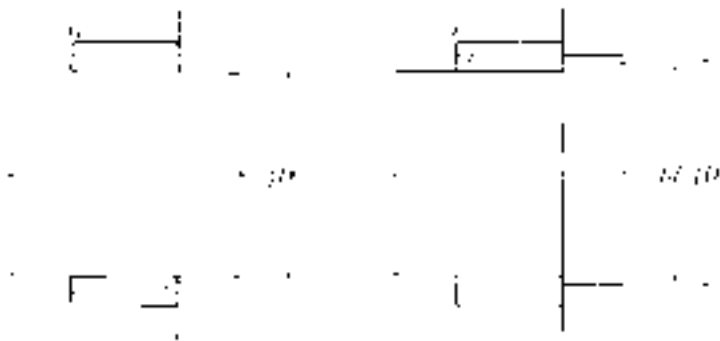

d_b	Abutment dimensions			Mass kg (approx.)
	D_a max	D_b	r_{as} max	
47.2	53	40.6	0.3	0.275
49.2	53	45.6	0.3	0.083
49.2	53	45.6	0.3	0.165
52.2	60	45.6	0.3	0.175
52.2	60	45.6	0.3	0.377
54.2	60	50.6	0.3	0.140
54.2	60	50.6	0.3	0.295
57.2	63	50.6	0.3	0.168
57.2	61	50.6	0.6	0.355
59.4	64	55.8	0.6	0.166
62.4	64	55.8	0.6	0.200
59.4	64	55.8	0.6	0.310
62.4	68	55.8	0.6	0.216
62.4	68	55.8	0.6	0.425
67.2	70	60.8	1	0.461
67.2	73	60.8	1	0.255
67.2	73	60.8	1	0.500
72.2	80	66	1	0.464
72.2	80	66	1	0.951
77.2	85	71	1	0.499
77.2	85	71	1	1.00
82.2	90	76	1	0.520
82.2	90	76	1	1.04
85.2	90	81	1	0.405
87.2	90	81	1	0.755
87.2	95	81	1	0.580
87.2	95	81	1	1.10
92.2	100	86	1	0.459

Without inner ring

Type RNAO

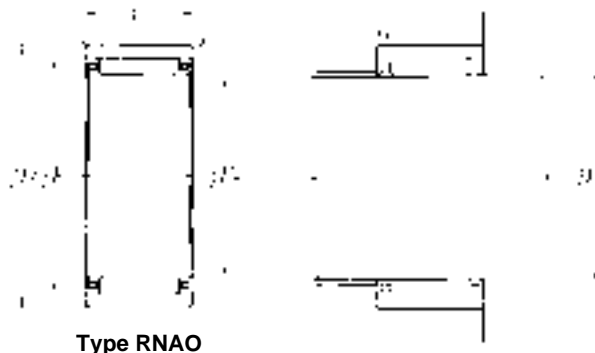

F_w 85~100mm

Boundary dimensions					Basic load ratings				Limiting speeds		Bearing numbers	
mm					dynamic	static	dynamic	static	r/min			
F_w	D	C	$r_s \text{ min}^{1)}$	E	N		kgf		grease	oil		
					C_r	C_{or}	C_r	C_{or}				
85	$\begin{matrix} +0.058 \\ +0.036 \end{matrix}$	105	30	1	93	71 000	175 000	7 200	17 900	3 100	4 700	RNAO- 85×105×30
90	$\begin{matrix} +0.058 \\ +0.036 \end{matrix}$	105	26	1	98	64 000	157 000	6 550	16 000	3 000	4 400	RNAO- 90×105×26
		110	30	1	98	72 500	184 000	7 400	18 800	3 000	4 400	RNAO- 90×110×30
95	$\begin{matrix} +0.058 \\ +0.036 \end{matrix}$	115	30	1	103	74 000	193 000	7 550	19 600	2 800	4 200	RNAO- 95×115×30
100	$\begin{matrix} +0.058 \\ +0.035 \end{matrix}$	120	30	1	108	76 000	201 000	7 700	20 500	2 700	4 000	RNAO-100×120×30

Note 1) Allowable minimum chamfer dimension r_s .

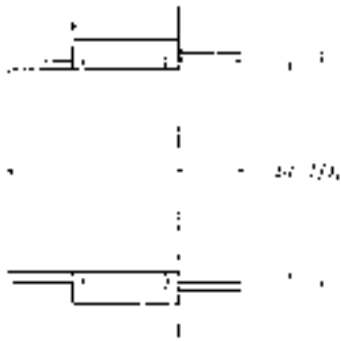

d_b	Abutment dimensions mm			Mass kg (approx.)
	D_a max	D_b	r_{as} max	
92.2	100	86	1	0.585
97.2	100	91	1	0.373
97.2	105	91	1	0.610
102.2	110	96	1	0.640
107.2	115	101	1	0.694

With inner ring

Type NAO
Type NAO··ZW

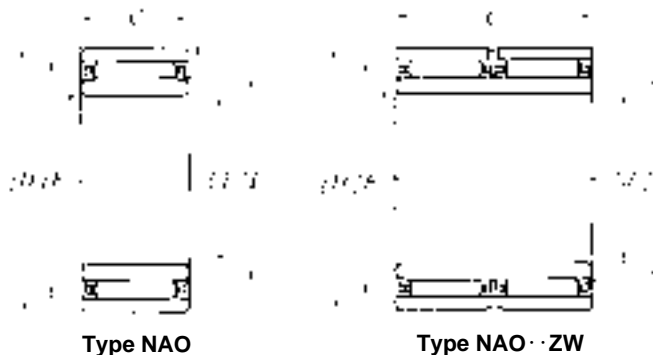

d 6~30mm

Boundary dimensions						Basic load ratings				Limiting speeds		Bearing numbers
mm						dynamic	static	dynamic	static	r/min grease oil		
d	D	C	r _{s min} ¹⁾	F	E	N	N	kgf	kgf			
6	17	10	0.3	10	13	4 550	5 100	460	520	19 000	28 000	NAO- 6×17×10T2
7	20	12	0.3	10	16	7 100	5 950	720	610	19 000	28 000	NAO- 7×20×12
9	22	12	0.3	12	18	8 650	8 000	880	815	17 000	26 000	NAO- 9×22×12
10	22	13	0.3	14	18	8 300	10 100	845	1 030	16 000	24 000	NAO-10×22×13
	22	20	0.3	14	18	11 800	16 000	1 210	1 630	16 000	24 000	NAO-10×22×20ZW
	26	12	0.3	14	20	9 350	9 150	955	930	16 000	24 000	NAO-10×26×12
12	24	13	0.3	16	20	9 050	11 800	925	1 200	15 000	23 000	NAO-12×24×13
	24	20	0.3	16	20	12 900	18 500	1 310	1 890	15 000	23 000	NAO-12×24×20ZW
	28	12	0.3	16	22	11 700	12 500	1 190	1 280	15 000	23 000	NAO-12×28×12
15	28	13	0.3	20	24	10 000	14 300	1 020	1 460	13 000	20 000	NAO-15×28×13
	28	26	0.3	20	24	17 100	28 600	1 750	2 910	13 000	20 000	NAO-15×28×26ZW
	32	12	0.3	20	26	12 900	15 100	1 320	1 540	13 000	20 000	NAO-15×32×12
17	30	13	0.3	22	26	10 200	15 200	1 040	1 550	12 000	18 000	NAO-17×30×13
	30	26	0.3	22	26	17 500	30 500	1 790	3 100	12 000	18 000	NAO-17×30×26ZW
	35	16	0.3	22	29	18 700	22 700	1 910	2 310	12 000	18 000	NAO-17×35×16
	35	32	0.3	22	29	32 000	45 500	3 300	4 650	12 000	18 000	NAO-17×35×32ZW
20	35	17	0.3	25	29	14 200	24 000	1 450	2 450	11 000	16 000	NAO-20×35×17
	35	26	0.3	25	29	18 400	33 500	1 880	3 450	11 000	16 000	NAO-20×35×26ZW
	37	16	0.3	25	32	19 500	24 700	1 990	2 520	11 000	16 000	NAO-20×37×16
	37	32	0.3	25	32	33 500	49 500	3 400	5 050	11 000	16 000	NAO-20×37×32ZW
25	40	17	0.3	30	35	19 400	32 500	1 970	3 350	9 000	13 000	NAO-25×40×17
	40	26	0.3	30	35	25 200	46 000	2 570	4 650	9 000	13 000	NAO-25×40×26ZW
	42	16	0.3	30	37	21 900	30 500	2 230	3 100	9 000	13 000	NAO-25×42×16
	42	32	0.3	30	37	37 500	60 500	3 850	6 200	9 000	13 000	NAO-25×42×32ZW
29	42	13	0.3	32	37	14 500	23 000	1 480	2 350	8 500	13 000	NAO-29×42×13
30	45	13	0.3	35	40	15 200	25 100	1 550	2 560	7 500	11 000	NAO-30×45×13
	45	17	0.3	35	40	20 000	36 000	2 040	3 650	7 500	11 000	NAO-30×45×17
	45	26	0.3	35	40	26 100	50 000	2 660	5 100	7 500	11 000	NAO-30×45×26ZW

Note 1) Allowable minimum chamfer dimension r.

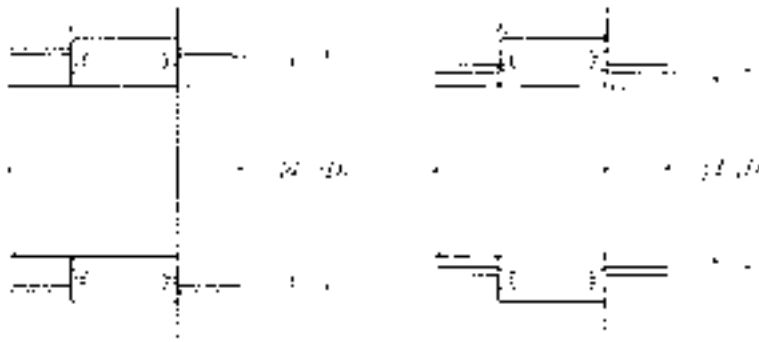

d_a min	d_b	Abutment dimensions mm			r_{as} max	Mass kg (approx.)
		D_a max	D_b			
8	12.7	15	10.3	0.3	0.014	
9	15.7	18	10.3	0.3	0.022	
11	17.6	20	12.3	0.3	0.024	
12	17.6	20	14.4	0.3	0.026	
12	17.6	20	14.4	0.3	0.039	
12	19.6	24	14.4	0.3	0.036	
14	19.6	22	16.4	0.3	0.030	
14	19.6	22	16.4	0.3	0.044	
14	21.6	26	16.4	0.3	0.040	
17	23.6	26	20.4	0.3	0.029	
17	23.6	26	20.4	0.3	0.075	
17	25.6	30	20.4	0.3	0.050	
19	25.6	28	22.4	0.3	0.042	
19	25.6	28	22.4	0.3	0.081	
19	28.4	33	22.4	0.3	0.078	
19	28.4	33	22.4	0.3	0.148	
22	28.4	33	25.6	0.3	0.076	
22	28.4	33	25.6	0.3	0.112	
22	31.4	35	25.6	0.3	0.082	
22	31.4	35	25.6	0.3	0.155	
27	34.4	38	30.6	0.3	0.088	
27	34.4	38	30.6	0.3	0.130	
27	36.4	40	30.6	0.3	0.086	
27	36.4	40	30.6	0.3	0.190	
31	36.4	40	32.6	0.3	0.062	
32	39.4	43	35.6	0.3	0.077	
32	39.4	43	35.6	0.3	0.102	
32	39.4	43	35.6	0.3	0.157	

With inner ring

Type NAO
Type NAO··ZW

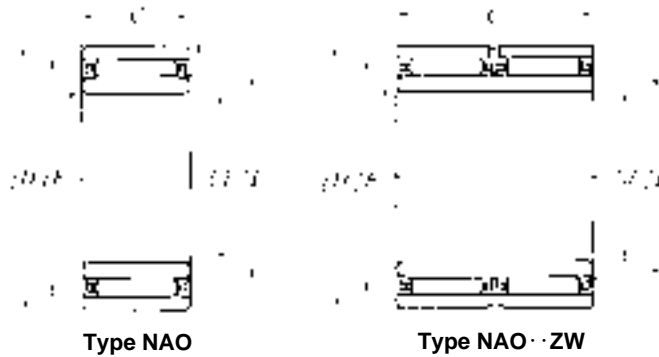

d 30~65mm

Boundary dimensions						Basic load ratings				Limiting speeds		Bearing numbers
mm						dynamic	static	dynamic	static	r/min grease oil		
d	D	C	r _{s min} ¹⁾	F	E	N	N	kgf	kgf			
30	47	16	0.3	35	42	24 100	36 000	2 450	3 650	7 500	11 000	NAO-30×47×16
	47	18	0.3	35	42	24 700	37 000	2 510	3 750	7 500	11 000	NAO-30×47×18
	47	32	0.3	35	42	41 500	71 500	4 200	3 700	7 500	11 000	NAO-30×47×32ZW
	52	18	0.3	37	44	26 300	41 000	2 680	4 150	7 000	11 000	NAO-30×52×18
33	47	13	0.3	37	42	15 900	27 100	1 620	2 770	7 000	11 000	NAO-33×47×13
35	50	17	0.3	40	45	21 800	41 500	2 220	4 250	6 500	10 000	NAO-35×50×17
	50	34	0.3	40	45	37 500	83 000	3 800	8 500	6 500	10 000	NAO-35×50×34ZW
	55	20	0.3	40	47	31 000	51 500	3 150	5 250	6 500	10 000	NAO-35×55×20
	55	40	0.3	40	48	56 500	102 000	5 750	10 400	6 500	10 000	NAO-35×55×40ZW
40	55	17	0.3	45	50	22 300	44 500	2 280	4 550	6 000	9 000	NAO-40×55×17
	55	34	0.3	45	50	38 500	89 500	3 900	9 100	6 000	9 000	NAO-40×55×34ZW
	62	20	0.3	45	53	36 000	59 000	3 650	6 000	6 000	9 000	NAO-40×62×20
	62	40	0.3	45	53	61 500	118 000	6 250	12 000	6 000	9 000	NAO-40×62×40ZW
	65	20	0.3	50	58	38 500	67 500	3 950	6 850	5 500	8 000	NAO-40×65×20
45	62	20	0.3	50	55	27 900	62 000	2 850	6 300	5 500	8 000	NAO-45×62×20
	62	40	0.3	50	55	48 000	124 000	4 900	12 600	5 500	8 000	NAO-45×62×40ZW
	72	20	0.6	55	63	39 000	70 000	3 950	7 100	4 800	7 500	NAO-45×72×20
	72	40	0.6	55	63	66 500	140 000	6 800	14 200	4 800	7 500	NAO-45×72×40ZW
50	68	20	0.6	55	60	28 800	66 500	2 940	6 750	4 800	7 500	NAO-50×68×20
	68	40	0.6	55	60	49 500	133 000	5 050	13 500	4 800	7 500	NAO-50×68×40ZW
	78	20	1	60	68	40 000	75 000	4 100	7 650	4 400	6 500	NAO-50×78×20
	78	40	1	60	68	69 000	150 000	7 050	15 300	4 400	6 500	NAO-50×78×40ZW
55	85	30	1	65	73	61 000	132 000	6 200	13 400	4 100	6 000	NAO-55×85×30
	85	60	1	65	73	104 000	263 000	10 600	26 800	4 100	6 000	NAO-55×85×60ZW
60	90	30	1	70	78	65 500	149 000	6 700	15 200	3 800	5 500	NAO-60×90×30
	90	60	1	70	78	112 000	297 000	11 500	30 500	3 800	5 500	NAO-60×90×60ZW
65	95	30	1	75	83	67 500	157 000	6 850	16 100	3 600	5 500	NAO-65×95×30
	95	60	1	75	83	115 000	315 000	11 800	32 000	3 600	5 500	NAO-65×95×60ZW

Note 1) Allowable minimum chamfer dimension r.

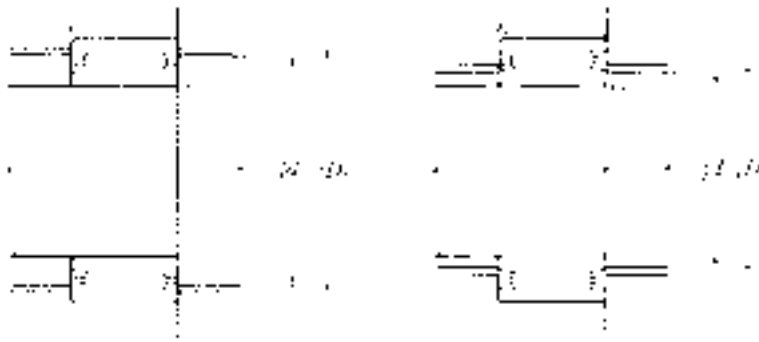

d_a min	d_b	Abutment dimensions mm			r_{as} max	Mass kg (approx.)
		D_a max	D_b			
32	41.4	45	35.6	0.3	0.109	
32	41.4	45	35.6	0.3	0.119	
32	41.4	45	35.6	0.3	0.205	
32	43.4	50	37.6	0.3	0.177	
35	41.4	45	37.6	0.3	0.085	
37	44.4	48	40.6	0.3	0.113	
37	44.4	48	40.6	0.3	0.225	
37	46.2	53	40.6	0.3	0.190	
37	47.2	53	40.6	0.3	0.360	
42	49.2	53	45.6	0.3	0.127	
42	49.2	53	45.6	0.3	0.250	
42	52.2	60	45.6	0.3	0.230	
42	52.2	60	45.6	0.3	0.385	
42	57.2	63	50.6	0.3	0.279	
47	54.2	60	50.6	0.3	0.192	
47	54.2	60	50.6	0.3	0.385	
49	62.4	68	55.8	0.6	0.335	
49	62.4	68	55.8	0.6	0.660	
54	59.4	64	55.8	0.6	0.230	
54	59.4	64	55.8	0.6	0.440	
55	67.2	73	60.8	1	0.410	
55	67.2	73	60.8	1	0.755	
60	72.2	80	66	1	0.680	
60	72.2	80	66	1	1.35	
65	77.2	85	71	1	0.720	
65	77.2	85	71	1	1.45	
70	82.2	90	76	1	0.770	
70	82.2	90	76	1	1.54	

With inner ring

Type NAO
Type NAO··ZW

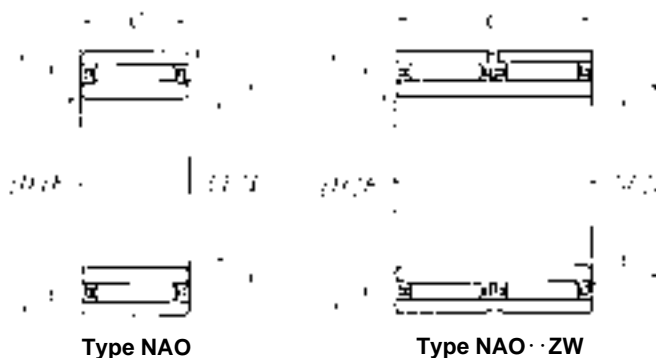

d 70~90mm

Boundary dimensions						Basic load ratings				Limiting speeds		Bearing numbers	
mm						dynamic	static	dynamic	static	r/min	grease		oil
d	D	C	r _{s min} ¹⁾	F	E	N	N	kgf	kgf				
70	95	30	1	80	86	57 000	159 000	5 800	16 200	3 300	5 000	NAO-70× 95×30	
	95	56	1	80	88	105 000	284 000	10 700	29 000	3 300	5 000	NAO-70× 95×56ZW	
	100	30	1	80	88	69 000	166 000	7 050	17 000	3 300	5 000	NAO-70×100×30	
	100	60	1	80	88	119 000	335 000	12 100	34 000	3 300	5 000	NAO-70×100×60ZW	
75	105	25	1	85	93	61 500	146 000	6 250	14 900	3 100	4 700	NAO-75×105×25	
	105	30	1	85	93	71 000	175 000	7 200	17 900	3 100	4 700	NAO-75×105×30	
80	110	30	1	90	98	72 500	184 000	7 400	18 800	3 000	4 400	NAO-80×110×30	
85	115	30	1	95	103	74 000	193 000	7 550	19 600	2 800	4 200	NAO-85×115×30	
90	120	30	1	100	108	76 000	201 000	7 700	20 500	2 700	4 000	NAO-90×120×30	

Note 1) Allowable minimum chamfer dimension r.

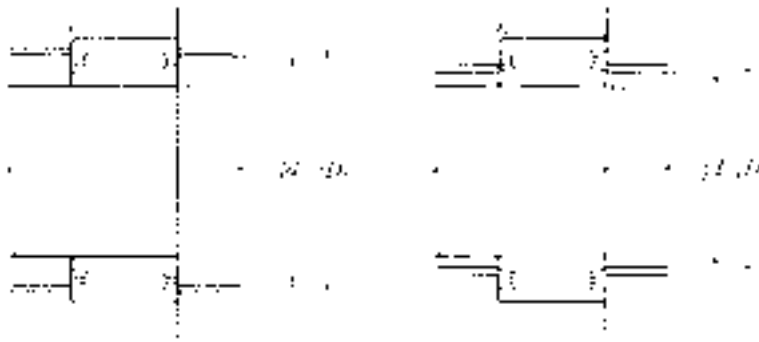

d_a min	d_b	Abutment dimensions mm			r_{as} max	Mass kg (approx.)
		D_a max	D_b			
75	85.2	90	81	1	0.675	
75	87.2	90	81	1	1.26	
75	87.2	95	81	1	0.850	
75	87.2	95	81	1	1.70	
80	92.2	100	86	1	0.700	
80	92.2	100	86	1	0.880	
85	97.2	105	91	1	0.920	
90	102.2	110	96	1	0.960	
95	107.2	115	101	1	1.04	

Inner Rings

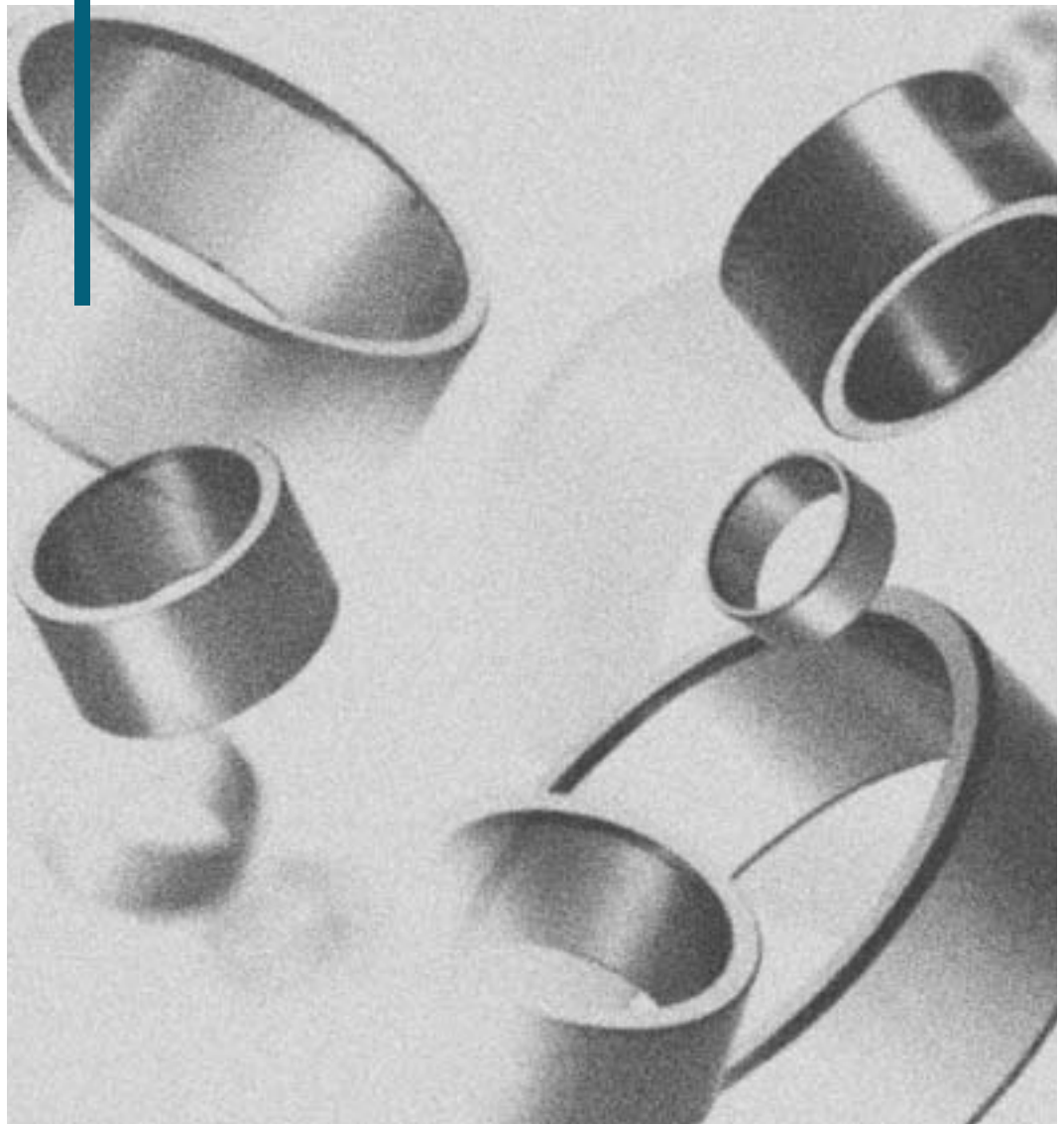

Inner Rings

Inner Rings

Many of the needle roller bearings use a shaft as the direct raceway surface without using inner ring. However, it is recommended to use any of the inner rings described hereunder, together with needle roller bearing, where applicable shaft can not be surface-hardened and surface-finished by grinding. Any inner rings are made of high carbon chrome bearing steel and finished by grinding after heat-treated.

It is desirable to use an inner ring of wide width, where the axial displacement of a shaft is great and also a seal is used at the outer side of bearing.

Types and Designs

NTN inner rings are available in both of **IR type** with boundary dimensions of metric system and **MI type** with boundary dimensions of inch system. The both ends of inner ring raceway are chamfered in taper form to facilitate fitting of the inner ring. On the other hand, any inner rings with an asterisk ※-mark are fine-chamfered so as to allow greater axial displacement. In addition to these inner rings, manufacture of special inner ring type (with tail code: **D**) with oil hole on its center is also available.

Particularly where high running accuracy is required, on occasion the raceway surface of inner ring is finished by grinding after fitted on a shaft. In such a case, an inner ring with grinding allowance for its raceway can be supplied. Feel free to contact **NTN** for the detail of such an inner ring.

Composition of nominal number

Nominal number comprises type code (**IR** or **MI**), dimension code [bore dia. (d) \times raceway dia. (F) \times width (B)] and tail code.

The dimension of inch series **MI** type is expressed at the unit of 1/16 inch.

Dimensional accuracy for inner ring

The dimensional accuracy (bore diameter " d ", width " B " and chamfer dimension " r_s min"), profile accuracy and running accuracy of the inner rings are as shown in **Tables 4.3** and 4.5 of Section 4 "**Bearing accuracy**" (page A-26). And the standard accuracy class of these items conforms to JIS Class-0, but other inner rings conforming to JIS Class-5 and -4 are also offerable on request.

For the dimensional tolerance for raceway diameter (F) shown in applicable Dimension Table, the inner ring is finished so the radial clearance comes to ordinary clearance (refer to **Table 5.1** of 5.2 "**Running clearance**" (page A-30) when it is combined with needle rollers.

Feel free to contact **NTN** for use of an inner ring subjected to radial clearance other than ordinary clearance.

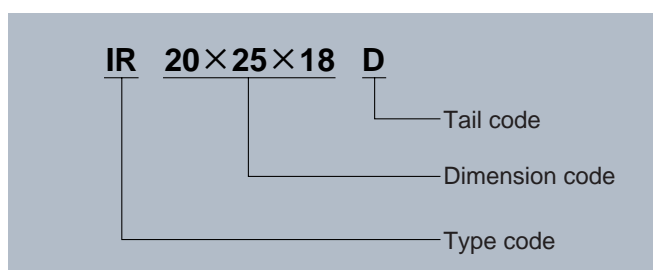
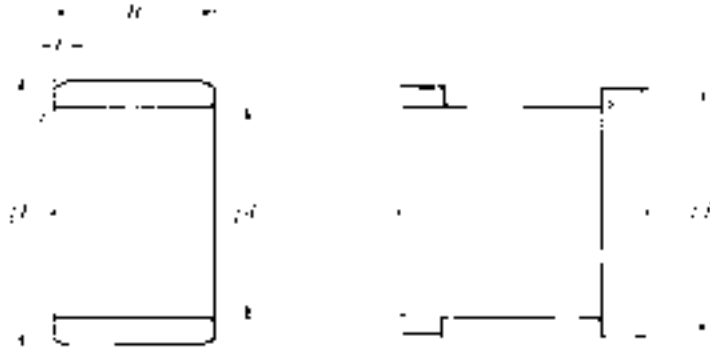

Fig. 1

Type IR



d 5~10mm

Boundary dimensions					Bearing numbers	Abutment dimensions		Mass kg (approx.)
mm						mm		
d	$F^{1)}$	B	$r_s \text{ min}^{2)}$	t		d_a min	r_{as} max	
5	7	10	0.15	1	IR 5×7×10	6.2	0.15	0.0014
	8 ⁰ _{-0.006}	12	0.3	1	IR 5×8×12	7	0.3	0.0028
	8	16	0.3	—	※IR 5×8×16	7	0.3	0.0038
6	8	10	0.15	1	IR 6×8×10	7.2	0.15	0.0017
	9	12	0.3	1	IR 6×9×12	8	0.3	0.0032
	9 ⁰ _{-0.006}	16	0.3	1	IR 6×9×16	8	0.3	0.0043
	10 ⁰ _{-0.006}	10	0.3	1	IR 6×10×10	8	0.3	0.0037
	10	12	0.3	—	※IR 6×10×12D	8	0.3	0.0046
	10	13	0.3	1	IR 6×10×13	8	0.3	0.0050
7	9	10	0.15	1	IR 7×9×10	8.2	0.15	0.0019
	10 ⁰ _{-0.006}	10.5	0.3	1	IR 7×10×10.5	9	0.3	0.0031
	10 ⁰ _{-0.006}	12	0.3	1	IR 7×10×12	9	0.3	0.0036
	10	16	0.3	1	IR 7×10×16	9	0.3	0.0049
	12 ⁻⁰ _{-0.008}	16	0.3	1	IR 7×12×16	9	0.3	0.0093
8	10 ⁰ _{-0.006}	11	0.15	1	IR 8×10×11	9.2	0.15	0.0024
	12 ⁰ _{-0.006}	10	0.3	1	IR 8×12×10	10	0.3	0.0048
	12	10.5	0.3	1	IR 8×12×10.5	10	0.3	0.0050
	12 ⁰ _{-0.008}	12	0.3	—	※IR 8×12×12D	10	0.3	0.0057
	12	12.5	0.3	1	IR 8×12×12.5	10	0.3	0.0059
	14	16	0.3	1	IR 8×14×16	10	0.3	0.013
9	12	11	0.3	1	IR 9×12×11	11	0.3	0.0041
	12 ⁰ _{-0.008}	12	0.3	1	IR 9×12×12	11	0.3	0.0045
	12 ⁰ _{-0.008}	16	0.3	1	IR 9×12×16	11	0.3	0.0061
	15	16	0.3	1	IR 9×15×16	11	0.3	0.014
10	13	12.5	0.3	1	IR10×13×12.5	12	0.3	0.0052
	14	12	0.3	1	IR10×14×12	12	0.3	0.0073
	14 ⁰ _{-0.008}	13	0.3	1	IR10×14×13	12	0.3	0.0074
	14 ⁰ _{-0.008}	14	0.3	—	※IR10×14×14D	12	0.3	0.0080
	14	16	0.3	—	※IR10×14×16	12	0.3	0.0092
	14	20	0.3	1	IR10×14×20	12	0.3	0.012

Note 1) Dimensional tolerance to secure ordinary clearance when any of these inner rings is combined with needle roller bearing with no inner ring.

2) Allowable minimum chamfer dimension r .

Remarks: 1. Nominal number plus code "D" represents inner ring with oil hole.

2. Nominal number plus ※-mark represents inner ring with fine-chamfered outer surface.

Type IR

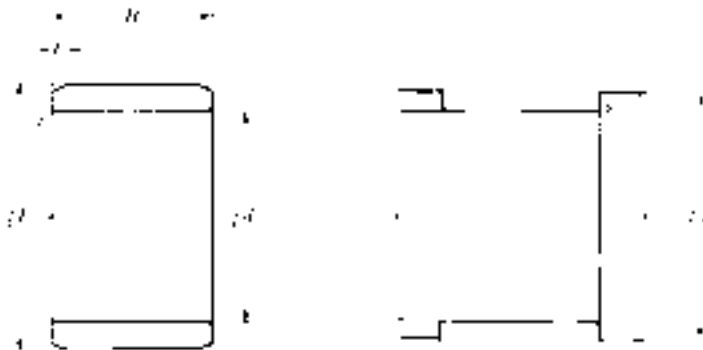

d 10~15mm

Boundary dimensions					Bearing numbers	Abutment dimensions		Mass kg (approx.)
mm						mm		
d	$F^{1)}$	B	$r_s \text{ min}^{2)}$	t		d_a min	r_{as} max	
10	15	15.5	0.3	1	IR10×15×15.5	12	0.3	0.012
	15 ⁰ _{-0.008}	20.5	0.3	1	IR10×15×20.5	12	0.3	0.015
	16	16	0.3	1	IR10×16×16	12	0.3	0.015
12	15	12	0.3	1	IR12×15×12	14	0.3	0.0058
	15	12.5	0.3	1	IR12×15×12.5	14	0.3	0.0061
	15	16	0.3	1	IR12×15×16	14	0.3	0.0078
	15	16.5	0.3	—	※ IR12×15×16.5	14	0.3	0.0080
	15	22.5	0.3	—	※ IR12×15×22.5	14	0.3	0.011
	16	12	0.3	1.5	IR12×16×12	14	0.3	0.0079
	16 ⁰ _{-0.008}	13	0.3	1.5	IR12×16×13	14	0.3	0.0087
	16	14	0.3	—	※ IR12×16×14D	14	0.3	0.0095
	16	16	0.3	1.5	IR12×16×16	14	0.3	0.011
	16	20	0.3	1.5	IR12×16×20	14	0.3	0.014
	16	22	0.3	1.5	IR12×16×22	14	0.3	0.015
	17	20.5	0.3	1.5	IR12×17×20.5	14	0.3	0.019
	17	25.5	0.3	1.5	IR12×17×25.5	14	0.3	0.024
18	16	0.3	1.5	IR12×18×16	14	0.3	0.018	
14	17 ⁰ _{-0.008}	17	0.3	1.5	IR14×17×17	16	0.3	0.0095
15	18	12.5	0.3	1.5	IR15×18×12.5	17	0.3	0.0072
	18	16	0.3	1.5	IR15×18×16	17	0.3	0.0093
	18 ⁰ _{-0.008}	16.5	0.3	1.5	IR15×18×16.5	17	0.3	0.0096
	18	17.5	0.3	1.5	IR15×18×17.5	17	0.3	0.010
	18	20.5	0.3	1.5	IR15×18×20.5	17	0.3	0.012
	18	25.5	0.3	1.5	IR15×18×25.5	17	0.3	0.015
	19	16	0.3	1.5	IR15×19×16	17	0.3	0.013
	19	20	0.3	1.5	IR15×19×20	17	0.3	0.016
	20	12	0.3	1.5	IR15×20×12	17	0.3	0.012
	20 ⁰ _{-0.009}	13	0.3	1.5	IR15×20×13	17	0.3	0.014
	20	14	0.3	—	※ IR15×20×14D	17	0.3	0.015
	20	18	0.3	1.5	IR15×20×18	17	0.3	0.019
	20	20.5	0.3	1.5	IR15×20×20.5	17	0.3	0.021

Note 1) Dimensional tolerance to secure ordinary clearance when any of these inner rings is combined with needle roller bearing with no inner ring.

2) Allowable minimum chamfer dimension r .

Remarks: 1. Nominal number plus code "D" represents inner ring with oil hole.

2. Nominal number plus ※-mark represents inner ring with fine-chamfered outer surface.

d 15~20mm

Boundary dimensions					Bearing numbers	Abutment dimensions		Mass kg (approx.)
mm						mm		
d	$F^{1)}$	B	$r_s \text{ min}^{2)}$	t	d_a min	r_{as} max		
15	20	23	0.3	—	※IR15×20×23	17	0.3	0.024
	20	26	0.3	1.5	IR15×20×26	17	0.3	0.027
	20 _{-0.009} ⁰	30.5	0.3	1.5	IR15×20×30.5	17	0.3	0.032
	22	20	0.6	1.5	IR15×22×20	19	0.6	0.032
17	20	16	0.3	1.5	IR17×20×16	19	0.3	0.011
	20	16.5	0.3	1.5	IR17×20×16.5	19	0.3	0.011
	20	20	0.3	1.5	IR17×20×20	19	0.3	0.014
	20	20.5	0.3	—	※IR17×20×20.5	19	0.3	0.014
	20	30.5	0.3	—	※IR17×20×30.5	19	0.3	0.021
	21	16	0.3	1.5	IR17×21×16	19	0.3	0.014
	21	20	0.3	—	※IR17×21×20	19	0.3	0.018
	22	13	0.3	1.5	IR17×22×13	19	0.3	0.015
	22 _{-0.009} ⁰	14	0.3	—	※IR17×22×14D	19	0.3	0.016
	22	16	0.3	—	※IR17×22×16	19	0.3	0.019
	22	18	0.3	1.5	IR17×22×18	19	0.3	0.021
	22	20.5	0.3	1.5	IR17×22×20.5	19	0.3	0.024
	22	23	0.3	—	※IR17×22×23	19	0.3	0.027
	22	26	0.3	1.5	IR17×22×26	19	0.3	0.030
	22	32	0.3	1.5	IR17×22×32	19	0.3	0.036
	24	20	0.6	1.5	IR17×24×20	21	0.6	0.034
20	24	16	0.3	1.8	IR20×24×16	22	0.3	0.017
	24	20	0.3	—	※IR20×24×20	22	0.3	0.021
	24	28.5	0.3	—	※IR20×24×28.5	22	0.3	0.030
	25	12.5	0.3	1.8	IR20×25×12.5	22	0.3	0.016
	25	16	0.3	—	※IR20×25×16	22	0.3	0.021
	25 _{-0.009} ⁰	16.5	0.3	1.8	IR20×25×16.5	22	0.3	0.022
	25	17	0.3	1.8	IR20×25×17	22	0.3	0.022
	25	18	0.3	—	※IR20×25×18D	22	0.3	0.024
	25	20	0.3	—	※IR20×25×20	22	0.3	0.027
	25	20.5	0.3	1.8	IR20×25×20.5	22	0.3	0.028
	25	23	0.3	1.8	IR20×25×23	22	0.3	0.031

Note 1) Dimensional tolerance to secure ordinary clearance when any of these inner rings is combined with needle roller bearing with no inner ring.

2) Allowable minimum chamfer dimension r .

Remarks: 1. Nominal number plus code "D" represents inner ring with oil hole.

2. Nominal number plus ※-mark represents inner ring with fine-chamfered outer surface.

Type IR

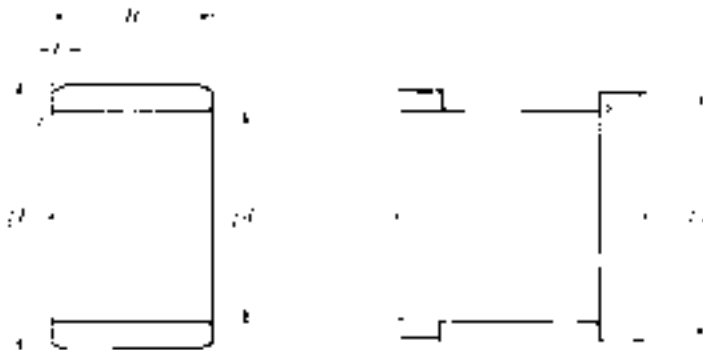

d 20~28mm

Boundary dimensions					Bearing numbers	Abutment dimensions		Mass kg (approx.)
mm						mm		
d	$F^{1)}$	B	$r_{s \min}^{2)}$	t		d_a min	r_{as} max	
20	25	26	0.3	1.8	IR20×25×26	22	0.3	0.034
	25	26.5	0.3	—	※IR20×25×26.5	22	0.3	0.036
	25 ₀	30	0.3	1.8	IR20×25×30	22	0.3	0.041
	25 _{-0.009}	32	0.3	1.8	IR20×25×32	22	0.3	0.041
	25	38.5	0.3	—	※IR20×25×38.5	22	0.3	0.053
	28	20	0.6	1.8	IR20×28×20	24	0.6	0.045
22	26	16	0.3	1.8	IR22×26×16	24	0.3	0.017
	26	20	0.3	—	※IR22×26×20	24	0.3	0.022
	28	17	0.3	1.8	IR22×28×17	24	0.3	0.030
	28 ₀	20	0.3	1.8	IR22×28×20	24	0.3	0.035
	28 _{-0.009}	20.5	0.3	1.8	IR22×28×20.5	24	0.3	0.036
	28	23	0.3	1.8	IR22×28×23	24	0.3	0.042
	28	30	0.3	—	※IR22×28×30	24	0.3	0.054
25	29	20	0.3	—	※IR25×29×20	27	0.3	0.026
	29	30	0.3	1.8	IR25×29×30	27	0.3	0.039
	30	12.5	0.3	1.8	IR25×30×12.5	27	0.3	0.020
	30	16	0.3	1	IR25×30×16	27	0.3	0.024
	30	16.5	0.3	1.8	IR25×30×16.5	27	0.3	0.026
	30	17	0.3	1.8	IR25×30×17	27	0.3	0.027
	30	18	0.3	—	※IR25×30×18	27	0.3	0.030
	30 ₀	20	0.3	1.8	IR25×30×20	27	0.3	0.033
	30 _{-0.009}	20.5	0.3	1.8	IR25×30×20.5	27	0.3	0.034
	30	23	0.3	1.8	IR25×30×23	27	0.3	0.038
	30	26	0.3	1.8	IR25×30×26	27	0.3	0.041
	30	26.5	0.3	—	※IR25×30×26.5	27	0.3	0.043
	30	30	0.3	1.8	IR25×30×30	27	0.3	0.050
	30	32	0.3	1	IR25×30×32	27	0.3	0.054
	30	38.5	0.3	—	※IR25×30×38.5	27	0.3	0.064
32 _{+0.008}	22	0.6	1.8	IR25×32×22	29	0.6	0.052	
32 _{-0.002}	30.5	0.6	1.8	IR25×32×30.5	29	0.6	0.072	
28	32 _{-0.008} _{-0.002}	17	0.3	1.8	IR28×32×17	30	0.3	0.025

Note 1) Dimensional tolerance to secure ordinary clearance when any of these inner rings is combined with needle roller bearing with no inner ring.

2) Allowable minimum chamfer dimension r .

Remarks: 1. Nominal number plus ※-mark represents inner ring with fine-chamfered outer surface.

d 28~35mm

Boundary dimensions					Bearing numbers	Abutment dimensions		Mass kg (approx.)
mm						mm		
<i>d</i>	<i>F</i> ¹⁾	<i>B</i>	<i>r</i> 's min ²⁾	<i>t</i>	<i>d</i> _a min	<i>r</i> _{as} max		
28	32	20	0.3	1.8	IR28×32×20	30	0.3	0.028
	32 ^{+0.008 -0.002}	23	0.3	1.8	IR28×32×23	30	0.3	0.034
	32	30	0.3	—	※ IR28×32×30	30	0.3	0.044
29	32 ^{+0.008 -0.002}	13	0.3	1.8	IR29×32×13	31	0.3	0.015
30	35	12.5	0.3	1.8	IR30×35×12.5	32	0.3	0.024
	35	13	0.3	1.3	IR30×35×13	32	0.3	0.025
	35	16	0.3	—	※ IR30×35×16	32	0.3	0.031
	35	16.5	0.3	1.8	IR30×35×16.5	32	0.3	0.032
	35	17	0.3	1.8	IR30×35×17	32	0.3	0.032
	35	18	0.3	—	※ IR30×35×18D	32	0.3	0.035
	35	20	0.3	—	※ IR30×35×20	32	0.3	0.038
	35 ^{+0.008 -0.002}	20.5	0.3	1.8	IR30×35×20.5	32	0.3	0.039
	35	23	0.3	1.8	IR30×35×23	32	0.3	0.044
	35	26	0.3	1.8	IR30×35×26	32	0.3	0.050
	35	30	0.3	—	※ IR30×35×30	32	0.3	0.059
	35	32	0.3	1.8	IR30×35×32	32	0.3	0.063
	37	18	0.3	1.8	IR30×37×18	32	0.3	0.050
	37	22	0.6	1.8	IR30×37×22	34	0.6	0.061
38	20	0.6	—	※ IR30×38×20	34	0.6	0.065	
32	37	20	0.3	2	IR32×37×20	34	0.3	0.040
	37	30	0.3	—	※ IR32×37×30	34	0.3	0.063
	38 ₀	32	0.3	2	IR32×38×32	34	0.3	0.082
	40 ^{-0.011}	20	0.6	2	IR32×40×20	36	0.6	0.068
	40	27	0.6	2	IR32×40×27	36	0.6	0.092
	40	36	0.6	2	IR32×40×36	36	0.6	0.124
33	37 ₀ ^{-0.011}	13	0.3	2	IR33×37×13	35	0.3	0.022
35	40	12.5	0.3	2	IR35×40×12.5	37	0.3	0.027
	40 ₀ ^{-0.011}	16.5	0.3	2	IR35×40×16.5	37	0.3	0.037
	40	17	0.3	2	IR35×40×17	37	0.3	0.038
	40	20	0.3	2	IR35×40×20	37	0.3	0.044

Note 1) Dimensional tolerance to secure ordinary clearance when any of these inner rings is combined with needle roller bearing with no inner ring.

2) Allowable minimum chamfer dimension *r*'.

Remarks: 1. Nominal number plus code "D" represents inner ring with oil hole.

2. Nominal number plus ※-mark represents inner ring with fine-chamfered outer surface.

Type IR

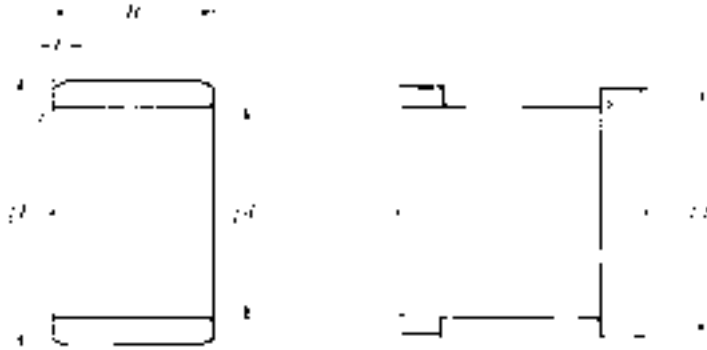

d 35~45mm

Boundary dimensions					Bearing numbers	Abutment dimensions		Mass kg (approx.)
mm						mm		
<i>d</i>	<i>F</i> ¹⁾	<i>B</i>	<i>r</i> _{s min} ²⁾	<i>t</i>		<i>d</i> _a min	<i>r</i> _{as} max	
35	40	20.5	0.3	2	IR35×40×20.5	37	0.3	0.046
	40	30	0.3	—	※IR35×40×30	37	0.3	0.068
	40	34	0.3	1.8	IR35×40×34	37	0.3	0.079
	40	40	0.3	2	IR35×40×40	37	0.3	0.091
	42 ₀ ^{-0.011}	20	0.6	1.8	IR35×42×20	39	0.6	0.064
	42	21	0.6	—	※IR35×42×21	39	0.6	0.068
	42	23	0.6	—	※IR35×42×23D	39	0.6	0.074
	42	27	0.6	2	IR35×42×27	39	0.6	0.080
	42	36	0.6	2	IR35×42×36	39	0.6	0.117
43	22	0.6	2	IR35×43×22	39	0.6	0.081	
38	43 ₀ ^{-0.011}	20	0.3	1.8	IR38×43×20	40	0.3	0.048
	43	30	0.3	—	※IR38×43×30	40	0.3	0.074
40	45	16.5	0.3	2	IR40×45×16.5	42	0.3	0.042
	45	17	0.3	2	IR40×45×17	42	0.3	0.043
	45	20	0.3	2	IR40×45×20	42	0.3	0.051
	45	20.5	0.3	2	IR40×45×20.5	42	0.3	0.053
	45	26.5	0.3	—	※IR40×45×26.5	42	0.3	0.068
	45	30	0.3	2	IR40×45×30	42	0.3	0.077
	45 ₀ ^{-0.011}	34	0.3	2	IR40×45×34	42	0.3	0.088
	45	40	0.3	2	IR40×45×40	42	0.3	0.106
	48	22	0.6	2	IR40×48×22	44	0.6	0.092
	48	23	0.6	—	※IR40×48×23	44	0.6	0.097
	48	30	0.6	2	IR40×48×30	44	0.6	0.123
	48	40	0.6	2	IR40×48×40	44	0.6	0.170
50	20	0.3	0.8	IR40×50×20	44	0.3	0.106	
50	22	1	2	IR40×50×22	45	1	0.118	
42	47 ₀ ^{-0.011}	20	0.3	2	IR42×47×20	44	0.3	0.053
	47	30	0.3	2	IR42×47×30	44	0.3	0.080
45	50 ₀ ^{-0.011}	20	0.3	2	IR45×50×20	47	0.3	0.057
	50	25	0.6	2	IR45×50×25	49	0.6	0.071

Note 1) Dimensional tolerance to secure ordinary clearance when any of these inner rings is combined with needle roller bearing with no inner ring.

2) Allowable minimum chamfer dimension *r*.

Remarks: 1. Nominal number plus code "D" represents inner ring with oil hole.

2. Nominal number plus ※-mark represents inner ring with fine-chamfered outer surface.

d 45~55mm

Boundary dimensions					Bearing numbers	Abutment dimensions		Mass kg (approx.)
mm						mm		
<i>d</i>	<i>F</i> ¹⁾	<i>B</i>	<i>r</i> 's min ²⁾	<i>t</i>	<i>d</i> _a min	<i>r</i> _{as} max		
45	50	25.5	0.3	—	※IR45×50×25.5	47	0.3	0.074
	50	32	0.6	—	※IR45×50×32	49	0.6	0.092
	50							
	50	35	0.6	2	IR45×50×35	49	0.6	0.101
	50	40	0.3	1.5	IR45×50×40	47	0.3	0.115
	52	22	0.6	2	IR45×52×22	49	0.6	0.088
	52	23	0.6	—	※IR45×52×23D	49	0.6	0.093
	52	30	0.6	2	IR45×52×30	49	0.6	0.123
	52	40	0.6	2	IR45×52×40	49	0.6	0.164
	52							
55	20	0.6	2	IR45×55×20	49	0.6	0.116	
55	22	1	2	IR45×55×22	50	1	0.130	
55	40	0.6	2	IR45×55×40	49	0.6	0.173	
50	55	20	0.6	2	IR50×55×20	54	0.6	0.063
	55	25	0.6	2	IR50×55×25	54	0.6	0.078
	55	35	0.6	2	IR50×55×35	54	0.6	0.112
	55	40	0.6	2	IR50×55×40	54	0.6	0.128
	58	22	0.6	2	IR50×58×22	54	0.6	0.113
	58	23	0.6	—	※IR50×58×23D	54	0.6	0.119
	58							
	58	30	0.6	2	IR50×58×30	54	0.6	0.159
	58	40	0.6	2	IR50×58×40	54	0.6	0.209
	60	20	1	2	IR50×60×20	55	1	0.129
	60	25	1	2	IR50×60×25	55	1	0.163
60	28	1.1	2	IR50×60×28	56.5	1	0.183	
60	40	1	2	IR50×60×40	55	1	0.262	
55	60	25	0.6	2.2	IR55×60×25	59	0.6	0.086
	60	35	0.6	2	IR55×60×35	59	0.6	0.121
	63	25	1	2	IR55×63×25	60	1	0.141
	63	34	1	2.2	IR55×63×34	60	1	0.192
	63							
	63	45	1	2.2	IR55×63×45	60	1	0.256
	65	28	1.1	2.2	IR55×65×28	61.5	1	0.206
	65	30	1	2.2	IR55×65×30	60	1	0.220
65	60	1	1.5	IR55×65×60	60	1	0.440	

Note 1) Dimensional tolerance to secure ordinary clearance when any of these inner rings is combined with needle roller bearing with no inner ring.

2) Allowable minimum chamfer dimension *r*'.

Remarks: 1. Nominal number plus code "D" represents inner ring with oil hole.

2. Nominal number plus ※-mark represents inner ring with fine-chamfered outer surface.

Type IR

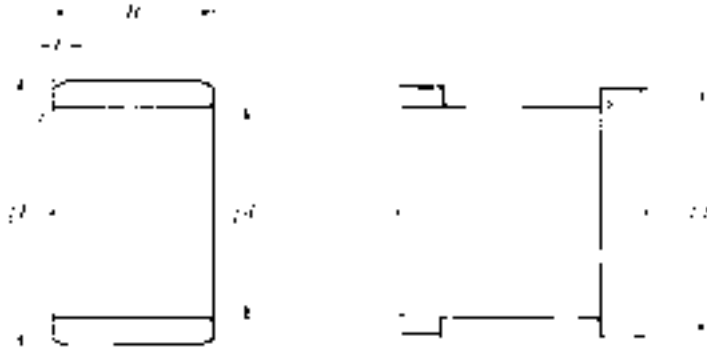

d 60~75mm

Boundary dimensions					Bearing numbers	Abutment dimensions		Mass kg (approx.)
mm						mm		
<i>d</i>	<i>F</i> ¹⁾	<i>B</i>	<i>r</i> _{s min} ²⁾	<i>t</i>	<i>d</i> _a min	<i>r</i> _{as} max		
60	68	25	1	2.2	IR60×68×25	65	1	0.152
	68	34	1	2.2	IR60×68×34	65	1	0.206
	68	35	0.6	2.2	IR60×68×35	64	0.6	0.213
	68 ₀ ^{-0.013}	45	1	2.2	IR60×68×45	65	1	0.270
	70	25	1	2.2	IR60×70×25	65	1	0.195
	70	28	1.1	2.2	IR60×70×28	66.5	1	0.216
	70	30	1	2.2	IR60×70×30	65	1	0.232
	70	60	1	2.2	IR60×70×60	65	1	0.463
65	72	25	1	2.2	IR65×72×25	70	1	0.142
	72	34	1	2.2	IR65×72×34	70	1	0.193
	72	45	1	2.2	IR65×72×45	70	1	0.259
	73 ₀ ^{-0.013}	25	0.6	2.2	IR65×73×25	69	0.6	0.164
	73	35	0.6	2.2	IR65×73×35	69	0.6	0.232
	75	28	1.1	2.2	IR65×75×28	71.5	1	0.240
	75	30	1	2.2	IR65×75×30	70	1	0.256
	75	60	1	2.2	IR65×75×60	70	1	0.513
70	80	25	1	2.2	IR70×80×25	75	1	0.224
	80	28	1.1	2.2	IR70×80×28	76.5	1	0.250
	80	30	1	2.2	IR70×80×30	75	1	0.267
	80 ₀ ^{-0.013}	35	1	2.2	IR70×80×35	75	1	0.313
	80	40	1	2.2	IR70×80×40	75	1	0.358
	80	54	1	2.2	IR70×80×54	75	1	0.483
	80	56	1	2.2	IR70×80×56	75	1	0.502
	80	60	1	2.2	IR70×80×60	75	1	0.540
75	85	25	1	2.2	IR75×85×25	80	1	0.238
	85	30	1	2.2	IR75×85×30	80	1	0.287
	85 ₀ ^{-0.015}	35	1	2.2	IR75×85×35	80	1	0.336
	85	40	1	2.2	IR75×85×40	80	1	0.385
	85	54	1	2.2	IR75×85×54	80	1	0.515
	90	32	1.1	2.2	IR75×90×32	81.5	1	0.480

Note 1) Dimensional tolerance to secure ordinary clearance when any of these inner rings is combined with needle roller bearing with no inner ring.
 2) Allowable minimum chamfer dimension *r*.

d 80~100mm

Boundary dimensions					Bearing numbers	Abutment dimensions		Mass kg (approx.)
mm						mm		
<i>d</i>	<i>F</i> ¹⁾	<i>B</i>	<i>r</i> 's min ²⁾	<i>t</i>	<i>d</i> _a min	<i>r</i> _{as} max		
80	90	25	1	2.2	IR 80×90×25	85	1	0.254
	90	30	1	2.2	IR 80×90×30	85	1	0.304
	90	35	1	2.2	IR 80×90×35	85	1	0.355
	90	40	1	2.2	IR 80×90×40	85	1	0.408
	90	54	1	2.2	IR 80×90×54	85	1	0.543
	95	32	1.1	2.2	IR 80×95×32	86.5	1	0.510
85	95	26	1	2.5	IR 85×95×26	90	1	0.280
	95	30	1	2.5	IR 85×95×30	90	1	0.323
	95	36	1	2.5	IR 85×95×36	90	1	0.398
	100	32	1.1	2.5	IR 85×100×32	91.5	1	0.530
	100	35	1.1	2.5	IR 85×100×35	91.5	1	0.580
	100	46	1.1	2.5	IR 85×100×46	91.5	1	0.760
	100	63	1.1	2.5	IR 85×100×63	91.5	1	1.05
90	100	26	1	2.5	IR 90×100×26	95	1	0.294
	100	30	1	2.5	IR 90×100×30	95	1	0.340
	100	36	1	2.5	IR 90×100×36	95	1	0.406
	105	32	1.1	2.5	IR 90×105×32	96.5	1	0.560
	105	35	1.1	2.5	IR 90×105×35	96.5	1	0.610
	105	46	1.1	2.5	IR 90×105×46	96.5	1	0.800
	105	63	1.1	2.5	IR 90×105×63	96.5	1	1.11
95	105	26	1	2.5	IR 95×105×26	100	1	0.313
	105	36	1	2.5	IR 95×105×36	100	1	0.430
	110	32	1.1	2.5	IR 95×110×32	101.5	1	0.590
	110	35	1.1	2.5	IR 95×110×35	101.5	1	0.640
	110	46	1.1	2.5	IR 95×110×46	101.5	1	0.850
	110	63	1.1	2.5	IR 95×110×63	101.5	1	1.17
100	110	30	1.1	2.5	IR100×110×30	106.5	1	0.375
	110	40	1.1	2.5	IR100×110×40	106.5	1	0.505
	115	32	1.1	2.5	IR100×115×32	106.5	1	0.620
	115	40	1.1	2.5	IR100×115×40	106.5	1	0.775

Note 1) Dimensional tolerance to secure ordinary clearance when any of these inner rings is combined with needle roller bearing with no inner ring.
 2) Allowable minimum chamfer dimension *r*'.

Type IR

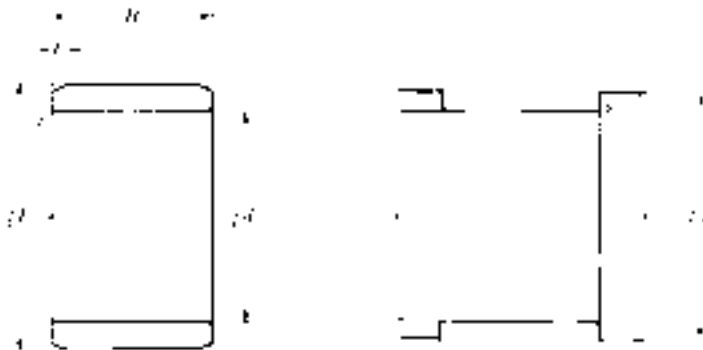

d 100~160mm

Boundary dimensions					Bearing numbers	Abutment dimensions		Mass kg (approx.)
mm						mm		
d	$F^{1)}$	B	$r_{s\ min}^{2)}$	t	d_a min	r_{as} max		
100	115 ⁰ _{-0.015}	54	1.1	2.5	IR100×115×54	106.5	1	1.09
	120 ⁰ _{-0.015}	30	1	2.5		IR110×120×30	115	1
110	120 ⁰ _{-0.015}	40	1.1	2.5	IR110×120×40	116.5	1	0.580
	125 ⁰ _{-0.018}	40	1.1	2.5	IR110×125×40	116.5	1	0.840
	125 ⁰ _{-0.018}	54	1.1	2.5	IR110×125×54	116.5	1	1.16
120	130	30	1	2.2	IR120×130×30	125	1	0.440
	130	40	1.1	2.5	IR120×130×40	126.5	1	0.590
	135 ⁰ _{-0.018}	40	2	2.5	IR120×135×40	129	2	0.870
	135	45	1.1	2.5	IR120×135×45	126.5	1	0.980
	135	60	1.1	2.5	IR120×135×60	126.5	1	1.25
130	145	32	1.5	3	IR130×145×32	138	1.5	0.780
	145	35	1.1	3	IR130×145×35	136.5	1	0.855
	145 ⁰ _{-0.018}	42	1.5	3	IR130×145×42	138	1.5	1.05
	150 ⁰ _{-0.018}	50	1.5	3	IR130×150×50	138	1.5	1.69
	150	52	2	3	IR130×150×52	139	2	1.75
	150	67	1.5	3	IR130×150×67	138	1.5	2.25
140	155	32	1.5	3	IR140×155×32	148	1.5	0.840
	155	35	1.1	3	IR140×155×35	146.5	1	0.917
	155 ⁰ _{-0.018}	42	1.5	3	IR140×155×42	148	1.5	1.10
	160 ⁰ _{-0.018}	50	1.5	3	IR140×160×50	148	1.5	1.70
	160	52	2	3	IR140×160×52	149	2	1.78
	160	67	1.5	3	IR140×160×67	148	1.5	2.30
150	165	32	1.5	3	IR150×165×32	158	1.5	0.900
	165	40	1.1	3	IR150×165×40	156.5	1	1.12
	165 ^{-0.017} _{-0.035}	42	1.5	3	IR150×165×42	158	1.5	1.18
	170	52	2	3	IR150×170×52	159	2	2.00
	170	60	2	3	IR150×170×60	159	2	2.35
160	175 ^{-0.017} _{-0.035}	40	1.1	3	IR160×175×40	166.5	1	1.20
	180 ^{-0.017} _{-0.035}	60	2	3	IR160×180×60	169	2	2.50

Note 1) Dimensional tolerance to secure ordinary clearance when any of these inner rings is combined with needle roller bearing with no inner ring.
 2) Allowable minimum chamfer dimension r' .

d 170~380mm

Boundary dimensions					Bearing numbers	Abutment dimensions		Mass kg (approx.)
mm						mm		
<i>d</i>	<i>F</i> ¹⁾	<i>B</i>	<i>r</i> 's min ²⁾	<i>t</i>	<i>d</i> _a min	<i>r</i> _{as} max		
170	185 _{-0.013}	45	1.1	3	IR170×185× 45	176.5	1	1.45
	190 _{-0.043}	60	2	3	IR170×190× 60	179	2	2.65
180	195 _{-0.013}	45	1.1	3	IR180×195× 45	186.5	1	1.51
	205 _{-0.043}	69	2	3	IR180×205× 69	189	2	4.10
190	210 _{-0.020}	50	1.5	3.5	IR190×210× 50	198	1.5	2.41
	215 _{-0.050}	69	2	3.5	IR190×215× 69	199	2	4.10
200	220 _{-0.020}	50	1.5	3.5	IR200×220× 50	208	1.5	2.49
	225 _{-0.050}	80	2.1	3.5	IR200×225× 80	211	2	5.10
220	240 _{-0.033}	50	1.5	3.5	IR220×240× 50	228	1.5	2.75
	245 _{-0.063}	80	2.1	3.5	IR220×245× 80	231	2	5.70
240	265 _{-0.037}	60	2	3.5	IR240×265× 60	249	2	4.60
	265 _{-0.069}	80	2.1	3.5	IR240×265× 80	251	2	6.30
260	285 _{-0.064}	60	2	4	IR260×285× 60	269	2	4.98
	290 _{-0.092}	100	2.1	4	IR260×290×100	271	2	10.0
280	305 _{-0.064}	69	2	4	IR280×305× 69	289	2	6.20
	310 _{-0.092}	100	2.1	4	IR280×310×100	291	2	10.8
300	330 _{-0.062}	80	2.1	4	IR300×330× 80	311	2	9.30
	340 _{-0.098}	118	3	4	IR300×340×118	313	2.5	18.5
320	350 _{-0.062}	80	2.1	5	IR320×350× 80	331	2	9.80
	360 _{-0.098}	118	3	5	IR320×360×118	333	2.5	20.0
340	370 _{-0.062}	80	2.1	5	IR340×370× 80	351	2	10.1
	380 _{-0.098}	118	3	5	IR340×380×118	353	2.5	22.0
360	390 _{-0.090}	80	2.1	5	IR360×390× 80	371	2	10.9
	400 _{-0.126}	118	3	5	IR360×400×118	373	2.5	22.0
380	415 _{-0.080}	100	2.1	5	IR380×415×100	391	2	18.5
	430 _{-0.120}	140	4	5	IR380×430×140	396	3	35.0

Note 1) Dimensional tolerance to secure ordinary clearance when any of these inner rings is combined with needle roller bearing with no inner ring.
 2) Allowable minimum chamfer dimension *r*'.

Type IR

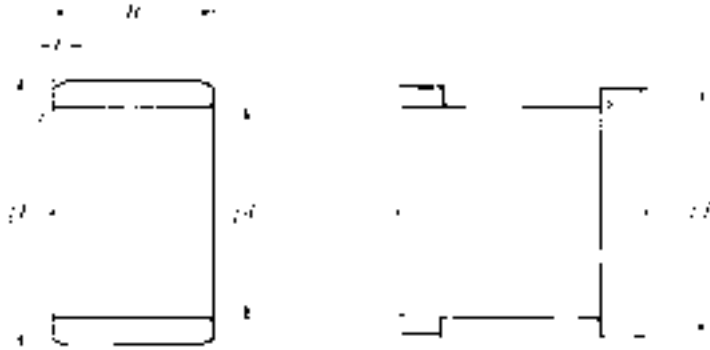

d 400~440mm

Boundary dimensions					Bearing numbers	Abutment dimensions		Mass kg (approx.)
mm						mm		
d	$F^{1)}$	B	$r_{s \min}^{2)}$	t		d_a min	r_{as} max	
400	450 -0.080 -0.120	140	4	5	IR400×450×140	416	3	36.5
420	470 -0.105 -0.145	140	4	5	IR420×470×140	436	3	38.2
440	490 -0.105 -0.145	160	4	5	IR440×490×160	456	3	46.5

Note 1) Dimensional tolerance to secure ordinary clearance when any of these inner rings is combined with needle roller bearing with no inner ring.
 2) Allowable minimum chamfer dimension r .

Inch series

Type MI

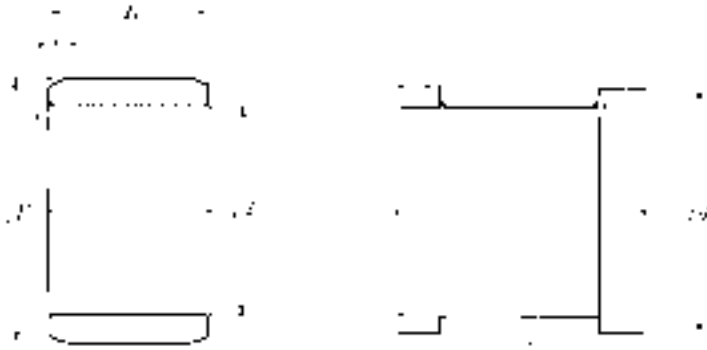

d z9.525~34.925mm

Boundary dimensions						Bearing numbers	Abutment dimensions		Mass kg (approx.)
mm ($\frac{1}{25.4}$ mm)							d_a	r_{as}	
d	$F^{1)}$	B	r_s min ²⁾	t		min	max		
9.525($\frac{3}{8}$)	14.288($\frac{9}{16}$)	12.95	0.6	—	※MI-060908	13.5	0.6	0.013	
	15.875($\frac{5}{8}$) 0 -0.008	19.30	0.6	1	MI-061012	13.5	0.6	0.019	
	15.875($\frac{5}{8}$)	25.65	0.6	1	MI-061016	13.5	0.6	0.025	
12.700($\frac{1}{2}$)	19.050($\frac{3}{4}$)	16.13	1	—	※MI-081210	17.5	1	0.020	
	19.050($\frac{3}{4}$) 0 -0.009	19.30	1	—	※MI-081212	17.5	1	0.024	
	19.050($\frac{3}{4}$)	25.65	1	—	※MI-081216	17.5	1	0.032	
15.875($\frac{5}{8}$)	22.225($\frac{7}{8}$)	9.78	1	—	※MI-101406	21	1	0.014	
	22.225($\frac{7}{8}$)	12.95	1	—	※MI-101408	21	1	0.018	
	22.225($\frac{7}{8}$) 0 -0.009	19.30	1	—	※MI-101412	21	1	0.027	
	22.225($\frac{7}{8}$)	25.65	1	—	※MI-101416	21	1	0.036	
19.050($\frac{3}{4}$)	25.400(1)	19.30	1	—	※MI-121612	24	1	0.034	
	25.400(1) 0 -0.009	25.65	1	—	※MI-121616	24	1	0.045	
22.225($\frac{7}{8}$)	28.575($1\frac{1}{8}$)	12.95	1	—	※MI-141808	27	1	0.027	
	28.575($1\frac{1}{8}$)	19.30	1	—	※MI-141812	27	1	0.040	
	28.575($1\frac{1}{8}$) 0 -0.009	25.65	1	—	※MI-141816	27	1	0.052	
	28.575($1\frac{1}{8}$)	32.00	1	—	※MI-141820	27	1	0.066	
25.400(1)	31.750($1\frac{1}{4}$)	19.30	1	—	※MI-162012	30.5	1	0.039	
	31.750($1\frac{1}{4}$) +0.008 -0.002	25.65	1	—	※MI-162016	30.5	1	0.052	
	31.750($1\frac{1}{4}$)	32.00	1	—	※MI-162020	30.5	1	0.065	
28.575($1\frac{1}{8}$)	34.925($1\frac{3}{8}$)	12.95	1	—	※MI-182208	33.5	1	0.032	
	34.925($1\frac{3}{8}$) +0.008 -0.002	25.65	1	—	※MI-182216	33.5	1	0.063	
	34.925($1\frac{3}{8}$)	32.00	1	—	※MI-182220	33.5	1	0.079	
31.750($1\frac{1}{4}$)	38.100($1\frac{1}{2}$)	25.65	1.5	—	※MI-202416	37	1.5	0.075	
	38.100($1\frac{1}{2}$) 0 -0.011	32.00	1.5	—	※MI-202420	37	1.5	0.094	
33.338($1\frac{5}{16}$)	41.275($1\frac{5}{8}$)	25.65	1.5	2	MI-212616	40	1.5	0.093	
	41.275($1\frac{5}{8}$) 0 -0.011	32.00	1.5	2	MI-212620	40	1.5	0.116	
34.925($1\frac{3}{8}$)	41.275($1\frac{5}{8}$)	16.13	1.5	2	MI-222610	40	1.5	0.073	
	44.450($1\frac{3}{4}$) 0 -0.011	25.65	1.5	2	MI-222816	41.5	1.5	0.117	

Note 1) Dimensional tolerance to secure ordinary clearance when any of these inner rings is combined with needle roller bearing with no inner ring.

2) Allowable minimum chamfer dimension r .

Remarks: 1. Nominal number plus ※-mark represents inner ring with fine-chamfered outer surface. r

Inch series

Type MI

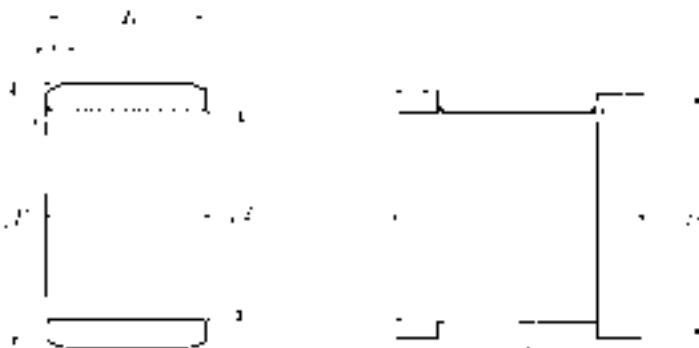

d 34.925~98.425mm

Boundary dimensions					Bearing numbers	Abutment dimensions		Mass kg (approx.)
mm ($\frac{1}{25.4}$ mm)						d_a min	r_{as} max	
d	$F^{1)}$	B	r_s min ²⁾	t				
34.925(1 $\frac{3}{8}$)	44.450(1 $\frac{3}{4}$) -0.011	32.00	1.5	2	MI-222820	41.5	1.5	0.146
38.100(1 $\frac{1}{2}$)	44.450(1 $\frac{3}{4}$) 0	19.30	1.5	2	MI-242812	43	1.5	0.062
	44.450(1 $\frac{3}{4}$) -0.011	25.65	1.5	2	MI-242816	43	1.5	0.083
39.688(1 $\frac{5}{16}$)	47.625(1 $\frac{7}{8}$) -0.011	32.00	1.5	2	MI-253020	46	1.5	0.136
41.275(1 $\frac{5}{8}$)	50.800(2) +0.008	25.65	1.5	2	MI-263216	48	1.5	0.140
	50.800(2) -0.004	32.00	1.5	2	MI-263220	48	1.5	0.175
44.450(1 $\frac{3}{4}$)	57.150(2 $\frac{1}{4}$) +0.008	38.35	1.5	2	MI-283624	51	1.5	0.310
	57.150(2 $\frac{1}{4}$) -0.004	44.70	1.5	2	MI-283628	51	1.5	0.360
50.800(2)	63.500(2 $\frac{1}{2}$) 0	38.35	2	2	MI-324024	59	2	0.340
	63.500(2 $\frac{1}{2}$) -0.013	44.70	2	2	MI-324028	59	2	0.420
57.150(2 $\frac{1}{4}$)	69.850(2 $\frac{3}{4}$)	25.65	2	2.2	MI-364416	65	2	0.257
	69.850(2 $\frac{3}{4}$) -0.013	38.35	2	2.2	MI-364424	65	2	0.384
	69.850(2 $\frac{3}{4}$)	44.70	2	2.2	MI-364428	65	2	0.447
63.500(2 $\frac{1}{2}$)	76.200(3) 0	38.35	2	2.2	MI-404824	71.5	2	0.417
	76.200(3) -0.013	44.70	2	2.2	MI-404828	71.5	2	0.486
66.675(2 $\frac{5}{8}$)	82.550(3 $\frac{1}{4}$) 0	44.70	2	2.2	MI-425228	74.5	2	0.648
	82.550(3 $\frac{1}{4}$) -0.015	51.05	2	2.2	MI-425232	74.5	2	0.740
69.850(2 $\frac{3}{4}$)	82.550(3 $\frac{1}{4}$) -0.015	44.70	2	2.2	MI-445228	78	2	0.530
76.200(3)	88.900(3 $\frac{1}{2}$) 0	44.70	2	2.2	MI-485628	84	2	0.574
	88.900(3 $\frac{1}{2}$) -0.015	51.05	2	2.2	MI-485632	84	2	0.655
79.375(3 $\frac{1}{8}$)	95.250(3 $\frac{3}{4}$) -0.015	51.05	2.5	2.2	MI-506032	88.5	2.5	0.862
85.725(3 $\frac{3}{8}$)	101.600(4) -0.015	51.05	2.5	2.5	MI-546432	94.5	2.5	0.930
92.075(3 $\frac{5}{8}$)	107.950(4 $\frac{1}{4}$) -0.015	51.05	2.5	2.5	MI-586832	101	2.5	1.00
95.250(3 $\frac{3}{4}$)	114.300(4 $\frac{1}{2}$) -0.015	57.40	2.5	2.5	MI-607236	104	2.5	1.40
98.425(3 $\frac{7}{8}$)	114.300(4 $\frac{1}{2}$) 0	57.40	2.5	2.5	MI-627236	107.5	2.5	1.15
	114.300(4 $\frac{1}{2}$) -0.015	63.88	2.5	2.5	MI-627240	107.5	2.5	1.28

Note 1) Dimensional tolerance to secure ordinary clearance when any of these inner rings is combined with needle roller bearing with no inner ring.

2) Allowable minimum chamfer dimension r .

d 101.600~203.200mm

Boundary dimensions					Bearing numbers	Abutment dimensions		Mass kg (approx.)
mm ($\frac{1}{25.4}$ mm)						mm		
d	F ¹⁾	B	r _{s min} ²⁾	t	d _a min	r _{as} max		
101.600(4)	127.000(5)	51.05	2.5	2.5	MI-648032	110.5	2.5	1.82
	127.000(5) $_{-0.018}^0$	57.40	2.5	2.5	MI-648036	110.5	2.5	2.05
	127.000(5)	63.88	2.5	2.5	MI-648040	110.5	2.5	2.28
114.300(4 1/2)	139.700(5 1/2) $_{-0.018}^0$	63.88	2.5	2.5	MI-728840	123.5	2.5	2.58
	139.700(5 1/2)	76.58	2.5	2.5	MI-728848	123.5	2.5	3.10
120.650(4 3/4)	146.050(5 3/4) $_{-0.018}^0$	76.58	3	3	MI-769248	132	3	3.18
127.000(5)	152.400(6) $_{-0.018}^0$	63.88	3	3	MI-809640	140	3	2.80
	152.400(6)	76.58	3	3	MI-809648	140	3	3.35
139.700(5 1/2)	165.100(6 1/2) $_{-0.028}^{-0.010}$	63.88	3	3	MI-8810440	152.5	3	2.84
	165.100(6 1/2)	76.58	3	3	MI-8810448	152.5	3	3.40
152.400(6)	184.150(7 1/4) $_{-0.033}^{-0.013}$	76.58	3	3	MI-9611648	165.5	3	4.80
165.100(6 1/2)	196.850(7 3/4) $_{-0.043}^{-0.013}$	76.58	3	3	MI-10412448	178	3	5.30
177.800(7)	209.550(8 1/4) $_{-0.043}^{-0.013}$	76.58	3	3	MI-11213248	191	3	5.60
190.500(7 1/2)	222.250(8 3/4) $_{-0.050}^{-0.020}$	76.58	4	3	MI-12014048	206.5	4	6.10
203.200(8)	234.950(9 1/4) $_{-0.063}^{-0.033}$	76.58	4	3.5	MI-12814848	219	4	6.50

Note 1) Dimensional tolerance to secure ordinary clearance when any of these inner rings is combined with needle roller bearing with no inner ring.
 2) Allowable minimum chamfer dimension r.

Adjustable-Clearance Needle Roller Bearings

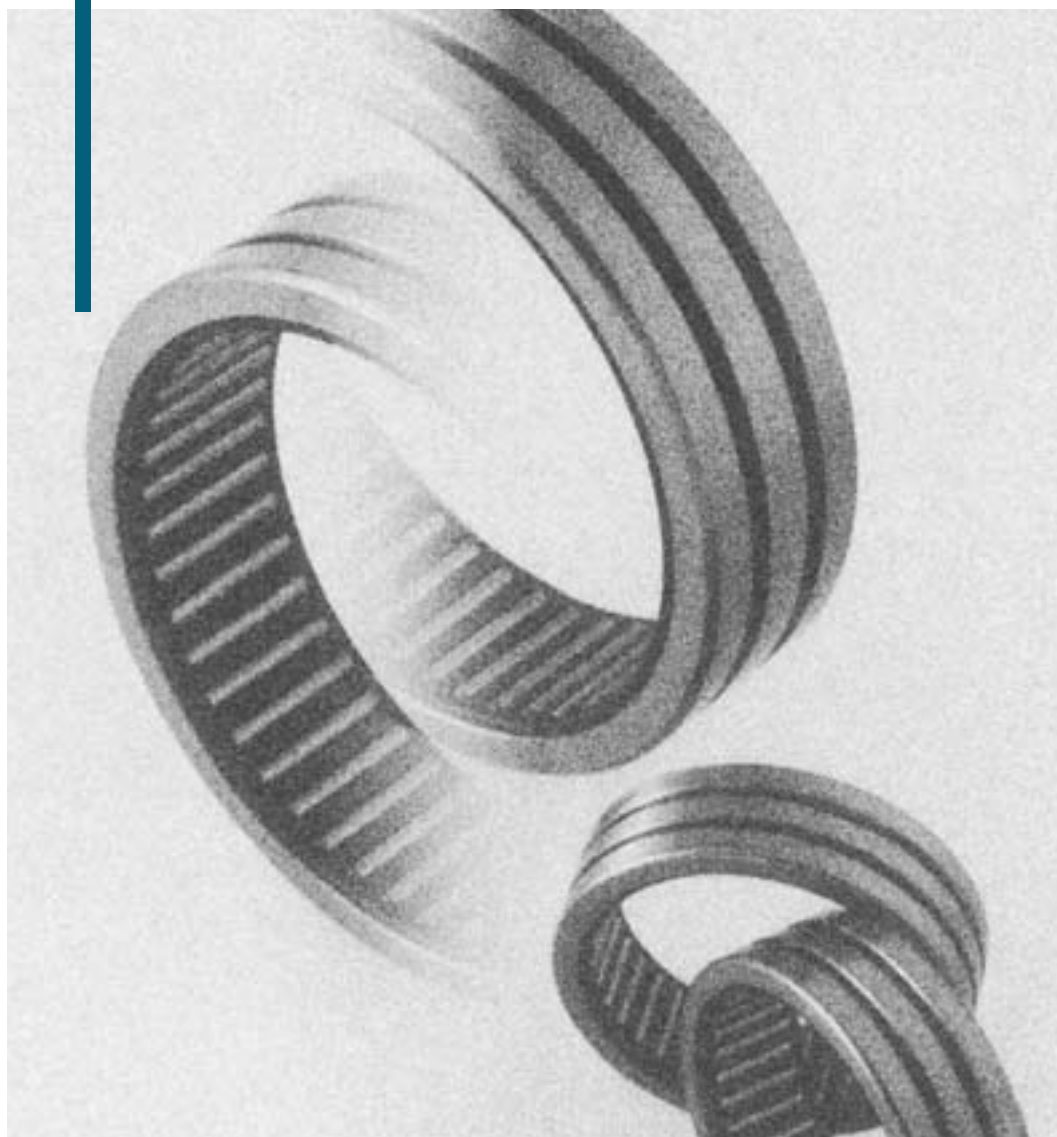

Clearance-Adjustable Needle Roller Bearings

This bearing type comprises a solid outer ring with special machined section and needle rollers and cage built in the outer ring. The outer ring, needle rollers and cage are inseparable from each other. The raceway diameter of the outer ring is shrunk and the roller inscribed circle diameter (F_w) is reduced correspondingly by pressing the outer ring in axial direction.

The radial clearance is fine-adjustable by an load to be applied to the bearing in axial direction, that is, axial shrinkage of the outer ring. This bearing type is mainly applied to the work spindle of a machine tool etc. which require high running accuracy, whose accuracy class is JIS Class-4.

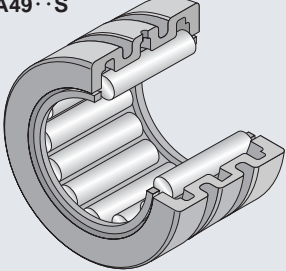
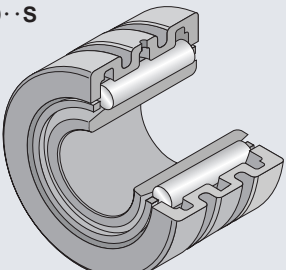
Bearing type	Applied shaft diameter (mm)	Composition of nominal bearing number	Remarks
<p>Type RNA49·S</p> 	$\phi 30 \sim \phi 125$	<p>RNA 49 05 S</p> <ul style="list-style-type: none"> — Type code — Dimension series — Bore diameter number — Tail code 	<p>The dimensional accuracy, profile accuracy and running accuracy conform to JIS Class-4 so as to be available for applications requiring high running accuracy.</p> <p>Another inner ring type with grinding allowance for its raceway surface can also be supplied upon request.</p>
<p>Type NA49·S</p> 	$\phi 25 \sim \phi 110$	<p>[Tail code] S: Clearance-adjustable type</p>	

Bearing accuracy

Application of this bearing type is limited to the portions of a machine which require high running accuracy. Therefore, the dimensional accuracy, profile accuracy and running accuracy of this bearing type conform to JIS Class-4. Higher running accuracy can be achieved by finishing the inner ring raceway surface with grinding allowance by grinding, after the inner ring was press-fitted on a shaft. Feel free to contact NTN for the more detailed information.

Radial clearance and bearing fits

The Type **NA49·S** with inner ring has a radial clearance smaller than the specific ordinary clearance, while the radial clearance of Type **RNA49·S** without inner ring is determined by shaft diameter being selected per applicable "Dimensions Table" which specifies the dimensional tolerances for the roller inscribed circle diameter (F_w).

The outer ring must be fitted in a housing by "close fit" or "tight fit" (interference of approximately $5 \mu\text{m}$) to shrink the raceway diameter by pressing the outer ring in axial direction.

Bearing fit on a shaft and in a housing shall be per **Table 1**.

Table 1 Bearing fit in shaft and housing

Bearing type	Shaft	Housing
RNA49·S	m5	K4
NA49·S	k5	

Shaft and housing accuracy

This bearing type which is applied to the portions of a machine requiring high running accuracy is clamped with the outer ring inclination in installing restrained as less as possible. Therefore, the profile accuracy of the shaft and the housing must be made higher than that for general machined ring needle roller bearings. (**Table 2**)

Table 2 Shaft and housing accuracy

Characteristics	Shaft	Housing
Roundness (max)	IT2	IT3
Cylindricity (max)	IT2	IT3
Shoulder perpendicularity (max)	IT3	IT3

How to adjust radial clearance

The ratio of outer ring axial shrinkage to shrinkage of roller inscribed circle diameter (F_w) is nearly 3:1. In other words, the outer ring must be tightened by 3 mm in axial direction to make the radial clearance smaller by 1 mm.

For adjustment of the radial clearance, the outer ring must be tightened uniformly in parallel to the shaft center. In the case of adjustment by the method illustrated in **Fig.1**, a specific axial tightening value can be obtained by changing the thickness of a spacer, which was inserted between the housing and the lid, by lapping the spacer or replacing it with another spacer. In the case of adjustment by the method illustrated in **Fig.2**, the fixed ring 2 is fitted in the housing and, thereafter, the threaded lid 1 is screwed in until it comes in contact with the outer ring for zero setting. Then, the threaded lid 1 is further screwed in by the required value, after the fixed ring was loosened, and thereafter the fixed ring 2 is retightened. Further, it is recommended to use a saw-toothed tightening screw as illustrated in **Fig. 3** because accuracy-down can be minimized by use of such a screw.

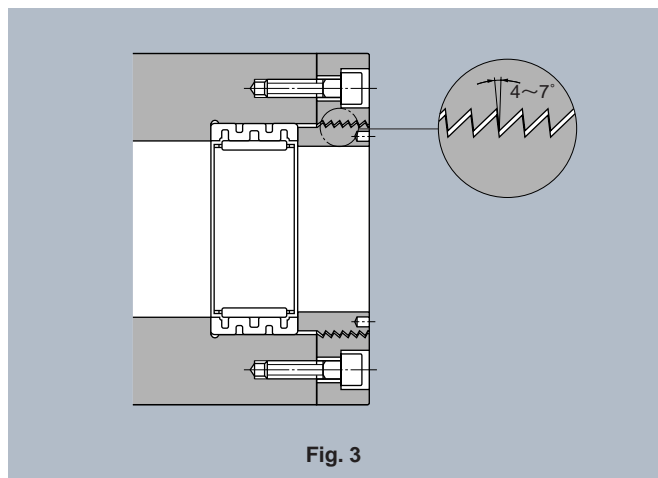
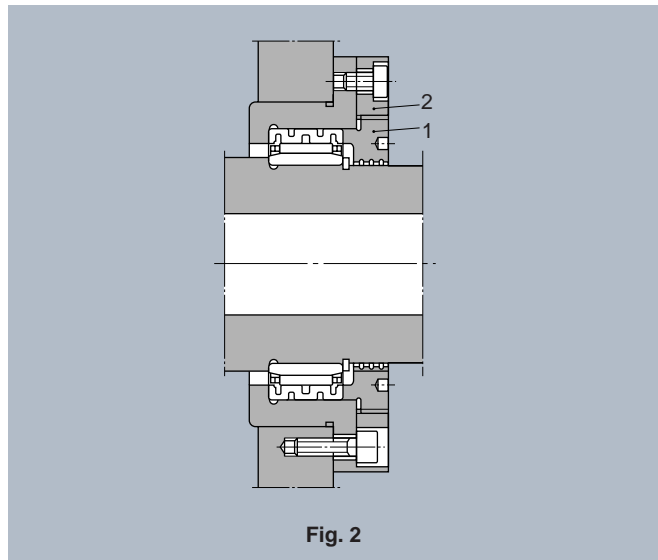
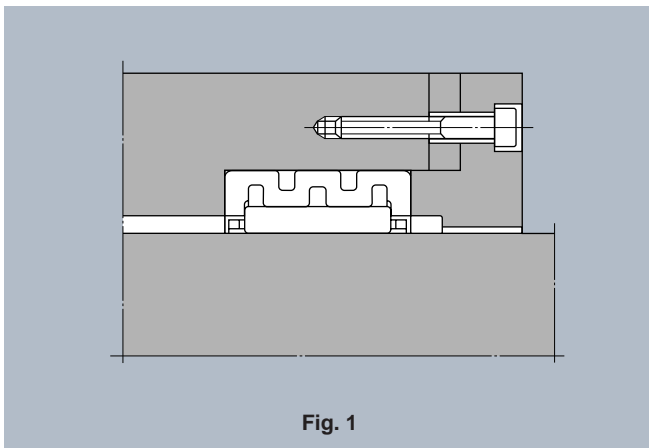

Without inner ring

Type RNA49·S

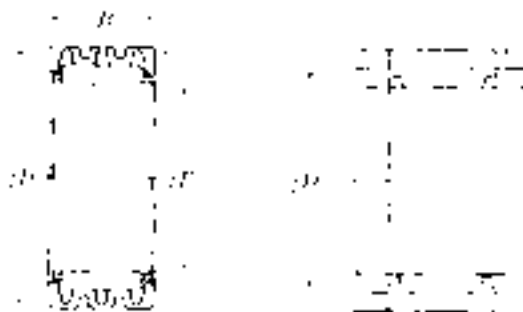

F_w 30~125mm

Boundary dimensions				Basic load ratings				Limiting speeds		Bearing numbers	Abutment dimensions		Mass kg (approx.)	
mm				dynamic	static	dynamic	static	r/min			D_a	r_{as}		
F_w	D	B	r_s min ¹⁾	C_r	C_{or}	C_r	C_{or}	grease	oil		max	max		
30	+0.031 +0.022	42	17	0.3	12 300	16 000	1 260	1 630	8 700	13 000	RNA 4905S	36	0.3	0.070
35	+0.038 +0.028	47	17	0.3	14 900	21 600	1 520	2 200	7 300	11 000	RNA 4906S	41	0.3	0.086
40	+0.038 +0.028	52	20	0.6	17 600	27 800	1 790	2 830	6 700	10 000	RNA49/32S	46	0.6	0.088
42	+0.038 +0.028	55	20	0.6	18 300	29 800	1 870	3 050	6 300	9 500	RNA 4907S	48	0.6	0.099
48	+0.038 +0.028	62	22	0.6	22 500	40 500	2 300	4 150	5 700	8 500	RNA 4908S	54	0.6	0.134
52	+0.045 +0.035	68	22	0.6	23 100	43 500	2 360	4 400	5 000	7 500	RNA 4909S	58	0.6	0.168
58	+0.045 +0.035	72	22	0.6	24 700	49 000	2 520	5 000	4 700	7 000	RNA 4910S	64	0.6	0.189
63	+0.045 +0.035	80	25	1	33 000	65 500	3 350	6 650	4 300	6 500	RNA 4911S	70	1	0.212
68	+0.045 +0.035	85	25	1	34 000	69 000	3 450	7 050	4 000	6 000	RNA 4912S	75	1	0.257
72	+0.045 +0.035	90	25	1	34 000	70 500	3 450	7 200	3 700	5 500	RNA 4913S	79	1	0.286
80	+0.045 +0.035	100	30	1	44 500	94 000	4 550	9 600	3 300	5 000	RNA 4914S	88	1	0.422
85	+0.055 +0.040	105	30	1	45 500	99 000	4 650	10 100	3 100	4 700	RNA 4915S	93	1	0.451
90	+0.055 +0.040	110	30	1	46 500	104 000	4 750	10 600	2 900	4 400	RNA 4916S	98	1	0.468
100	+0.055 +0.040	120	35	1.1	57 000	140 000	5 800	14 300	2 700	4 000	RNA 4917S	108	1	0.594
105	+0.055 +0.040	125	35	1.1	58 500	146 000	5 950	14 900	2 500	3 800	RNA 4918S	113	1	0.617
110	+0.055 +0.040	130	35	1.1	59 500	152 000	6 050	15 500	2 400	3 600	RNA 4919S	118	1	0.735
115	+0.055 +0.040	140	40	1.1	72 000	168 000	7 350	17 100	2 300	3 500	RNA 4920S	125	1	0.980
125	+0.065 +0.050	150	40	1.1	75 500	184 000	7 700	18 800	2 100	3 200	RNA 4922S	135	1	1.04

Note 1) Allowable minimum chamfer dimension r_s .

With inner ring

Type NA49··S

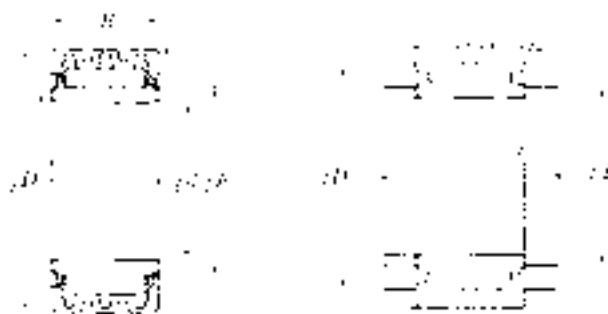

d 25~110mm

Boundary dimensions					Basic load ratings				Limiting speeds		Bearing numbers	Bearing clearance before installation	Abutment dimensions			Mass
mm					dynamic	static	dynamic	static	grease	oil			μm	d_a	D_a	
d	D	B	r_s min ¹⁾	F	C_r	C_{or}	C_r	C_{or}					min	max	max	(approx.)
25	42	17	0.3	30	12 300	16 000	1 260	1 630	8 700	13 000	NA 4905S	10~25	27	36	0.3	0.084
30	47	17	0.3	35	14 900	21 600	1 520	2 200	7 300	11 000	NA 4906S	12~25	32	41	0.3	0.099
32	52	20	0.6	40	17 600	27 800	1 790	2 830	6 700	10 000	NA49/32S	12~25	36	46	0.6	0.157
35	55	20	0.6	42	18 300	29 800	1 870	3 050	6 300	9 500	NA 4907S	15~30	39	48	0.6	0.164
40	62	22	0.6	48	22 500	40 500	2 300	4 150	5 700	8 500	NA 4908S	15~30	44	54	0.6	0.227
45	68	22	0.6	52	23 100	43 500	2 360	4 400	5 000	7 500	NA 4909S	15~35	49	58	0.6	0.257
50	72	22	0.6	58	24 700	49 000	2 520	5 000	4 700	7 000	NA 4910S	15~35	54	64	0.6	0.271
55	80	25	1	63	33 000	65 500	3 350	6 650	4 300	6 500	NA 4911S	15~35	60	70	1	0.382
60	85	25	1	68	34 000	69 000	3 450	7 050	4 000	6 000	NA 4912S	20~40	65	75	1	0.410
65	90	25	1	72	34 000	70 500	3 450	7 200	3 700	5 500	NA 4913S	20~40	70	79	1	0.427
70	100	30	1	80	44 500	94 000	4 550	9 600	3 300	5 000	NA 4914S	20~40	75	88	1	0.689
75	105	30	1	85	45 500	99 000	4 650	10 100	3 100	4 700	NA 4915S	25~45	80	93	1	0.740
80	110	30	1	90	46 500	104 000	4 750	10 600	2 900	4 400	NA 4916S	25~45	85	98	1	0.774
85	120	35	1.1	100	57 000	140 000	5 800	14 300	2 700	4 000	NA 4917S	25~45	91.5	108	1	1.18
90	125	35	1.1	105	58 500	146 000	5 950	14 900	2 500	3 800	NA 4918S	25~50	96.5	113	1	1.23
95	130	35	1.1	110	59 500	152 000	6 050	15 500	2 400	3 600	NA 4919S	25~50	101.5	118	1	1.40
100	140	40	1.1	115	72 000	168 000	7 350	17 100	2 300	3 500	NA 4920S	25~50	106.5	125	1	1.91
110	150	40	1.1	125	75 500	184 000	7 700	18 800	2 100	3 200	NA 4922S	30~60	116.5	135	1	2.12

Note 1) Allowable minimum chamfer dimension r .

Complex Bearings

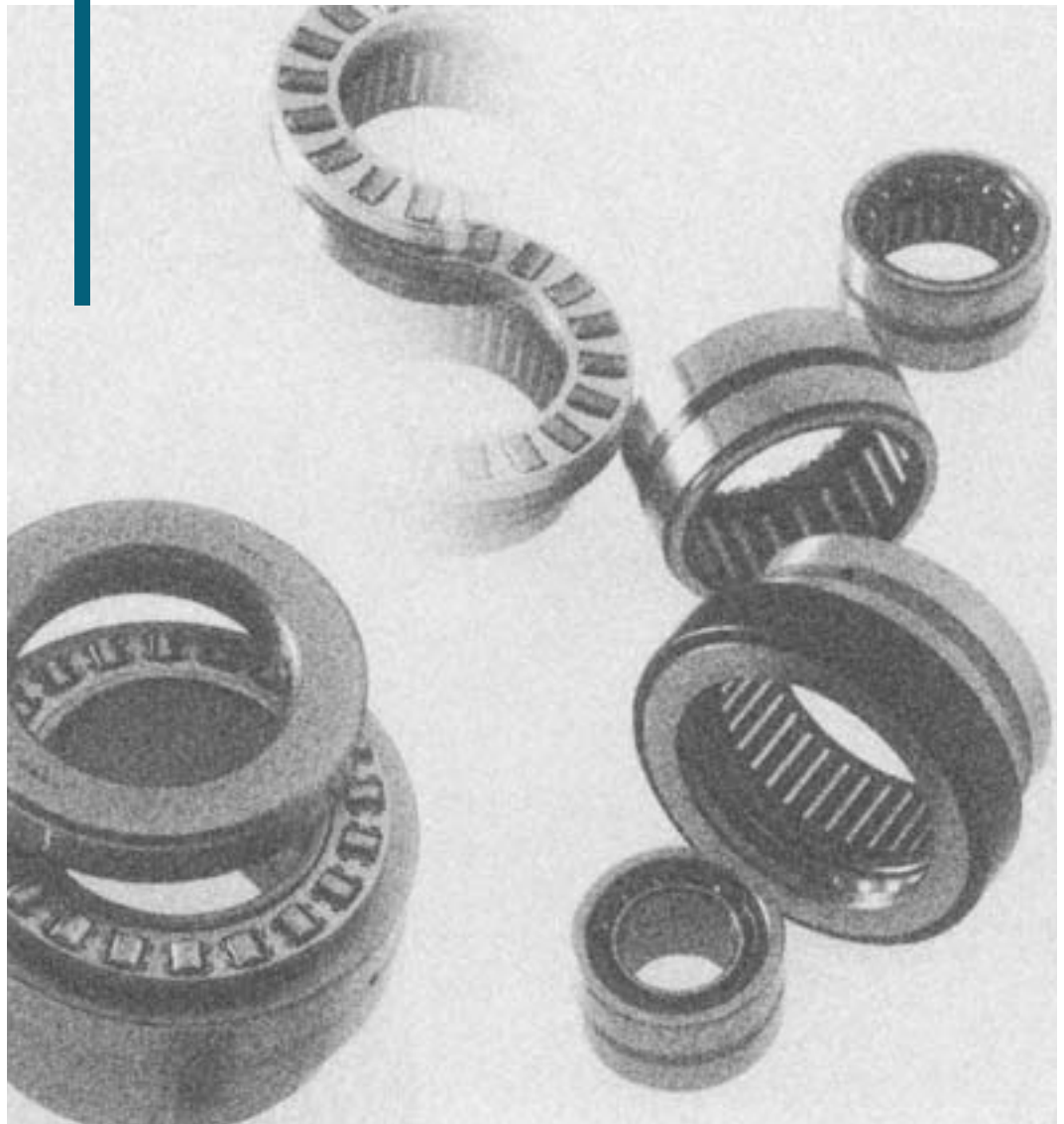





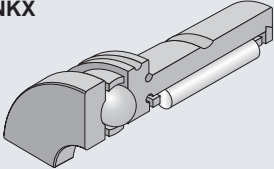
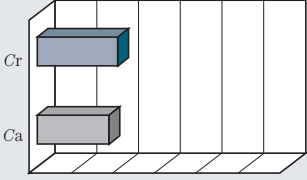
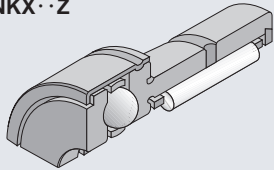
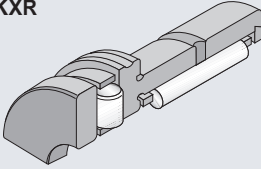
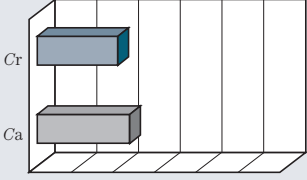
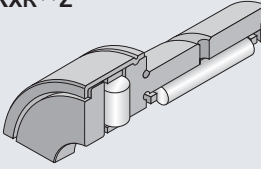
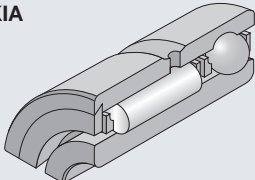
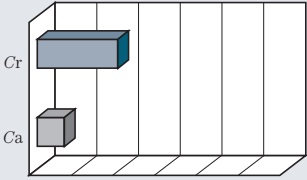
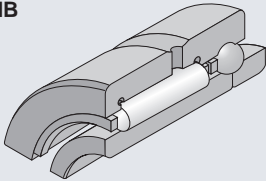
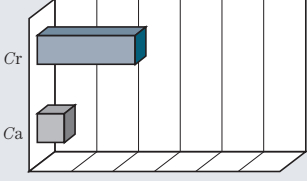
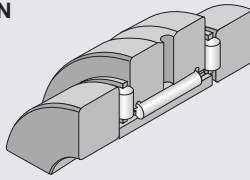
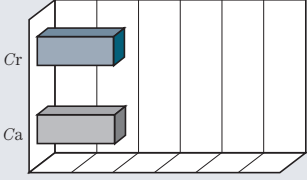
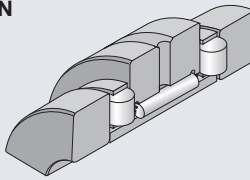
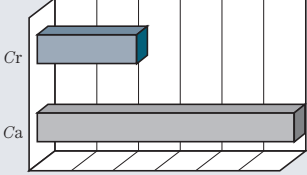

Complex Bearings

NTN complex bearing is composed of a radial needle roller bearing to support radial load and a thrust ball bearing or a thrust roller bearing to support axial load which are integrated into one bearing unit. Comparing with individual use of a radial bearing and a thrust bearing

for the same purpose, this complex bearing saves the required installation space and thereby can contribute to making the overall construction of an equipment more compact.

Bearing type	Applied shaft diameter (mm)	Load capacity	Composition of nominal bearing number
Type NKX 	$\phi 10 \sim \phi 70$		NKX 20 T2 Tail code T2: Resin cage Dimension code (shaft diameter) Type code
Type NKX·Z 			NKX 20 T2 Z Tail code T2: Resin cage Z: with dust-proof cover Dimension code (shaft diameter) Type code
Type NKXR 	$\phi 15 \sim \phi 50$		NKXR 20 T2 Tail code T2: Resin cage Dimension code (shaft diameter) Type code
Type NKXR·Z 			NKXR 20 T2Z Tail code T2: Resin cage Z: with dust-proof cover Dimension code (shaft diameter) Type code
Type NKIA 	$\phi 15 \sim \phi 70$		NKIA 59 04 Bore diameter code Dimension series code Type code
Type NKIB 	$\phi 15 \sim \phi 70$		NKIB 59 04 R Tail code R: outer ring with rib Bore diameter code Dimension series code Type code
Type AXN 	$\phi 20 \sim \phi 50$		AXN 20 52 Outer diameter code Bore diameter code Type code
Type ARN 	$\phi 20 \sim \phi 70$		ARN 20 62 Outer diameter code Bore diameter code Type code

※Each listed load capacity is subject to reference bearing bore diameter of $\phi 20$.

Bearing components	Handling characteristic	Features
Inscribed circle diameter (shaft dia.) : $\phi 20$ Radial bearing : Needle roller type Iron cage Thrust bearing : Ball type Resin cage Dust-proof cover : without Thrust plate : Separable	 Separable thrust plate Without dust-proof cover	Can be applied to high speed running under light axial load, due to use of ball type thrust bearing.
Inscribed circle diameter (shaft dia.) : $\phi 20$ Radial bearing : Needle roller type Iron cage Thrust bearing : Ball type Resin cage Dust-proof cover : with Thrust plate : Non-separable, integral type	 Integral thrust plate With dust-proof cover	This type is identical to NKZ, but its thrust bearing is provided with dust-proof cover to prevent grease scattering. Furthermore, the handling characteristic is good because the dust-proof cover makes the thrust plate non-separable integral.
Inscribed circle diameter (shaft dia.) : $\phi 20$ Radial bearing : Needle roller type Iron cage Thrust bearing : Ball type Resin cage Dust-proof cover : without Thrust plate : Separable	 Separable thrust plate Without dust-proof cover	Due to the use of needle roller bearing as its thrust bearing, this type can support greater axial load than NKX.
Inscribed circle diameter (shaft dia.) : $\phi 20$ Radial bearing : Needle roller type Iron cage Thrust bearing : Ball type Resin cage Dust-proof cover : with Thrust plate : Non-separable, integral type	 Integral thrust plate With dust-proof cover	This type is identical to NKXR, but its thrust bearing is provided with dust-proof cover to prevent grease scattering. Furthermore, the handling characteristic is good because the dust-proof cover makes the thrust plate non-separable and integral.
Inscribed circle diameter (shaft dia.) : $\phi 20$ Radial bearing : Needle roller type Thrust bearing : Angular type	 Integral angular bearing Inner ring separable	This type is composed of needle roller bearing and angular bearing which were integrated into one unit. The angular bearing supports axial load. Hence, this type can support one-way axial load only. Best-suited to high speed and light load application.
Inscribed circle diameter (shaft dia.) : $\phi 20$ Radial bearing : Needle roller type Outer ring with rib Thrust bearing : Three-point contact angular type	 Double inner ring type Inner ring separable	This type is composed of needle roller bearing and three-point contact angular bearing which were integrated into one unit. Unlike KN1A, this type can support bi-directional axial load.
Inscribed circle diameter (shaft dia.) : $\phi 20$ Outer ring outer diameter : 52 Radial bearing : Needle roller type Thrust bearing : Needle roller type	 Separable	This type is a special-purposed bearing to support a precision ball screw. This type uses the side face of the radial bearing as the raceway surface of thrust bearing. This can support axial load from both directions.
Inscribed circle diameter (shaft dia.) : $\phi 20$ Outer ring outer diameter : 62 Radial bearing : Needle roller type Thrust bearing : Cylindrical roller type	 Separable	This type is a special-purposed bearing to support a precision ball screw. This can support bi-directional axial load. This type is identical to AXN, but its axial load capacity is greater.

Bearing Accuracy

Regarding the dimensional tolerances for radial needle roller bearing, refer to **Table 4.3** of 4. "Bearing Tolerances" (page A-26) for others than the characteristics described in Dimensions Table and to **Table 4.4** (page A-26) for thrust bearing tolerances respectively. Manufacture of bearing **Type AXN** and **ARN** is limited to those of JIS accuracy class-5 and -4 only. (Allowable radial run-out values for Type AXN and ARN is as specified in **Table 1.**)

Table 1 Allowable radial run-out values for Type AXN and ARN
Unit: μm

Nominal bearing bore dia. d or nominal bearing outer dia. D (mm)		Radial runout of radial inner ring ^① K_{ia}		Allowable radial run-out for outer ring ^② K_{ea}	
Over	Incl.	Class 5	Class 4	Class 5	Class 4
18	30	4	3	—	—
30	50	5	4	—	—
50	80	5	4	8	5
80	120	—	—	10	6
120	150	—	—	11	7

- ① To be determined based on " d ".
- ② To be determined based on " D ".

Radial clearance

The respective radial clearances of **Type NKX+IR**, **NKXR+IR**, **NKIA** and **NKIB** shall comply with the interchangeable clearances specified in **Table 5.1** (1) of 5.1 "Radial Clearances of Bearings" (page A-30). The standard bearings are manufactured subject to the regular clearances.

The radial clearances of **Type AXN** and **ARN** is special clearance, as specified in applicable Dimensions Table.

Bearing fits

Radial needle roller bearings shall be fitted on shaft/in housing in compliance with **Table 2**. The thrust bearing washers of **Type NKX** and **NKXR** shall be fitted in a housing with hole diameter larger by 0.5mm or over than the washer outer diameter D_1 or D_2 . For **Type NKIA** and **NKIB** it is not allowed to make the interference greater than k5/M6.

Table 2 Bearing fit on shaft and in housing

Bearing type	Shaft	Housing
Series NKX, NKXR	k5	K6 (M6)
Series NKIA, NKIB	k5	M6
Series AXN, ARN	j5	J6

Remarks: The parenthesized housing code is applied, where high rigidity is required.

Calculation of rated life

The rated life (L) of any complex bearing is determined as follows. Determine individually the rated life (L_r) of radial needle roller bearing from radial load acting thereon and the rated life (L_a) of thrust bearing from axial load acting thereon. And determine the rated life (L) from these determined rated lives (L_r, L_a) using the following formula

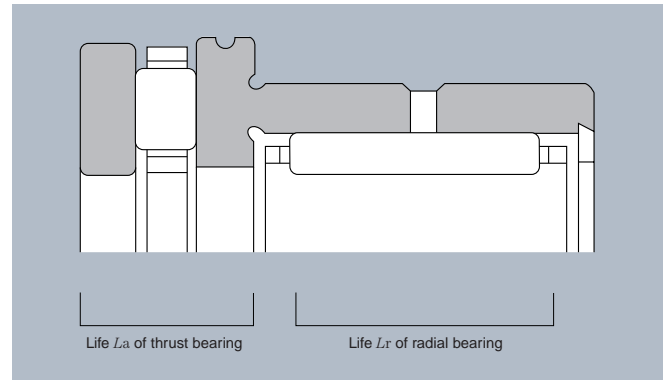

Rated life L of complex bearing

$$L = \frac{1}{\left(\frac{1}{L_r^{1.1}} + \frac{1}{L_a^{1.1}}\right)^{0.91}} \dots\dots\dots(1)$$

Without inner ring

Type NKX
Type NKX··Z

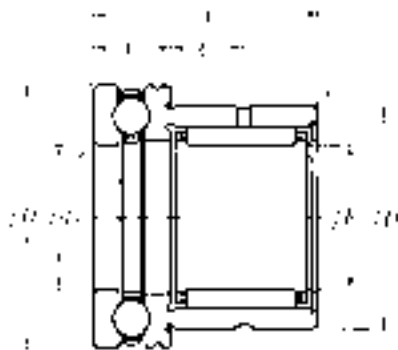

Type NKX
(Open type)

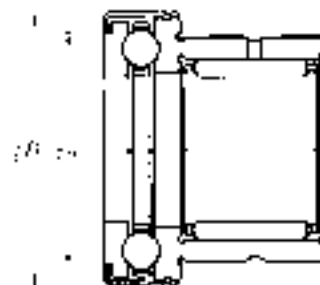

Type NKX··Z
(With cover)

F_w 10~70mm

F_w	Boundary dimensions											Basic load ratings			
	d_w	D	D_1	mm			C	C_1	C_2	a	$r_s \text{ min}^1)$	dynamic	static	dynamic	static
				D_2	C	C_1						N	kgf	kgf	kgf
10	+0.022 +0.013	10	+0.040 +0.025	19	24	25	23	9	6.5	19.7	0.3	5 450	6 450	555	660
12	+0.027 +0.016	12	+0.050 +0.032	21	26	27	23	9	6.5	21.7	0.3	6 000	7 700	615	785
15	+0.027 +0.016	15	+0.050 +0.032	24	28	29	23	9	6.5	23.7	0.3	8 250	10 200	840	1 040
17	+0.027 +0.016	17	+0.050 +0.032	26	30	31	25	9	8	25.7	0.3	10 400	14 400	1 060	1 460
20	+0.033 +0.020	20	+0.061 +0.040	30	35	36	30	10	10.5	30.7	0.3	16 400	27 100	1 670	2 760
25	+0.033 +0.020	25	+0.061 +0.040	37	42	43	30	11	9.5	37.7	0.6	14 200	24 000	1 450	2 450
30	+0.033 +0.020	30	+0.061 +0.040	42	47	48	30	11	9.5	42.7	0.6	22 300	39 500	2 280	4 000
35	+0.041 +0.025	35	+0.075 +0.050	47	52	53	30	12	9	47.7	0.6	20 000	36 000	2 040	3 650
40	+0.041 +0.025	40	+0.075 +0.050	52	60	61	32	13	10	55.7	0.6	25 900	52 500	2 650	5 350
45	+0.041 +0.025	45	+0.075 +0.050	58	65	66.5	32	14	9	60.5	0.6	27 600	59 000	2 810	6 000
50	+0.041 +0.025	50	+0.075 +0.050	62	70	71.5	35	14	10	65.5	0.6	27 900	62 000	2 850	6 300
60	+0.049 +0.030	60	+0.090 +0.060	72	85	86.5	40	17	12	80.5	1	29 800	71 500	3 050	7 300
70	+0.049 +0.030	70	+0.090 +0.060	85	95	96.5	40	18	11	90.5	1	36 500	86 000	3 700	8 750

Note 1) Allowable minimum chamfer dimension r_s .

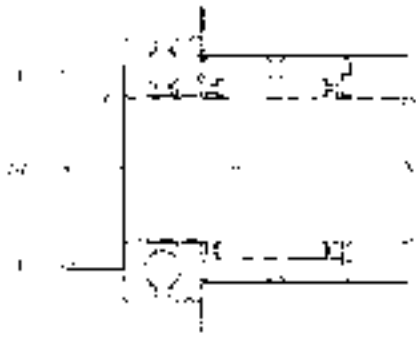

dynamic N	Basic load ratings		Limiting dimensions r/min	Bearing numbers		Abutment dimensions mm		Mass (approx.) kg			
	static	dynamic		grease	oil	d_a min	r_{as} max	Type NKX	Type NKX··Z		
	C_{oa}	C_a								kgf	static
10 000	14 000	1 020	1 420	6 700	9 500	NKX10T2	NKX10T2Z	18	0.3	0.037	0.039
10 300	15 400	1 050	1 570	6 400	9 200	NKX12T2	NKX12T2Z	20	0.3	0.042	0.044
10 500	16 800	1 070	1 710	6 200	8 800	NKX15T2	NKX15T2Z	23	0.3	0.044	0.048
10 800	18 200	1 100	1 850	6 000	8 500	NKX17T2	NKX17T2Z	25	0.3	0.051	0.056
14 200	24 700	1 450	2 520	5 200	7 500	NKX20T2	NKX20T2Z	29	0.3	0.085	0.090
19 600	37 000	1 990	3 800	4 600	6 500	NKX25T2	NKX25T2Z	35	0.6	0.125	0.132
20 400	42 000	2 080	4 300	4 300	6 200	NKX30T2	NKX30T2Z	40	0.6	0.140	0.148
20 400	44 500	2 080	4 550	3 900	5 600	NKX35T2	NKX35T2Z	45	0.6	0.167	0.175
26 900	63 000	2 740	6 400	3 500	5 000	NKX40	NKX40Z	52	0.6	0.216	0.225
27 900	69 000	2 840	7 050	3 200	4 600	NKX45	NKX45Z	57	0.6	0.252	0.265
28 800	75 500	2 930	7 700	3 100	4 500	NKX50	NKX50Z	62	0.6	0.302	0.318
41 500	113 000	4 200	11 500	2 600	3 700	NKX60	NKX60Z	75	1	0.465	0.484
43 000	127 000	4 400	12 900	2 400	3 400	NKX70	NKX70Z	85	1	0.612	0.635

With inner ring

Type NKX+IR
Type NKX·Z+IR

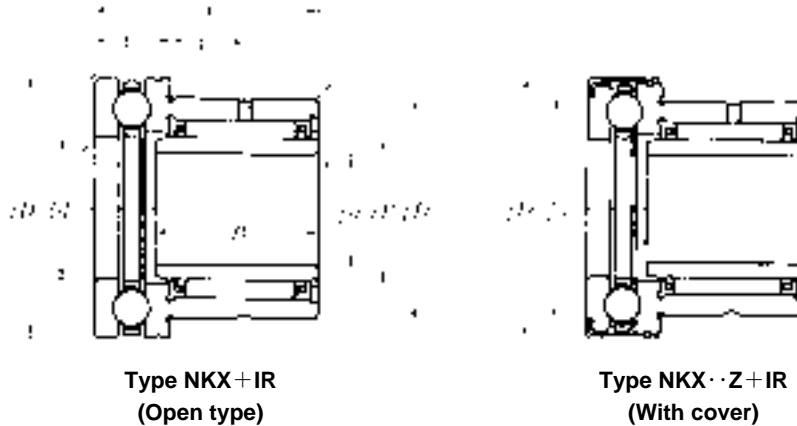

d 7~60mm

Boundary dimensions													Basic load ratings								
d	d _w	D	D ₁	D ₂	B	C	C ₁	C ₂	F	a	r _{s min} ¹⁾	r _{1s min} ¹⁾	dynamic		static		dynamic		static		
													N		kgf		N		kgf		
													Radial				Axial				
													C _r	C _{or}	C _r	C _{or}	C _a	C _{oa}	C _a	C _{oa}	
7	10	+0.040 +0.025	19	24	25	16	23	9	6.5	10	19.7	0.3	0.3	5 450	6 450	555	660	10 000	14 000	1 020	1 420
9	12	+0.050 +0.032	21	26	27	16	23	9	6.5	12	21.7	0.3	0.3	6 000	7 700	615	785	10 300	15 400	1 050	1 570
12	15	+0.050 +0.032	24	28	29	16	23	9	6.5	15	23.7	0.3	0.3	8 250	10 200	840	1 040	10 500	16 800	1 070	1 710
14	17	+0.050 +0.040	26	30	31	17	25	9	8	17	25.7	0.3	0.3	10 400	14 400	1 060	1 460	10 800	18 200	1 100	1 850
17	20	+0.061 +0.040	30	35	36	20	30	10	10.5	20	30.7	0.3	0.3	16 400	27 100	1 670	2 760	14 200	24 700	1 450	2 520
20	25	+0.061 +0.040	37	42	43	20	30	11	9.5	25	37.7	0.6	0.3	14 200	24 000	1 450	2 450	19 600	37 000	1 990	3 800
25	30	+0.061 +0.040	42	47	48	20	30	11	9.5	30	42.7	0.6	0.3	22 300	39 500	2 280	4 000	20 400	42 000	2 080	4 300
30	35	+0.075 +0.050	47	52	53	20	30	12	9	35	47.7	0.6	0.3	20 000	36 000	2 040	3 650	20 400	44 500	2 080	4 550
35	40	+0.075 +0.050	52	60	61	20	32	13	10	40	55.7	0.6	0.3	25 900	52 500	2 650	5 350	26 900	63 000	2 740	6 400
40	45	+0.075 +0.050	58	65	66.5	20	32	14	9	45	60.5	0.6	0.3	27 600	59 000	2 810	6 000	27 900	69 000	2 840	7 050
45	50	+0.075 +0.050	62	70	71.5	25	35	14	10	50	65.5	0.6	0.6	27 900	62 000	2 850	6 300	28 800	75 500	2 930	7 700
50	60	+0.090 +0.060	72	85	86.5	25	40	17	12	60	80.5	1	1	29 800	71 500	3 050	7 300	41 500	113 000	4 200	11 500
60	70	+0.090 +0.060	85	95	96.5	25	40	18	11	70	90.5	1	1	36 500	86 000	3 700	8 750	43 000	127 000	4 400	12 900

Note 1) Allowable minimum chamfer dimension r.

Remarks: Nominal code number of inner ring comprises IR. Bore diameter×outer diameter×width.

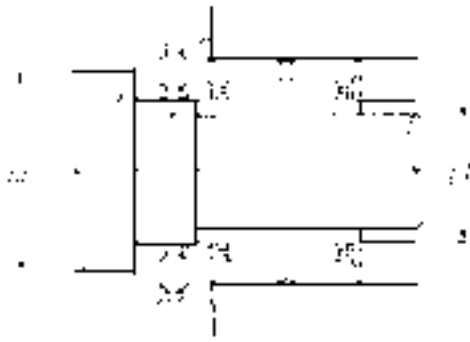

Limiting dimensions r/min		Bearing numbers		Abutment dimensions mm				Mass (approx.) kg	
grease	oil	Type NKX+IR	Type NKX·Z+IR	d_a min	d_b min	r_{as} max	r_{1as} max	Type NKX+IR	Type NKX·Z+IR
6 700	9 500	NKX10T2+IR 7×10×16	NKX10T2Z+IR 7×10×16	18	9	0.3	0.3	0.042	0.044
6 400	9 200	NKX12T2+IR 9×12×16	NKX12T2Z+IR 9×12×16	20	11	0.3	0.3	0.048	0.050
6 200	8 800	NKX15T2+IR12×15×16	NKX15T2Z+IR12×15×16	23	14	0.3	0.3	0.052	0.056
6 000	8 500	NKX17T2+IR14×17×17	NKX17T2Z+IR14×17×17	25	16	0.3	0.3	0.061	0.066
5 200	7 500	NKX20T2+IR17×20×20	NKX20T2Z+IR17×20×20	29	19	0.3	0.3	0.099	0.104
4 600	6 500	NKX25T2+IR20×25×20	NKX25T2Z+IR20×25×20	35	22	0.6	0.3	0.152	0.159
4 300	6 200	NKX30T2+IR25×30×20	NKX30T2Z+IR25×30×20	40	27	0.6	0.3	0.173	0.181
3 900	5 600	NKX35T2+IR30×35×20	NKX35T2Z+IR30×35×20	45	32	0.6	0.3	0.205	0.213
3 500	5 000	NKX40 +IR35×40×20	NKX40Z +IR35×40×20	52	37	0.6	0.3	0.260	0.269
3 200	4 600	NKX45 +IR40×45×20	NKX45Z +IR40×45×20	57	42	0.6	0.3	0.293	0.316
3 100	4 500	NKX50 +IR45×50×25	NKX50Z +IR45×50×25	62	48	0.6	0.6	0.373	0.389
2 600	3 700	NKX60 +IR50×60×25	NKX60Z +IR50×60×25	75	55	1	1	0.635	0.654
2 400	3 400	NKX70 +IR60×70×25	NKX70Z +IR60×70×25	85	65	1	1	0.814	0.837

Without inner ring

Type NKXR
Type NKXR···Z

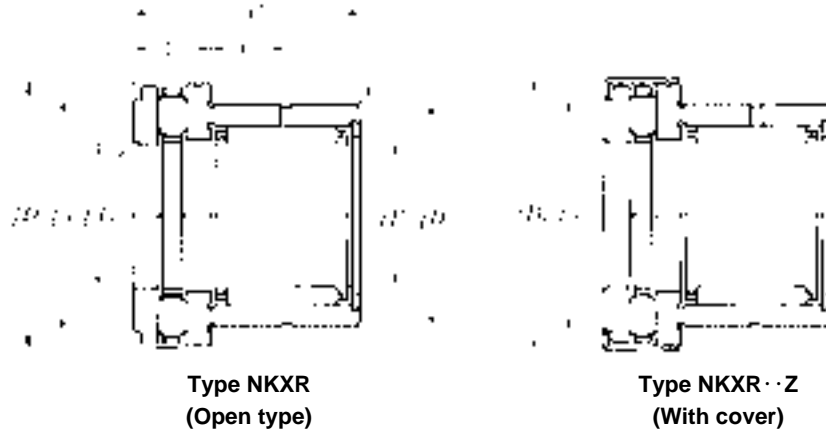

Type NKXR
(Open type)

Type NKXR···Z
(With cover)

F_w 15~50mm

F_w	d_w	Boundary dimensions									Basic load ratings			
		D	D_1	mm			a	$r_s \text{ min}^{1)}$	dynamic C_r	static C_{or}	dynamic C_r	static C_{or}		
				D_2	C 0 -0.25	C_1 0 -0.20							C_2	N
15	15	24	28	29	23	9	6.5	23.7	0.3	8 250	10 200	840	1 040	
17	17	26	30	31	25	9	8	25.7	0.3	10 400	14 400	1 060	1 460	
20	20	30	35	36	30	10	10.5	30.7	0.3	16 400	27 100	1 670	2 760	
25	25	37	42	43	30	11	9.5	37.7	0.6	14 200	24 000	1 450	2 450	
30	30	42	47	48	30	11	9.5	42.7	0.6	22 300	39 500	2 280	4 000	
35	35	47	52	53	30	12	9	47.7	0.6	20 000	36 000	2 040	3 650	
40	40	52	60	61	32	13	10	55.7	0.6	25 900	52 500	2 650	5 350	
45	45	58	65	66.5	32	14	9	60.5	0.6	27 600	59 000	2 810	6 000	
50	50	62	70	71.5	35	14	10	65.5	0.6	27 900	62 000	2 850	6 300	

Note 1) Allowable minimum chamfer dimension r_s .

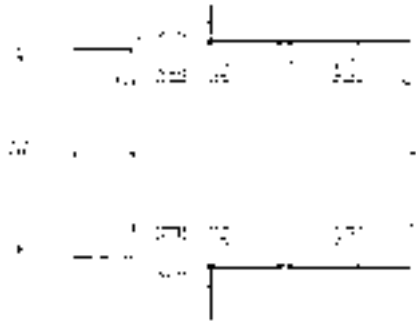

dynamic C_a	Basic load ratings				Limiting dimensions		Bearing numbers		Abutment dimensions		Mass (approx.)	
	static N	dynamic	dynamic	static	r/min	oil	Type NKXR	Type NKXR·Z	mm		Type NKXR	Type NKXR·Z
	C_{oa}	Axial C_a	Axial C_a	C_{oa}					kgf	d_a min		
12 900	28 600	1 310	2 920	2 800	11 000	NKXR15T2	NKXR15T2Z	25	0.3	0.048	0.052	
13 400	31 000	1 370	3 150	2 500	10 000	NKXR17T2	NKXR17T2Z	27	0.3	0.050	0.053	
20 200	46 500	2 060	4 700	2 100	8 500	NKXR20T2	NKXR20T2Z	32	0.3	0.090	0.095	
27 300	68 000	2 780	6 900	1 800	7 000	NKXR25T2	NKXR25T2Z	39	0.6	0.128	0.135	
27 800	72 500	2 840	7 400	1 500	6 000	NKXR30T2	NKXR30T2Z	44	0.6	0.162	0.169	
31 000	87 000	3 150	8 900	1 400	5 500	NKXR35T2	NKXR35T2Z	49	0.6	0.184	0.195	
43 000	121 000	4 350	12 400	1 200	4 800	NKXR40T2	NKXR40T2Z	56	0.6	0.226	0.237	
45 500	135 000	4 650	13 800	1 100	4 400	NKXR45T2	NKXR45T2Z	61	0.6	0.267	0.286	
48 000	150 000	4 900	15 300	1 000	4 000	NKXR50T2	NKXR50T2Z	66	0.6	0.309	0.329	

With inner ring

Type NKXR+IR
Type NKXR··Z+IR

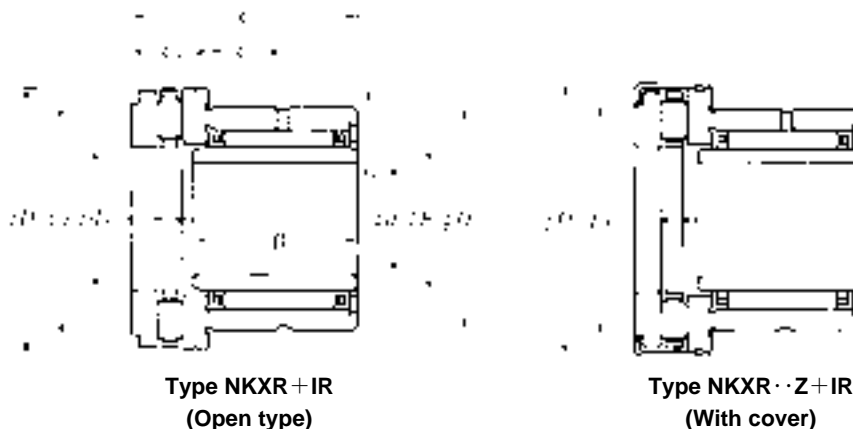

d 12~45mm

Boundary dimensions														Basic load ratings										
d	d _w	D	D ₁	D ₂	mm									a	r _{s min} ¹⁾	r _{1s min} ¹⁾	dynamic N	static N	dynamic kgf	static kgf	dynamic N	static N	dynamic kgf	static kgf
					B	C	C ₁	C ₂	F	Radial		Axial												
					0	0	0	0	0	C _r	C _{or}	C _a	C _{oa}											
12	15 ^{+0.050} / _{+0.032}	24	28	29	16	23	9	6.5	15	23.7	0.3	0.3	8 250	10 200	840	1 040	12 900	28 600	1 310	2 920				
14	17 ^{+0.050} / _{+0.032}	26	30	31	17	25	9	8	17	25.7	0.3	0.3	10 400	14 400	1 060	1 460	13 400	31 000	1 370	3 150				
17	20 ^{+0.061} / _{+0.040}	30	35	36	20	30	10	10.5	20	30.7	0.3	0.3	16 400	27 100	1 670	2 760	20 200	46 500	2 060	4 700				
20	25 ^{+0.061} / _{+0.040}	37	42	43	20	30	11	9.5	25	37.7	0.6	0.3	14 200	24 000	1 450	2 450	27 300	68 000	2 780	6 900				
25	30 ^{+0.061} / _{+0.040}	42	47	48	20	30	11	9.5	30	42.7	0.6	0.3	22 300	39 500	2 280	4 000	27 800	72 500	2 840	7 400				
30	35 ^{+0.075} / _{+0.050}	47	52	53	20	30	12	9	35	47.7	0.6	0.3	20 000	36 000	2 040	3 650	31 000	87 000	3 150	8 900				
35	40 ^{+0.075} / _{+0.050}	52	60	61	20	32	13	10	40	55.7	0.6	0.3	25 900	52 500	2 650	5 350	43 000	121 000	4 350	12 400				
40	45 ^{+0.075} / _{+0.050}	58	65	66.5	20	32	14	9	45	60.5	0.6	0.3	27 600	59 000	2 810	6 000	45 500	135 000	4 650	13 800				
45	50 ^{+0.075} / _{+0.050}	62	70	71.5	25	35	14	10	50	65.5	0.6	0.6	27 900	62 000	2 850	6 300	48 000	150 000	4 900	15 300				

Note 1) Allowable minimum chamfer dimension r' or r1.

Remarks: Nominal code number of inner ring comprises IR. Bore diameter×outer diameter×width.



Limiting dimensions r/min grease oil		Bearing numbers Type NKXR+IR Type NKXR··Z+IR		Abutment dimensions mm				Mass (approx.) kg	
				d_a min	d_b min	r_{as} max	r_{ias} max	Type NKXR+IR	Type NKXR··Z+IR
2 800	11 000	NKXR15T2+IR12×15×16	NKXR15T2Z+IR12×15×16	25	14	0.3	0.3	0.056	0.060
2 500	10 000	NKXR17T2+IR14×17×17	NKXR17T2Z+IR14×17×17	27	16	0.3	0.3	0.060	0.063
2 100	8 500	NKXR20T2+IR17×20×20	NKXR20T2Z+IR17×20×20	32	19	0.3	0.3	0.105	0.110
1 800	7 000	NKXR25T2+IR20×25×20	NKXR25T2Z+IR20×25×20	39	22	0.6	0.3	0.155	0.162
1 500	6 000	NKXR30T2+IR25×30×20	NKXR30T2Z+IR25×30×20	44	27	0.6	0.3	0.197	0.202
1 400	5 500	NKXR35T2+IR30×35×20	NKXR35T2Z+IR30×35×20	49	32	0.6	0.3	0.224	0.235
1 200	4 800	NKXR40T2+IR35×40×20	NKXR40T2Z+IR35×40×20	56	37	0.6	0.3	0.270	0.281
1 100	4 400	NKXR45T2+IR40×45×20	NKXR45T2Z+IR40×45×20	61	42	0.6	0.3	0.318	0.337
1 000	4 000	NKXR50T2+IR45×50×25	NKXR50T2Z+IR45×50×25	66	48	0.6	0.6	0.379	0.400

Type NKIA59

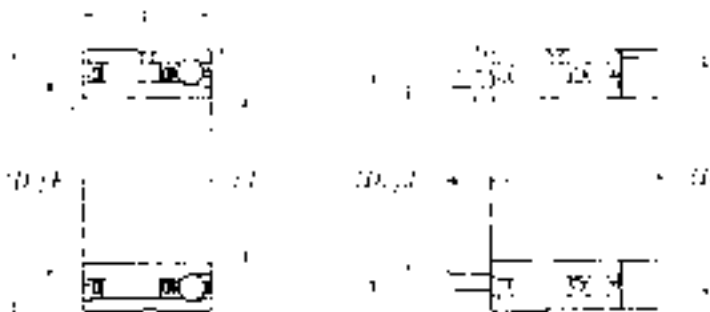

d 15~70mm

Boundary dimensions					Basic load ratings								Limiting dimensions	
mm					N				kgf				r/min	
d	D	C	F	$r_{s\min}^{1)}$	Radial				Axial				grease	oil
					C_r	C_{or}	C_r	C_{or}	C_a	C_{oa}	C_a	C_{oa}		
15	28	18	20	0.3	9 500	13 400	970	1 370	2 340	3 050	239	310	13 000	20 000
17	30	18	22	0.3	10 100	14 900	1 030	1 520	2 530	3 550	258	360	12 000	18 000
20	37	23	25	0.3	16 500	22 100	1 680	2 250	4 700	6 150	480	625	11 000	16 000
22	39	23	28	0.3	17 500	24 800	1 790	2 530	4 900	6 750	500	690	9 500	14 000
25	42	23	30	0.3	17 400	25 000	1 770	2 550	5 100	7 350	520	750	8 500	13 000
30	47	23	35	0.3	19 400	30 500	1 980	3 100	5 400	8 550	550	870	7 500	11 000
35	55	27	42	0.6	25 700	46 000	2 630	4 700	7 400	12 300	755	1 260	6 500	9 500
40	62	30	48	0.6	31 000	61 000	3 150	6 250	7 750	14 000	790	1 430	5 500	8 500
45	68	30	55	0.6	33 000	69 500	3 350	7 100	8 500	17 100	870	1 740	5 000	7 500
50	72	30	60	0.6	33 500	73 500	3 450	7 500	8 800	18 700	900	1 910	4 300	6 500
55	80	34	63	1	44 500	95 500	4 500	9 700	14 300	33 000	1 460	3 350	4 300	6 500
60	85	34	68	1	45 500	101 000	4 600	10 300	14 800	36 000	1 510	3 650	4 000	6 000
65	90	34	75	1	46 000	106 000	4 700	10 800	15 200	39 000	1 550	4 000	3 700	5 500
70	100	40	80	1	62 500	146 000	6 350	14 900	18 600	47 500	1 890	4 850	3 300	5 000

Note 1) Allowable minimum chamfer dimension r^* or r_1 .
Remarks: This complex can support bi-directional axial load.

Bearing numbers	Abutment dimensions mm				Mass kg (approx.)
	d_a min	D_a max	D_b max	r_{as} max	
NKIA 5902	17.5	22	25.5	0.3	0.050
NKIA 5903	19.5	24	27.5	0.3	0.056
NKIA 5904	22.5	28	34.5	0.3	0.111
NKIA59/22	24.5	31	36.5	0.3	0.120
NKIA 5905	27.5	33	39.5	0.3	0.130
NKIA 5906	32.5	38	44.5	0.3	0.147
NKIA 5907	40	45	50	0.6	0.243
NKIA 5908	45	51	57	0.6	0.347
NKIA 5909	50	58	63	0.6	0.401
NKIA 5910	55	63	67	0.6	0.410
NKIA 5911	61	66.5	74	1	0.590
NKIA 5912	66	71.5	79	1	0.632
NKIA 5913	71	78.5	84	1	0.708
NKIA 5914	76	84	94	1	1.05

Type NKIB 59



d 15~70mm

Boundary dimensions						Basic load ratings								Limiting dimensions	
d	D	mm			r_s min ¹⁾	dynamic				static				grease	oil
		B	C	F		N		kgf		N		kgf			
		$\begin{matrix} 0 \\ -0.3 \end{matrix}$				Radial				Axial					
						C_r	C_{or}	C_r	C_{or}	C_a	C_{oa}	C_a	C_{oa}		
15	28	20	18	20	0.3	10 800	13 600	1 100	1 390	2 750	4 200	280	430	13 000	20 000
17	30	20	18	22	0.3	11 200	14 600	1 140	1 490	2 960	4 900	300	495	12 000	18 000
20	37	25	23	25	0.3	21 300	25 500	2 170	2 600	4 650	7 400	475	755	11 000	16 000
22	39	25	23	28	0.3	23 200	29 300	2 360	2 990	5 000	8 650	510	880	9 500	14 000
25	42	25	23	30	0.3	24 000	31 500	2 450	3 200	5 150	9 250	525	945	8 500	13 000
30	47	25	23	35	0.3	25 500	35 500	2 600	3 600	5 600	11 200	570	1 140	7 500	11 000
35	55	30	27	42	0.6	32 000	50 000	3 300	5 100	7 050	14 900	720	1 520	6 500	9 500
40	62	34	30	48	0.6	43 500	66 500	4 450	6 800	8 700	19 400	890	1 980	5 500	8 500
45	68	34	30	52	0.6	46 000	73 000	4 700	7 450	9 100	21 400	925	2 180	5 000	7 500
50	72	34	30	58	0.6	48 000	80 000	4 900	8 150	9 600	24 300	980	2 480	4 300	6 500
55	80	38	34	63	1	58 500	99 500	6 000	10 100	11 400	29 400	1 170	3 000	4 300	6 500
60	85	38	34	68	1	61 500	108 000	6 250	11 000	11 800	32 000	1 200	3 250	4 000	6 000
65	90	38	34	72	1	62 500	112 000	6 350	11 400	12 100	34 000	1 240	3 500	3 700	5 500
70	100	45	40	80	1	85 500	156 000	8 750	15 900	15 900	44 500	1 620	4 550	3 300	5 000

Note 1) Allowable minimum chamfer dimension r .

Remarks: 1. This complex can support bi-directional axial load.

2. The ball bearing of this complex bearing is complete with a synthetic resin cage, and the allowable operating temperature shall be 120°C and, under continuous running, 100°C or less.

3. This bearing type is the imported product from INA, Germany.

Bearing numbers	Abutment dimensions mm			Mass kg (approx.)
	d_a min	D_a max	r_{as} max	
NKIB 5902R	17.5	25.5	0.3	0.052
NKIB 5903R	19.5	27.5	0.3	0.058
NKIB 5904R	22.5	34.5	0.3	0.107
NKIB59/22R	24.5	36.5	0.3	0.122
NKIB 5905R	27.5	39.5	0.3	0.134
NKIB 5906R	32.5	44.5	0.3	0.151
NKIB 5907R	40	50	0.6	0.247
NKIB 5908R	45	57	0.6	0.320
NKIB 5909R	50	63	0.6	0.380
NKIB 5910R	55	67	0.6	0.385
NKIB 5911R	61	74	1	0.555
NKIB 5912R	66	79	1	0.595
NKIB 5913R	71	84	1	0.640
NKIB 5914R	76	94	1	0.985

Type AXN

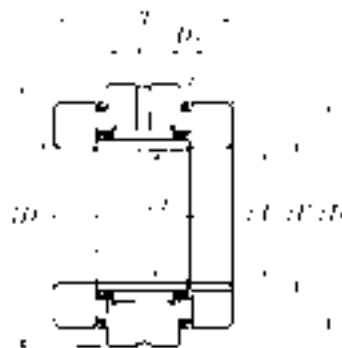

d 20~50mm

Boundary dimensions										Basic load ratings								
d	d _w	D	mm					D _w	r _{s min} ¹⁾	r _{1s min} ¹⁾	dynamic	static	dynamic	static	dynamic	static	dynamic	static
			D ₁	T	C	F	N				N	N	N	N	N	N	N	
			-0.20 -0.50	0 -0.370	0 -0.130													
										Radial				Axial				
										C _r	C _{or}	C _r	C _{or}	C _a	C _{oa}	C _a	C _{oa}	
20	20 ^{+0.061} _{+0.040}	52	42	40	16	25	2	0.6	0.6	15 100	22 400	1 540	2 280	14 600	58 000	1 490	5 900	
25	25 ^{+0.061} _{+0.040}	57	47	44	20	30	2	0.6	0.6	22 100	34 000	2 260	3 500	16 300	69 500	1 660	7 100	
30	30 ^{+0.061} _{+0.040}	62	52	44	20	35	2	0.6	0.6	24 800	41 500	2 520	4 250	17 800	81 500	1 820	8 300	
35	35 ^{+0.075} _{+0.050}	70	60	48	20	40	3	1	0.6	26 400	47 000	2 700	4 800	27 400	110 000	2 790	11 300	
40	40 ^{+0.075} _{+0.050}	75	65	48	20	45	3	1	0.6	28 000	52 500	2 860	5 400	29 800	128 000	3 050	13 100	
45	45 ^{+0.075} _{+0.050}	80	70	54	25	50	3	1	0.6	38 500	74 500	3 950	7 550	31 500	143 000	3 250	14 500	
50	50 ^{+0.075} _{+0.050}	90	78	54	25	55	3	1	0.6	41 000	82 000	4 150	8 400	38 000	186 000	3 850	19 000	

Note 1) Allowable minimum chamfer dimension r' or r₁.

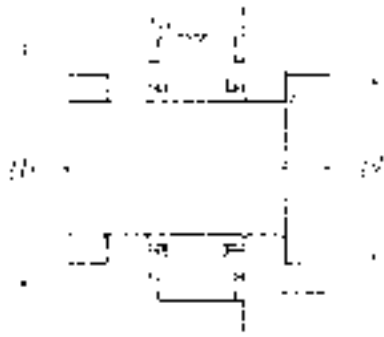

Limiting dimensions r/min		Bearing numbers	Radial clearance μm		Abutment dimensions mm				Preload		Starting torque ²⁾		Mass
grease	oil		min	max	d_a min	D_a max	r_{as} max	r_{1as} max	N	kgf	N·mm	kgf·mm	kg
1 800	7 000	AXN2052	10	30	39	46	0.6	0.6	1 300	130	330	33	0.400
1 500	6 000	AXN2557	10	30	44	51	0.6	0.6	1 450	145	400	40	0.520
1 400	5 500	AXN3062	10	40	50	56	0.6	0.6	1 600	160	550	55	0.590
1 200	4 700	AXN3570	10	40	56	64	1	0.6	2 450	245	900	90	0.800
1 100	4 300	AXN4075	10	40	62	69	1	0.6	2 650	265	1 050	105	0.890
1 000	3 900	AXN4580	10	40	67	74	1	0.6	2 800	280	1 200	120	1.00
900	3 500	AXN5090	15	50	75	83	1	0.6	3 400	340	1 600	160	1.42

Note 2) Starting torque subject to standard preload.

Type ARN

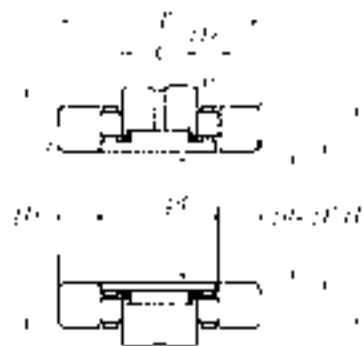

d 20~70mm

Boundary dimensions										Basic load ratings									
d	d_w	D	mm					D_w	$r_{s \min}^{1)}$	$r_{1s \min}^{1)}$	dynamic		static		dynamic		static		
			D_1	T	C	F	r				N	N	kgf	kgf	N	N	kgf	kgf	
			-0.20 -0.50	0 -0.370	0 -0.130					C_r	C_{or}	Radial	C_r	C_{or}	Axial	C_a	C_{oa}	C_a	C_{oa}
20	20 ^{+0.061} _{+0.040}	52	42	46	16	25	5	0.6	0.6	15 100	22 400	1 540	2 280	27 300	68 000	2 780	6 900		
20	20 ^{+0.061} _{+0.040}	62	52	60	20	30	7.5	1	0.6	22 100	34 000	2 260	3 500	53 500	129 000	5 450	13 100		
25	25 ^{+0.061} _{+0.040}	57	47	50	20	30	5	0.6	0.6	22 100	34 000	2 260	3 500	27 800	72 500	2 840	7 400		
25	25 ^{+0.061} _{+0.040}	72	62	60	20	35	7.5	1	0.6	24 800	41 500	2 520	4 250	54 500	139 000	5 550	14 200		
30	30 ^{+0.061} _{+0.040}	62	52	50	20	35	5	0.6	0.6	24 800	41 500	2 520	4 250	31 000	87 000	3 150	8 900		
30	30 ^{+0.061} _{+0.040}	80	68	66	20	40	9	1	0.6	26 400	47 000	2 700	4 800	74 500	190 000	7 600	19 400		
35	35 ^{+0.075} _{+0.050}	70	60	54	20	40	6	1	0.6	26 400	47 000	2 700	4 800	43 000	121 000	4 350	12 400		
35	35 ^{+0.075} _{+0.050}	85	73	66	20	45	9	1	0.6	28 000	52 500	2 860	5 400	82 000	222 000	8 350	22 600		
40	40 ^{+0.075} _{+0.050}	75	65	54	20	45	6	1	0.6	28 000	52 500	2 860	5 400	45 500	135 000	4 650	13 800		
40	40 ^{+0.075} _{+0.050}	90	78	75	25	50	9	1	0.6	38 500	74 500	3 950	7 550	85 000	238 000	8 650	24 200		
45	45 ^{+0.075} _{+0.050}	80	70	60	25	50	6	1	0.6	38 500	74 500	3 950	7 550	48 000	150 000	4 900	15 300		
45	45 ^{+0.075} _{+0.050}	105	90	82	25	55	11	1	0.6	41 000	82 000	4 150	8 400	121 000	340 000	12 300	34 500		
50	50 ^{+0.075} _{+0.050}	90	78	60	25	55	6	1	0.6	41 000	82 000	4 150	8 400	62 500	215 000	6 350	21 900		
50	50 ^{+0.075} _{+0.050}	110	95	82	25	60	11	1.1	0.6	41 000	85 000	4 200	8 700	125 000	365 000	12 800	37 000		
55	55 ^{+0.090} _{+0.060}	115	100	82	25	65	11	1.1	0.6	44 500	98 000	4 550	10 000	130 000	385 000	13 200	39 500		
60	60 ^{+0.090} _{+0.060}	120	105	82	25	70	11	1.1	0.6	45 000	91 500	4 600	9 350	134 000	410 000	13 700	42 000		
65	65 ^{+0.090} _{+0.060}	125	110	82	25	75	11	1.1	0.6	55 000	104 000	5 600	10 600	138 000	435 000	14 100	44 500		
70	70 ^{+0.090} _{+0.060}	130	115	82	25	80	11	1.1	0.6	57 000	119 000	5 800	12 200	142 000	460 000	14 500	47 000		

Note 1) Allowable minimum chamfer dimension r or r_1 .



Limiting dimensions r/min		Bearing numbers	Radial clearance μm		Abutment dimensions mm				Preload		Starting torque ²⁾		Mass
grease	oil		min	max	d_a min	D_a max	r_{as} max	r_{las} max	N	kgf	N·mm	kgf·mm	kg
1 800	7 000	ARN2052T2	10	30	39	46	0.6	0.6	2 500	250	430	43	0.440
1 500	6 000	ARN2062	10	30	48	56	1	0.6	4 950	495	1 150	115	0.910
1 500	6 000	ARN2557T2	10	30	44	51	0.6	0.6	2 600	260	500	50	0.560
1 200	4 900	ARN2572	10	40	56	66	1	0.6	5 050	505	1 400	140	1.22
1 400	5 500	ARN3062T2	10	40	49	56	0.6	0.6	2 900	290	650	65	0.630
1 100	4 400	ARN3080	10	40	63	73	1	0.6	6 900	690	2 100	210	1.54
1 200	4 800	ARN3570T2	10	40	56	64	1	0.6	3 950	395	1 050	105	0.850
1 000	4 100	ARN3585	10	40	68	77	1	0.6	7 600	760	2 500	250	1.67
1 100	4 400	ARN4075T2	10	40	61	69	1	0.6	4 200	420	1 250	125	0.930
950	3 800	ARN4090	10	40	73	87	1	0.6	7 850	785	2 850	285	2.15
1 000	4 000	ARN4580T2	10	40	66	74	1	0.6	4 450	445	1 550	155	1.16
850	3 300	ARN45105	15	50	83	96	1	0.6	11 200	1 120	4 350	435	3.16
900	3 600	ARN5090	15	50	75	83	1	0.6	5 800	580	2 050	205	1.48
800	3 100	ARN50110	15	50	88	101	1	0.6	11 600	1 160	4 900	490	3.38
750	2 900	ARN55115	15	50	93	106	1	0.6	12 000	1 200	5 500	550	3.61
700	2 700	ARN60120	15	50	98	111	1	0.6	12 400	1 240	6 000	600	3.81
650	2 600	ARN65125	15	50	103	116	1	0.6	12 800	1 280	6 500	650	4.00
650	2 500	ARN70130	15	50	106	121	1	0.6	13 200	1 320	7 000	700	4.25

Note 2) Starting torque subject to standard preload.

Roller Followers / Cam Followers



Roller Followers (Yoke Type Track Rollers)

NTN Yoke Type Track Rollers is the rolling mechanisms whose outer ring rolls on a track. For example, these track rollers are applied to eccentric roller, guide roller, rocker arm roller, cam roller and pressure roller. For that, the outer ring is designed to such a wall thickness as to be resistible to high load and shock load.

Both of spherical outer surface (rolling surface) and cylindrical outer surface are available for the outer ring. The spherical outer ring can damp edge-load acting on the contact surface between the track and the track roller, while the cylindrical outer ring (Tail code: **X**) has track load capacity greater than the spherical outer ring.

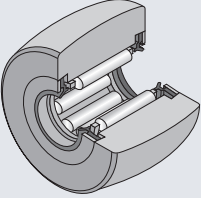
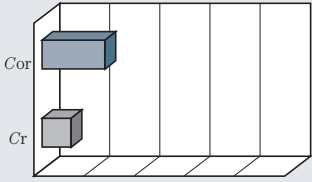
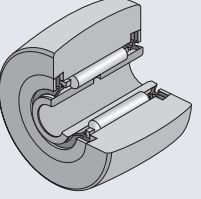
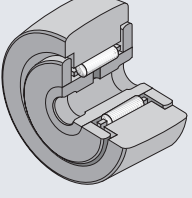
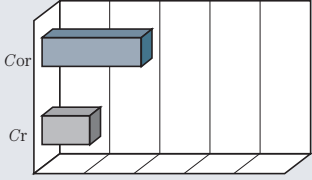
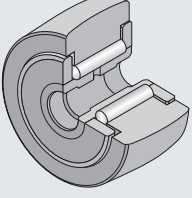
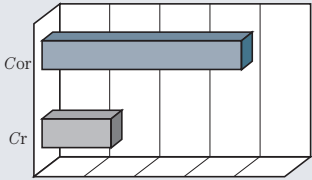
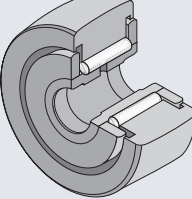
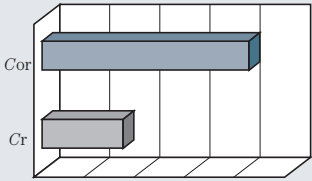
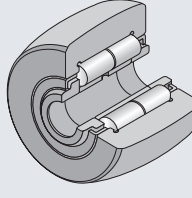
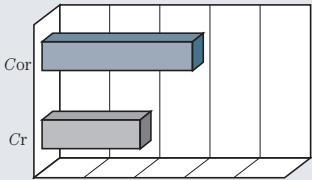
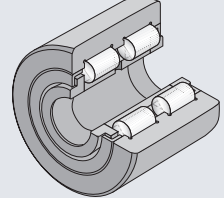
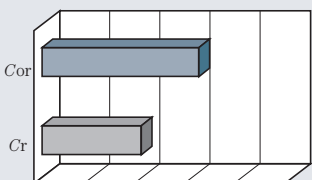
Bearing type	Applied shaft diameter (mm)	Load capacity	Composition of nominal bearing number
RNA22 	$\phi 6 \sim \phi 58$		RNA 22 / 6 LL Tail code LL: Seal Dimension code Dimension series code Type code
NA22 			NA 22 06 X LL Tail code LL: Seal Tail code X: Cylinder outer diameter Dimension code Dimension series code Type code
NATR 	$\phi 5 \sim \phi 50$		NATR 30 X LL Tail code LL: Seal Tail code X: Cylinder outer diameter Dimension code Type code
NATV 	$\phi 5 \sim \phi 50$		NATV 25 LL Tail code LL: Seal Dimension code Type code
NACV 	$\phi 6.35 \sim \phi 57.15$		NACV 32 X LL Tail code LL: Seal Tail code X: Cylinder outer diameter Dimension code Type code
NUTR 	$\phi 15 \sim \phi 50$		NUTR 3 10 Dimension code Dimension series code Type code
NUTW 	$\phi 15 \sim \phi 50$		NUTW 2 05 X Tail code X: Cylinder outer diameter Dimension code Dimension series code Type code

Each listed load capacity is subject to reference bearing bore diameter of $\phi 50$ or $\phi 50.8$

Track roller components	Features
Inscribed circle diameter : $\phi 6$ Type with cage Inner ring : without Outer profile : spherical Seal : with	<ul style="list-style-type: none"> ● The needle rollers and the cage are retained in the outer ring with a steel plate reinforced synthetic rubber seal, and these are inseparable from each other. ● The needle rollers guided by cage. ● Shaft (Pin) must be provided with a thrust washer or a flange to guide the outer ring.
Inscribed circle diameter : $\phi 30$ Type with cage Inner ring : with Outer profile : cylindrical Seal : with	
Inscribed circle diameter : $\phi 30$ Type with cage Outer profile : cylindrical Seal : with	<ul style="list-style-type: none"> ● Needle rollers guided by cage. ● The outer ring is guided in axial direction by the thrust washer press-fitted in the inner ring. ● Labyrinth is formed between the outer ring and the thrust washer.
Inscribed circle diameter : $\phi 30$ Full complement roller type Outer profile : cylindrical Seal : with	<ul style="list-style-type: none"> ● The outer ring is guided in axial direction by the thrust washer press-fitted in the inner ring. ● Great rated load due to the full complement roller type. ● Lower allowable running speed than bearing with cage. ● Labyrinth is formed between the outer ring and the thrust washer.
Inscribed circle diameter : $\phi 15.875$ Full complement roller type Outer profile : cylindrical Seal : with	
Inscribed circle diameter : $\phi 50$ Double-row cylindrical Full-complement roller type Labyrinth seal Outer profile : spherical	<ul style="list-style-type: none"> ● Greater rated load, best-suited to applications subjected to high load and shock load. ● A steel plate is press-fitted in the outer ring to form labyrinth between the plate and the side plates at both sides of the inner ring, whereby the required sealing performance is secured and the side plates are held so as not to separate from one another. ● The inner ring and the side plates are tightened together in axial direction for non-clearance. ● The outer ring is guided in axial direction by the outer ring ribs and the end faces of cylindrical roller. Particularly Type NUTW provides the following features. <ul style="list-style-type: none"> ● The greatest rated load, of the roller followers. ● Due to the outer ring with inner ribs, this type is excellently resistible to axial load and moment load and, in addition, runs smoothly, though depending on actual operating conditions. ● Good lubrication effect and longer life are expectable by increasing the grease fill volume.
Inscribed circle diameter : $\phi 25$ Double-row cylindrical Full-complement roller type with center rib Labyrinth seal Outer profile : spherical	

Bearing Tolerances

The respective dimensional accuracy, profile accuracy and running accuracy of the bearing bore diameter (d), cylindrical roller outer diameter (D), and outer ring width (C) are as shown in **Table 4.3** of Section 4. "**Bearing Accuracy**" (page A-26). (Conforming to JIS Accuracy Class-0)

On the other hand, the dimensional tolerances for spherical roller outer diameter (D) and the roller inscribed circle diameter (F_w) of **Type RNA22** are as shown in applicable Dimensions Table.

Bearing fits and radial clearance

The tolerance range class of shaft against bearing with inner ring shall be g6 (h6) and, where a shaft is used as the direct raceway surface (**Type RNA22**), the tolerance range class of the shaft shall be k5 (k6). In general, the outer ring is not fitted in a housing. Mounting relations

Table 1 Radial clearances

Unit: μm

Nominal roller inscribed circle dia. F_w (mm)		Clearance							
		C2		Ordinary		C3		C4	
over	Incl.	min	max	min	max	min	max	min	max
3	6	0	10	3	17	15	30	20	40
6	10	0	12	5	20	15	30	25	45
10	18	0	15	5	25	15	35	30	55
18	30	0	20	10	30	20	40	40	65
30	50	0	25	10	40	25	55	50	80
50	80	0	30	15	50	30	65	60	100
80	100	0	35	20	55	35	75	70	115

(1) The side face height in the roller follower mount must be made larger than "e" dimension described in applicable Dimensions Table. (**Fig.1**) In mounting, chamfer the mounting surface at R as small as possible (around $0.5 \times 45^\circ$) and bring the inner ring and the end face of side plate in precise contact with one another.



Fig.1

(2) Where the roller follower is mounted, locate the inner ring oil hole within the non-load area (load free side). (**Fig. 2**)

If the oil hole locates within the load area, it would cause shorter life.

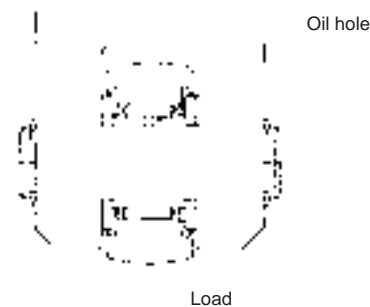

Fig.2

(3) **Type NA··22LL** and **RNA22** are of separable type and, hence, the outer ring is guided by flange or thrust washer mounted on shaft (pin). Therefore, the guide surface must be finished more precisely than by lathe-turning and deburred completely for surface smoothing. In addition, when the guide surface is not hardened the outer ring must be guided at A -dimension shown in **Fig.3**. When it is hardened, even a little smaller guide surface can be used.

$$A \geq \frac{1}{2}(D+e)$$

For D and e dimensions refer to applicable Dimensions Table.

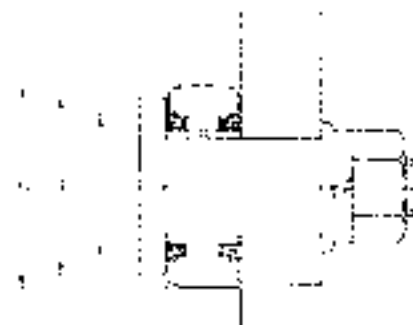

Fig.3

In assembling this bearing, it must be handled with good care to protect the seal lip from bending and flaw.

Where any of NTN roller followers was stub-mounted, non-uniform load (bias load) could act on the bearing, inversely affected by fitting loose arising from further continued running. Good care must be exercised of such fitting loose, for stable running of the equipment.

Lubrication

The roller followers with synthetic rubber seal (with tail code : **LL**) and the full complement roller type followers are filled up with lithium soap base grease so that they can be used in the temperature range of -25 to +100°C. Lubricant feeding and replenishing into the bearing are done through an oil hole provided on the inner ring. In this case, the inner ring must be fitted so the oil hole locates within non-load area. For the full complement roller type roller followers **NATV**, **NACV**, **NUTR** and **NUTW** with no cage, it is necessary to shorten the grease replenishing interval.

Further, a roller follower with cage and without seal is not filled up with lubrication grease. When needing a follower with grease-filled cage, feel free to contact **NTN**.

The outer ring outer surface of bearing and the track surface must both be lubricated. Failure to lubricate could result earlier in damage of the bearing.

Track load capacity

Statically allowable maximum radial load on the contact surface of track to track roller is referred to as "track load capacity", which differs depending on the track hardness. The track load capacity described in applicable Dimensions Table is subject to track hardness HRC40. If the hardness value is other than HRC40, multiply the track load capacity in the Dimensions Table by the adjustment factor *G* in **Table 2**, for determining the track load capacity. However, the track load capacity shall be C_{0r} if the calculated track load capacity exceeds the basic static load rating C_{0r} of bearing.

Refer to page A-55 for the detail.

Table 2 Adjustment factor *G*

Hardness HRC	Adjustment factor <i>G</i>	
	Cylindrical surface	Spherical surface
20	0.37	0.22
25	0.46	0.31
30	0.58	0.45
35	0.75	0.65
40	1.00	1.00
45	1.40	1.70
50	2.00	2.80
55	2.80	4.70

Metric series

Type NA22··LL

Type RNA22··LL

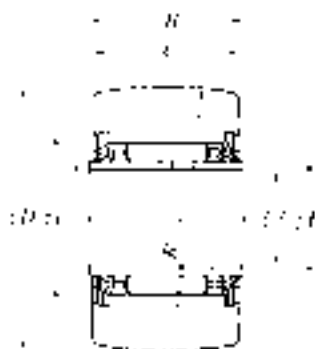
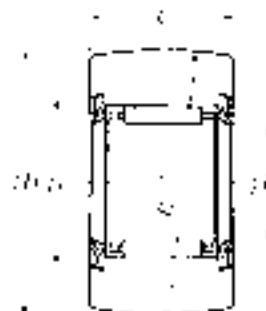
 Type NA22··LL
(With inner ring)

 Type RNA22··LL
(Without inner ring)

D 19~90mm

Boundary dimensions									Basic load ratings				Load ratings of truck			
D 0 -0.05	B	C	d	mm					dynamic	static	dynamic	static	N		kgf	
				F _w	e	F	r _s min ¹⁾	C _r	C _{or}	C _r	C _{or}	N	kgf			
19	12	11.8	6	10	+0.022 +0.013	16	10	0.3	4 550	4 250	460	435	1 380	4 400	141	445
24	12	11.8	8	12	+0.027 +0.016	18	12	0.3	5 150	5 250	525	535	1 900	5 500	193	565
30	14	13.8	10	14	+0.027 +0.016	20	14	0.3	7 550	9 000	770	915	2 620	7 550	267	770
32	14	13.8	12	16	+0.027 +0.016	22	16	0.3	8 100	10 300	830	1 050	2 860	8 050	291	820
35	14	13.8	15	20	+0.033 +0.020	26	20	0.3	9 850	14 100	1 010	1 440	3 200	8 800	325	900
40	16	15.8	17	22	+0.033 +0.020	28	22	0.3	10 400	15 600	1 060	1 590	3 850	10 900	390	1 110
47	18	17.8	20	25	+0.033 +0.020	33	25	0.3	16 900	22 900	1 730	2 340	4 700	14 800	480	1 510
52	18	17.8	25	30	+0.033 +0.025	38	30	0.3	17 900	25 900	1 820	2 640	5 550	16 400	565	1 670
62	20	19.8	30	35	+0.041 +0.025	43	35	0.3	21 400	34 500	2 190	3 500	6 950	22 200	710	2 260
72	23	22.7	35	42	+0.041 +0.025	50	42	0.6	26 300	47 500	2 690	4 850	8 050	28 700	820	2 930
80	23	22.7	40	48	+0.041 +0.025	57	48	0.6	28 400	55 000	2 900	5 600	9 800	32 000	1 000	3 250
85	23	22.7	45	52	+0.049 +0.030	62	52	0.6	29 300	58 500	2 990	5 950	10 400	34 000	1 060	3 450
90	23	22.7	50	58	+0.049 +0.030	68	58	0.6	31 000	66 000	3 200	6 700	11 400	36 000	1 160	3 650

 Note 1) Allowable minimum chamfer dimension r .

2) For bearing with cylindrical outer surface, the nominal bearing is followed by "X". In this case, the bearing is manufactured with outer ring diameter tolerance conforming to JIS Class-0. Ex. NA2203XLL

Roller followers : Yoke type truck rollers (sealed type)

Limiting speeds r/min grease	Bearing numbers		Mass (approx.) kg	
	Type NA22··LL ²⁾	Type RNA22··LL ²⁾	Type NA22··LL	Type RNA22··LL
10 000	NA22/6LL	RNA22/6LL	0.023	0.018
10 000	NA22/8LL	RNA22/8LL	0.035	0.027
10 000	NA2200LL	RNA2200LL	0.060	0.052
9 500	NA2201LL	RNA2201LL	0.067	0.057
7 500	NA2202LL	RNA2202LL	0.075	0.060
7 000	NA2203LL	RNA2203LL	0.113	0.094
6 000	NA2204LL	RNA2204LL	0.176	0.152
5 000	NA2205LL	RNA2205LL	0.209	0.179
4 300	NA2206LL	RNA2206LL	0.322	0.284
3 600	NA2207LL	RNA2207LL	0.506	0.432
3 100	NA2208LL	RNA2208LL	0.623	0.530
2 900	NA2209LL	RNA2209LL	0.638	0.545
2 600	NA2210LL	RNA2210LL	0.682	0.563

Metric series

- Type NATR
- Type NATR··LL
- Type NATV
- Type NATV··LL

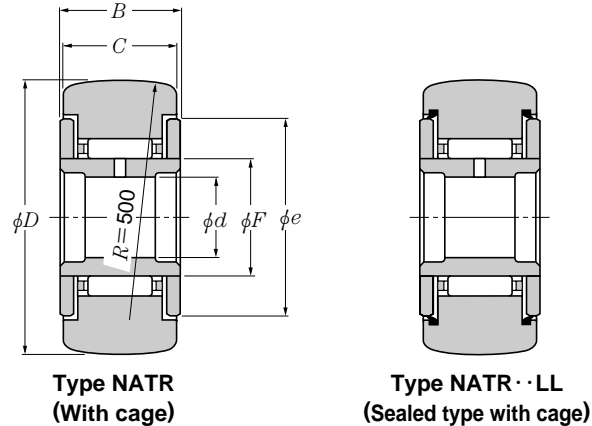

D 16~90mm

Boundary dimensions						Basic load ratings				Load ratings of truck				Limiting speeds		
D	B	mm		d	e	F _w	dynamic	static	dynamic	static	N		kgf		r/min	
		C	d				C _r	C _{or}	C _r	C _{or}	C _r	C _{or}	grease	oil		
16	12 ⁰ _{-0.05}	11	5	12	8		4 050	4 200	415	430	1 080	3 400	110	350	※19 000	※25 000
	12 ^{-0.180}	11	5	12	8		6 500	9 350	665	955	1 080	3 400	110	350	※13 000	※16 000
19	12 ⁰ _{-0.05}	11	6	14	10		4 750	5 400	480	555	1 380	4 050	141	415	※15 000	※20 000
	12 ^{-0.180}	11	6	14	10		7 450	11 700	760	1 190	1 380	4 050	141	415	10 000	※13 000
24	15 ⁰ _{-0.05}	14	8	19	12		6 900	7 700	705	785	1 900	6 650	193	680	※12 000	※16 000
	15 ^{-0.180}	14	8	19	12		10 700	16 200	1 090	1 650	1 900	6 650	193	680	8 500	※11 000
30	15 ⁰ _{-0.05}	14	10	23	15		7 850	9 650	800	985	2 620	7 700	267	785	10 000	※13 000
	15 ^{-0.180}	14	10	23	15		12 000	20 300	1 230	2 070	2 620	7 700	267	785	6 500	8 500
32	15 ⁰ _{-0.05}	14	12	25	17		8 850	11 700	900	1 190	2 860	8 200	291	835	9 000	※12 000
	15 ^{-0.180}	14	12	25	17		13 000	23 000	1 330	2 350	2 860	8 200	291	835	6 000	7 500
35	19 ⁰ _{-0.05}	18	15	27	20		13 300	20 800	1 360	2 120	3 200	11 900	325	1 220	7 500	10 000
	19 ^{-0.210}	18	15	27	20		18 400	38 000	1 870	3 900	3 200	11 900	325	1 220	5 000	6 500
40	21 ⁰ _{-0.05}	20	17	32	22		14 000	22 800	1 430	2 330	3 850	14 500	390	1 480	7 000	9 000
	21 ^{-0.210}	20	17	32	22		19 400	42 000	1 980	4 250	3 850	14 500	390	1 480	4 500	6 000
47	25 ⁰ _{-0.05}	24	20	37	25		20 700	33 500	2 110	3 450	4 700	21 000	480	2 150	6 000	8 000
	25 ^{-0.210}	24	20	37	25		28 800	61 000	2 940	6 250	4 700	21 000	480	2 150	4 000	5 000
52	25 ⁰ _{-0.05}	24	25	42	30		22 800	40 500	2 320	4 100	5 500	23 300	565	2 370	5 000	6 500
	25 ^{-0.210}	24	25	42	30		31 500	73 500	3 200	7 500	5 500	23 300	565	2 370	3 300	4 500
62	29 ⁰ _{-0.05}	28	30	51	38		36 000	66 000	3 650	6 750	6 950	33 000	710	3 350	4 000	5 500
	29 ^{-0.210}	28	30	51	38		47 500	115 000	4 850	11 700	6 950	33 000	710	3 350	2 600	3 500
72	29 ⁰ _{-0.05}	28	35	58	44.5		39 000	77 000	3 950	7 850	8 050	37 000	820	3 750	3 300	4 500
	29 ^{-0.210}	28	35	58	44.5		52 000	134 000	5 300	13 600	8 050	37 000	820	3 750	2 200	2 900
80	32 ⁰ _{-0.05}	30	40	66	50		49 500	92 500	5 050	9 400	9 800	44 500	1 000	4 500	3 000	4 000
	32 ^{-0.250}	30	40	66	50		68 500	171 000	7 000	17 500	9 800	44 500	1 000	4 500	2 000	2 600
85	32 ⁰ _{-0.250}	30	45	71	55		51 500	100 000	5 250	10 200	10 400	47 000	1 060	4 800	2 700	3 600
90	32 ⁰ _{-0.05}	30	50	76	60		53 000	108 000	5 450	11 000	11 400	50 000	1 160	5 100	2 500	3 300
	32 ^{-0.250}	30	50	76	60		76 000	205 000	7 750	20 900	11 400	50 000	1 160	5 100	1 600	2 100

Note 1) For bearing with cylindrical outer surface, the nominal bearing is followed by "X". In this case, the bearing is manufactured with outer ring diameter tolerance conforming to JIS Class-0. Ex. NATR5X

Remarks: For the follower with seal, the maximum revolutions is allowable up to 10 000 r/min.

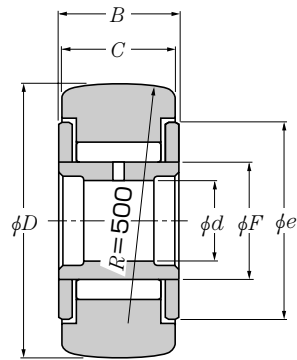

Type NATV
(Full complement type)

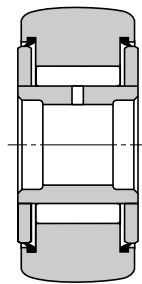

Type NATV··LL
(Full complement type with seals)

Bearing numbers ¹⁾		Mass
Type NATR	Type NATR··LL	kg
Type NATV	Type NATV··LL	(approx.)
NATR5	NATR5LL	0.018
NATV5	NATV5LL	0.020
NATR6	NATR6LL	0.025
NATV6	NATV6LL	0.027
NATR8	NATR8LL	0.042
NATV8	NATV8LL	0.044
NATR10	NATR10LL	0.061
NATV10	NATV10LL	0.065
NATR12	NATR12LL	0.069
NATV12	NATV12LL	0.074
NATR15	NATR15LL	0.098
NATV15	NATV15LL	0.102
NATR17	NATR17LL	0.140
NATV17	NATV17LL	0.145
NATR20	NATR20LL	0.246
NATV20	NATV20LL	0.254
NATR25	NATR25LL	0.275
NATV25	NATV25LL	0.285
NATR30	NATR30LL	0.470
NATV30	NATV30LL	0.481
NATR35	NATR35LL	0.635
NATV35	NATV35LL	0.647
NATR40	NATR40LL	0.875
NATV40	NATV40LL	0.890
NATR45	NATR45LL	0.910
NATR50	NATR50LL	0.960
NATV50	NATV50LL	0.990

Inch series

Type NACV···X

Type NACV···XLL

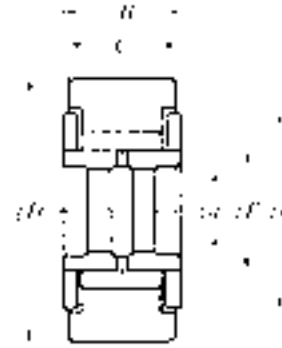

Type NACV···X
(Full complement)

D 19.050~152.400mm

Boundary dimensions							Basic load ratings			
D 0 -0.025	B 0 -0.250	C 0 -0.130	d	e	F_w	dynamic N	static	dynamic	static	
										mm ($\frac{1}{25.4}$ mm)
						C_r	C_{or}	C_r	C_{or}	
19.050($\frac{3}{4}$)	14.288($\frac{9}{16}$)	12.700($\frac{1}{2}$)	6.350($\frac{1}{4}$)	$\begin{matrix} +0.005 \\ -0.010 \end{matrix}$	15.5	11	8 050	13 300	825	1 360
22.225($\frac{7}{8}$)	14.288($\frac{9}{16}$)	12.700($\frac{1}{2}$)	6.350($\frac{1}{4}$)	$\begin{matrix} +0.005 \\ -0.010 \end{matrix}$	15.5	11	8 050	13 300	825	1 360
25.400(1)	17.462($1\frac{1}{16}$)	15.875($\frac{5}{8}$)	7.938($\frac{5}{16}$)	$\begin{matrix} +0.005 \\ -0.010 \end{matrix}$	19.5	14	11 700	18 900	1 190	1 920
28.575($1\frac{1}{8}$)	17.462($1\frac{1}{16}$)	15.875($\frac{5}{8}$)	7.938($\frac{5}{16}$)	$\begin{matrix} +0.005 \\ -0.010 \end{matrix}$	19.5	14	11 700	18 900	1 190	1 920
31.750($1\frac{1}{4}$)	20.638($1\frac{3}{16}$)	19.050($\frac{3}{4}$)	9.525($\frac{3}{8}$)	$\begin{matrix} +0.005 \\ -0.010 \end{matrix}$	25	18.47	17 700	35 000	1 810	3 600
34.925($1\frac{3}{8}$)	20.638($1\frac{3}{16}$)	19.050($\frac{3}{4}$)	9.525($\frac{3}{8}$)	$\begin{matrix} +0.005 \\ -0.010 \end{matrix}$	25	18.47	17 700	35 000	1 810	3 600
38.100($1\frac{1}{2}$)	23.812($1\frac{5}{16}$)	22.225($\frac{7}{8}$)	11.112($\frac{7}{16}$)	$\begin{matrix} +0.005 \\ -0.010 \end{matrix}$	27	21	21 100	45 500	2 150	4 650
41.275($1\frac{5}{8}$)	23.812($1\frac{5}{16}$)	22.225($\frac{7}{8}$)	11.112($\frac{7}{16}$)	$\begin{matrix} +0.005 \\ -0.010 \end{matrix}$	27	21	21 100	45 500	2 150	4 650
44.450($1\frac{3}{4}$)	26.988($1\frac{1}{16}$)	25.400(1)	12.700($\frac{1}{2}$)	$\begin{matrix} +0.005 \\ -0.010 \end{matrix}$	31.5	24.65	28 400	60 500	2 900	6 150
47.625($1\frac{7}{8}$)	26.988($1\frac{1}{16}$)	25.400(1)	12.700($\frac{1}{2}$)	$\begin{matrix} +0.005 \\ -0.010 \end{matrix}$	31.5	24.65	28 400	60 500	2 900	6 150
50.800(2)	33.338($1\frac{5}{16}$)	31.750($1\frac{1}{4}$)	15.875($\frac{5}{8}$)	$\begin{matrix} +0.005 \\ -0.010 \end{matrix}$	36.5	26.71	41 000	87 500	4 200	8 950
57.150($2\frac{1}{4}$)	33.338($1\frac{5}{16}$)	31.750($1\frac{1}{4}$)	15.875($\frac{5}{8}$)	$\begin{matrix} +0.005 \\ -0.010 \end{matrix}$	36.5	26.71	41 000	87 500	4 200	8 950
63.500($2\frac{1}{2}$)	39.688($1\frac{9}{16}$)	38.100($1\frac{1}{2}$)	19.050($\frac{3}{4}$)	$\begin{matrix} +0.005 \\ -0.010 \end{matrix}$	44	31.15	54 500	119 000	5 600	12 200
69.850($2\frac{3}{4}$)	39.688($1\frac{9}{16}$)	38.100($1\frac{1}{2}$)	19.050($\frac{3}{4}$)	$\begin{matrix} +0.005 \\ -0.010 \end{matrix}$	44	31.15	54 500	119 000	5 600	12 200
76.200(3)	46.038($1\frac{13}{16}$)	44.450($1\frac{3}{4}$)	25.400(1)	$\begin{matrix} +0.002 \\ -0.013 \end{matrix}$	53	36.85	76 500	177 000	7 800	18 000
82.550($3\frac{1}{4}$)	46.038($1\frac{13}{16}$)	44.450($1\frac{3}{4}$)	25.400(1)	$\begin{matrix} +0.002 \\ -0.013 \end{matrix}$	53	36.85	76 500	177 000	7 800	18 000
88.900($3\frac{1}{2}$)	52.388($2\frac{1}{16}$)	50.800(2)	28.575($1\frac{1}{8}$)	$\begin{matrix} +0.002 \\ -0.013 \end{matrix}$	60	44.5	84 500	214 000	8 650	21 800
101.600(4)	58.738($2\frac{5}{16}$)	57.150($2\frac{1}{4}$)	31.750($1\frac{1}{4}$)	$\begin{matrix} +0.002 \\ -0.013 \end{matrix}$	63	44.5	106 000	244 000	10 800	24 900
127.000(5)	73.025($2\frac{7}{8}$)	69.850($2\frac{3}{4}$)	44.450($1\frac{3}{4}$)	$\begin{matrix} +0.002 \\ -0.013 \end{matrix}$	89	68.7	189 000	520 000	19 300	53 000
152.400(6)	85.725($3\frac{3}{8}$)	82.550($3\frac{1}{4}$)	57.150($2\frac{1}{4}$)	$\begin{matrix} +0.002 \\ -0.013 \end{matrix}$	110	81.35	260 000	675 000	26 500	68 500

Note 1) For the bearing with spherical outer surface, "X" symbol shall be deleted from the Nominal number. In this case, spherical bearing ($R=500$) is manufactured with tolerance $0/-0.05$ against the outer ring outer diameter "D". Ex. NACV12

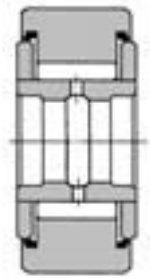

Type NACV··XLL
(Full complement sealed type)

Load ratings of truck				Limiting speeds		Bearing numbers		Mass
N	kgf			r/min		Type NACV··X ¹⁾	Type NACV··XLL ¹⁾	(approx.) kg Type NACV··X
				grease	oil			
4 600	1 380	470	140	9 000	※11 000	NACV12X	NACV12XLL	0.027
5 350	1 710	545	174	9 000	※11 000	NACV14X	NACV14XLL	0.036
7 400	2 060	755	210	7 100	9 200	NACV16X	NACV16XLL	0.059
8 350	2 430	850	248	7 100	9 200	NACV18X	NACV18XLL	0.073
11 400	2 840	1 160	290	5 400	7 000	NACV20X	NACV20XLL	0.109
12 500	3 250	1 280	330	5 400	7 000	NACV22X	NACV22XLL	0.132
16 300	3 600	1 660	365	4 800	6 200	NACV24X	NACV24XLL	0.177
17 600	4 050	1 800	410	4 800	6 200	NACV26X	NACV26XLL	0.218
21 600	4 400	2 200	450	4 100	5 300	NACV28X	NACV28XLL	0.281
23 200	4 850	2 360	495	4 100	5 300	NACV30X	NACV30XLL	0.327
31 000	5 300	3 150	540	3 700	4 800	NACV32X	NACV32XLL	0.454
35 000	6 200	3 550	635	3 700	4 800	NACV36X	NACV36XLL	0.585
44 500	7 200	4 550	735	3 200	4 100	NACV40X	NACV40XLL	0.902
49 000	8 250	5 000	840	3 200	4 100	NACV44X	NACV44XLL	1.05
64 000	9 150	6 500	935	2 700	3 500	NACV48X	NACV48XLL	1.39
69 000	10 000	7 050	1 020	2 700	3 500	NACV52X	NACV52XLL	1.66
86 000	11 100	8 800	1 130	2 200	2 800	NACV56X	NACV56XLL	2.19
112 500	13 200	11 500	1 350	2 200	2 800	NACV64X	NACV64XLL	3.22
165 500	17 900	16 900	1 830	1 500	1 900	NACV80X	NACV80XLL	6.08
239 500	22 100	24 400	2 250	1 200	1 500	NACV96X	NACV96XLL	10.0

Remarks: For the follower with seal, the maximum revolutions is allowable up to 10 000 r/min.

Metric series

Type NUTR2

Type NUTR3

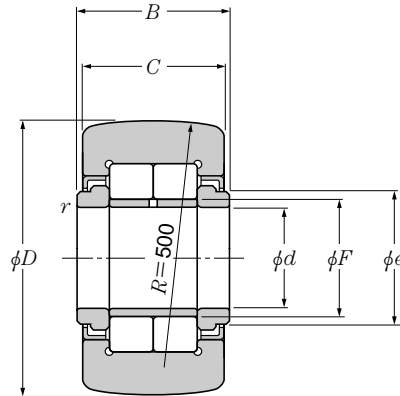

D 35~110mm

Boundary dimensions mm							Basic load ratings				Load ratings of truck				Limiting speeds r/min grease	Bearing ²⁾ numbers	Mass kg (approx.)
D	B	C	d	e	F _w	r _{3 min 1)}	dynamic N	static	dynamic kgf	static	N	kgf	N	kgf			
$0_{-0.05}$							C _r	C _{or}	C _r	C _{or}							
35	19 $^0_{-0.210}$	18	15	20	19	0.3	22 300	25 700	2 280	2 620	3 200	11 900	325	1 220	5 500	NUTR202	0.100
40	21 $^0_{-0.210}$	20	17	22	21.5	0.3	24 100	29 100	2 450	2 970	3 850	14 500	390	1 480	4 700	NUTR203	0.147
42	19 $^0_{-0.210}$	18	15	20	19	0.3	22 300	25 700	2 280	2 620	4 100	14 300	415	1 460	5 500	NUTR302	0.160
47	21 $^0_{-0.210}$	20	17	22	21.5	0.3	24 100	29 100	2 450	2 970	4 700	17 000	480	1 740	4 700	NUTR303	0.222
	25 $^0_{-0.210}$	24	20	27	25.5	0.3	38 500	48 000	3 950	4 900	4 700	21 000	480	2 150	4 000	NUTR204	0.245
52	25 $^0_{-0.210}$	24	20	27	25.5	0.3	38 500	48 000	3 950	4 900	5 550	23 300	565	2 370	4 000	NUTR304	0.321
	25 $^0_{-0.210}$	24	25	31	30	0.3	42 500	57 500	4 350	5 850	5 550	23 300	565	2 370	3 300	NUTR205	0.281
62	25 $^0_{-0.210}$	24	25	31	30	0.3	42 500	57 500	4 350	5 850	6 950	27 800	710	2 830	3 300	NUTR305	0.450
	29 $^0_{-0.210}$	28	30	38	35	0.3	56 500	72 500	5 750	7 400	6 950	33 000	710	3 350	2 900	NUTR206	0.466
72	29 $^0_{-0.210}$	28	30	38	35	0.3	56 500	72 500	5 750	7 400	8 050	38 500	820	3 900	2 900	NUTR306	0.697
	29 $^0_{-0.210}$	28	35	44	41.5	0.6	62 000	85 500	6 350	8 700	8 050	37 000	820	3 750	2 400	NUTR207	0.630
80	29 $^0_{-0.210}$	28	35	44	41.5	0.6	62 000	85 500	6 350	8 700	9 800	41 000	1 000	4 150	2 400	NUTR307	0.840
	32 $^0_{-0.250}$	30	40	51	47.5	0.6	87 000	125 000	8 850	12 700	9 800	44 500	1 000	4 500	2 100	NUTR208	0.817
85	32 $^0_{-0.250}$	30	45	55	52.5	0.6	92 000	137 000	9 350	14 000	10 400	47 000	1 060	4 800	1 900	NUTR209	0.883
90	32 $^0_{-0.250}$	30	40	51	47.5	0.6	87 000	125 000	8 850	12 700	11 400	50 000	1 160	5 100	2 100	NUTR308	1.13
	32 $^0_{-0.250}$	30	50	60	57	0.6	96 500	150 000	9 800	15 300	11 400	50 000	1 160	5 100	1 800	NUTR210	0.950
100	32 $^0_{-0.250}$	30	45	55	52.5	0.6	92 000	137 000	9 350	14 000	13 000	55 500	1 330	5 650	1 900	NUTR309	1.40
110	32 $^0_{-0.250}$	30	50	60	57	0.6	96 500	150 000	9 800	15 300	14 700	61 000	1 500	6 200	1 800	NUTR310	1.69

Note 1) Allowable minimum chamfer dimension r.

2) For bearing with cylindrical outer surface, the nominal bearing is followed by "X". In this case, the bearing is manufactured with outer ring diameter tolerance conforming to JIS Class-0. Ex. **NUTR208X**

Metric series

Type NUTW2

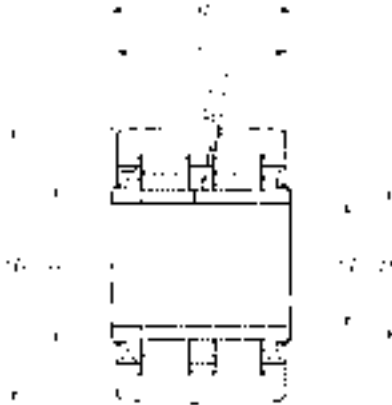

D 35~90mm

Boundary dimensions mm								Basic load ratings				Load ratings of truck				Limiting speeds r/min grease	Bearing ²⁾ numbers	Mass kg (approx.)
<i>D</i>	<i>B</i>	<i>C</i>	<i>d</i>	<i>e</i>	<i>F_w</i>	<i>r_s</i> (min 1)	dynamic N	static N	dynamic kgf	static kgf	N		kgf					
$0_{-0.05}$							<i>C_r</i>	<i>C_{or}</i>	<i>C_r</i>	<i>C_{or}</i>								
35	22 $^0_{-0.210}$	21	15	20	19	0.3	24 100	28 300	2 460	2 880	3 200	14 200	325	1 450	5 500	NUTW202	0.115	
40	24 $^0_{-0.210}$	23	17	22	21.5	0.3	26 000	32 000	2 650	3 250	3 850	17 100	390	1 740	4 700	NUTW203	0.167	
47	29 $^0_{-0.210}$	28	20	27	25.5	0.3	40 500	51 500	4 150	5 250	4 700	25 100	480	2 560	4 000	NUTW204	0.280	
52	29 $^0_{-0.210}$	28	25	31	30	0.3	45 000	61 500	4 600	6 250	5 550	27 700	565	2 830	3 300	NUTW205	0.322	
62	35 $^0_{-0.210}$	34	30	38	35	0.3	59 500	77 000	6 050	7 900	6 950	41 000	710	4 200	2 900	NUTW206	0.549	
72	35 $^0_{-0.210}$	34	35	44	41.5	0.6	65 000	91 000	6 650	9 250	8 050	46 000	820	4 700	2 400	NUTW207	0.747	
80	38 $^0_{-0.250}$	36	40	51	47.5	0.6	90 500	131 000	9 250	13 400	9 800	54 500	1 000	5 550	2 100	NUTW208	0.953	
85	38 $^0_{-0.250}$	36	45	55	52.5	0.6	95 500	144 000	9 750	14 700	10 400	58 000	1 060	5 900	1 900	NUTW209	1.03	
90	38 $^0_{-0.250}$	36	50	60	57	0.6	100 000	158 000	10 200	16 100	11 400	61 500	1 160	6 250	1 800	NUTW210	1.11	

Cam Followers (Stud Type Track Roller)

This is a track roller complete with stud instead of inner ring, which of the outer ring rolls on the track. These NTN stud type track rollers are applied to eccentric roller, guide roller, rocker arm roller, etc. similarly to the roller followers. One end of the stud is so threaded as to facilitate mounting thereof. And the outer ring is guided in

axial direction by the side plates which are press-fitted in the flange end of the stud and the stud itself.

The outer ring has a thick wall and both of spherical outer profile and cylindrical outer surface (tail code: X) are available for it similarly to the outer ring of the roller follower.

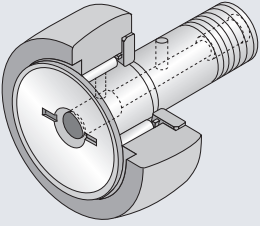
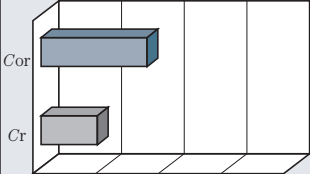
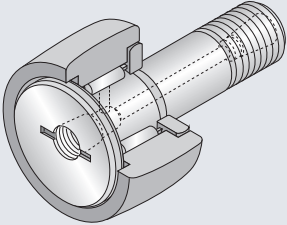
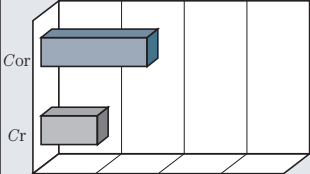
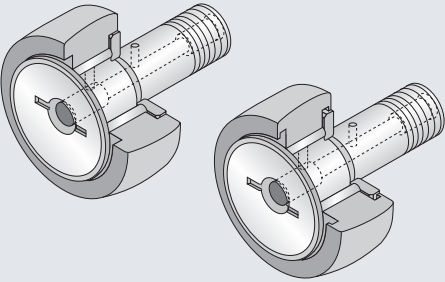
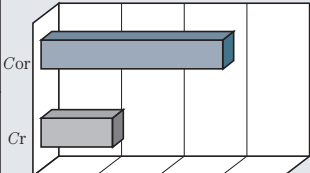
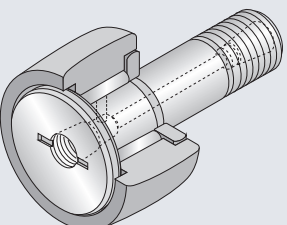
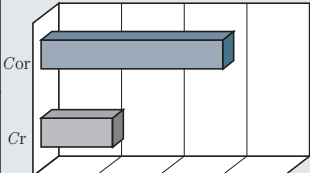
Follower type	Applied shaft diameter (mm)	Load capacity	Composition of nominal bearing number
<p>KR CR</p> 	<p>KR : $\phi 3 \sim \phi 30$</p> <p>CR : $\phi 4.826 \sim \phi 22.225$</p>	 <p>Cor</p> <p>Cr</p>	<p>KR 12 T2 H / 3A</p> <ul style="list-style-type: none"> — Tailed code — T2: Resin cage — H: With hexagon hole — 3A: grease — Dimension code — Type code
<p>KRT</p> 	<p>$\phi 6 \sim \phi 30$</p>	 <p>KR90</p>	<p>KRT 32 X LL</p> <ul style="list-style-type: none"> — Tail code — LL: Seal — Tailed code — X: Cylinder outer diameter — Dimension code — Type code
<p>KRV CRV</p> 	<p>KRV : $\phi 3 \sim \phi 30$</p> <p>CRV : $\phi 4.826 \sim \phi 63.5$</p>	 <p>Cor</p> <p>Cr</p>	<p>CRV 30 X LL</p> <ul style="list-style-type: none"> — Tail code — LL: Seal — Tailed code — X: Cylinder outer diameter — Dimension code — Type code
<p>KRVT</p> 	<p>$\phi 6 \sim \phi 30$</p>	 <p>KRV90</p>	<p>KRVT 52 X LL</p> <ul style="list-style-type: none"> — Tail code — LL: Seal — Tailed code — X: Cylinder outer diameter — Dimension code — Type code

※Each listed load capacity is subject to the reference bearing diameter of $\phi 30$.

Follower components	Features
<p>Outer ring outer diameter : ϕ 12 With metric series cage Without seal Outer profile : spherical Stud head : with hexagon hole Cage : resin cage Grease : already filled</p>	<ul style="list-style-type: none"> ● Standard cage is of steel plate punched type. ● Polyamide resin cage (Tail code: T2) can be used, too. Allowable temperature: 120°C Continuous operating temperature: 100°C or less ● Suited to high speed. ● Due to much filled grease, these types can be used for a long time without additional greasing though actual operating conditions.
<p>Outer ring outer diameter : ϕ 32 With metric series cage Stud head : with recessed slot for screwdriver use and tapped hole Outer surface profile : cylindrical Seal : with Grease : already filled.</p>	<ul style="list-style-type: none"> ● The standard follower of Type KRT has no hexagon hole (tail code: H), but with a threaded plug with hexagon socket as standard. ● The follower with neither seal nor grease code as tail code is of grease non-filled type.
<p>Outer ring outer diameter : ϕ 47.825 Inch series full-complement roller type Stud head : with recessed slot for screwdriver use Outer surface profile : cylindrical Seal : with Grease : already filled.</p>	<ul style="list-style-type: none"> ● Suited to high load. ● Lower allowable running speed than the type with cage. ● Grease replenishing interval must be shortened due to the small spacing volume.
<p>Outer ring outer diameter : ϕ 32 With metric series cage Stud head : With recessed slot for screwdriver use and tapped hole Outer surface profile : cylindrical Seal : with Grease : already filled.</p>	<ul style="list-style-type: none"> ● The standard follower of Type KRVT has no hexagon hole (tail code H), but with a threaded plug with hexagon socket as standard.

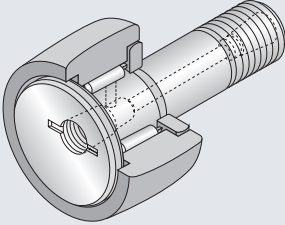
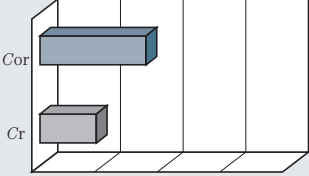
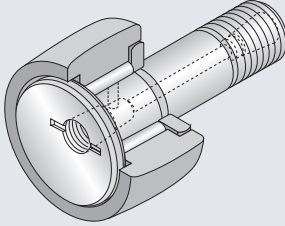
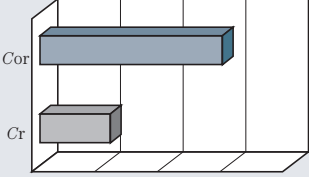
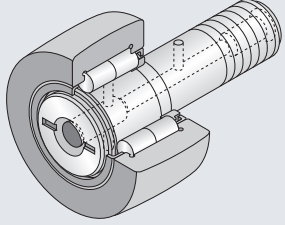
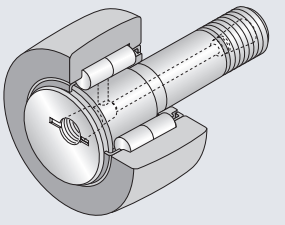
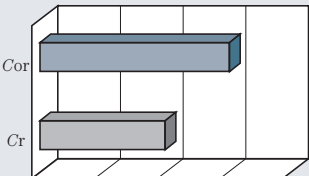
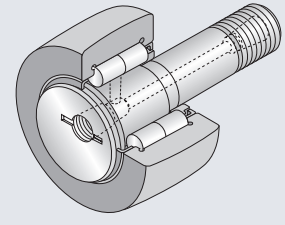
Follower type	Applied shaft diameter (mm)	Load capacity	Composition of nominal bearing number
<p>KRU</p> 	<p>$\phi 6 \sim \phi 30$</p>	 <p>KRU90</p>	<p>KRU 32 LL</p> <ul style="list-style-type: none"> — Tail code — LL: seal — Dimension code — Type code
<p>KRVU</p> 	<p>$\phi 6 \sim \phi 30$</p>	 <p>KRVU90</p>	<p>KRVU 62 X LL</p> <ul style="list-style-type: none"> — Tail code — LL: seal — Tail code — X: Cylinder outer diameter — Dimension code — Type code
<p>NUKR</p> 	<p>$\phi 12 \sim \phi 64$</p>		<p>NUKR 80 H</p> <ul style="list-style-type: none"> — Tail code — H: with hexagon socket — Dimension code — Type code
<p>NUKRT</p> 	<p>$\phi 12 \sim \phi 64$</p>	 <p>NUKR90</p>	<p>NUKRT 90</p> <ul style="list-style-type: none"> — Dimension code — Type code
<p>NUKRU</p> 	<p>$\phi 12 \sim \phi 64$</p>		<p>NUKRU 140 X</p> <ul style="list-style-type: none"> — Tail code — X: Cylinder outer diameter — Dimension code — Dimension code

※ Each listed load capacity is subject to the reference bearing diameter of $\phi 30$.

Follower components	Features
<p>Outer ring outer diameter: $\phi 32$ Metric series stud with cage, eccentric type Stud head : with recessed slot for screwdriver use and tapped hole Outer profile: spherical Seal : with Grease : already filled</p>	<ul style="list-style-type: none"> ● Unlike Type KRT and KRVT, Type KRU and KRVU have the eccentric stud (eccentricity : 0.25 to 1.0mm) so as to enable to adjust positional variation of the stud mounting hole. ● The standard follower has no hexagon hole (tail code H), but with a threaded plug with hexagon socket as standard. ● Type KRU --without seal. In addition, the same follower with no grease code is of grease non-filled type.
<p>Outer ring outer diameter: $\phi 62$ Metric series stud with cage, eccentric type Stud head : Metric series full-complement roller type stud, eccentric type Seal : with Outer profile: cylindrical Grease : already filled</p>	
<p>Outer ring outer diameter: $\phi 80$ Metric series double-row cylindrical roller type Shielded full-complement roller type Stud head : with hexagon socket Seal : with Outer profile: spherical Grease : already filled</p>	<ul style="list-style-type: none"> ● Highest rated load, best-suited to applications subjected to high load and shock load. ● The outer ring is guided in axial direction by the outer ring ribs and the end faces of cylindrical roller. ● Grease replenishing interval must be shortened due to the small spacing volume. ● Type NUKRU has the eccentric stud (eccentricity: 0.4 to 2.5mm) so as to enable to adjust positional variation of the stud mounting hole. ● The standard followers of Type NUKRT and NUKRU have no hexagon hole (tail code H), but with a threaded plug with hexagon socket as standard.
<p>Outer ring outer diameter: $\phi 90$ Metric series double-row cylindrical roller type Shielded full-complement roller type Stud head : with recessed slot for screwdriver use and tapped hole Outer profile: spherical Grease : already filled</p>	
<p>Outer ring outer diameter: $\phi 140$ Metric series double-row cylindrical roller type Shielded full-complement roller type stud, eccentric type Stud head : with recessed slot for screwdriver use and tapped hole Outer profile: cylindrical Grease : already filled</p>	

Bearing accuracy

The dimensional accuracy and profile accuracy of cylindrical roller outer diameter (D) and outer ring width (C), and the running accuracy of bearing assy are as shown in **Tables 4.3** and 4.4 of Section 4 "Bearing Tolerances" (page A-26) and the accuracy class of each conforms to JIS Class-0. The dimensional accuracy of spherical outer diameter (D) and stud diameter (d_1) are as shown in applicable Dimensions Table.

Bearing fit and radial internal clearance

Table 1 shows the recommended fitting tolerance for the stud mounting hole.

And **Table 2** shows the radial internal clearance.

Table 1 Recommended tolerance

Classification	Tolerance range class for mounting hole
Metric series	H7
Inch series	F7

Table 2 Radial internal clearance

Unit: μm

Nominal roller inscribed circle diameter F_w (mm)		Clearance							
		C2		CN (ordinary)		C3		C4	
over	incl.	min	max	min	max	min	max	min	max
3	6	0	10	3	17	15	30	20	40
6	10	0	12	5	20	15	30	25	45
10	18	0	15	5	25	15	35	30	55
18	30	0	20	10	30	20	40	40	65
30	50	0	25	10	40	25	55	50	80
50	80	0	30	15	50	30	65	60	100
80	100	0	35	20	55	35	75	70	115

Note) When shock load acts on, make the stud - hole clearance as less as possible in assembling.

Fitting relations

- (1) Make the face height at the cam follower mount greater than "e" dimension given in applicable Dimension Table. (**Fig.1**)
Furthermore, chamfer the stud mounting hole at R as small as possible (around $0.5 \times 45^\circ$) and bring the side faces of side face in precise contact.

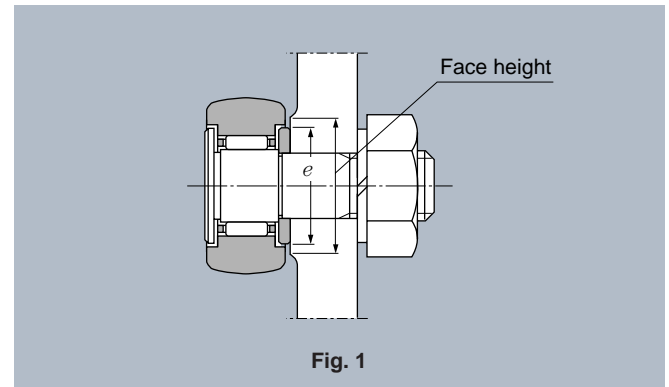

Fig. 1

- (2) Don't hammer directly the cam follower rib. Doing so would cause breakdown and rotation failure of the rib.

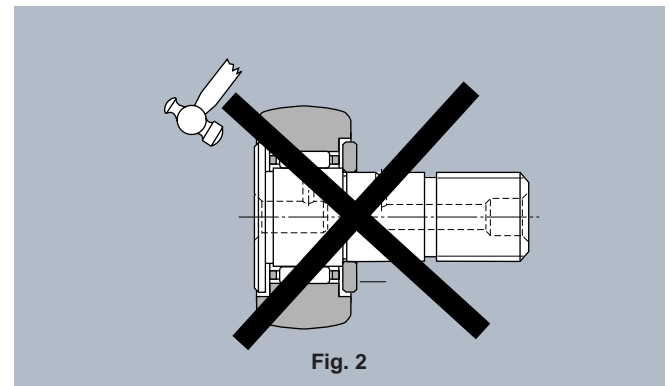

Fig. 2

- (3) The oil hole position on the stud raceway surface is shown with NTN mark stamped on the stud rib surface. Mount the stud so the oil hole locates within the non-load area (non-load side). (**Fig. 3**) If the oil hole locates within the load area, it would cause shorter life of the follower.

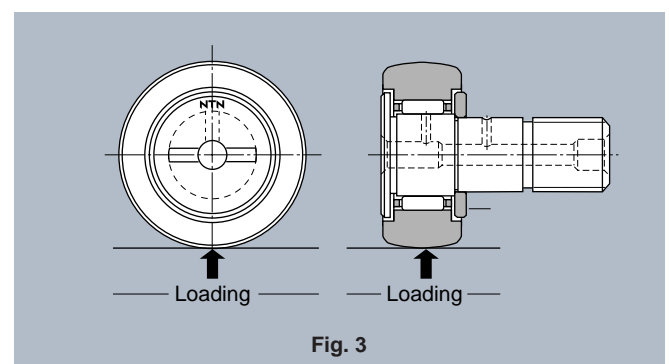
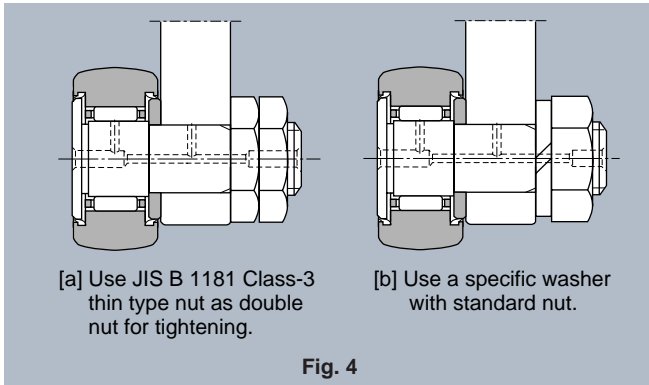
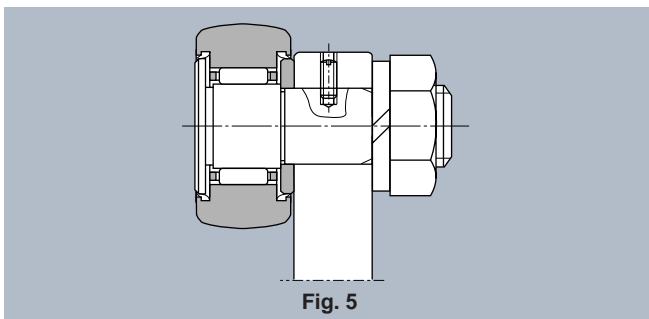

Fig. 3

- (4) Particularly where loose of the mounting screw is forecast due to wide amplitude vibration during running, the mounting methods as illustrated in **Fig. 4** are available.



- (5) The stud is subjected to bending stress and tensile force arising from bearing load. Tighten the stud screws with tightening torque which does not exceed the torque value specified in applicable Dimension Table. **Too tight tightening torque could result in rupture of the threaded portion.**
- (6) A hole is provided on the stud center at right angle to the shaft axial center, as illustrated in **Fig. 5**. Use this hole for locking or grease replenishment.



- (7) For mounting and adjusting the eccentric stud type cam follower, follow the sequence given hereunder.
1. Insert the stud in the mounting hole so that the **NTN** mark (showing oil hole position) locates in relative to load acting direction as illustrated in **Fig. 3**.
 2. Turn the stud using the recessed slot for screwdriver on the stud head or the accessory threaded plug with hexagon socket, to adjust a clearance from the mating contact surface.
 3. After adjustment, tighten the stud nut with specific tightening torque described in applicable Dimensions Table.

NTN cam follower is generally stud-mounted so that non-uniform load (bias load) could act on the bearing, inversely affected by fitting loose arising from continuous running. So, good care must be exercised of fitting loose for stable running of an equipment.

Lubrication and how to feed and replenish grease into the follower

Lubrication

The cam follower type with synthetic rubber seal (with tail code LL) and the full-complement roller type are pre-filled up with lithium soap base grease so they can be used in the operating temperature range of -25 to +100°C.

The type with cage and with no seal is not filled up with grease. If a grease pre-filled type is needed, feel free to contact NTN.

Further, NTN Bearings with Solid Dreeze using solid lubricant of less leakage is also available on request. Feel free to contact NTN for the detailed information.

The outer ring outer surface of bearing and the track surface must both be lubricated. Failure to lubricate could result earlier in damage of bearing.

How to feed and replenish grease

Feed and replenish grease through a grease nipple provided on the flange end face or threaded-side end face of the stud. In this case, plug the grease-feed hole or the tapped hole at non-greasing side (with a special-purposed plug or a threaded plug with hexagon socket.)

These grease nipple and plug are enclosed in each cam follower package. Screw-in them in specific position before mounting the cam follower.

Special grease nipple and that specified in JIS Standard as applicable are available for use. The dimensions thereof and the applicable bearing types are as specified in **Tables 3** and **4** respectively.

Furthermore, special press-fit type plug and threaded plug with hexagon socket are available for use. The dimensions thereof and the applicable bearing types are as specified in **Tables 5-1, -2** and **Table 6** respectively.

When using the special-purposed press-fit plug, press-fit it in the grease feed hole using a mandrel of applicable dimension shown in **Table 7**.

Table 3 Grease nipple dimension

Nominal nipple number	Dimension mm			
	d	D	L	L ₁
NIP-B3	3	7.5	9	5.5
NIP-B4	4	7.5	10	5.5
NIP-B6	6	8	13	6
NIP-B8	8	10	16	7

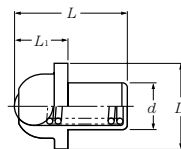

Nominal nipple number	Dimension mm				
	d	H	ℓ	L	B
NIP-X30	M4×0.7	13.9	4	5	7
JIS A-M6F	M6×0.75	13.5	4	5.4	7
JIS A-PT1/8	PT1/8	20	8	9.5	10

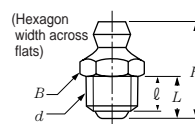

Table 4 Grease nipple applied bearing types and grease nipple dimension codes

Nominal nipple number	Nipple applied bearing types									
	KR, KRV	KR·H, KRV·H	CRV	CRV·H	NUKR	NUKR·H	KRT, KRVT	NUKRT	KRU, KRUV	NUKRU
NIP-B3	—	—	8.8-1	—	—	—	—	—	—	—
NIP-B4	16~26	22~26	10~18	12~18	—	—	—	—	—	—
NIP-B6	30~40	30~40	20~44	20~44	30~40	30~40	—	—	—	—
NIP-B8	47~90	47~90	48~96	48~96	47~90	47~90	—	—	—	—
NIP-X30	—	—	—	—	—	—	16~26	—	16~26	—
JIS A-M6F	—	—	—	—	—	—	30~32	30	30~35	30~35
JIS A-PT1/8	—	—	—	—	100~180 (Threaded side)	100~180	35~90	35~180	40~90	40~180

Table 5-1 Plug dimension

unit : mm

Nominal number	D	H
SEN 3	3	3
SEN 4	4	4
SEN 6	6	6
SEN 8	8	8

Special-purposed plug

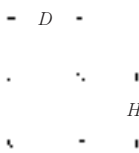

Threaded plug with hexagon socket



Table 5-2 Plug dimension

unit : mm

Nominal number	d	H	Width across flats h
M4X0.7X4 ℓ	M4X0.7	4	2
M6X0.75X6 ℓ	M6X0.75	6	3
PT1/8X7 ℓ	PT1/8	7	5

Table 6 Plug applied bearing types and plug dimension codes

Plug	Plug applied bearing types									
	KR, KRV	KR·H, KRV·H	CRV	CRV·H	NUKR	NUKR·H	KRT, KRVT	NUKRT	KRU, KRUV	NUKRU
SEN3	—	—	8.8-1	—	—	—	—	—	—	—
SEN4	16~26	22~26	10~18	12~18	—	—	—	—	—	—
SEN6	30~40	30~40	20~44	20~44	30~40	30~40	—	—	—	—
SEN8	47~90	47~90	48~96	48~96	47~180	47~90	—	—	—	—
M4X0.7X4 ℓ	—	—	—	—	—	—	16~26	—	16~26	—
M6X0.75X6 ℓ	—	—	—	—	—	—	30~32	30	30~35	30~35
PT1/8X7 ℓ	—	—	—	—	—	100~180	35~90	35~180	40~90	40~180

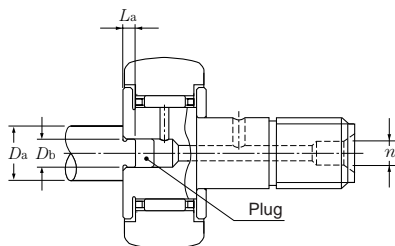

Table 7 Mandrels used for plug press-fitting

unit : mm

Grease feed hole dia. n	Mandrel dimension		
	Da	Db ⁰ _{-0.1}	La ⁰ _{-0.1}
3	8	2.8	1.5
4	10	3.8	1.5
6	12	5.8	1.5
8	15	7.8	2.5

Track load capacity

Maximum radial load which is statically allowable on the track roller to track contact surface is referred to as "track load capacity", and the track load capacity subject to track surface hardness HRC40 is as described in applicable Dimensions Table.

Where the track surface hardness is other than HRD40, adjust the track load capacity using the adjustment factor shown in **Table 11.1**.

Metric series

Type KR

Type KR··LL

Type KRV

Type KRV··LL

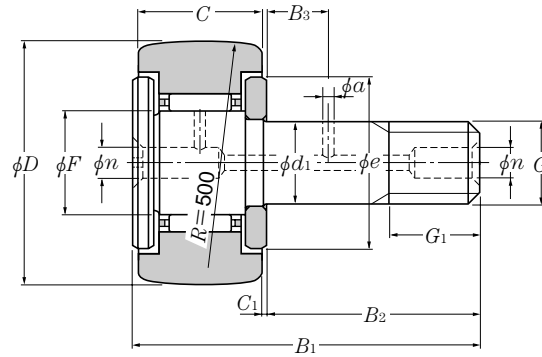

**Type KR
(With cage)**

D 10~52mm

Boundary dimensions

D	C	d ₁	F	B ₁	B ₂	mm							
						G	G ₁	C ₁	n	B ₃	a	e	h
10	7	3 ₀ ^{-0.010}	4.0	17	9	M 3×0.5	5	0.5	—	—	—	7	2.5 ³⁾
	7	3 ₀ ^{-0.010}	4.0	17	9	M 3×0.5	5	0.5	—	—	—	7	2.5 ³⁾
12	8	4 ₀ ^{-0.012}	4.8	20	11	M 4×0.7	6	0.5	—	—	—	8.5	2.5 ³⁾
	8	4 ₀ ^{-0.012}	4.8	20	11	M 4×0.7	6	0.5	—	—	—	8.5	2.5 ³⁾
13	9	5 ₀ ^{-0.012}	5.75	23	13	M 5×0.8	7.5	0.5	—	—	—	9.5	3 ³⁾
	9	5 ₀ ^{-0.012}	5.75	23	13	M 5×0.8	7.5	0.5	—	—	—	9.5	3 ³⁾
16	11	6 ₀ ^{-0.012}	8	28	16	M 6×1	8	0.6	4 ²⁾	—	—	12	3
	11	6 ₀ ^{-0.012}	8	28	16	M 6×1	8	0.6	4 ²⁾	—	—	12	3
19	11	8 ₀ ^{-0.015}	10	32	20	M 8×1.25	10	0.6	4 ²⁾	—	—	14	4
	11	8 ₀ ^{-0.015}	10	32	20	M 8×1.25	10	0.6	4 ²⁾	—	—	14	4
22	12	10 ₀ ^{-0.015}	12	36	23	M10×1.25	12	0.6	4	—	—	17	4
	12	10 ₀ ^{-0.015}	12	36	23	M10×1.25	12	0.6	4	—	—	17	4
26	12	10 ₀ ^{-0.015}	12	36	23	M10×1.25	12	0.6	4	—	—	17	4
	12	10 ₀ ^{-0.015}	12	36	23	M10×1.25	12	0.6	4	—	—	17	4
30	14	12 ₀ ^{-0.018}	15	40	25	M12×1.5	13	0.6	6	6	3	23	6
	14	12 ₀ ^{-0.018}	15	40	25	M12×1.5	13	0.6	6	6	3	23	6
32	14	12 ₀ ^{-0.018}	15	40	25	M12×1.5	13	0.6	6	6	3	23	6
	14	12 ₀ ^{-0.018}	15	40	25	M12×1.5	13	0.6	6	6	3	23	6
35	18	16 ₀ ^{-0.018}	18	52	32.5	M16×1.5	17	0.8	6	8	3	27	6
	18	16 ₀ ^{-0.018}	18	52	32.5	M16×1.5	17	0.8	6	8	3	27	6
40	20	18 ₀ ^{-0.018}	22	58	36.5	M18×1.5	19	0.8	6	8	3	32	6
	20	18 ₀ ^{-0.018}	22	58	36.5	M18×1.5	19	0.8	6	8	3	32	6
47	24	20 ₀ ^{-0.021}	25	66	40.5	M20×1.5	21	0.8	8	9	4	37	8
	24	20 ₀ ^{-0.021}	25	66	40.5	M20×1.5	21	0.8	8	9	4	37	8
52	24	20 ₀ ^{-0.021}	25	66	40.5	M20×1.5	21	0.8	8	9	4	37	8
	24	20 ₀ ^{-0.021}	25	66	40.5	M20×1.5	21	0.8	8	9	4	37	8

Note 1) For bearing with cylindrical outer surface, the nominal number is followed by "X" code. In this case, the cylindrical bearing is manufactured with the tolerance for outer ring outer diameter *D* which conforms to JIS Class-0. Ex. KR22XLL
 2) Grease replenishing hole is provided at front side only (on left side-face in the above sketch). However, in the case with "hexagon hole" no grease replenishing hole is provided.

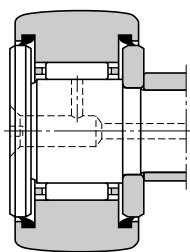

Type KR·LL
(Sealed type with cage)

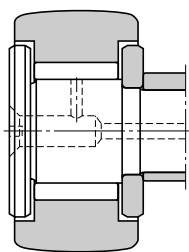

Type KRV
(Full complement type)

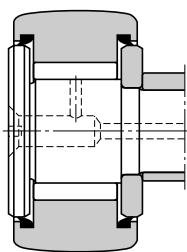

Type KRV·LL
(Full complement type with seal)

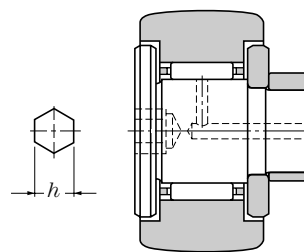

Type KR·H
(With hexagonal wrench socket)

Basic load ratings				Load ratings of truck				Limiting speeds		Maximum tightening torque		Bearing numbers		Mass (approx.)	
dynamic static		dynamic static		N		kgf		r /min		N·m kgf·m		Type NR ¹⁾	Type NR·LL ¹⁾	Type KR	Type KRV
C _r	C _{or}	C _r	C _{or}	Spherical outer ring	Cylindrical outer ring	Spherical outer ring	Cylindrical outer ring	grease	oil			Type KRV	Type KRV·LL		
1 640	1 270	168	130	560	1 360	57	139	※27 000	※40 000	0.5	0.05	KR10T2H/3A	KR10T2LLH	0.005	—
2 500	2 610	255	267	560	1 360	57	139	※25 000	※32 000	0.5	0.05	KRV10H	KRV10LLH	—	0.005
2 170	1 690	221	172	725	1 790	74	183	※25 000	※36 000	1	0.1	KR12T2H/3A	KR12T2LLH	0.008	—
3 500	3 800	360	385	725	1 790	74	183	※20 000	※27 000	1	0.1	KRV12H	KRV12LLH	—	0.008
2 650	2 260	270	231	805	2 220	82	226	※23 000	※33 000	2	0.2	KR13T2H/3A	KR13T2LLH	0.010	—
4 500	5 350	455	545	805	2 220	82	226	※17 000	※22 000	2	0.2	KRV13H	KRV13LLH	—	0.011
4 050	4 200	415	430	1 080	3 400	110	350	※19 000	※25 000	3	0.3	KR16	KR16LL	0.019	—
6 500	9 350	665	955	1 080	3 400	110	350	※13 000	※16 000	3	0.3	KRV16	KRV16LL	—	0.020
4 750	5 400	480	555	1 380	4 050	141	415	※15 000	※20 000	8	0.8	KR19	KR19LL	0.031	—
7 450	11 700	760	1 190	1 380	4 050	141	415	10 000	※13 000	8	0.8	KRV19	KRV19LL	—	0.032
5 300	6 650	540	680	1 690	5 150	172	525	※12 000	※16 000	14	1.4	KR22	KR22LL	0.046	—
8 200	14 000	840	1 420	1 690	5 150	172	525	8 500	※11 000	14	1.4	KRV22	KRV22LL	—	0.047
5 300	6 650	540	680	2 120	6 100	216	620	※12 000	※16 000	14	1.4	KR26	KR26LL	0.059	—
8 200	14 000	840	1 420	2 120	6 100	216	620	8 500	※11 000	14	1.4	KRV26	KRV26LL	—	0.061
7 850	9 650	800	985	2 620	7 700	267	785	10 000	※13 000	20	2	KR30	KR30LL	0.087	—
12 000	20 300	1 230	2 070	2 620	7 700	267	785	6 500	8 500	20	2	KRV30	KRV30LL	—	0.089
7 850	9 650	800	985	2 860	8 200	291	835	10 000	※13 000	20	2	KR32	KR32LL	0.097	—
12 000	20 300	1 230	2 070	2 860	8 200	291	835	6 500	8 500	20	2	KRV32	KRV32LL	—	0.100
12 200	17 900	1 240	1 830	3 200	11 900	325	1 220	8 000	※11 000	52	5.3	KR35	KR35LL	0.169	—
17 600	34 000	1 790	3 500	3 200	11 900	325	1 220	5 500	7 000	52	5.3	KRV35	KRV35LL	—	0.172
14 000	22 800	1 430	2 330	3 850	14 500	390	1 480	7 000	9 000	76	7.8	KR40	KR40LL	0.248	—
19 400	42 000	1 980	4 250	3 850	14 500	390	1 480	4 500	6 000	76	7.8	KRV40	KRV40LL	—	0.252
20 700	33 500	2 110	3 450	4 700	21 000	480	2 150	6 000	8 000	98	10	KR47	KR47LL	0.386	—
28 800	61 000	2 940	6 250	4 700	21 000	480	2 150	4 000	5 000	98	10	KRV47	KRV47LL	—	0.390
20 700	33 500	2 110	3 450	5 550	23 300	565	2 370	6 000	8 000	98	10	KR52	KR52LL	0.461	—
28 800	61 000	2 940	6 250	5 550	23 300	565	2 370	4 000	5 000	98	10	KRV52	KRV52LL	—	0.465

Note 3) Cam follower with hexagon hole is standard.

Remarks: For the cam follower with ※marked seal, the allowable running speed is approximately 10 000 r/min.

Metric series

Type KR

Type KR··LL

Type KRV

Type KRV··LL

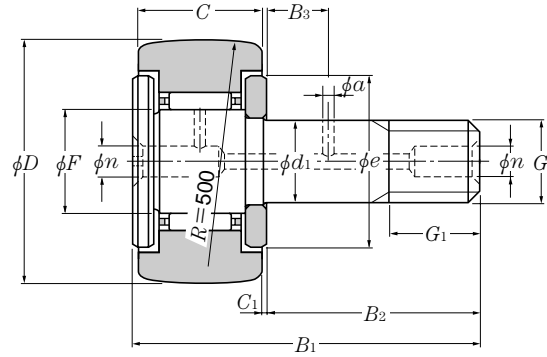

**Type KR
(With cage)**

D 62~90mm

Boundary dimensions

D ₀ ^{-0.050}	C	d ₁	F	B ₁	B ₂	mm							
						G	G ₁	C ₁	n	B ₃	a	e	h
62	29	24 ₀ ^{-0.021}	30	80	49.5	M24×1.5	25	0.8	8	11	4	44	8
	29	24 ₀ ^{-0.021}	30	80	49.5	M24×1.5	25	0.8	8	11	4	44	8
72	29	24 ₀ ^{-0.021}	30	80	49.5	M24×1.5	25	0.8	8	11	4	44	8
	29	24 ₀ ^{-0.021}	30	80	49.5	M24×1.5	25	0.8	8	11	4	44	8
80	35	30 ₀ ^{-0.021}	38	100	63	M30×1.5	32	1	8	15	4	53	8
	35	30 ₀ ^{-0.021}	38	100	63	M30×1.5	32	1	8	15	4	53	8
85	35	30 ₀ ^{-0.021}	38	100	63	M30×1.5	32	1	8	15	4	53	8
	35	30 ₀ ^{-0.021}	38	100	63	M30×1.5	32	1	8	15	4	53	8
90	35	30 ₀ ^{-0.021}	38	100	63	M30×1.5	32	1	8	15	4	53	8
	35	30 ₀ ^{-0.021}	38	100	63	M30×1.5	32	1	8	15	4	53	8

Note 1) For bearing with cylindrical outer surface, the nominal number is followed by "X" code. In this case, the cylindrical bearing is manufactured with the tolerance for outer ring outer diameter *D* which conforms to JIS Class-0. Ex. KR62XLL

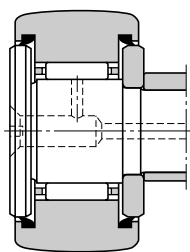

Type KR·LL
(Sealed type with cage)

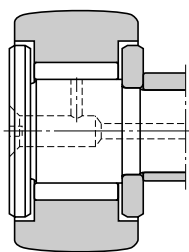

Type KRV
(Full complement type)

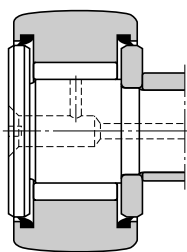

Type KRV·LL
(Full complement type with seal)

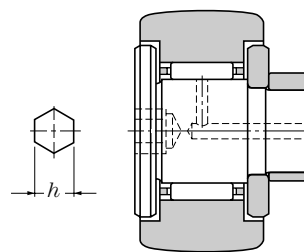

Type KR·H
(With hexagonal wrench socket)

Basic load ratings				Load ratings of truck				Limiting speeds		Maximum tightening torque		Bearing numbers		Mass (approx.)	
dynamic		static		N		kgf		r /min		N·m		Type NR ¹⁾		kg	
<i>C_r</i>	<i>C_{or}</i>	<i>C_r</i>	<i>C_{or}</i>	Spherical outer ring	Cylindrical outer ring	Spherical outer ring	Cylindrical outer ring	grease	oil	N·m	kgf·m	Type NR ¹⁾	Type NR·LL ¹⁾	Type KR	Type KRV
												Type KRV	Type KRV·LL		
28 900	55 000	2 950	5 600	6 950	34 500	710	3 500	5 000	6 500	178	18	KR62	KR62LL	0.790	—
39 500	98 500	4 000	10 000	6 950	34 500	710	3 500	3 300	4 500	178	18	KRV62	KRV62LL	—	0.800
28 900	55 000	2 950	5 600	8 050	38 500	820	3 900	5 000	6 500	178	18	KR72	KR72LL	1.04	—
39 500	98 500	4 000	10 000	8 050	38 500	820	3 900	3 300	4 500	178	18	KRV72	KRV72LL	—	1.05
45 000	88 500	4 600	9 050	9 800	53 000	1 000	5 400	40 00	5 500	360	37	KR80	KR80LL	1.55	—
58 000	147 000	5 900	15 000	9 800	53 000	1 000	5 400	2 600	3 500	360	37	KRV80	KRV80LL	—	1.56
45 000	88 500	4 600	9 050	10 400	56 000	1 060	5 750	4 000	5 500	360	37	KR85	KR85LL	1.74	—
45 000	88 500	4 600	9 050	11 400	59 000	1 160	6 100	4 000	5 500	360	37	KR90	KR90LL	1.95	—
58 000	147 000	5 900	15 000	11 400	59 000	1 160	6 100	2 600	3 500	360	37	KRV90	KRV90LL	—	1.97

Metric series

Type KRT

Type KRT··X

Type KRT··LL

Type KRT··XLL

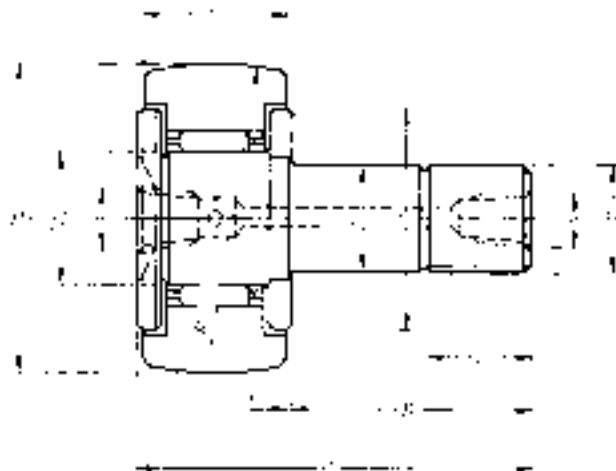
Type KRT
(With cage)

D 16~90mm

Boundary dimensions											Basic load ratings			
mm											dynamic	static	dynamic	static
$D^{1)}$	C	d_1	F	B_1	B_2	G	G_1	C_1	e	m	N	kgf		
											C_r	C_{or}	C_r	C_{or}
16	11	$6 \begin{smallmatrix} 0 \\ -0.012 \end{smallmatrix}$	8	28	16	M 6×1	8	0.6	12	M4×0.7 ²⁾	4 050	4 200	415	430
19	11	$8 \begin{smallmatrix} 0 \\ -0.015 \end{smallmatrix}$	10	32	20	M 8×1.25	10	0.6	14	M4×0.7 ²⁾	4 750	5 400	480	555
22	12	$10 \begin{smallmatrix} 0 \\ -0.015 \end{smallmatrix}$	12	36	23	M10×1.25	12	0.6	17	M4×0.7	5 300	6 650	540	680
26	12	$10 \begin{smallmatrix} 0 \\ -0.015 \end{smallmatrix}$	12	36	23	M10×1.25	12	0.6	17	M4×0.7	5 300	6 650	540	680
30	14	$12 \begin{smallmatrix} 0 \\ -0.018 \end{smallmatrix}$	15	40	25	M12×1.5	13	0.6	23	M6×0.75	7 850	9 650	800	985
32	14	$12 \begin{smallmatrix} 0 \\ -0.018 \end{smallmatrix}$	15	40	25	M12×1.5	13	0.6	23	M6×0.75	7 850	9 650	800	985
35	18	$16 \begin{smallmatrix} 0 \\ -0.018 \end{smallmatrix}$	18	52	32.5	M16×1.5	17	0.8	27	PT $\frac{1}{8}$	12 200	17 900	1 240	1 830
40	20	$18 \begin{smallmatrix} 0 \\ -0.018 \end{smallmatrix}$	22	58	36.5	M18×1.5	19	0.8	32	PT $\frac{1}{8}$	14 000	22 800	1 430	2 330
47	24	$20 \begin{smallmatrix} 0 \\ -0.021 \end{smallmatrix}$	25	66	40.5	M20×1.5	21	0.8	37	PT $\frac{1}{8}$	20 700	33 500	2 110	3 450
52	24	$20 \begin{smallmatrix} 0 \\ -0.021 \end{smallmatrix}$	25	66	40.5	M20×1.5	21	0.8	37	PT $\frac{1}{8}$	20 700	33 500	2 110	3 450
62	29	$24 \begin{smallmatrix} 0 \\ -0.021 \end{smallmatrix}$	30	80	49.5	M24×1.5	25	0.8	44	PT $\frac{1}{8}$	28 900	55 000	2 950	5 600
72	29	$24 \begin{smallmatrix} 0 \\ -0.021 \end{smallmatrix}$	30	80	49.5	M24×1.5	25	0.8	44	PT $\frac{1}{8}$	28 900	55 000	2 950	5 600
80	35	$30 \begin{smallmatrix} 0 \\ -0.021 \end{smallmatrix}$	38	100	63	M30×1.5	32	1	53	PT $\frac{1}{8}$	45 000	88 500	4 600	9 050
85	35	$30 \begin{smallmatrix} 0 \\ -0.021 \end{smallmatrix}$	38	100	63	M30×1.5	32	1	53	PT $\frac{1}{8}$	45 000	88 500	4 600	9 050
90	35	$30 \begin{smallmatrix} 0 \\ -0.021 \end{smallmatrix}$	38	100	63	M30×1.5	32	1	53	PT $\frac{1}{8}$	45 000	88 500	4 600	9 050

Note 1) The dimensional tolerances for the outer ring outer diameter D of Type KRT··X and KRT··XLL with cylindrical outer surface conform to JIS Class -0.
 2) A tapped hole is provided at front side only (on left end-face in the above sketch).

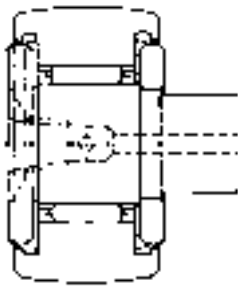

Type KR··LL
(with cage, sealed type)

Accessories

Nominal number of applied bearing	Nominal No. of grease nipple	Nominal No. of threaded plug with hexagon socket	Nominal No. of applied hexagon nut
30~35	JIS A-M6F	M6×0.75×6ℓ	1M12×1.5~1M16×1.5
40~180	JIS A-PT $\frac{1}{8}$	PT $\frac{1}{8}$ ×7ℓ	1M18×1.5~1M64×3

※Table 3 on B-179 and Table 5-2 on B-180 shows the respective boundary dimensions of grease nipple and threaded plug with hexagon socket.

Load ratings of truck				Limiting speeds		Maximum tightening torque		Bearing numbers				Mass kg (approx.)	Stud diameter mm
N		kgf		r/min grease	oil	N·m	kgf·m	Without seal		With seal			
Spherical outer ring	Cylindrical outer ring	Spherical outer ring	Cylindrical outer ring					Cylindrical outer ring	Spherical outer ring	Cylindrical outer ring	Spherical outer ring		
1 080	3 400	110	350	※19 000	※25 000	3	0.3	KRT16	KRT16X	KRT16LL	KRT16XLL	0.019	6
1 380	4 050	141	415	※15 000	※20 000	8	0.8	KRT19	KRT19X	KRT19LL	KRT19XLL	0.031	8
1 690	5 150	172	525	※12 000	※16 000	14	1.4	KRT22	KRT22X	KRT22LL	KRT22XLL	0.046	10
2 120	6 100	216	620	※12 000	※16 000	14	1.4	KRT26	KRT26X	KRT26LL	KRT26XLL	0.059	10
2 620	7 700	267	785	10 000	※13 000	20	2	KRT30	KRT30X	KRT30LL	KRT30XLL	0.087	12
2 860	8 200	291	835	10 000	※13 000	20	2	KRT32	KRT32X	KRT32LL	KRT32XLL	0.097	12
3 200	11 900	325	1 220	8 000	※11 000	52	5.3	KRT35	KRT35X	KRT35LL	KRT35XLL	0.169	16
3 850	14 500	390	1 480	7 000	9 000	76	7.8	KRT40	KRT40X	KRT40LL	KRT40XLL	0.248	18
4 700	21 000	480	2 150	6 000	8 000	98	10	KRT47	KRT47X	KRT47LL	KRT47XLL	0.386	20
5 550	23 300	565	2 370	6 000	8 000	98	10	KRT52	KRT52X	KRT52LL	KRT52XLL	0.461	20
6 950	34 500	710	3 500	5 000	6 500	178	18	KRT62	KRT62X	KRT62LL	KRT62XLL	0.790	24
8 050	38 500	820	3 900	5 000	6 500	178	18	KRT72	KRT72X	KRT72LL	KRT72XLL	1.04	24
9 800	53 000	1 000	5 400	4 000	5 500	360	37	KRT80	KRT80X	KRT80LL	KRT80XLL	1.55	30
10 400	56 000	1 060	5 750	4 000	5 500	360	37	KRT85	KRT85X	KRT85LL	KRT85XLL	1.74	30
11 400	59 000	1 160	6 100	4 000	5 500	360	37	KRT90	KRT90X	KRT90LL	KRT90XLL	1.95	30

Remarks: The allowable running speed of Type KRT··LL and KRT··XLL with ※marked seal is approximately 10 000r/min.

Metric series

Type KRT

Type RT··X

Type KRT··LL

Type KRT··XLL

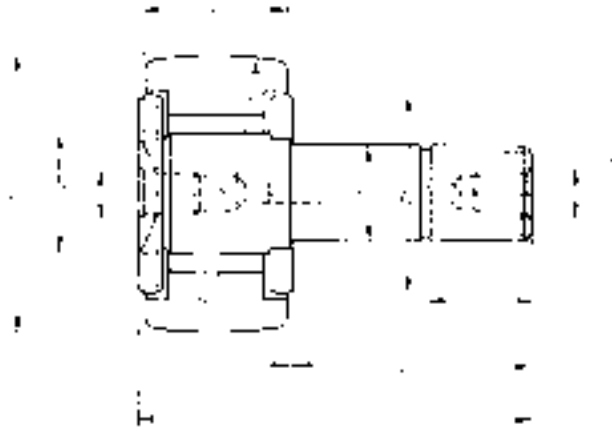
Type KRV
(Full-complement roller type)

D 16~90mm

Boundary dimensions											Basic load ratings			
mm											dynamic	static	dynamic	static
$D^{1)}$	C	d_1	F	B_1	B_2	G	G_1	C_1	e	m	N	kgf	kgf	kgf
											C_r	C_{or}	C_r	C_{or}
16	11	$6 \begin{smallmatrix} 0 \\ -0.012 \end{smallmatrix}$	8	28	16	M 6×1	8	0.6	12	M4×0.7 ²⁾	6 500	9 350	665	955
19	11	$8 \begin{smallmatrix} 0 \\ -0.015 \end{smallmatrix}$	10	32	20	M 8×1.25	10	0.6	14	M4×0.7 ²⁾	7 450	11 700	760	1 190
22	12	$10 \begin{smallmatrix} 0 \\ -0.015 \end{smallmatrix}$	12	36	23	M10×1.25	12	0.6	17	M4×0.7	8 200	14 000	840	1 420
26	12	$10 \begin{smallmatrix} 0 \\ -0.015 \end{smallmatrix}$	12	36	23	M10×1.25	12	0.6	17	M4×0.7	8 200	14 000	840	1 420
30	14	$12 \begin{smallmatrix} 0 \\ -0.018 \end{smallmatrix}$	15	40	25	M12×1.5	13	0.6	23	M6×0.75	12 000	20 300	1 230	2 070
32	14	$12 \begin{smallmatrix} 0 \\ -0.018 \end{smallmatrix}$	15	40	25	M12×1.5	13	0.6	23	M6×0.75	12 000	20 300	1 230	2 070
35	18	$16 \begin{smallmatrix} 0 \\ -0.018 \end{smallmatrix}$	18	52	32.5	M16×1.5	17	0.8	27	PT $\frac{1}{8}$	17 600	34 000	1 790	3 500
40	20	$18 \begin{smallmatrix} 0 \\ -0.018 \end{smallmatrix}$	22	58	36.5	M18×1.5	19	0.8	32	PT $\frac{1}{8}$	19 400	42 000	1 980	4 250
47	24	$20 \begin{smallmatrix} 0 \\ -0.021 \end{smallmatrix}$	25	66	40.5	M20×1.5	21	0.8	37	PT $\frac{1}{8}$	28 800	61 000	2 940	6 250
52	24	$20 \begin{smallmatrix} 0 \\ -0.021 \end{smallmatrix}$	25	66	40.5	M20×1.5	21	0.8	37	PT $\frac{1}{8}$	28 800	61 000	2 940	6 250
62	29	$24 \begin{smallmatrix} 0 \\ -0.021 \end{smallmatrix}$	30	80	49.5	M24×1.5	25	0.8	44	PT $\frac{1}{8}$	39 500	98 500	4 000	10 000
72	29	$24 \begin{smallmatrix} 0 \\ -0.021 \end{smallmatrix}$	30	80	49.5	M24×1.5	25	0.8	44	PT $\frac{1}{8}$	39 500	98 500	4 000	10 000
80	35	$30 \begin{smallmatrix} 0 \\ -0.021 \end{smallmatrix}$	38	100	63	M30×1.5	32	1	53	PT $\frac{1}{8}$	58 000	147 000	5 900	15 000
90	35	$30 \begin{smallmatrix} 0 \\ -0.021 \end{smallmatrix}$	38	100	63	M30×1.5	32	1	53	PT $\frac{1}{8}$	58 000	147 000	5 900	15 000

Note 1) The dimensional tolerances for the outer ring outer diameter D of Type KRVT··X and KRVT··XLL with cylindrical outer surface conform to JIS Class-0.
 2) A tapped hole is provided at front side only (on left end-face in the above sketch).

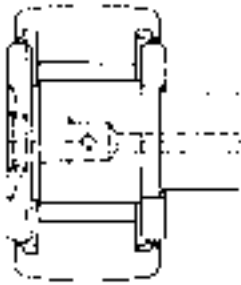

Accessories

Nominal number of applied bearing	Nominal No. of grease nipple	Nominal No. of threaded plug with hexagon socket	Nominal No. of applied hexagon nut
30~35	JIS A-M6F	M6×0.75×6ℓ	1M12×1.5~1M16×1.5
40~180	JIS A-PT $\frac{1}{8}$	PT $\frac{1}{8}$ ×7ℓ	1M18×1.5~1M64×3

※Table 3 on B-179 and Table 5-2 on B-180 shows the respective boundary dimensions of grease nipple and threaded plug with hexagon socket.

Type KRVT··LL
(Full-complement roller and sealed type)

Load ratings of truck				Limiting speeds		Maximum tightening torque		Bearing numbers				Mass kg (approx.)	Stud diameter mm
N		kgf		r/min grease	oil	N·m	kgf·m	Without seal		With seal			
Spherical outer ring	Cylindrical outer ring	Spherical outer ring	Cylindrical outer ring					Cylindrical outer ring	Spherical outer ring	Cylindrical outer ring	Spherical outer ring		
1 080	3 400	110	350	※13 000	※16 000	3	0.3	KRVT16	KRVT16X	KRVT16LL	KRVT16XLL	0.020	6
1 380	4 050	141	415	10 000	※13 000	8	0.8	KRVT19	KRVT19X	KRVT19LL	KRVT19XLL	0.032	8
1 690	5 150	172	525	8 500	※11 000	14	1.4	KRVT22	KRVT22X	KRVT22LL	KRVT22XLL	0.047	10
2 120	6 100	216	620	8 500	※11 000	14	1.4	KRVT26	KRVT26X	KRVT26LL	KRVT26XLL	0.061	10
2 620	7 700	267	785	6 500	8 500	20	2	KRVT30	KRVT30X	KRVT30LL	KRVT30XLL	0.089	12
2 860	8 200	291	835	6 500	8 500	20	2	KRVT32	KRVT32X	KRVT32LL	KRVT32XLL	0.100	12
3 200	11 900	325	1 220	5 500	7 000	52	5.3	KRVT35	KRVT35X	KRVT35LL	KRVT35XLL	0.172	16
3 850	14 500	390	1 480	4 500	6 000	76	7.8	KRVT40	KRVT40X	KRVT40LL	KRVT40XLL	0.252	18
4 700	21 000	480	2 150	4 000	5 000	98	10	KRVT47	KRVT47X	KRVT47LL	KRVT47XLL	0.390	20
5 550	23 300	565	2 370	4 000	5 000	98	10	KRVT52	KRVT52X	KRVT52LL	KRVT52XLL	0.465	20
6 950	34 500	710	3 500	3 300	4 500	178	18	KRVT62	KRVT62X	KRVT62LL	KRVT62XLL	0.800	24
8 050	38 500	820	3 900	3 300	4 500	178	18	KRVT72	KRVT72X	KRVT72LL	KRVT72XLL	1.05	24
9 800	53 000	1 000	5 400	2 600	3 500	360	37	KRVT80	KRVT80X	KRVT80LL	KRVT80XLL	1.56	30
11 400	59 000	1 160	6 100	2 600	3 500	360	37	KRVT90	KRVT90X	KRVT90LL	KRVT90XLL	1.97	30

Remarks: The allowable running speed of Type KRVT··LL and KRVT··XLL with ※marked seal is approximately 10 000r/min.

Metric Series

- Type KRU
- Type KRU··LL
- Type KRVU
- Type KRVU··LL

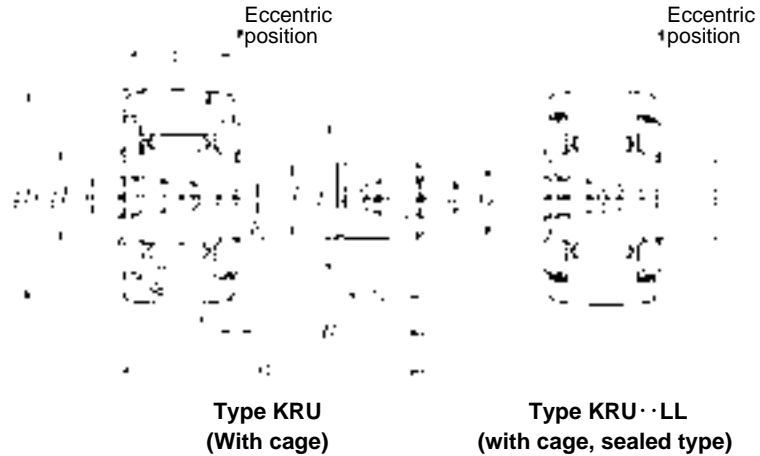

D 16~80mm

D	C	Boundary dimensions										Basic load ratings			
		d ₁	F	B ₁	B ₂	mm		G ₁	C ₁	e	m	E	dynamic	static	dynamic
⁰ / _{-0.050}						G					eccentricity	N	N	kgf	kgf
16	11	6 ⁰	8	28	16	M 6×1	8	0.6	12	M4×0.7 ²⁾	0.25	4 050	4 200	415	430
	11	6 ^{-0.012}	8	28	16	M 6×1	8	0.6	12	M4×0.7 ²⁾	0.25	6 500	9 350	665	955
19	11	8 ⁰	10	32	20	M 8×1.25	10	0.6	14	M4×0.7 ²⁾	0.25	4 750	5 400	480	555
	11	8 ^{-0.015}	10	32	20	M 8×1.25	10	0.6	14	M4×0.7 ²⁾	0.25	7 450	11 700	760	1 190
22	12	10 ⁰	12	36	23	M10×1.25	12	0.6	17	M4×0.7	0.3	5 300	6 650	540	680
	12	10 ^{-0.015}	12	36	23	M10×1.25	12	0.6	17	M4×0.7	0.3	8 200	14 000	840	1 420
26	12	10 ⁰	12	36	23	M10×1.25	12	0.6	17	M4×0.7	0.3	5 300	6 650	540	680
	12	10 ^{-0.015}	12	36	23	M10×1.25	12	0.6	17	M4×0.7	0.3	8 200	14 000	840	1 420
30	14	12 ⁰	15	40	25	M12×1.5	13	0.6	23	M6×0.75	0.4	7 850	9 650	800	985
	14	12 ^{-0.018}	15	40	25	M12×1.5	13	0.6	23	M6×0.75	0.4	12 000	20 300	1 230	2 070
32	14	12 ⁰	15	40	25	M12×1.5	13	0.6	23	M6×0.75	0.4	7 850	9 650	800	985
	14	12 ^{-0.018}	15	40	25	M12×1.5	13	0.6	23	M6×0.75	0.4	12 000	20 300	1 230	2 070
35	18	16 ⁰	18	52	32.5	M16×1.5	17	0.8	27	M6×0.75	0.5	12 500	18 900	1 280	1 930
	18	16 ^{-0.018}	18	52	32.5	M16×1.5	17	0.8	27	M6×0.75	0.5	18 000	36 500	1 840	3 700
40	20	18 ⁰	22	58	36.5	M18×1.5	19	0.8	32	PT ¹ / ₈	0.6	14 000	22 800	1 430	2 330
	20	18 ^{-0.018}	22	58	36.5	M18×1.5	19	0.8	32	PT ¹ / ₈	0.6	19 400	42 000	1 980	4 250
47	24	20 ⁰	25	66	40.5	M20×1.5	21	0.8	37	PT ¹ / ₈	0.7	20 700	33 500	2 110	3 450
	24	20 ^{-0.021}	25	66	40.5	M20×1.5	21	0.8	37	PT ¹ / ₈	0.7	28 800	61 000	2 940	6 250
52	24	20 ⁰	25	66	40.5	M20×1.5	21	0.8	37	PT ¹ / ₈	0.7	20 700	33 500	2 110	3 450
	24	20 ^{-0.021}	25	66	40.5	M20×1.5	21	0.8	37	PT ¹ / ₈	0.7	28 800	61 000	2 940	6 250
62	29	24 ⁰	30	80	49.5	M24×1.5	25	0.8	44	PT ¹ / ₈	0.8	28 900	55 000	2 950	5 600
	29	24 ^{-0.021}	30	80	49.5	M24×1.5	25	0.8	44	PT ¹ / ₈	0.8	39 500	98 500	4 000	10 000
72	29	24 ⁰	30	80	49.5	M24×1.5	25	0.8	44	PT ¹ / ₈	0.8	28 900	55 000	2 950	5 600
	29	24 ^{-0.021}	30	80	49.5	M24×1.5	25	0.8	44	PT ¹ / ₈	0.8	39 500	98 500	4 000	10 000
80	35	30 ⁰	38	100	63	M30×1.5	32	1	53	PT ¹ / ₈	1.0	45 000	88 500	4 600	9 050
	35	30 ^{-0.021}	38	100	63	M30×1.5	32	1	53	PT ¹ / ₈	1.0	58 000	147 000	5 900	15 000

Note 1) For bearing with cylindrical outer surface, the nominal number is followed by "X" code. In this case, the cylindrical bearing is manufactured with the tolerance for outer ring outer diameter D which conforms to JIS Class-0. Ex. KRU52XLL
 2) A tapped hole is provided at front side only (on left side-face in the above sketch).

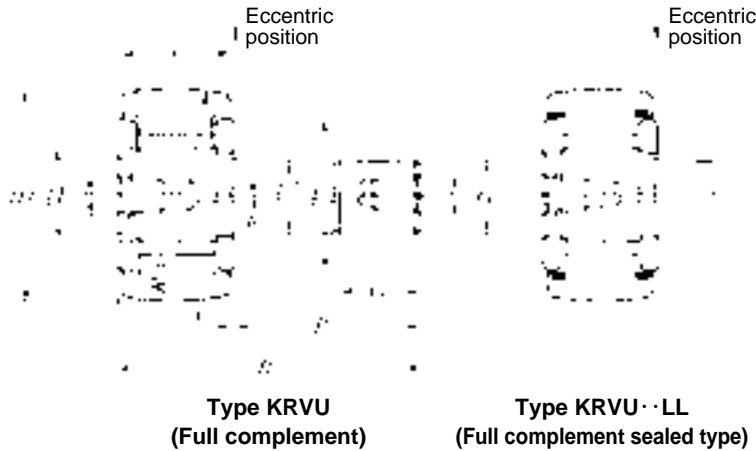

Accessories

Nominal number of applied bearing	Nominal No. of grease nipple	Nominal No. of threaded plug with hexagon socket	Nominal No. of applied hexagon nut
16~26	NIP-X30	M4×0.7 ×4ℓ	1M 6×1 ~1M10×1.25
30~35	JIS A-M6F	M6×0.75×6ℓ	1M12×1.5~1M16×1.5
40~90	JIS A-PT $\frac{1}{8}$	PT $\frac{1}{8}$ ×7ℓ	1M18×1.5~1M30×1.5

※ Table 3 on B-179 and Table 5-2 on B-180 shows the respective boundary dimensions of grease nipple and threaded plug with hexagon socket.

Load ratings of truck				Limiting speeds		Maximum tightening torque		Bearing numbers		Mass (approx.) kg	
N		kgf		r/min							
Cylindrical outer ring	Spherical outer ring	Cylindrical outer ring	Spherical outer ring	grease	oil	N·m	kgf·m	Type KRU ¹⁾ Type KRUV	Type KRU·LL ¹⁾ Type KRUV·LL	Type KRU	Type KRUV
1 080	3 400	110	350	※19 000	※25 000	3	0.3	KRU16	KRU16LL	0.019	—
1 080	3 400	110	350	※13 000	※16 000	3	0.3	KRVU16	KRVU16LL	—	0.020
1 380	4 050	141	415	※15 000	※20 000	8	0.8	KRU19	KRU19LL	0.031	—
1 380	4 050	141	415	10 000	※13 000	8	0.8	KRVU19	KRVU19LL	—	0.032
1 690	5 150	172	525	※12 000	※16 000	14	1.4	KRU22	KRU22LL	0.046	—
1 690	5 150	172	525	8 500	※11 000	14	1.4	KRVU22	KRVU22LL	—	0.047
2 120	6 100	216	620	※12 000	※16 000	14	1.4	KRU26	KRU26LL	0.059	—
2 120	6 100	216	620	8 500	※11 000	14	1.4	KRVU26	KRVU26LL	—	0.061
2 620	7 700	267	785	10 000	※13 000	20	2	KRU30	KRU30LL	0.087	—
2 620	7 700	267	785	6 500	8 500	20	2	KRVU30	KRVU30LL	—	0.089
2 860	8 200	291	835	10 000	※13 000	20	2	KRU32	KRU32LL	0.097	—
2 860	8 200	291	835	6 500	8 500	20	2	KRVU32	KRVU32LL	—	0.100
3 200	11 900	325	1 220	8 000	※11 000	52	5.3	KRU35	KRU35LL	0.169	—
3 200	11 900	325	1 220	5 500	7 000	52	5.3	KRVU35	KRVU35LL	—	0.172
3 850	14 500	390	1 480	7 000	9 000	76	7.8	KRU40	KRU40LL	0.248	—
3 850	14 500	390	1 480	4 500	6 000	76	7.8	KRVU40	KRVU40LL	—	0.252
4 700	21 000	480	2 150	6 000	8 000	98	10	KRU47	KRU47LL	0.386	—
4 700	21 000	480	2 150	4 000	5 000	98	10	KRVU47	KRVU47LL	—	0.390
5 550	23 300	565	2 370	6 000	8 000	98	10	KRU52	KRU52LL	0.461	—
5 550	23 300	565	2 370	4 000	5 000	98	10	KRVU52	KRVU52LL	—	0.465
6 950	34 500	710	3 500	5 000	6 500	178	18	KRU62	KRU62LL	0.790	—
6 950	34 500	710	3 500	3 300	4 500	178	18	KRVU62	KRVU62LL	—	0.800
8 050	38 500	820	3 900	5 000	6 500	178	18	KRU72	KRU72LL	1.04	—
8 050	38 500	820	3 900	3 300	4 500	178	18	KRVU72	KRVU72LL	—	1.05
9 800	53 000	1 000	5 400	4 000	5 500	360	37	KRU80	KRU80LL	1.55	—
9 800	53 000	1 000	5 400	2 600	3 500	360	37	KRVU80	KRVU80LL	—	1.56

Remarks: For the cam follower with ※marked seal, the allowable running speed is approximately 10 000 r/min.

Metric Series

- Type KRU
- Type KRU··LL
- Type KRVU
- Type KRVU··LL

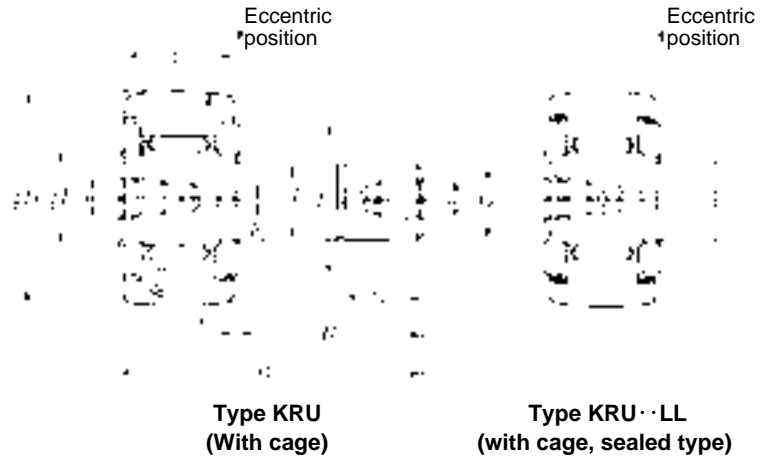

D 85~90mm

Boundary dimensions													Basic load ratings			
D -0.050	C	d ₁	F	B ₁	B ₂	mm						E eccentricity	dynamic	static	dynamic	static
						G	G ₁	C ₁	e	m	N		N	kgf	kgf	
85	35	30	⁰ / _{-0.021}	38	100	63	M30×1.5	32	1	53	PT ¹ / ₈	1.0	45 000	88 500	4 600	9 050
	35	30	⁰ / _{-0.021}	38	100	63	M30×1.5	32	1	53	PT ¹ / ₈	1.0	45 000	88 500	4 600	9 050
90	35	30	⁰ / _{-0.021}	38	100	63	M30×1.5	32	1	53	PT ¹ / ₈	1.0	58 000	147 000	5 900	15 000
	35	30	⁰ / _{-0.021}	38	100	63	M30×1.5	32	1	53	PT ¹ / ₈	1.0	58 000	147 000	5 900	15 000

Note 1) For bearing with cylindrical outer surface, the nominal number is followed by "X" code. In this case, the cylindrical bearing is manufactured with the tolerance for outer ring outer diameter D which conforms to JIS Class-0. Ex. KRU85XLL

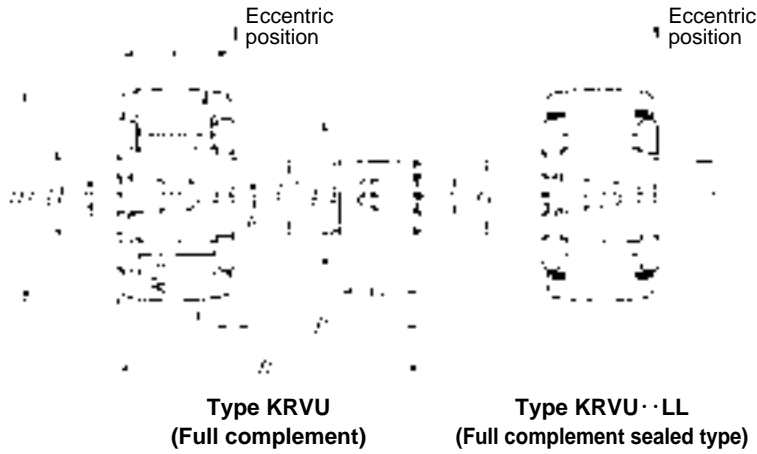

Accessories

Nominal number of applied bearing	Nominal No. of grease nipple	Nominal No. of threaded plug with hexagon socket	Nominal No. of applied hexagon nut
16~26	NIP-X30	M4×0.7 ×4ℓ	1M 6×1 ~1M10×1.25
30~35	JIS A-M6F	M6×0.75×6ℓ	1M12×1.5~1M16×1.5
40~90	JIS A-PT $\frac{1}{8}$	PT $\frac{1}{8}$ ×7ℓ	1M18×1.5~1M30×1.5

※Table 3 on B-179 and Table 5-2 on B-180 shows the respective boundary dimensions of grease nipple and threaded plug with hexagon socket.

Load ratings of truck				Limiting speeds		Maximum tightening torque		Bearing numbers		Mass (approx.) kg	
N		kgf		r/min				Type KRU ¹⁾	Type KRU·LL ¹⁾	Type KRU	Type KRVU
Cylindrical outer ring	Spherical outer ring	Cylindrical outer ring	Spherical outer ring	grease	oil	N·m	kgf·m	Type KRVU	Type KRVU·LL		
10 400	56 000	1 060	5 750	4 000	5 500	360	37	KRU85	KRU85LL	1.74	—
11 400	59 000	1 160	6 100	4 000	5 500	360	37	KRU90	KRU90LL	1.95	—
11 400	59 000	1 160	6 100	2 600	3 500	360	37	KRVU90	KRVU90LL	—	1.97

Metric Series

Type NUKR

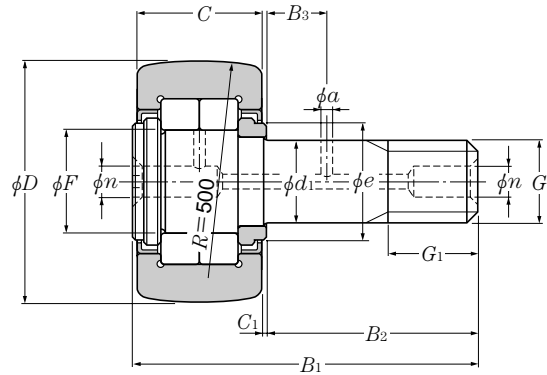

Type NUKR ($D < 100\text{mm}$) (Double row type full complement with seal)

D 30~180mm

Boundary dimensions														
mm														
D 0 -0.050	C	d_1	F	B_1	B_2	G	G_1	C_1	n	m	B_3	a	e	h
30	14	12 ⁰ _{-0.018}	14.5	40	25	M12×1.5	13	0.6	6	—	6	3	15	6
35	18	16 ⁰ _{-0.018}	19	52	32.5	M16×1.5	17	0.8	6	—	8	3	21	6
40	20	18 ⁰ _{-0.018}	21.5	58	36.5	M18×1.5	19	0.8	6	—	8	3	23	6
47	24	20 ⁰ _{-0.021}	25.5	66	40.5	M20×1.5	21	0.8	8	—	9	4	27	8
52	24	20 ⁰ _{-0.021}	30	66	40.5	M20×1.5	21	0.8	8	—	9	4	31	8
62	29	24 ⁰ _{-0.021}	35	80	49.5	M24×1.5	25	0.8	8	—	11	4	38	8
72	29	24 ⁰ _{-0.021}	41.5	80	49.5	M24×1.5	25	0.8	8	—	11	4	44	8
80	35	30 ⁰ _{-0.021}	47.5	100	63	M30×1.5	32	1	8	—	15	4	51	8
90	35	30 ⁰ _{-0.021}	47.5	100	63	M30×1.5	32	1	8	—	15	4	51	8
100	43	36 ⁰ _{-0.025}	48.5	120	74	M36×1.5	38	1.5	8	PT1/8	—	—	53	14
120	50	42 ⁰ _{-0.025}	60.5	140	87	M42×1.5	44	1.5	8	PT1/8	—	—	66	14
140	57	48 ⁰ _{-0.025}	65	160	100	M48×1.5	52	1.5	8	PT1/8	—	—	72.5	14
150	60	52 ⁰ _{-0.030}	75.5	170	107	M52×1.5	52	1.5	8	PT1/8	—	—	85.5	17
160	63	56 ⁰ _{-0.030}	80.5	180	113	M56×3	58	2	8	PT1/8	—	—	89.5	17
170	66	60 ⁰ _{-0.030}	86	190	120	M60×3	58	2	8	PT1/8	—	—	96.5	17
180	72	64 ⁰ _{-0.030}	91.5	200	124	M64×3	65	2	8	PT1/8	—	—	103.5	17

Note 1) For bearing with cylindrical outer surface, the nominal number is followed by "X" code. In this case, the cylindrical bearing is manufactured with the tolerance for outer ring outer diameter D which conforms to JIS Class-0. Ex. NUKR52X

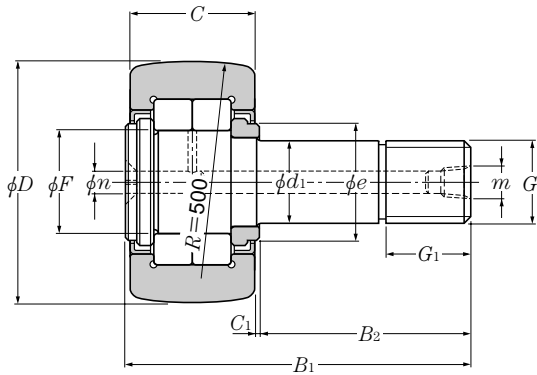

Type NUKR ($D \geq 100\text{mm}$)

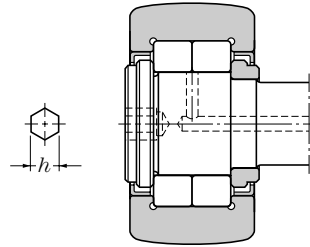

Type NUKR · H
(With hexagonal wrench socket)

Basic load ratings				Load ratings of truck				Limiting speeds r/min grease	Maximum tightening torque		Bearing numbers Type KUKR ¹⁾	Mass (approx.) kg Type KUKR
dynamic		static		N		kgf			N · m	kgf · m		
C_r	C_{or}	C_r	C_{or}	Spherical outer ring	Cylindrical outer ring	Spherical outer ring	Cylindrical outer ring					
13 300	13 500	1 360	1 380	2 620	7 700	267	785	6 900	20	2	NUKR 30	0.088
22 300	25 700	2 280	2 620	3 200	11 900	325	1 220	5 500	52	5.3	NUKR 35	0.165
24 100	29 100	2 450	2 970	3 850	14 500	390	1 480	4 700	76	7.8	NUKR 40	0.242
38 500	48 000	3 950	4 900	4 700	21 000	480	2 150	4 000	98	10	NUKR 47	0.380
42 500	57 500	4 350	5 850	5 550	23 300	565	2 370	3 300	98	10	NUKR 52	0.450
56 500	72 500	5 750	7 400	6 950	34 500	710	3 500	2 900	178	18	NUKR 62	0.795
62 000	85 500	6 350	8 700	8 050	38 500	820	3 900	2 400	178	18	NUKR 72	1.01
101 000	151 000	10 300	15 400	9 800	53 000	1 000	5 400	2 100	360	37	NUKR 80	1.54
101 000	151 000	10 300	15 400	11 400	59 000	1 160	6 100	2 100	360	37	NUKR 90	1.96
119 000	167 000	12 100	17 000	13 000	79 000	1 300	8 050	2 000	630	65	NUKR100	3.08
172 000	266 000	17 600	27 100	16 400	113 000	1 670	11 500	1 700	1 020	105	NUKR120	5.17
201 000	294 000	20 500	30 000	20 000	152 000	2 040	15 500	1 500	1 540	160	NUKR140	7.98
258 000	380 000	26 300	39 000	22 000	173 000	2 250	17 600	1 300	1 950	200	NUKR150	9.70
274 000	400 000	27 900	41 000	24 000	194 000	2 450	19 800	1 200	2 480	250	NUKR160	11.7
320 000	475 000	32 500	48 500	26 000	218 000	2 650	22 200	1 100	3 030	310	NUKR170	13.9
365 000	555 000	37 500	56 500	27 900	253 000	2 840	25 800	1 000	3 670	375	NUKR180	17.0

Metric Series

Type NUKRT

Type NUKRT··X

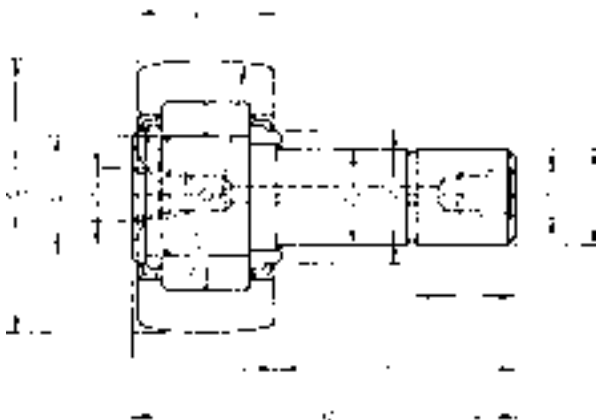

Type NUKRT
(Shielded full-complement roller, double-row cylindrical roller type)

D 30~180mm

D ¹⁾	C	Boundary dimensions										Basic load ratings			
		d ₁	F	B ₁	mm		G	G ₁	C ₁	e	m	dynamic	static	dynamic	static
					B ₂	G						N	C _{or}	C _r	C _{or}
30	14	12 ⁰ _{-0.018}	14.5	40	25	M12×1.5	13	0.6	15	M6×0.75	13 300	13 500	1 360	1 380	
35	18	16 ⁰ _{-0.018}	19	52	32.5	M16×1.5	17	0.8	21	PT ¹ / ₈	22 300	25 700	2 280	2 620	
40	20	18 ⁰ _{-0.018}	21.5	58	36.5	M18×1.5	19	0.8	23	PT ¹ / ₈	24 100	29 100	2 450	2 970	
47	24	20 ⁰ _{-0.021}	25.5	66	40.5	M20×1.5	21	0.8	27	PT ¹ / ₈	38 500	48 000	3 950	4 900	
52	24	20 ⁰ _{-0.021}	30	66	40.5	M20×1.5	21	0.8	31	PT ¹ / ₈	42 500	57 500	4 350	5 850	
62	29	24 ⁰ _{-0.021}	35	80	49.5	M24×1.5	25	0.8	38	PT ¹ / ₈	56 500	72 500	5 750	7 400	
72	29	24 ⁰ _{-0.021}	41.5	80	49.5	M24×1.5	25	0.8	44	PT ¹ / ₈	62 000	85 500	6 350	8 700	
80	35	30 ⁰ _{-0.021}	47.5	100	63	M30×1.5	32	1	51	PT ¹ / ₈	101 000	151 000	10 300	15 400	
90	35	30 ⁰ _{-0.021}	47.5	100	63	M30×1.5	32	1	51	PT ¹ / ₈	101 000	151 000	10 300	15 400	
100	43	36 ⁰ _{-0.025}	48.5	120	74	M36×1.5	38	1.5	53	PT ¹ / ₈	119 000	167 000	12 100	17 000	
120	50	42 ⁰ _{-0.025}	60.5	140	87	M42×1.5	44	1.5	66	PT ¹ / ₈	172 000	266 000	17 600	27 100	
140	57	48 ⁰ _{-0.025}	65	160	100	M48×1.5	52	1.5	72.5	PT ¹ / ₈	201 000	294 000	20 500	30 000	
150	60	52 ⁰ _{-0.030}	75.5	170	107	M52×1.5	52	1.5	85.5	PT ¹ / ₈	258 000	380 000	26 300	39 000	
160	63	56 ⁰ _{-0.030}	80.5	180	113	M56×3	58	2	89.5	PT ¹ / ₈	274 000	400 000	27 900	41 000	
170	66	60 ⁰ _{-0.030}	86	190	120	M60×3	58	2	96.5	PT ¹ / ₈	320 000	475 000	32 500	48 500	
180	72	64 ⁰ _{-0.030}	91.5	200	124	M64×3	65	2	103.5	PT ¹ / ₈	365 000	555 000	37 500	56 500	

 Note 1) The dimensional tolerance for the outer ring outer diameter *D* of Type NUKRT··X with cylindrical outer surface conforms to JIS Class-0.

Accessories

Nominal number of applied bearing	Nominal No. of grease nipple	Nominal No. of threaded plug with hexagon socket	Nominal No. of applied hexagon nut
30	JIS A-M6F	M6×0.75×6ℓ	1M12×1.5
35~180	JIS A-PT $\frac{1}{8}$	PT $\frac{1}{8}$ ×7ℓ	1M16×1.5~1M64×3

※Table 3 on B-179 and Table 5-2 on B-180 shows the respective boundary dimensions of grease nipple and threaded plug with hexagon socket.

Load ratings of truck				Limiting speeds r/min grease	Maximum tightening torque		Bearing numbers		Mass kg (approx.)	Stud diameter mm
N		kgf			N·m	kgf·m	Cylindrical outer ring	Spherical outer ring		
Spherical outer ring	Cylindrical outer ring	Spherical outer ring	Cylindrical outer ring							
2 620	7 700	267	785	6 900	20	2	NUKRT30	NUKRT30X	0.088	12
3 200	11 900	325	1 220	5 500	52	5.3	NUKRT35	NUKRT35X	0.165	16
3 850	14 500	390	1 480	4 700	76	7.8	NUKRT40	NUKRT40X	0.242	18
4 700	21 000	480	2 150	4 000	98	10	NUKRT47	NUKRT47X	0.380	20
5 550	23 300	565	2 370	3 300	98	10	NUKRT52	NUKRT52X	0.450	20
6 950	34 500	710	3 500	2 900	178	18	NUKRT62	NUKRT62X	0.795	24
8 050	38 500	820	3 900	2 400	178	18	NUKRT72	NUKRT72X	1.01	24
9 800	53 000	1 000	5 400	2 100	360	37	NUKRT80	NUKRT80X	1.54	30
11 400	59 000	1 160	6 100	2 100	360	37	NUKRT90	NUKRT90X	1.96	30
13 000	79 000	1 300	8 050	2 000	630	65	NUKRT100	NUKRT100X	3.08	36
16 400	113 000	1 670	11 500	1 700	1 020	105	NUKRT120	NUKRT120X	5.17	42
20 000	152 000	2 040	15 500	1 500	1 540	160	NUKRT140	NUKRT140X	7.98	48
22 000	173 000	2 250	17 600	1 300	1 950	200	NUKRT150	NUKRT150X	9.70	52
24 000	194 000	2 450	19 800	1 200	2 480	250	NUKRT160	NUKRT160X	11.7	56
26 000	218 000	2 650	22 200	1 100	3 030	310	NUKRT170	NUKRT170X	13.9	60
27 900	253 000	2 840	25 800	1 000	3 670	375	NUKRT180	NUKRT180X	17.0	64

Metric Series

Type NUKRU

Type NUKRU··X

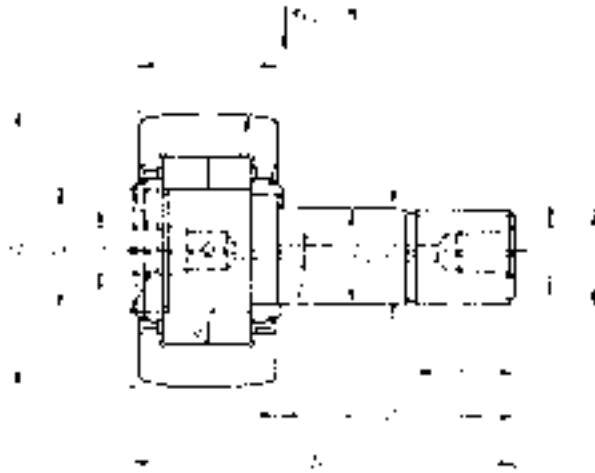

Type NUKRU

(Shielded full-complement roller, double-row cylindrical roller type)

D 30~180mm

D ¹⁾	C	d ₁	F	B ₁	B ₂	Boundary dimensions						Basic load ratings		
						mm						N		
						G	G ₁	C ₁	e	m	E eccentricity	C _r	C _{or}	
30	14	12	$\begin{smallmatrix} 0 \\ -0.018 \end{smallmatrix}$	14.5	40	25	M12×1.5	13	0.6	15	M6×0.75	0.4	13 300	13 500
35	18	16	$\begin{smallmatrix} 0 \\ -0.018 \end{smallmatrix}$	19	52	32.5	M16×1.5	17	0.8	21	M6×0.75	0.5	22 300	25 700
40	20	18	$\begin{smallmatrix} 0 \\ -0.018 \end{smallmatrix}$	21.5	58	36.5	M18×1.5	19	0.8	23	PT $\frac{1}{8}$	0.6	24 100	29 100
47	24	20	$\begin{smallmatrix} 0 \\ -0.021 \end{smallmatrix}$	25.5	66	40.5	M20×1.5	21	0.8	27	PT $\frac{1}{8}$	0.7	38 500	48 000
52	24	20	$\begin{smallmatrix} 0 \\ -0.021 \end{smallmatrix}$	30	66	40.5	M20×1.5	21	0.8	31	PT $\frac{1}{8}$	0.7	42 500	57 500
62	29	24	$\begin{smallmatrix} 0 \\ -0.021 \end{smallmatrix}$	35	80	49.5	M24×1.5	25	0.8	38	PT $\frac{1}{8}$	0.8	56 500	72 500
72	29	24	$\begin{smallmatrix} 0 \\ -0.021 \end{smallmatrix}$	41.5	80	49.5	M24×1.5	25	0.8	44	PT $\frac{1}{8}$	1.0	62 000	85 500
80	35	30	$\begin{smallmatrix} 0 \\ -0.021 \end{smallmatrix}$	47.5	100	63	M30×1.5	32	1	51	PT $\frac{1}{8}$	1.0	101 000	151 000
90	35	30	$\begin{smallmatrix} 0 \\ -0.021 \end{smallmatrix}$	47.5	100	63	M30×1.5	32	1	51	PT $\frac{1}{8}$	1.0	101 000	151 000
100	43	36	$\begin{smallmatrix} 0 \\ -0.025 \end{smallmatrix}$	48.5	120	74	M36×1.5	38	1.5	53	PT $\frac{1}{8}$	1.5	119 000	167 000
120	50	42	$\begin{smallmatrix} 0 \\ -0.025 \end{smallmatrix}$	60.5	140	87	M42×1.5	44	1.5	66	PT $\frac{1}{8}$	1.5	172 000	266 000
140	57	48	$\begin{smallmatrix} 0 \\ -0.025 \end{smallmatrix}$	65	160	100	M48×1.5	52	1.5	72.5	PT $\frac{1}{8}$	2	201 000	294 000
150	60	52	$\begin{smallmatrix} 0 \\ -0.030 \end{smallmatrix}$	75.5	170	107	M52×1.5	52	1.5	85.5	PT $\frac{1}{8}$	2	258 000	380 000
160	63	56	$\begin{smallmatrix} 0 \\ -0.030 \end{smallmatrix}$	80.5	180	113	M56×3	58	2	89.5	PT $\frac{1}{8}$	2	274 000	400 000
170	66	60	$\begin{smallmatrix} 0 \\ -0.030 \end{smallmatrix}$	86	190	120	M60×3	58	2	96.5	PT $\frac{1}{8}$	2.5	320 000	475 000
180	72	64	$\begin{smallmatrix} 0 \\ -0.030 \end{smallmatrix}$	91.5	200	124	M64×3	65	2	103.5	PT $\frac{1}{8}$	2.5	365 000	555 000

Note 1) The dimensional tolerance for the outer ring outer diameter D of Type NUKRU··X with cylindrical outer surface conforms to JIS Class-0.

Accessories

Nominal number of applied bearing	Nominal No. of grease nipple	Nominal No. of threaded plug with hexagon socket	Nominal No. of applied hexagon nut
30~35	JIS A-M6F	M6×0.75×6ℓ	1M12×1.5~1M16×1.5
40~180	JIS A-PT $\frac{1}{8}$	PT $\frac{1}{8}$ ×7ℓ	1M18×1.5~1M64×3

※Table 3 on B-179 and Table 5-2 on B-180 shows the respective boundary dimensions of grease nipple and threaded plug with hexagon socket.

Basic load ratings		Load ratings of truck				Limiting speeds r/min grease	Maximum tightening torque		Bearing numbers		Mass kg (approx.)	Stud diameter mm
dynamic kgf C_r	static kgf C_{or}	N		kgf			N·m	kgf·m	Cylindrical outer ring	Spherical outer ring		
1 360	1 380	2 620	7 700	267	785	6 900	20	2	NUKRU30	NUKRU30X	0.088	12
2 280	2 620	3 200	11 900	325	1 220	5 500	52	5.3	NUKRU35	NUKRU35X	0.165	16
2 450	2 970	3 850	14 500	390	1 480	4 700	76	7.8	NUKRU40	NUKRU40X	0.242	18
3 950	4 900	4 700	21 000	480	2 150	4 000	98	10	NUKRU47	NUKRU47X	0.380	20
4 350	5 850	5 550	23 300	565	2 370	3 300	98	10	NUKRU52	NUKRU52X	0.450	20
5 750	7 400	6 950	34 500	710	3 500	2 900	178	18	NUKRU62	NUKRU62X	0.795	24
6 350	8 700	8 050	38 500	820	3 900	2 400	178	18	NUKRU72	NUKRU72X	1.01	24
10 300	15 400	9 800	53 000	1 000	5 400	2 100	360	37	NUKRU80	NUKRU80X	1.54	30
10 300	15 400	11 400	59 000	1 160	6 100	2 100	360	37	NUKRU90	NUKRU90X	1.96	30
12 100	17 000	13 000	79 000	1 300	8 050	2 000	630	65	NUKRU100	NUKRU100X	3.08	36
17 600	27 100	16 400	113 000	1 670	11 500	1 700	1 020	105	NUKRU120	NUKRU120X	5.17	42
20 500	30 000	20 000	152 000	2 040	15 500	1 500	1 540	160	NUKRU140	NUKRU140X	7.98	48
26 300	39 000	22 000	173 000	2 250	17 600	1 300	1 950	200	NUKRU150	NUKRU150X	9.70	52
27 900	41 000	24 000	194 000	2 450	19 800	1 200	2 480	250	NUKRU160	NUKRU160X	11.7	56
32 500	48 500	26 000	218 000	2 650	22 200	1 100	3 030	310	NUKRU170	NUKRU170X	13.9	60
37 500	56 500	27 900	253 000	2 840	25 800	1 000	3 670	375	NUKRU180	NUKRU180X	17.0	64

Inch series

Type CRV···X

Type CRV···XLL

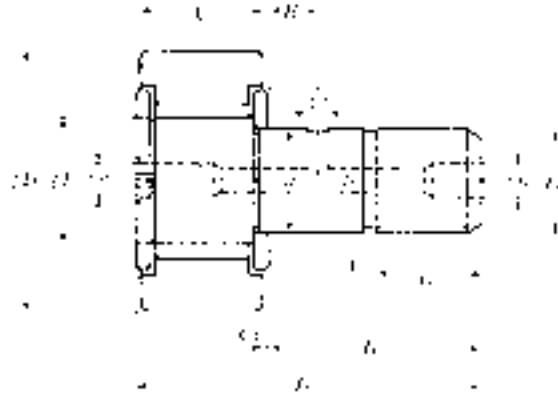

Type CR
(with cage)

D 12.700~152.400mm

Boundary dimensions													
D -0.025	C -0.130	d ₁ +0.025 0	F	mm (1/25.4mm)		G	G ₁	C ₁	n	B ₃	a	e	h
				B ₁	B ₂								
12.700(1/2)	8.731(1/32)	4.762(-)	6	23	12.7	NO-10-32UNF	6.4	0.8	3 ²⁾	-	-	10	1/8
	9.525(3/8)	4.762(-)	6	27	15.9	NO-10-32UNF	6.4	0.8	3 ²⁾	-	-	10	1/8
15.875(5/8)	10.319(13/32)	6.350(1/4)	8	27.8	15.9	1/4-28UNF	7.9	0.8	4 ²⁾	-	-	12.5	1/8
	11.112(7/16)	6.350(1/4)	8	31.8	19.1	1/4-28UNF	7.9	0.8	4 ²⁾	-	-	12.5	1/8
19.050(3/4)	12.700(1/2)	9.525(3/8)	12	36.5	22.2	3/8-24UNF	9.5	0.8	4	6.35	3	16.2	3/16
22.225(7/8)	12.700(1/2)	9.525(3/8)	12	36.5	22.2	3/8-24UNF	9.5	0.8	4	6.35	3	16.2	3/16
25.400(1)	15.875(5/8)	11.112(7/16)	13	42.8	25.4	7/16-20UNF	12.7	0.8	4	6.35	3	21	1/4
28.575(1 1/8)	15.875(5/8)	11.112(7/16)	13	42.8	25.4	7/16-20UNF	12.7	0.8	4	6.35	3	21	1/4
31.750(1 1/4)	19.050(3/4)	12.700(1/2)	16	52.4	31.8	1/2-20UNF	15.9	0.8	6	7.94	3	25	1/4
34.925(1 3/8)	19.050(3/4)	12.700(1/2)	16	52.4	31.8	1/2-20UNF	15.9	0.8	6	7.94	3	25	1/4
38.100(1 1/2)	22.225(7/8)	15.875(5/8)	20	61.9	38.1	5/8-18UNF	19.1	0.8	6	9.53	4	30	5/16
41.275(1 5/8)	22.225(7/8)	15.875(5/8)	20	61.9	38.1	5/8-18UNF	19.1	0.8	6	9.53	4	30	5/16
44.450(1 3/4)	25.400(1)	19.050(3/4)	25	71.4	44.4	3/4-16UNF	22.2	0.8	6	11.11	4	36.5	5/16
47.625(1 7/8)	25.400(1)	19.050(3/4)	25	71.4	44.4	3/4-16UNF	22.2	0.8	6	11.11	4	36.5	5/16
50.800(2)	31.750(1 1/4)	22.225(7/8)	30	84.1	50.8	7/8-14UNF	25.4	0.8	8	12.7	5	41.5	7/16
57.150(2 1/4)	31.750(1 1/4)	22.225(7/8)	30	84.1	50.8	7/8-14UNF	25.4	0.8	8	12.7	5	41.5	7/16

1) For bearing with cylindrical outer surface, the nominal number is followed by "X" code. In this case, the cylindrical bearing is manufactured with the tolerance for outer ring outer diameter *D* which conforms to JIS Class-0. Ex. CR10XLL



Type CR·LL
(with cage, sealed type)

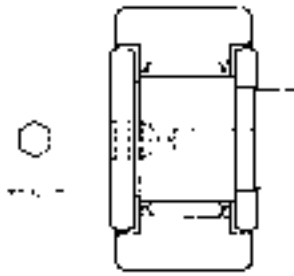

Type CR·H
(with hexagon hole)

Basic load ratings				Load ratings of truck				Limiting speeds		Maximum tightening torque		Bearing numbers		Mass (approx.)
dynamic		static		N		kgf		r/min		N·m	kgf·m	Type CRV·X ¹⁾	Type CRV·XLL ¹⁾	kg
C _r	C _{or}	C _r	C _{or}	Spherical outer ring	Cylindrical outer ring	Spherical outer ring	Cylindrical outer ring	grease	oil					
2 820	2 450	287	250	2 090	790	213	81	※20 000	※28 000	2	0.2	CR8T2	—	0.009
2 820	2 450	287	250	2 310	790	235	81	※20 000	※28 000	2	0.2	CR8-1T2	—	0.010
4 050	4 000	415	405	3 000	1 080	310	110	※18 000	※25 000	4	0.4	CR10	—	0.020
4 050	4 000	415	405	3 300	1 080	335	110	※18 000	※25 000	4	0.4	CR10-1	CR10-1LL	0.022
5 300	6 650	540	680	4 600	1 380	470	140	13 000	※16 000	13	1.3	CR12	CR12LL	0.037
5 300	6 650	540	680	5 350	1 710	545	174	13 000	※16 000	13	1.3	CR14	CR14LL	0.048
7 250	8 350	740	850	7 400	2 060	755	210	12 000	15 000	18	1.9	CR16	CR16LL	0.087
7 250	8 350	740	850	8 350	2 430	850	248	12 000	15 000	18	1.9	CR18	CR18LL	0.100
11 400	15 900	1 160	1 620	11 400	2 840	1 160	290	9 000	13 000	24	2.4	CR20	CR20LL	0.150
11 400	15 900	1 160	1 620	12 500	3 250	1 280	330	9 000	13 000	24	2.4	CR22	CR22LL	0.166
13 300	20 100	1 360	2 120	16 300	3 600	1 660	365	7 500	10 000	51	5.2	CR24	CR24LL	0.235
13 300	20 100	1 360	2 120	17 600	4 050	1 800	410	7 500	10 000	51	5.2	CR26	CR26LL	0.265
20 700	33 500	2 110	3 450	21 600	4 400	2 200	450	6 000	8 000	92	9.3	CR28	CR28LL	0.375
20 700	33 500	2 110	3 450	23 200	4 850	2 360	495	6 000	8 000	92	9.3	CR30	CR30LL	0.420
28 900	55 000	2 950	5 600	31 000	5 300	3 150	540	5 000	6 600	150	15	CR32	CR32LL	0.505
28 900	55 000	2 950	5 600	35 000	6 200	3 550	635	5 000	6 600	150	15	CR36	CR36LL	0.750

Note 2) Grease replenishing hole is provided at front side only (on left side-face in the above sketch). However, in the case with "hexagon hole" no grease replenishing hole is provided.

Remarks: For the cam follower with ※marked seal, the allowable running speed is approximately 10 000 r/min.

Inch series

Type CRV···X
Type CRV···XLL

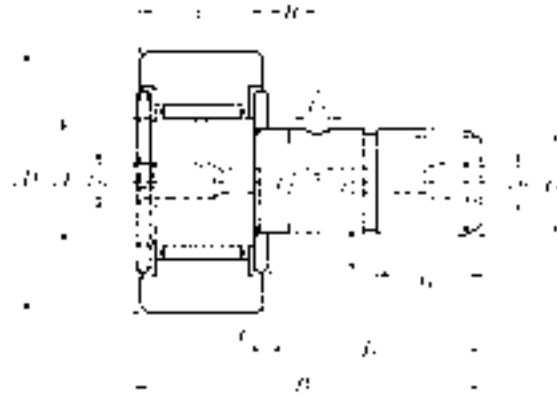

Type CRV···X
(Full-complement roller type)

D 12.700~152.400mm

Boundary dimensions													
D -0.025	C -0.130	d ₁ +0.025 0	F	mm (1/25.4mm)		G	G ₁	C ₁	n	B ₃	a	e	h
				B ₁	B ₂								
12.700(1/2)	8.731(1/32)	4.826(-)	5.75	23	12.7	NO-10-32UNF	6.4	0.8	3 ²⁾	-	-	10	1/8
	9.525(3/8)	4.826(-)	5.75	27	15.9	NO-10-32UNF	6.4	0.8	3 ²⁾	-	-	10	1/8
15.875(5/8)	10.319(13/32)	6.350(1/4)	8.11	27.8	15.9	1/4-28UNF	7.9	0.8	4 ²⁾	-	-	12.5	1/8
	11.112(7/16)	6.350(1/4)	8.11	31.8	19.1	1/4-28UNF	7.9	0.8	4 ²⁾	-	-	12.5	1/8
19.050(3/4)	12.700(1/2)	9.525(3/8)	11	36.5	22.2	3/8-24UNF	9.5	0.8	4	6.35	3	15.5	3/16
22.225(7/8)	12.700(1/2)	9.525(3/8)	11	36.5	22.2	3/8-24UNF	9.5	0.8	4	6.35	3	15.5	3/16
25.400(1)	15.875(5/8)	11.112(7/16)	14	43	25.4	7/16-20UNF	12.7	0.8	4	6.35	3	19.5	1/4
28.575(1 1/8)	15.875(5/8)	11.112(7/16)	14	43	25.4	7/16-20UNF	12.7	0.8	4	6.35	3	19.5	1/4
31.750(1 1/4)	19.050(3/4)	12.700(1/2)	18.47	52.4	31.8	1/2-20UNF	15.9	0.8	6	7.94	3	25	1/4
34.925(1 3/8)	19.050(3/4)	12.700(1/2)	18.47	52.4	31.8	1/2-20UNF	15.9	0.8	6	7.94	3	25	1/4
38.100(1 1/2)	22.225(7/8)	15.875(5/8)	21	61.9	38.1	5/8-18UNF	19.1	0.8	6	9.53	4	27	5/16
41.275(1 5/8)	22.225(7/8)	15.875(5/8)	21	61.9	38.1	5/8-18UNF	19.1	0.8	6	9.53	4	27	5/16
44.450(1 3/4)	25.400(1)	19.050(3/4)	24.65	71.4	44.5	3/4-16UNF	22.2	0.8	6	11.11	4	36.5	5/16
47.625(1 7/8)	25.400(1)	19.050(3/4)	24.65	71.4	44.5	3/4-16UNF	22.2	0.8	6	11.11	4	36.5	5/16
50.800(2)	31.750(1 1/4)	22.225(7/8)	26.71	84.1	50.8	7/8-14UNF	25.4	0.8	6	12.7	5	36.5	7/16
57.150(2 1/4)	31.750(1 1/4)	22.225(7/8)	26.71	84.1	50.8	7/8-14UNF	25.4	0.8	6	12.7	5	36.5	7/16
63.500(2 1/2)	38.100(1 1/2)	25.400(1)	31.15	96.8	57.2	1-14UNF	28.6	0.8	6	14.29	5	44	1/2
69.850(2 3/4)	38.100(1 1/2)	25.400(1)	31.15	96.8	57.2	1-14UNF	28.6	0.8	6	14.29	5	44	1/2
76.200(3)	44.450(1 3/4)	31.750(1 1/4)	36.85	109.5	63.5	1 1/4-12UNF	31.8	0.8	8	15.88	5	53	5/8
82.550(3 1/4)	44.450(1 3/4)	31.750(1 1/4)	36.85	109.5	63.5	1 1/4-12UNF	31.8	0.8	8	15.88	5	53	5/8
88.900(3 1/2)	50.800(2)	34.925(1 3/8)	44.5	122.2	69.9	1 3/8-12UNF	34.9	0.8	8	17.46	5	60	5/8
101.600(4)	57.150(2 1/4)	38.100(1 1/2)	44.5	147.6	88.9	1 1/2-12UNF	38.1	0.8	8	19.05	5	63	3/4
127.000(5)	69.850(2 3/4)	50.800(2)	68.7	200	128.6	2-12UNF	65.1	0.8	8	22.23	5	89	7/8
152.400(6)	82.550(3 1/4)	63.500(2 1/2)	81.35	236.6	152.4	2 1/2-12UNF	76.2	0.8	8	25.4	5	110	1

Note 1) For bearing with spherical outer surface, the nominal number is followed by "X" code. In this case, the spherical bearing (R=500) is manufactured with the tolerance 0,-0.05 for the outer ring outer diameter D.

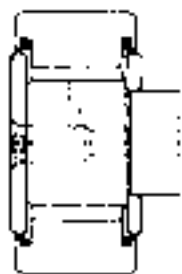

Type CRV·XLL
(Full-complement roller and sealed type)

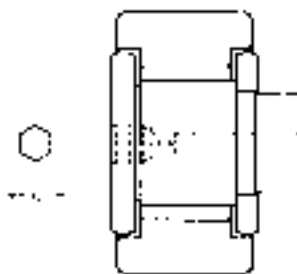

Type CRV·H
(with hexagon hole)

Basic load ratings				Load ratings of truck				Limiting speeds		Maximum tightening torque		Bearing numbers		Mass (approx.) kg Type CRV·X
dynamic N		static kgf		N		kgf		r/min		N·m	kgf·m	Type CRV·X ¹⁾	Type CRV·XLL ¹⁾	
<i>C_r</i>	<i>C_{0r}</i>	<i>C_r</i>	<i>C_{0r}</i>	Spherical outer ring	Cylindrical outer ring	Spherical outer ring	Cylindrical outer ring	grease	oil					
3 400	3 750	350	385	2 090	790	213	81	※17 000	※22 000	2	0.2	CRV8X	CRV8XLL	0.010
3 950	4 550	405	465	2 310	790	235	81	※17 000	※22 000	2	0.2	CRV8-1X	CRV8-1XLL	0.011
5 550	7 600	565	770	3 000	1 080	310	110	※12 000	※15 000	4	0.4	CRV10X	CRV10XLL	0.020
6 200	8 700	630	885	3 300	1 080	335	110	※12 000	※15 000	4	0.4	CRV10-1X	CRV10-1XLL	0.022
8 050	13 300	825	1 360	4 600	1 380	470	140	9 000	※11 000	13	1.3	CRV12X	CRV12XLL	0.038
8 050	13 300	825	1 360	5 350	1 710	545	174	9 000	※11 000	13	1.3	CRV14X	CRV14XLL	0.048
11 700	18 900	1 190	1 920	7 400	2 060	755	210	7 100	9 200	18	1.9	CRV16X	CRV16XLL	0.080
11 700	18 900	1 190	1 920	8 350	2 430	850	248	7 100	9 200	18	1.9	CRV18X	CRV18XLL	0.096
17 700	35 000	1 810	3 600	11 400	2 840	1 160	290	5 400	7 000	24	2.4	CRV20X	CRV20XLL	0.140
17 700	35 000	1 810	3 600	12 500	3 250	1 280	330	5 400	7 000	24	2.4	CRV22X	CRV22XLL	0.165
21 100	45 500	2 150	4 650	16 300	3 600	1 660	365	4 800	6 200	51	5.2	CRV24X	CRV24XLL	0.240
21 100	45 500	2 150	4 650	17 600	4 050	1 800	410	4 800	6 200	51	5.2	CRV26X	CRV26XLL	0.280
28 400	60 500	2 900	6 150	21 600	4 400	2 200	450	4 100	5 300	92	9.3	CRV28X	CRV28XLL	0.400
28 400	60 500	2 900	6 150	23 200	4 850	2 360	495	4 100	5 300	92	9.3	CRV30X	CRV30XLL	0.440
41 000	87 500	4 200	8 950	31 000	5 300	3 150	540	3 700	4 800	150	15	CRV32X	CRV32XLL	0.650
41 000	87 500	4 200	8 950	35 000	6 200	3 550	635	3 700	4 800	150	15	CRV36X	CRV36XLL	0.780
54 500	119 000	5 600	12 200	44 500	7 200	4 550	735	3 200	4 100	230	23	CRV40X	CRV40XLL	1.20
54 500	119 000	5 600	12 200	49 000	8 250	5 000	840	3 200	4 100	230	23	CRV44X	CRV44XLL	1.34
76 500	177 000	7 800	18 000	64 000	9 150	6 500	935	2 700	3 500	435	45	CRV48X	CRV48XLL	1.92
76 500	177 000	7 800	18 000	69 000	10 000	7 050	1 020	2 700	3 500	435	45	CRV52X	CRV52XLL	2.20
84 500	214 000	8 650	21 800	86 500	11 100	8 800	1 130	2 200	2 800	580	60	CRV56X	CRV56XLL	2.92
106 000	244 000	10 800	24 900	113 000	13 200	11 500	1 350	2 200	2 800	760	78	CRV64X	CRV64XLL	4.32
189 000	520 000	19 300	53 000	165 000	17 900	16 900	1 830	1 500	1 900	1 820	190	CRV80X	CRV80XLL	8.80
260 000	675 000	26 500	68 500	240 000	22 100	24 400	2 250	1 200	1 500	3 550	360	CRV96X	CRV96XLL	15.3

Note 2) Grease replenishing hole is provided at front side only (on left side-face in the above sketch). However, in the case with "hexagon hole" no grease replenishing hole is provided.

Remarks: For the cam follower with ※marked seal, the allowable running speed is approximately 10 000 r/min.

Thrust Roller Bearings

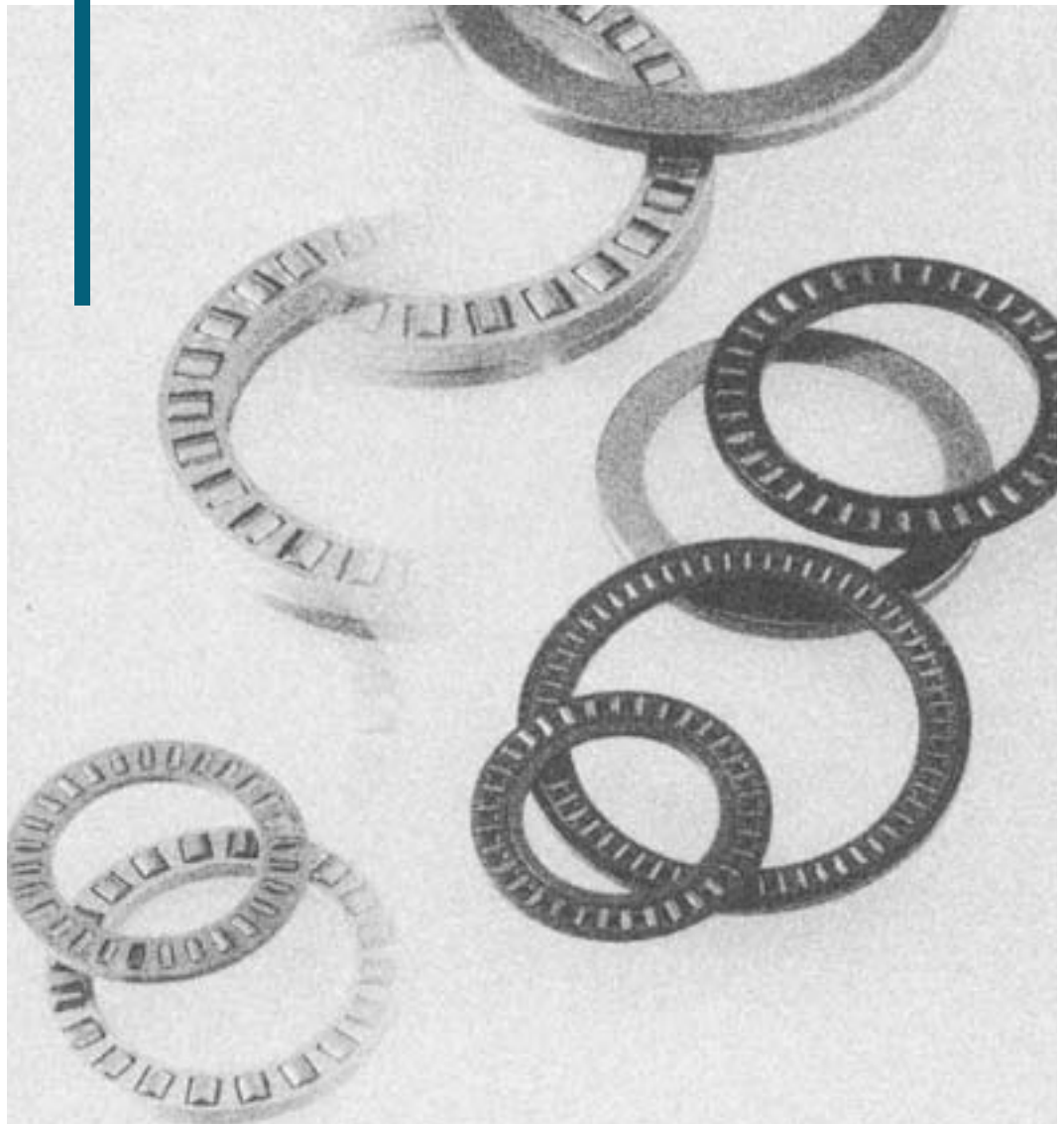

Thrust Roller Bearings

This thrust roller bearing composed of a thrust roller and cage assembly, wherein needle rollers or cylindrical rollers are configured radially in the cage, and a bearing ring of disc form is intended to support one-directional axial load.

In mounting, it is possible to use a shaft or a housing as the direct raceway surface without using the bearing

ring, whereby design of a low height and lightweight compact construction is enabled.

This type of thrust roller bearing results in slipping on raceway surface because theoretically it can't roll perfectly, but in most cases it is practically trouble-free and can rotate at comparatively high speed.

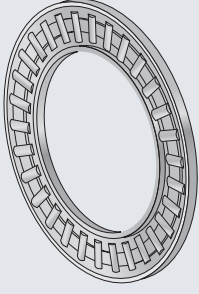
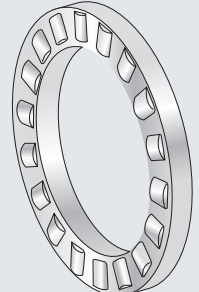
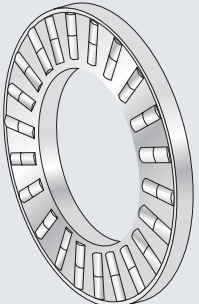
Bearing type	Cage type	Applied shaft dia (mm)	Composition of nominal number	Nominal number	Remarks
AXK 	Punched steel plate cage	$\phi 10 \sim \phi 120$	AXK 11 04 — Type code — Dimension series code — Bore diameter code	AXK1104	Possible to use in combination with AS type bearing ring.
	High tensile brass cage	$\phi 130 \sim \phi 160$			
K811 K812 	Standard type Polyamide resin cage	Type K811 $\phi 10 \sim \phi 120$	K8 11 10 T2 — Type code — Dimension series code — Bore diameter code — Tail code	K81110T2	Any bearing type with tail code T2, that is, with polyamide resin cage shall be used at allowable temperature 120°C and, under continuous running, at 100°C and less. Feel free to contact NTN for the detail of the punched steel plate cage. Possible to use in combination with GS and WS bearing rings. K811 conforms to the Dimension Series 11 specified in JIS B 1512. K812 conforms to the Dimension Series 12 specified in JIS B 1512.
		Type K812 $\phi 30 \sim \phi 80$			
	Aluminum alloy cage	Type K811 $\phi 130 \sim \phi 160$			
Type K812 $\phi 85 \sim \phi 140$					
Punched steel plate cage	$\phi 10 \sim \phi 90$	[Tail code] T2: resin cage JW: Punched steel plate cage			
K893 	Aluminum alloy cage	$\phi 30 \sim \phi 110$	K8 93 10 — Type code — Dimension series code — Bore diameter code	K89310	K893 conforms to the Dimension Series 93 specified in JIS B 1512.

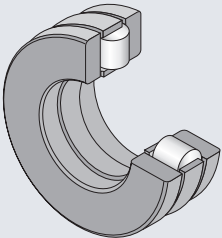
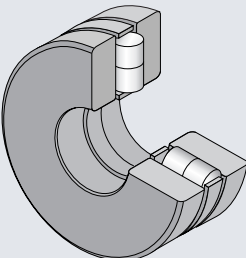
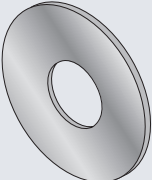
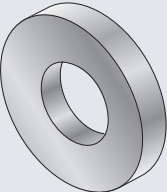
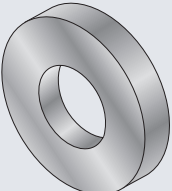
Bearing type		Applied shaft dia (mm)	Composition of nominal number	Nominal number	Remarks
811 812		$\phi 10 \sim \phi 160$	<p>8 11 10 T2</p> <ul style="list-style-type: none"> 8: Type code 11: Dimension series code 10: Bore diameter code T2: Tail code <p>[Tail code] T2: resin cage J: Punched steel plate cage</p>	8110T2	<p>Any bearing type with tail code T2, that is, with polyamide resin cage shall be used at allowable temperature 120°C and, under continuous running, at 100°C and less.</p> <p>WS and GS bearing rings are used in set.</p> <p>811 conforms to the Dimension Series 11 specified in JIS B 1512.</p> <p>812 conforms to the Dimension Series 12 specified in JIS B 1512.</p>
893		$\phi 30 \sim \phi 110$	<p>8 93 10</p> <ul style="list-style-type: none"> 8: Type code 93: Dimension series code 10: Bore diameter code 	89310	<p>WS and GS bearing rings are used in set.</p> <p>893 conforms to the Dimension Series 93 specified in JIS B 1512.</p>
AS		Punched steel plate cage $\phi 10 \sim \phi 130$	<p>AS 11 04</p> <ul style="list-style-type: none"> AS: Type code 11: Dimension series code 04: Bore diameter code 	AS1104	<p>Because of its 1mm thick steel plate ring, this thrust bearing needs adequate rigidity and profile accuracy of machine parts adjacent to the bearing.</p> <p>As an individual, on occasion this thrust bearing results in slight camber, but it is flattened when specific thrust load acts thereon, having no problem in practical use.</p>
WS811 WS812		Solid type bore guide $\phi 10 \sim \phi 160$	<p>WS8 11 04</p> <ul style="list-style-type: none"> WS8: Type code 11: Dimension series code 04: Bore diameter code 	WS81104	<p>Higher rigidity and higher running accuracy than AS bearing ring .</p>
GS811 GS812		Solid type outer guide $\phi 10 \sim \phi 160$	<p>GS8 11 04</p> <ul style="list-style-type: none"> GS8: Type code 11: Dimension series code 04: Bore diameter code 	GS81104	<p>Higher rigidity and higher running accuracy than AS bearing ring .</p>

Bearing accuracy

The respective dimensional accuracy, profile accuracy and running accuracy of thrust cylindrical roller bearings 811, 812 and 893 are as shown in **Table 4.4** of Section 4 "Bearing Accuracy" (page A-28).

The thrust roller and cage assemblies (**AXK, K811, K812, K893**) are machined with dimensional tolerance E11 for the bore diameter (D_{e1}) (E12 for bearing number with T2 code) and with dimensional tolerance c12 for the outer diameter (D_e) of **Type AXK** and a13 for the diameter (D_e) of **K811, K812 and K893**.

Raceway surface requirements:

Where the plane portion of a shaft/a housing is used as the direct raceway surface of thrust roller and cage assembly, the raceway surface must meet the requirements specified as a guideline in **Table 1**.

Table 1 Raceway surface requirements

Characteristics	Specified requirements
Perpendicularity (Max)	IT6 (IT4)
Surface roughness	0.2a
Surface hardness	HRC58~64
Effective hardened layer depth	Refer to Formula (7.1) on page A-39.

Reference : The parenthesized value shall be applied for high running accuracy.

Cage guiding

The thrust roller and cage assemblies (**AXK, K811, K812 and K893**) must be guided at either the bore side (shaft side) or the outer surface side (housing side) for in-running centering.

In general, the bore-side guide of low relative speed against the cage is mostly used. It should be used particularly for high speed running. The dimensional tolerances for shaft and housing, when the cage is guided thereby, shall be h8 for shaft diameter (bore guide) and H9 for housing bore diameter (outer surface guide) respectively, which of the guide surface shall be fine-finished by grinding.

Bearing fit in bearing ring

Table 2 shows the tolerances for fitting of the thrust bearing rings (**AS, WS and GS**) on shaft or in housing.

Table 2 Bearing ring fit in shaft and housing

Bearing ring	Shaft	Housing
Series AS	h10	H11
Series WS	h6	—
Series GS	—	H7

Mounting related dimensions

The dimensions related to fitting of **WS** and **GS** bearing rings on shaft and in housing are as described in applicable Dimensions Table.

The fitting surface of **AS** bearing ring must be flat and have the rigidity sufficient to support thrust load throughout its entire surface.

Type AXK11
 Type AS11
 Type WS811
 Type GS811

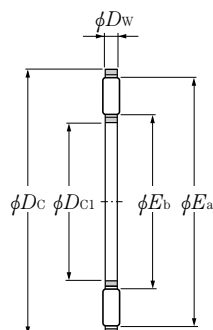

Type AXK
 (Thrust needle roller
 and cage assy)

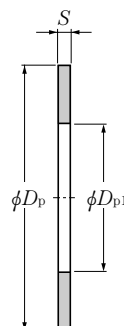

AS bearing ring
 (washer)

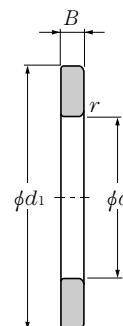

WS bearing ring
 (Inner ring)

D_{c1} 10~140mm

Boundary dimensions											Basic load ratings				
mm											dynamic	static	dynamic	static	
D_{c1}	D_c	D_w	D_p	D_{p1}	S ²⁾	d	d_1	D	D_1	B	$r_{s \min}$ ¹⁾	N	N	kgf	kgf
E11	c12	$0_{-0.01}$	e13	E12	0.05		$-0.2_{-0.5}$		$+0.5_{+0.2}$			C_a	C_{oa}	C_a	C_{oa}
10	24	2	24	10	1	10	24	24	10	$2.75_{-0.060}^0$	0.3	9 150	25 300	935	2 580
12	26	2	26	12	1	12	26	26	12	$2.75_{-0.060}^0$	0.3	9 850	28 900	1 010	2 940
15	28	2	28	15	1	15	28	28	16	$2.75_{-0.060}^0$	0.3	11 300	36 000	1 150	3 700
17	30	2	30	17	1	17	30	30	18	$2.75_{-0.060}^0$	0.3	11 900	39 500	1 220	4 050
20	35	2	35	20	1	20	35	35	21	$2.75_{-0.060}^0$	0.3	13 200	46 500	1 340	4 750
25	42	2	42	25	1	25	42	42	26	$3_{-0.060}^0$	0.6	14 600	58 000	1 490	5 900
30	47	2	47	30	1	30	47	47	32	$3_{-0.060}^0$	0.6	16 300	69 500	1 660	7 100
35	52	2	52	35	1	35	52	52	37	$3.5_{-0.075}^0$	0.6	17 800	81 500	1 820	8 300
40	60	3	60	40	1	40	60	60	42	$3.5_{-0.075}^0$	0.6	27 400	110 000	2 790	11 300
45	65	3	65	45	1	45	65	65	47	$4_{-0.075}^0$	0.6	29 800	128 000	3 050	13 100
50	70	3	70	50	1	50	70	70	52	$4_{-0.075}^0$	0.6	31 500	143 000	3 250	14 500
55	78	3	78	55	1	55	78	78	57	$5_{-0.075}^0$	0.6	38 000	186 000	3 850	19 000
60	85	3	85	60	1	60	85	85	62	$4.75_{-0.075}^0$	1	44 500	234 000	4 550	23 900
65	90	3	90	65	1	65	90	90	67	$5.25_{-0.075}^0$	1	46 500	254 000	4 750	25 900
70	95	4	95	70	1	70	95	95	72	$5.25_{-0.075}^0$	1	53 500	253 000	5 500	25 800
75	100	4	100	75	1	75	100	100	77	$5.75_{-0.075}^0$	1	55 000	266 000	5 650	27 100
80	105	4	105	80	1	80	105	105	82	$5.75_{-0.075}^0$	1	56 500	279 000	5 750	28 400
85	110	4	110	85	1	85	110	110	87	$5.75_{-0.075}^0$	1	57 500	291 000	5 900	29 700
90	120	4	120	90	1	90	120	120	92	$6.5_{-0.090}^0$	1	71 000	390 000	7 250	39 500
100	135	4	135	100	1	100	135	135	102	$7_{-0.090}^0$	1	90 500	550 000	9 200	56 500
110	145	4	145	110	1	110	145	145	112	$7_{-0.090}^0$	1	93 500	590 000	9 550	60 500
120	155	4	155	120	1	120	155	155	122	$7_{-0.090}^0$	1	99 000	650 000	10 100	66 500
130	170	5	170	130	1	130	170	170	132	$9_{-0.090}^0$	1	140 000	900 000	14 300	92 000
140	180	5	180	140	1	140	178	180	142	$9.5_{-0.090}^0$	1	145 000	960 000	14 800	97 500

Note 1) Allowable minimum chamfer dimension r .

2) Subject to measured thrust load of 20kg or more.

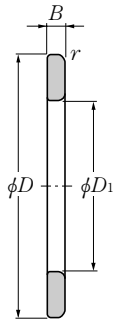

**GS bearing ring
(Outer ring)**

Limiting speeds		Bearing numbers				Reference dimensions		Mass			
grease	r/min	thrust needle roller and cage assembly	washer	inner ring	outer ring	mm		kg (approx.)			
	oil					E_b	E_a	AXK11	AS11	WS811 GS811	
	3 500	14 000	AXK1100	AS1100	WS81100	GS81100	12.3	21.7	0.0028	0.003	0.008
	3 300	13 000	AXK1101	AS1101	WS81101	GS81101	14.3	23.7	0.003	0.0033	0.009
	2 800	11 000	AXK1102	AS1102	WS81102	GS81102	17.2	26.5	0.0035	0.0035	0.01
	2 500	10 000	AXK1103	AS1103	WS81103	GS81103	19.2	28.5	0.004	0.0038	0.011
	2 100	8 500	AXK1104	AS1104	WS81104	GS81104	21.3	31.3	0.005	0.0051	0.014
	1 800	7 000	AXK1105	AS1105	WS81105	GS81105	29.5	39.4	0.007	0.007	0.021
	1 500	6 000	AXK1106	AS1106	WS81106	GS81106	34.5	44.4	0.008	0.008	0.025
	1 400	5 500	AXK1107	AS1107	WS81107	GS81107	39.5	49.4	0.01	0.0091	0.033
	1 200	4 700	AXK1108	AS1108	WS81108	GS81108	44.2	56.2	0.0185	0.0123	0.044
	1 100	4 300	AXK1109	AS1109	WS81109	GS81109	50.5	62.4	0.0205	0.0136	0.055
	1 000	3 900	AXK1110	AS1110	WS81110	GS81110	55.5	67.4	0.0235	0.0148	0.06
	900	3 500	AXK1111	AS1111	WS81111	GS81111	61.0	74.9	0.0308	0.0189	0.095
	800	3 200	AXK1112	AS1112	WS81112	GS81112	66.0	81.9	0.0390	0.0223	0.101
	750	3 000	AXK1113	AS1113	WS81113	GS81113	71.0	86.9	0.04	0.0239	0.125
	750	2 900	AXK1114	AS1114	WS81114	GS81114	75.5	91.4	0.06	0.0254	0.134
	700	2 700	AXK1115	AS1115	WS81115	GS81115	80.5	96.4	0.061	0.027	0.155
	650	2 600	AXK1116	AS1116	WS81116	GS81116	84.4	100.3	0.063	0.0284	0.163
	600	2 400	AXK1117	AS1117	WS81117	GS81117	90.5	106.4	0.0668	0.0301	0.175
	600	2 300	AXK1118	AS1118	WS81118	GS81118	96.5	116.4	0.086	0.0388	0.25
	500	2 000	AXK1120	AS1120	WS81120	GS81120	107.5	131.4	0.112	0.0505	0.35
	480	1 900	AXK1122	AS1122	WS81122	GS81122	115.5	139.4	0.122	0.0549	0.385
	430	1 700	AXK1124	AS1124	WS81124	GS81124	125.5	149.4	0.131	0.0592	0.415
	400	1 600	AXK1126	AS1126	WS81126	GS81126	136.0	164.0	0.205	0.074	0.663
	380	1 500	AXK1128	AS1128	WS81128	GS81128	146.0	174.0	0.219	0.079	0.749

Type AXK11
Type AS11
Type WS811
Type GS811

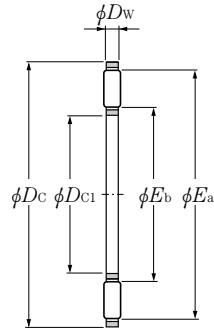

Type AXK
(Thrust needle roller and cage assy)

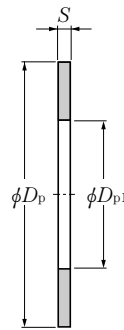

AS bearing ring
(washer)

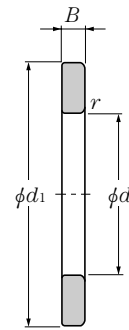

WS bearing ring
(Inner ring)

D_{c1} 150~160mm

Boundary dimensions											Basic load ratings					
mm											dynamic	static	dynamic	static		
D_{c1}	D_c	D_w	D_p	D_{p1}	S 2)	d	d_1	D	D_1	B	$r_{s \min}$ 1)	N	N	kgf	kgf	
E11	c12	$\begin{smallmatrix} 0 \\ -0.01 \end{smallmatrix}$	e13	E12	0.05		$\begin{smallmatrix} -0.2 \\ -0.5 \end{smallmatrix}$		$\begin{smallmatrix} +0.5 \\ +0.2 \end{smallmatrix}$			C_a	C_{oa}	C_a	C_{oa}	
150	190	5	190	150	1	150	188	190	152	9.5	$\begin{smallmatrix} 0 \\ -0.090 \end{smallmatrix}$	1	149 000	1 020 000	15 200	104 000
160	200	5	200	160	1	160	198	200	162	9.5	$\begin{smallmatrix} 0 \\ -0.090 \end{smallmatrix}$	1	154 000	1 070 000	15 700	110 000

Note 1) Allowable minimum chamfer dimension r .
 2) Subject to measured thrust load of 20kg or more.

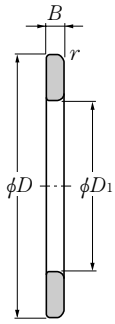

**GS bearing ring
(Outer ring)**

Limiting speeds		Bearing numbers				Reference dimensions		Mass		
grease	r/min	thrust needle roller and cage assembly	washer	inner ring	outer ring	mm		kg (approx.)		
	oil					E_b	E_a	AXK11	AS11	WS811 GS811
350	1 400	AXK1130	AS1130	WS81130	GS81130	156.0	184.2	0.232	0.084	0.796
330	1 300	AXK1132	AS1132	WS81132	GS81132	166.0	194.2	0.246	0.089	0.842

Type 811
Type 812
Type 893

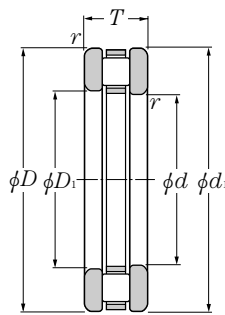

**Type 811
Type 812
(Bearing)**

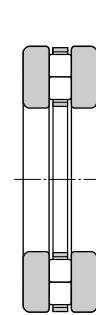

**Type 893
(Bearing)**

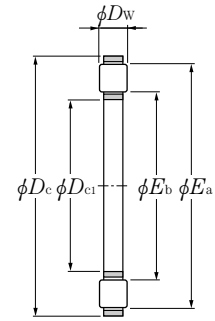

**Type K811, type K812
(Thrust needle roller
and cage assy)**

d 10~60mm

Boundary dimensions										Basic load ratings				Limiting speeds		
d	D	d_1 -0.2 -0.5	D_1 +0.5 +0.2	mm						$r_{s \min}^{1)}$	dynamic C_a	static N C_{oa}	dynamic kgf C_a	static C_{oa}	r/min	
				T	$D_{ci}^{2)}$ E11	D_c a13	D_w 0 -0.010	B h11	grease						oil	
10	24	24	10	9	10	24	3.5	2.75	0.3	10 800	21 500	1 110	2 190	3 400	13 000	
12	26	26	12	9	12	26	3.5	2.75	0.3	11 500	23 900	1 170	2 430	3 000	12 000	
15	28	28	16	9	15	28	3.5	2.75	0.3	12 900	28 600	1 310	2 920	2 800	11 000	
17	30	30	18	9	17	30	3.5	2.75	0.3	13 400	31 000	1 370	3 150	2 500	10 000	
20	35	35	21	10	20	35	4.5	2.75	0.3	20 200	46 500	2 060	4 700	2 100	8 500	
25	42	42	26	11	25	42	5	3	0.6	27 300	68 000	2 780	6 900	1 800	7 000	
30	47	47	32	11	30	47	5	3	0.6	27 800	72 500	2 840	7 400	1 500	6 000	
	52	52	32	16	30	52	7.5	4.25	0.6	53 000	129 000	5 450	13 100	1 500	6 000	
	60	60	32	18	30	60	5.5	6.25	1	54 000	166 000	5 500	16 900	1 300	5 000	
35	52	52	37	12	35	52	5	3.5	0.6	31 000	87 000	3 150	8 900	1 400	5 500	
	62	62	37	18	35	62	7.5	5.25	1	54 500	139 000	5 550	14 200	1 200	4 900	
	68	68	37	20	35	68	6	7	1	66 000	214 000	6 750	21 800	1 200	4 600	
40	60	60	42	13	40	60	6	3.5	0.6	43 000	121 000	4 350	12 400	1 200	4 800	
	68	68	42	19	40	68	9	5	1	74 500	190 000	7 600	19 400	1 100	4 400	
	78	78	42	22	40	78	7	7.5	1	85 000	277 000	8 700	28 300	1 000	4 000	
45	65	65	47	14	45	65	6	4	0.6	45 500	135 000	4 650	13 800	1 100	4 400	
	73	73	47	20	45	73	9	5.5	1	82 000	222 000	8 350	22 600	1 000	4 100	
	85	85	47	24	45	85	7.5	8.25	1	102 000	345 000	10 400	35 000	900	3 600	
50	70	70	52	14	50	70	6	4	0.6	48 000	150 000	4 900	15 300	1 000	4 000	
	78	78	52	22	50	78	9	6.5	1	85 000	238 000	8 650	24 200	950	3 800	
	95	95	52	27	50	95	8	9.5	1.1	125 000	445 000	12 700	45 000	800	3 200	
55	78	78	57	16	55	78	6	5	0.6	62 500	215 000	6 350	21 900	900	3 600	
	90	90	57	25	55	90	11	7	1	121 000	340 000	12 300	34 500	830	3 300	
	105	105	57	30	55	105	9	10.5	1.1	158 000	570 000	16 100	58 000	730	2 900	
60	85	85	62	17	60	85	7.5	4.75	1	69 000	215 000	7 000	21 900	830	3 300	
	95	95	62	26	60	95	11	7.5	1	125 000	365 000	12 800	37 000	780	3 100	
	110	110	62	30	60	110	9	10.5	1.1	162 000	600 000	16 500	61 500	680	2 700	

Note 1) Allowable minimum chamfer dimension r .
2) The dimensional tolerance for a bearing with a T2 suffix is E12.

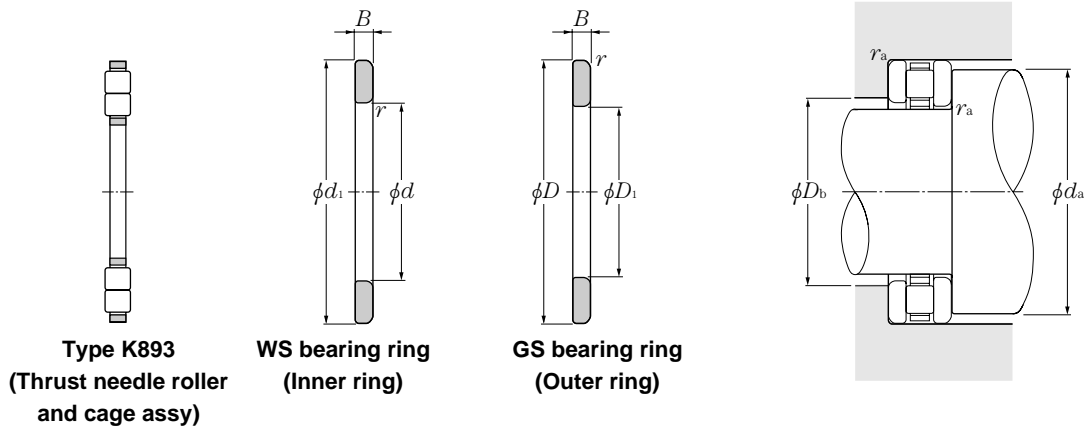

Type K893
(Thrust needle roller
and cage assy)

WS bearing ring
(Inner ring)

GS bearing ring
(Outer ring)

Bearing numbers				Reference dimensions mm		Abutment dimensions mm			Mass kg		
bearing	thrust cylindrical roller and cage assembly	inner ring	outer ring	E_b	E_a	d_a min	D_b max	r_{as} max	811	K811	WS GS
									812	K812	
									893	K893	
81100T2	K81100T2	WS81100	GS81100	13.5	21.3	21	14	0.3	0.0195	0.0035	0.008
81101T2	K81101T2	WS81101	GS81101	15.5	23.3	23	16	0.3	0.022	0.004	0.009
81102T2	K81102T2	WS81102	GS81102	17.2	25.0	25	18	0.3	0.026	0.006	0.010
81103T2	K81103T2	WS81103	GS81103	19.2	27.0	27	20	0.3	0.030	0.008	0.011
81104T2	K81104T2	WS81104	GS81104	22.4	32.3	32	23	0.3	0.040	0.012	0.014
81105T2	K81105T2	WS81105	GS81105	27.6	38.7	39	28	0.6	0.060	0.018	0.021
81106T2	K81106T2	WS81106	GS81106	33.1	43.9	44	33	0.6	0.070	0.020	0.025
81206T2	K81206T2	WS81206	GS81206	32.8	49.0	48	33	0.6	0.140	0.050	0.045
89306	K89306	WS89306	GS89306	34.0	56.4	56	34	1	0.250	0.046	0.100
81107T2	K81107T2	WS81107	GS81107	38.0	48.9	49	38	0.6	0.090	0.024	0.033
81207T2	K81207T2	WS81207	GS81207	39.8	56.0	56	41	1	0.235	0.065	0.085
89307	K89307	WS89307	GS89307	40.0	64.4	64	40	1	0.360	0.064	0.150
81108T2	K81108T2	WS81108	GS81108	43.2	56.4	56	44	0.6	0.135	0.035	0.044
81208T2	K81208T2	WS81208	GS81208	43.7	62.9	63	44	1	0.265	0.085	0.090
89308	K89308	WS89308	GS89308	46.0	74.4	74	46	1	0.520	0.100	0.210
81109T2	K81109T2	WS81109	GS81109	48.4	61.6	61	49	0.6	0.150	0.040	0.055
81209T2	K81209T2	WS81209	GS81209	48.8	68.0	68	49	1	0.310	0.100	0.105
89309	K89309	WS89309	GS89309	50.9	81.3	81	51	1	0.670	0.140	0.270
81110T2	K81110T2	WS81110	GS81110	53.2	66.4	66	54	0.6	0.165	0.045	0.060
81210T2	K81210T2	WS81210	GS81210	53.7	73.1	73	54	1	0.385	0.105	0.140
89310	K89310	WS89310	GS89310	58.0	90.4	90	58	1	0.940	0.180	0.380
81111T2	K81111T2	WS81111	GS81111	57.8	75.2	75	58	0.6	0.250	0.060	0.095
81211T2	K81211T2	WS81211	GS81211	60.1	83.4	83	61	1	0.610	0.190	0.210
89311	K89311	WS89311	GS89311	63.9	100.3	100	64	1	1.270	0.240	0.520
81112T2	K81112T2	WS81112	GS81112	63.7	80.1	80	65	1	0.285	0.083	0.101
81212T2	K81212T2	WS81212	GS81212	64.9	88.4	88	66	1	0.660	0.200	0.230
89312	K89312	WS89312	GS89312	68.9	105.3	105	69	1	1.350	0.250	0.550

Type 811
Type 812
Type 893

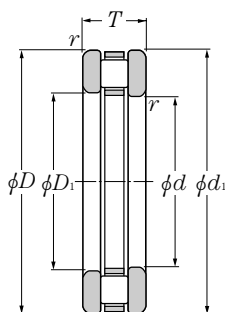

**Type 811
Type 812
(Bearing)**

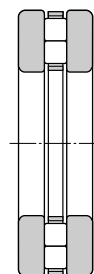

**Type 893
(Bearing)**

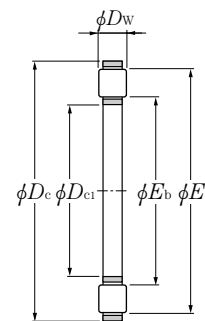

**Type K811, type K812
(Thrust needle roller
and cage assy)**

d 65~130mm

Boundary dimensions										Basic load ratings				Limiting speeds		
d	D	d ₁ -0.2 -0.5	D ₁ +0.5 +0.2	mm						r _s min ¹⁾	dynamic N	static N	dynamic kgf	static kgf	r/min	
				T	D _{c1} E11	D _c a13	D _w 0 -0.010	B h11	grease						oil	
65	90	90	67	18	65	90	7.5	5.25	1	73 000	236 000	7 400	24 100	780	3 100	
	100	100	67	27	65	100	11	8	1	130 000	385 000	13 200	39 500	730	2 900	
	115	115	67	30	65	115	9	10.5	1.1	166 000	635 000	17 000	64 500	650	2 600	
70	95	95	72	18	70	95	7.5	5.25	1	76 500	257 000	7 800	26 200	730	2 900	
	105	105	72	27	70	105	11	8	1	134 000	410 000	13 700	42 000	680	2 700	
	125	125	72	34	70	125	10	12	1.1	205 000	790 000	20 900	81 000	600	2 400	
75	100	100	77	19	75	100	7.5	5.75	1	78 000	268 000	7 950	27 300	680	2 700	
	110	110	77	27	75	110	11	8	1	138 000	435 000	14 100	44 500	650	2 600	
	135	135	77	36	75	135	11	12.5	1.5	239 000	920 000	24 400	94 000	550	2 200	
80	105	105	82	19	80	105	7.5	5.75	1	79 500	279 000	8 100	28 400	650	2 600	
	115	115	82	28	80	115	11	8.5	1	142 000	460 000	14 500	47 000	630	2 500	
	140	140	82	36	80	140	11	12.5	1.5	246 000	970 000	25 100	98 500	530	2 100	
85	110	110	87	19	85	110	7.5	5.75	1	83 000	300 000	8 450	30 500	630	2 500	
	125	125	88	31	85	125	12	9.5	1	169 000	550 000	17 200	56 500	580	2 300	
	150	150	88	39	85	150	12	13.5	1.5	281 000	1 100 000	28 600	113 000	500	2 000	
90	120	120	92	22	90	120	9	6.5	1	112 000	395 000	11 400	40 500	580	2 300	
	135	135	93	35	90	135	14	10.5	1.1	213 000	680 000	21 700	69 500	530	2 100	
	155	155	93	39	90	155	12	13.5	1.5	289 000	1 160 000	29 500	118 000	480	1 900	
100	135	135	102	25	100	135	11	7	1	158 000	555 000	16 100	57 000	500	2 000	
	150	150	103	38	100	150	15	11.5	1.1	243 000	795 000	24 800	81 000	480	1 900	
	170	170	103	42	100	170	13	14.5	1.5	335 000	1 370 000	34 500	140 000	430	1 700	
110	145	145	112	25	110	145	11	7	1	165 000	605 000	16 800	61 500	480	1 900	
	160	160	113	38	110	160	15	11.5	1.1	259 000	885 000	26 400	90 000	450	1 800	
	190	190	113	48	110	190	15	16.5	2	430 000	1 770 000	44 000	180 000	400	1 600	
120	155	155	122	25	120	155	11	7	1	172 000	655 000	17 500	66 500	450	1 800	
	170	170	123	39	120	170	15	12	1.1	264 000	930 000	26 900	94 500	430	1 700	
130	170	170	132	30	130	170	12	9	1	197 000	755 000	20 100	77 000	400	1 600	
	190	187	133	45	130	190	19	13	1.5	360 000	1 210 000	36 500	123 000	380	1 500	

Note 1) Allowable minimum chamfer dimension r'.
2) The dimensional tolerance for a bearing with a T2 suffix is E12.

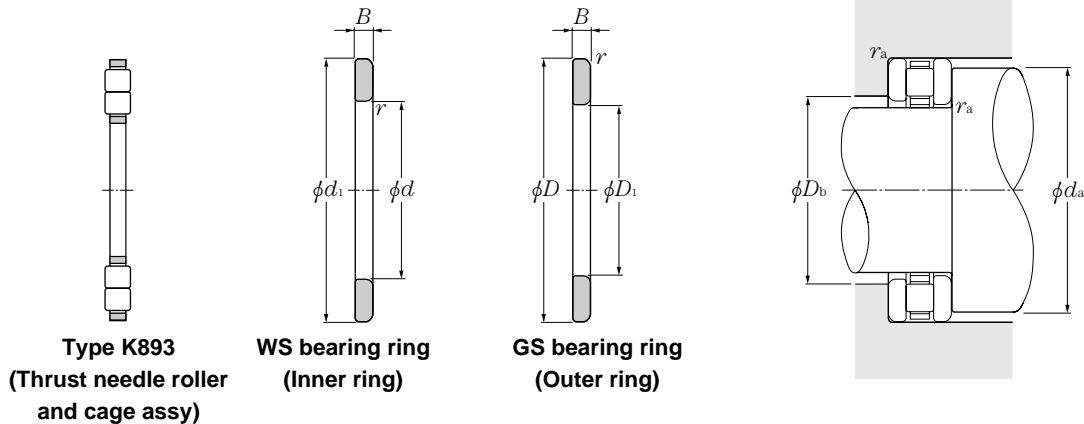

Type K893
(Thrust needle roller
and cage assy)

WS bearing ring
(Inner ring)

GS bearing ring
(Outer ring)

Bearing numbers				Reference dimensions mm		Abutment dimensions mm			Mass kg		
bearing	thrust cylindrical roller and cage assembly	inner ring	outer ring	E_b	E_a	d_a min	D_b max	r_{as} max	811	K811	WS
									812	K812	
89313	K89313	WS89313	GS89313	73.9	110.3	110	74	1	893	K893	GS
81113T2	K81113T2	WS81113	GS81113	68.8	85.2	85	70	1	0.340	0.090	0.125
81213T2	K81213T2	WS81213	GS81213	69.9	93.3	93	71	1	0.775	0.215	0.280
81114T2	K81114T2	WS81114	GS81114	73.7	90.1	90	74	1	0.365	0.097	0.135
81214T2	K81214T2	WS81214	GS81214	75.0	98.4	98	76	1	0.815	0.225	0.295
89314	K89314	WS89314	GS89314	79.8	120.2	120	80	1	1.930	0.340	0.800
81115T2	K81115T2	WS81115	GS81115	78.7	95.1	95	80	1	0.425	0.115	0.155
81215T2	K81215T2	WS81215	GS81215	80.1	103.7	103	81	1	0.860	0.240	0.310
89315	K89315	WS89315	GS89315	84.7	129.2	129	85	1.5	2.410	0.470	0.970
81116T2	K81116T2	WS81116	GS81116	83.7	100.1	100	85	1	0.445	0.119	0.165
81216T2	K81216T2	WS81216	GS81216	84.8	108.4	106	86	1	0.950	0.250	0.350
89316	K89316	WS89316	GS89316	89.8	134.2	134	90	1.5	2.530	0.490	1.020
81117T2	K81117T2	WS81117	GS81117	88.7	105.3	105	89	1	0.475	0.125	0.175
81217	K81217	WS81217	GS81217	92.2	116.9	116	92	1	1.280	0.300	0.490
89317	K89317	WS89317	GS89317	95.8	144.2	144	96	1.5	3.140	0.590	1.280
81118T2	K81118T2	WS81118	GS81118	94.7	114.3	114	95	1	0.670	0.170	0.250
81218J	K81218J	WS81218	GS81218	97.9	126.7	126	97	1	1.820	0.540	0.640
89318	K89318	WS89318	GS89318	100.8	149.2	149	101	1.5	3.280	0.620	1.330
81120T2	K81120T2	WS81120	GS81120	105.1	128.7	128	106	1	1.000	0.300	0.350
81220	K81220	WS81220	GS81220	109.2	140.0	139	109	1	2.240	0.620	0.810
89320	K89320	WS89320	GS89320	110.6	163.0	163	110	1.5	4.190	0.810	1.690
81122T2	K81122T2	WS81122	GS81122	115.0	138.8	138	116	1	1.100	0.325	0.385
81222	K81222	WS81222	GS81222	119.2	150.0	149	119	1	2.450	0.685	0.880
89322	K89322	WS89322	GS89322	122.5	183.0	183	122	2	6.030	1.150	2.440
81124T2	K81124T2	WS81124	GS81124	125.0	148.8	148	126	1	1.170	0.340	0.415
81224	K81224	WS81224	GS81224	129.2	160.0	159	129	1	2.690	0.730	0.980
81126	K81126	WS81126	GS81126	137.7	162.4	162	137	1	1.740	0.415	0.663
81226	K81226	WS81226	GS81226	140.1	179.0	173	140	1.5	4.200	1.140	1.530

Type 811

Type 812

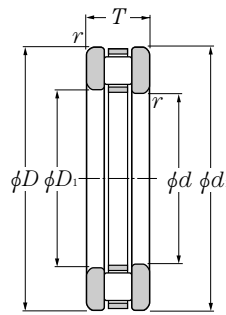

**Type 811
Type 812
(Bearing)**

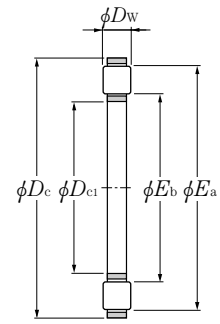

**Type K811, type K812
(Thrust needle roller
and cage assy)**

d 140~160mm

d	Boundary dimensions									Basic load ratings				Limiting speeds		
	D	d_1 $\begin{smallmatrix} -0.2 \\ -0.5 \end{smallmatrix}$	D_1 $\begin{smallmatrix} +0.5 \\ +0.2 \end{smallmatrix}$	mm					B h11	r_s min ¹⁾	dynamic	static	dynamic	static	grease	oil
				T	D_{c1} E11	D_c a13	D_w $\begin{smallmatrix} 0 \\ -0.010 \end{smallmatrix}$	N			N	kgf	kgf			
140	180	178	142	31	140	180	12	9.5	1	206 000	815 000	21 000	83 000	380	1 500	
	200	197	143	46	140	200	19	13.5	1.5	370 000	1 280 000	38 000	130 000	350	1 400	
150	190	188	152	31	150	190	12	9.5	1	214 000	870 000	21 800	89 000	350	1 400	
160	200	198	162	31	160	200	12	9.5	1	221 000	930 000	22 600	95 000	330	1 300	

Note 1) Allowable minimum chamfer dimension r' .

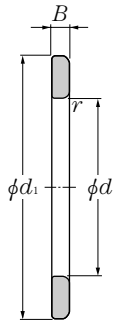

**WS bearing ring
(Inner ring)**

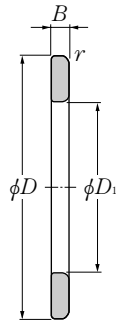

**GS bearing ring
(Outer ring)**

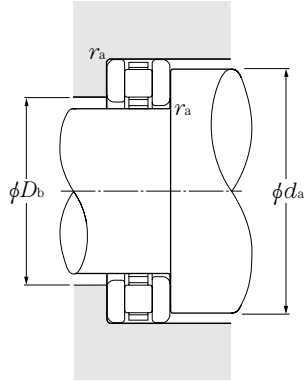

Bearing numbers				Reference dimensions mm		Abutment dimensions mm			Mass kg		
bearing	thrust cylindrical roller and cage assembly	inner ring	outer ring	E_b	E_a	d_a min	D_b max	r_{as} max	811	K811	WS
									812	K812	GS
									893	K893	
81128	K81128	WS81128	GS81128	147.8	172.5	172	147	1	1.950	0.450	0.750
81228	K81228	WS81228	GS81228	150.1	189.0	188	150	1.5	4.570	1.200	1.690
81130	K81130	WS81130	GS81130	157.7	182.4	182	157	1	2.070	0.470	0.800
81132	K81132	WS81132	GS81132	167.8	192.5	192	167	1	2.190	0.500	0.840

COMPONENTS

Needle Rollers/Snap Rings/Seals

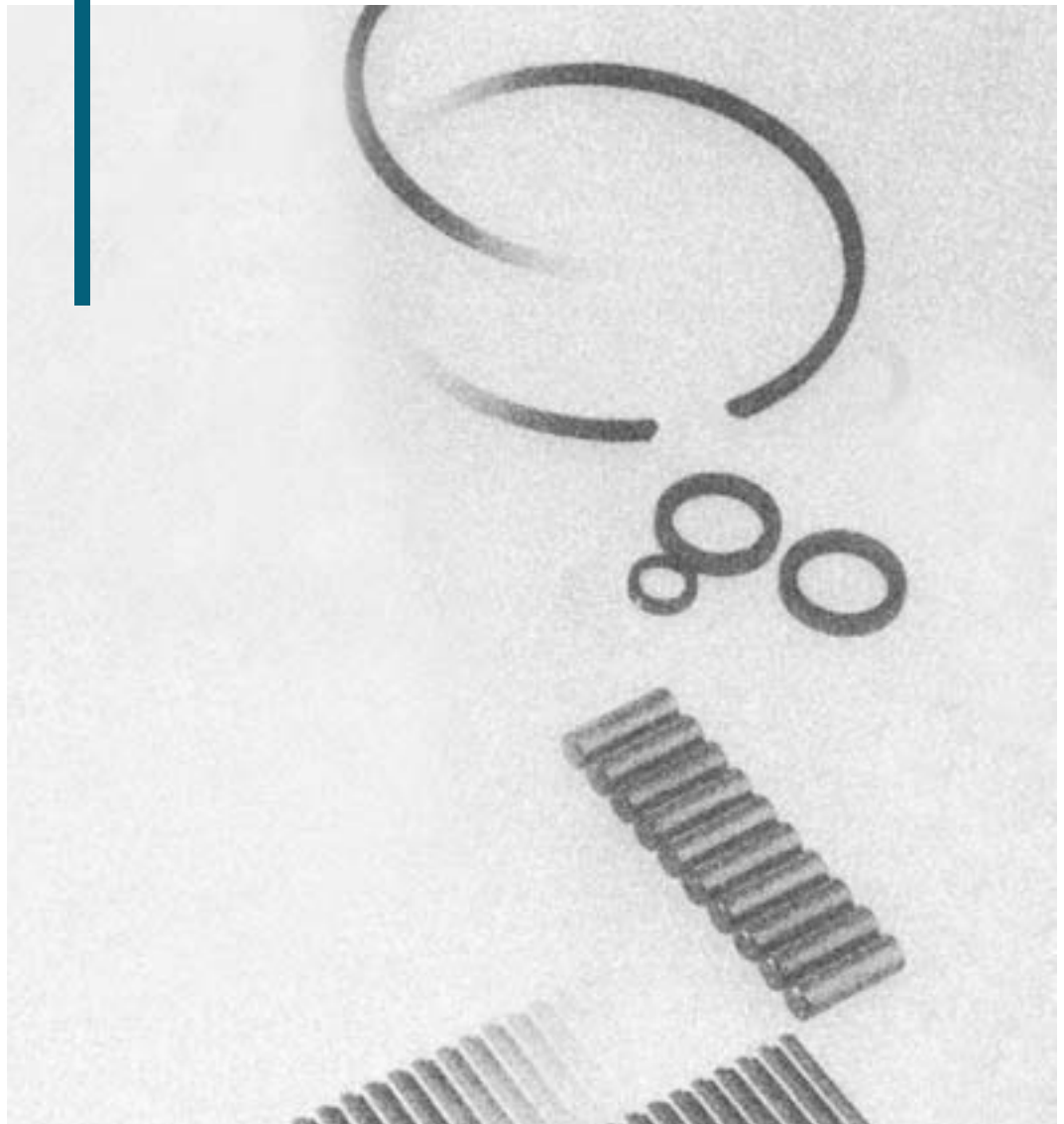



Needle Rollers

NTN needle rollers are all made of high carbon chrome bearing steel, fine-finished by grinding and polishing after heat-treated, and the hardness thereof ranges from HRC60 to 65. These needle rollers are supplied as not only rolling element but also pin and shaft individuals.

End face profile of needle roller

F-type needle roller bearing with flat end face is standard type, while A-type with round end face is semi-standard type. In addition to these two types, another needle roller type (nominal number with tail code E) capable of damping edge load is also available. Feel free to contact NTN for the detail thereof.

Table 1 End face profile

Type	Name	Profile
F	Flat	
A	Round	

Composition of nominal code

The nominal number comprises type code (end face profile), dimension code [diameter (D_w) \times length (L_w)] and tail code.

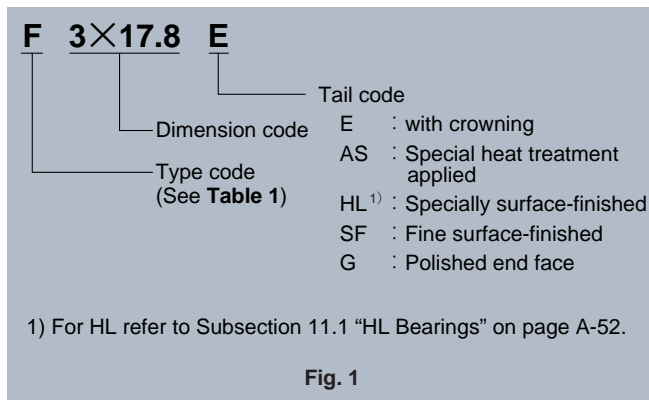

Needle roller tolerances

Any needle rollers are manufactured with dimensional accuracy and profile accuracy conforming to JIS B 1506 (Rollers for Roller Bearings). (**Table 2**)

Table 2 Needle roller tolerances

Unit: μm

Characteristics	Tolerance and allowable value
Tolerance for mean value of diameter D_w	0 \sim -10
Mutual deviation of diameter D_w	2
Roundness of diameter D_w , variation in diameter	1.0 ($L_w/D_w \leq 6$) 1.5 ($L_w/D_w > 6$)
Tolerance for length L_w	h13
Accuracy class	Class-2

The needle rollers are delivered contained in same package after the mutual deviation of diameter D_w was assorted to $2\mu\text{m}$ and less. Before being delivered, the needle rollers are identified by label colors such as red, dark blue, blue, etc. according to the respective dimensional tolerances.

Further, mixed use of needle rollers contained in packages of different label colors is prohibited.

Table 3 Discrimination of needle rollers

Label color	Dimensional tolerance range μm	Discrimination
Red	0 \sim - 2	Standard
Dark blue	-1 \sim - 3	
Blue	-2 \sim - 4	
Black	-3 \sim - 5	
White	-4 \sim - 6	
Gray	-5 \sim - 7	Semi-standard
Green	-6 \sim - 8	
Brown	-7 \sim - 9	
Yellow	-8 \sim -10	

Application of needle rollers

When composing a full-complement roller type needle roller bearing using standard needle rollers, shaft diameter (d), housing hole diameter (D), circumferential clearance (ΔC)

and radial clearance (Δr) must be determined respectively. These can be calculated as follows from needle roller diameter (D_w) and number of rollers (Z). (Refer to **Fig. 2**)

Determine the minimum value of circumferential clearance (ΔC) using **formula (1)**. And select radial clearance (Δr) according to applicable shaft diameter and operating conditions, in reference to **Table 5.1**, as the guideline, of 5.1 “**Bearing Radial Clearance**” (page A-30). In general, full-complement roller type bearing needs radial clearance larger than that in needle roller and cage assembly type roller bearing.

$$\Delta C = (0.005 \sim 0.020) \times Z \text{ mm (minimum value)} \quad (1)$$

Then, determine the minimum value of housing bore diameter (D) and the maximum value of shaft diameter (d) using the **formulas (2) and (3)**.

$$D = \left[\frac{1}{\sin\left(\frac{\pi}{Z}\right)} + 1 \right] \cdot D_w + \frac{\Delta C}{\pi} \text{ mm (minimum value)} \quad \dots\dots\dots(2)$$

$$d = D - 2D_w - \Delta r \text{ mm (maximum value)} \quad \dots\dots\dots(3)$$

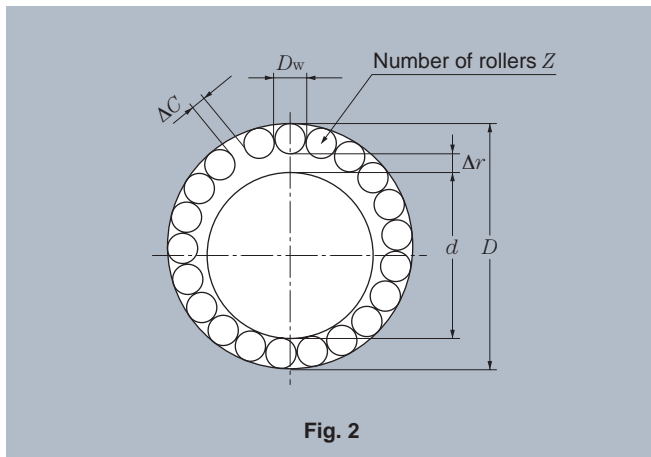

Fig. 2

The maximum value of housing bore diameter (D) required to retain needle rollers in a housing by a keystone can be determined from the minimum diameter value ($D_{w \text{ min}}$) of the roller and the number of rollers using **formula (4)**. The coefficient K to be used in that time is as shown in **Table 4**.

$$D = K \cdot D_{w \text{ min}} \text{ mm (max.)} \quad \dots\dots\dots(4)$$

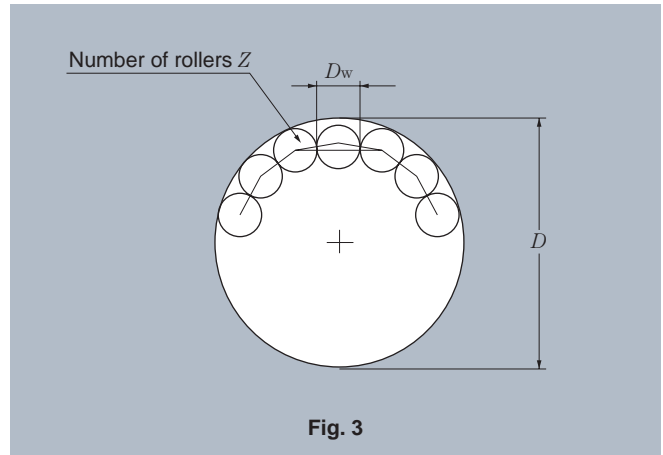
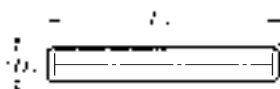

Fig. 3

Table 4 Coefficient K value

Z	K	Z	K
8	3.6763333	17	6.4536463
9	3.9709394	18	6.7689303
10	4.2727719	19	7.0846088
11	4.5789545	20	7.4006100
12	4.8879667	21	7.7168786
13	5.1989251	22	8.0333713
14	5.5112799	23	8.3500534
15	5.8246707	24	8.6668970
16	6.1388508	25	8.9838796

Type F
Type A

Type F

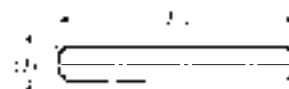

Type A

 D_w 1.5~4.5mm

Boundary dimensions mm		Bearing numbers		Mass	Boundary dimensions mm		Bearing numbers		Mass
D_w	L_w	flat type	disk type	kg per 1 000 pcs	D_w	L_w	flat type	disk type	kg per 1 000 pcs
1.5	5.8	F1.5× 5.8	A1.5× 5.8	0.080	3	23.8	F3 ×23.8	A3 ×23.8	1.34
	6.8	F1.5× 6.8	A1.5× 6.8	0.090		25.8	F3 ×25.8	A3 ×25.8	1.45
	7.8	F1.5× 7.8	A1.5× 7.8	0.104		27.8	F3 ×27.8	A3 ×27.8	1.56
	9.8	F1.5× 9.8	A1.5× 9.8	0.131	3.5	11.8	F3.5×11.8	A3.5×11.8	0.849
	11.8	F1.5×11.8	A1.5×11.8	0.159		13.8	F3.5×13.8	A3.5×13.8	1.00
	13.8	F1.5×13.8	A1.5×13.8	0.186		15.8	F3.5×15.8	A3.5×15.8	1.15
2	6.8	F2 × 6.8	A2 × 6.8	0.158		17.8	F3.5×17.8	A3.5×17.8	1.30
	7.8	F2 × 7.8	A2 × 7.8	0.183		19.8	F3.5×19.8	A3.5×19.8	1.45
	9.8	F2 × 9.8	A2 × 9.8	0.232		21.8	F3.5×21.8	A3.5×21.8	1.60
	11.8	F2 ×11.8	A2 ×11.8	0.281	23.8	F3.5×23.8	A3.5×23.8	1.75	
	13.8	F2 ×13.8	A2 ×13.8	0.330	25.8	F3.5×25.8	A3.5×25.8	1.90	
	15.8	F2 ×15.8	A2 ×15.8	0.379	29.8	F3.5×29.8	A3.5×29.8	2.20	
17.8	F2 ×17.8	A2 ×17.8	0.428	31.8	F3.5×31.8	A3.5×31.8	2.35		
19.8	F2 ×19.8	A2 ×19.8	0.477	34.8	F3.5×34.8	A3.5×34.8	2.58		
2.5	7.8	F2.5× 7.8	A2.5× 7.8	0.284	4	13.8	F4 ×13.8	A4 ×13.8	1.27
	9.8	F2.5× 9.8	A2.5× 9.8	0.351		15.8	F4 ×15.8	A4 ×15.8	1.50
	11.8	F2.5×11.8	A2.5×11.8	0.438		17.8	F4 ×17.8	A4 ×17.8	1.70
	13.8	F2.5×13.8	A2.5×13.8	0.514		19.8	F4 ×19.8	A4 ×19.8	1.89
	15.8	F2.5×15.8	A2.5×15.8	0.591		21.8	F4 ×21.8	A4 ×21.8	2.09
	17.8	F2.5×17.8	A2.5×17.8	0.668		23.8	F4 ×23.8	A4 ×23.8	2.26
	19.8	F2.5×19.8	A2.5×19.8	0.745		25.8	F4 ×25.8	A4 ×25.8	2.48
	21.8	F2.5×21.8	A2.5×21.8	0.821		27.8	F4 ×27.8	A4 ×27.8	2.68
23.8	F2.5×23.8	A2.5×23.8	0.898	29.8	F4 ×29.8	A4 ×29.8	2.87		
3	9.8	F3 × 9.8	A3 × 9.8	0.556	31.8	F4 ×31.8	A4 ×31.8	3.07	
	11.8	F3 ×11.8	A3 ×11.8	0.671	34.8	F4 ×34.8	A4 ×34.8	3.31	
	13.8	F3 ×13.8	A3 ×13.8	0.784	37.8	F4 ×37.8	A4 ×37.8	3.62	
	15.8	F3 ×15.8	A3 ×15.8	0.897	39.8	F4 ×39.8	A4 ×39.8	3.82	
	17.8	F3 ×17.8	A3 ×17.8	1.01	4.5	17.8	F4.5×17.8	A4.5×17.8	2.11
	19.8	F3 ×19.8	A3 ×19.8	1.12		19.8	F4.5×19.8	A4.5×19.8	2.36
	21.8	F3 ×21.8	A3 ×21.8	1.23		21.8	F4.5×21.8	A4.5×21.8	2.61

D_w 4.5~5mm

Boundary dimensions mm		Bearing numbers		Mass
D_w	L_w	flat type	disk type	kg per 1 000 pcs
4.5	23.8	F4.5×23.8	A4.5×23.8	2.86
	25.8	F4.5×25.8	A4.5×25.8	3.11
	29.8	F4.5×29.8	A4.5×29.8	3.62
	31.8	F4.5×31.8	A4.5×31.8	3.87
	34.8	F4.5×34.8	A4.5×34.8	4.25
	37.8	F4.5×37.8	A4.5×37.8	4.63
	39.8	F4.5×39.8	A4.5×39.8	4.88
	44.8	F4.5×44.8	A4.5×44.8	5.51
5	19.8	F5 ×19.8	A5 ×19.8	2.89
	21.8	F5 ×21.8	A5 ×21.8	3.20
	23.8	F5 ×23.8	A5 ×23.8	3.52
	25.8	F5 ×25.8	A5 ×25.8	3.82
	29.8	F5 ×29.8	A5 ×29.8	4.45
	31.8	F5 ×31.8	A5 ×31.8	4.74
	34.8	F5 ×34.8	A5 ×34.8	5.11
	37.8	F5 ×37.8	A5 ×37.8	5.55
	39.8	F5 ×39.8	A5 ×39.8	5.85
	49.8	F5 ×49.8	A5 ×49.8	7.33

Snap Rings

These snap rings are used exclusively for fixing or guiding a needle roller bearing ring or cage in axial direction. Furthermore, these snap rings have the profile identical to C-type concentric snap ring specified in JIS B 2806 and, in addition, snap rings with smaller section height (*b*) and also available in smaller dimension range are manufactured according to application of needle roller bearings. These snap rings are manufactured using hard steel wire rod and, after manufactured, chemical conversion treatment is applied to the surface thereof.

Types of snap ring

Two types of snap ring are available; one is **Type WR** designed for application to shaft and another is **Type BR** for application to bearing housing.

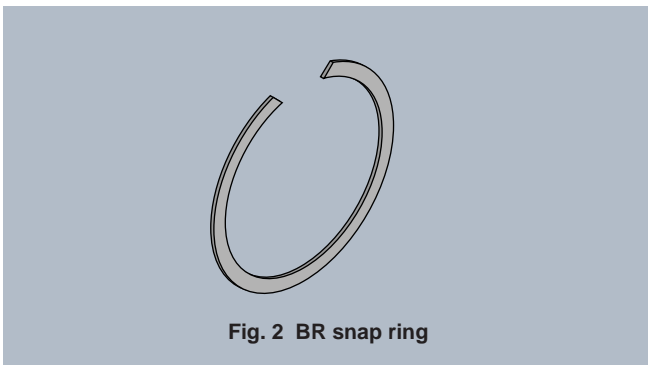
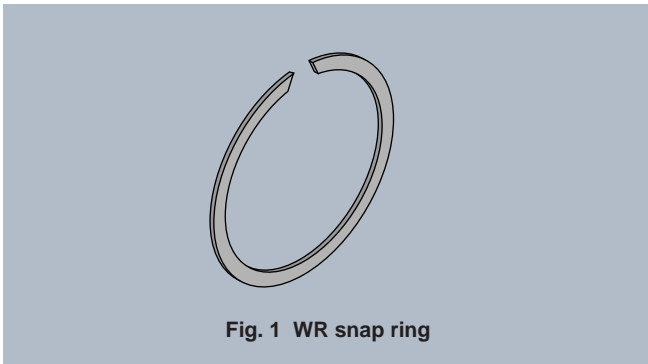

Composition of nominal number

The snap ring nominal number is composed of type code (**WR** or **BR**) and dimension code. The dimension code represents applicable shaft diameter in **Type WR** and applicable housing bore diameter in **Type BR**.

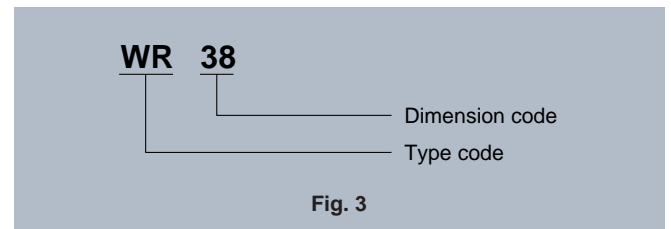

Allowable running speed

The allowable running speed for **Type WR** for shaft application is as described in applicable Dimensions Table. This means the running speed when snap ring begins to get loose with opening of its cut ends.

Mounting relation

It is recommended to insert a spacer between snap ring and cage for guiding the cage in axial direction. On occasion, snap ring is difficult to remove, but limited to a portion in which a pull-out

tool can not be inserted easily. In such a case, it is necessary to consider the use of general snap rings specified in JIS B 2804 (C-type snap rings) or B 2806 (C-type concentric snap rings).

Table 1 Cut section angle of snap ring (α)

Type	Nominal number	Cut section angle(α)
Type WR	WR4, WR5	40°
	Type WR6 up to	60°
Type BR	All nominal numbers	90°

For shaft

Type WR

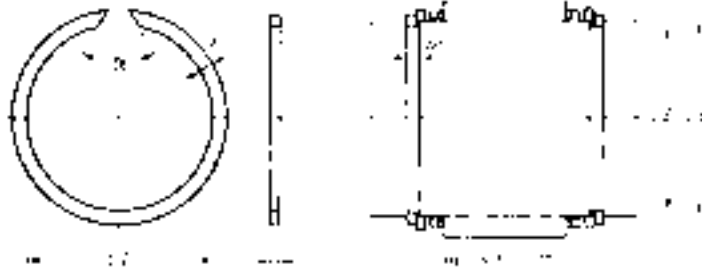

Bearing numbers	Boundary dimensions					Limiting speeds r/min
	d_1	d_3 max	b	s ± 0.06	d_2	
WR 4	4	3.7	0.8	0.5	3.8	275 000
WR 5	5	4.7	1	0.5	4.8	192 000
WR 6	6	5.6	1.1	0.7	5.7	141 000
WR 7	7	6.5	1.2	0.7	6.7 ⁰ _{-0.09}	134 000
WR 8	8	7.4	1.3	1	7.6	108 000
WR 9	9	8.4	1.3	1	8.6	80 000
WR10	10	9.4	1.3	1	9.6	68 000
WR11	11	10.2	1.3	1	10.5	64 500
WR12	12	11.2	1.3	1	11.5	53 000
WR13	13	12.2	1.3	1	12.5	49 600
WR14	14	13.1	1.5	1.2	13.5	45 900
WR15	15	14	1.75	1.2	14.4 ⁰ _{-0.11}	44 500
WR16	16	15	1.75	1.2	15.4	38 000
WR17	17	16	1.75	1.2	16.4	34 500
WR18	18	17	1.75	1.2	17.4	30 000
WR19	19	17.9	1.75	1.2	18.4	28 900
WR20	20	18.7	1.75	1.2	19.2	26 200
WR21	21	19.7	1.75	1.2	20.2	23 400
WR22	22	20.7	1.75	1.2	21.2	20 800
WR23	23	21.7	1.75	1.2	22.2	19 500
WR24	24	22.5	1.75	1.2	23 ⁰ _{-0.13}	18 100
WR25	25	23.5	1.75	1.2	24	16 400
WR26	26	24.5	1.75	1.2	25	14 800
WR28	28	26.5	2.3	1.5	27	15 400
WR29	29	27.5	2.3	1.5	28	14 400
WR30	30	28.5	2.3	1.5	29	13 200
WR32	32	30.2	2.3	1.5	30.8	13 300
WR35	35	33.2	2.3	1.5	33.8 ⁰ _{-0.16}	10 700

Bearing numbers	Boundary dimensions					Limiting speeds r/min
	d_1	d_3 max	b	s ± 0.06	d_2	
WR 37	37	35.2	2.3	1.5	35.8	9 200
WR 38	38	36.2	2.3	1.5	36.8	8 700
WR 40	40	37.8	2.3	1.5	38.5	8 100
WR 42	42	39.8	2.3	1.5	40.5	7 000
WR 43	43	40.8	2.3	1.5	41.5 ⁰ _{-0.16}	6 800
WR 45	45	42.8	2.3	1.5	43.5	5 800
WR 47	47	44.8	2.3	1.5	45.5	5 500
WR 48	48	45.8	2.3	1.5	46.5	5 300
WR 50	50	47.8	2.3	1.5	48.5	4 800
WR 52	52	49.8	2.3	1.5	50.5	4 300
WR 55	55	52.6	2.3	1.5	53.5	4 400
WR 58	58	55.6	2.3	1.5	56.5	3 900
WR 60	60	57.6	2.3	1.5	58.5	3 500
WR 61	61	58.6	2.3	1.5	59.5	3 300
WR 62	62	59.6	2.3	1.5	60.5	3 200
WR 63	63	60.6	2.3	1.5	61.5	3 100
WR 64	64	61.6	2.3	1.5	62.5 ⁰ _{-0.19}	2 900
WR 65	65	62.6	2.3	1.5	63.5	2 800
WR 68	68	65.4	2.8	2	66.2	2 900
WR 70	70	67.4	2.8	2	68.2	2 700
WR 72	72	69.4	2.8	2	70.2	2 600
WR 73	73	70.4	2.8	2	71.2	2 500
WR 75	75	72.4	2.8	2	73.2	2 300
WR 80	80	77.4	2.8	2	78.2	1 950
WR 85	85	82	3.4	2.5	83	2 300
WR 90	90	87	3.4	2.5	88	2 000
WR 95	95	92	3.4	2.5	93 ⁰ _{-0.22}	1 750
WR100	100	97	3.4	2.5	98	1 560

For shaft

Type WR

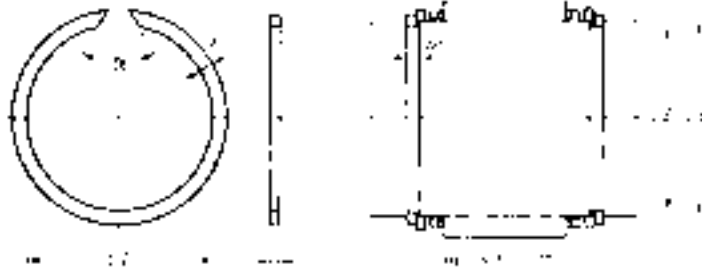

Bearing numbers	Boundary dimensions					Limiting speeds r/min
	d_1	d_3 max	b	s ± 0.06	d_2	
WR105	105	101.7	3.4	2.5	102.7	1 390
WR110	110	106.7	3.4	2.5	107.7	1 240
WR115	115	111.7	3.4	2.5	112.7	0 -0.22 1 100
WR120	120	116.7	3.4	2.5	117.7	1 000
WR125	125	121.7	3.4	2.5	122.7	920
WR130	130	126.7	3.4	2.5	127.7	830
WR135	135	131.6	4	2.5	132.4	830
WR140	140	136.6	4	2.5	137.4	760
WR145	145	141.6	4	2.5	142.4	690
WR150	150	146.6	4	2.5	147.4	640
WR155	155	151.6	4	2.5	152.4	0 -0.25 590
WR160	160	156.6	4	2.5	157.4	550
WR165	165	161.6	4	2.5	162.4	500
WR170	170	166.6	4	2.5	167.4	470
WR175	175	171.6	4	2.5	172.4	440
WR180	180	175.6	5	3	177	430
WR185	185	180.6	5	3	182	590
WR190	190	185.6	5	3	187	540
WR195	195	190.6	5	3	192	510
WR200	200	195.6	5	3	197	480
WR210	210	205.6	5	3	207	420
WR220	220	215.6	5	3	217	0 -0.29 380
WR225	225	220.6	5	3	222	360
WR230	230	225.6	5	3	227	350
WR240	240	235.6	5	3	237	310
WR250	250	245.6	5	3	247	270
WR260	260	253	7.5	4	255	430
WR265	265	258	7.5	4	260	0 -0.32 410

Bearing numbers	Boundary dimensions					Limiting speeds r/min
	d_1	d_3 max	b	s ± 0.06	d_2	
WR270	270	263	7.5	4	265	380
WR280	280	273	7.5	4	275	360
WR285	285	278	7.5	4	280	350
WR290	290	283	7.5	4	285	0 -0.32 340
WR300	300	293	7.5	4	295	300
WR305	305	298	7.5	4	300	290
WR310	310	303	7.5	4	305	280
WR320	320	313	7.5	4	315	260
WR330	330	323	7.5	4	325	240
WR340	340	333	7.5	4	335	220
WR350	350	343	7.5	4	345	210
WR360	360	353	7.5	4	355	0 -0.36 190
WR370	370	363	7.5	4	365	180
WR380	380	373	7.5	4	375	170
WR390	390	383	7.5	4	385	160
WR400	400	393	7.5	4	395	150

For housing

Type BR

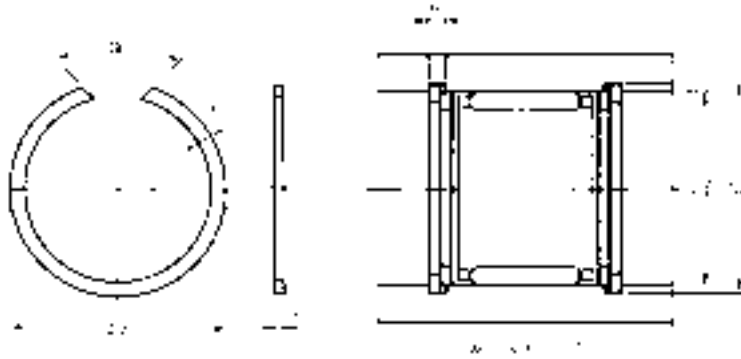

Bearing numbers	Boundary dimensions					
	d_1	d_3 min	b	s ± 0.06	d_2	
BR 7	7	7.5	1	0.8	7.3	$+0.09$ 0
BR 8	8	8.5	1	0.8	8.3	
BR 9	9	9.5	1.1	0.8	9.3	
BR10	10	10.6	1.2	0.8	10.4	
BR11	11	11.6	1.3	1	11.4	
BR12	12	12.7	1.3	1	12.4	
BR13	13	13.8	1.3	1	13.5	
BR14	14	14.8	1.3	1	14.5	
BR15	15	15.8	1.3	1	15.5	
BR16	16	16.8	1.6	1.2	16.5	
BR17	17	17.8	1.6	1.2	17.5	
BR18	18	18.9	1.75	1.2	18.5	
BR19	19	19.9	1.75	1.2	19.6	
BR20	20	21	1.75	1.2	20.6	$+0.13$ 0
BR21	21	22	1.75	1.2	21.6	
BR22	22	23	1.75	1.2	22.6	
BR23	23	24	1.75	1.2	23.6	
BR24	24	25.2	1.75	1.2	24.8	
BR25	25	26.2	1.75	1.2	25.8	$+0.16$ 0
BR26	26	27.2	1.75	1.2	26.8	
BR27	27	28.2	1.75	1.2	27.8	
BR28	28	29.2	1.75	1.2	28.8	
BR29	29	30.2	1.75	1.2	29.8	
BR30	30	31.4	2.3	1.5	31	
BR31	31	32.4	2.3	1.5	32	$+0.16$ 0
BR32	32	33.4	2.3	1.5	33	
BR33	33	34.4	2.3	1.5	34	
BR34	34	35.4	2.3	1.5	35	

Bearing numbers	Boundary dimensions					
	d_1	d_3 min	b	s ± 0.06	d_2	
BR35	35	36.4	2.3	1.5	36	
BR36	36	37.8	2.3	1.5	37.2	
BR37	37	38.8	2.3	1.5	38.2	
BR38	38	39.8	2.3	1.5	39.2	
BR39	39	40.8	2.3	1.5	40.2	
BR40	40	41.8	2.3	1.5	41.2	
BR41	41	42.8	2.3	1.5	42.2	
BR42	42	43.8	2.3	1.5	43.2	
BR43	43	44.8	2.3	1.5	44.2	
BR44	44	45.8	2.3	1.5	45.2	$+0.16$ 0
BR45	45	46.8	2.3	1.5	46.2	
BR46	46	47.8	2.3	1.5	47.2	
BR47	47	48.8	2.3	1.5	48.2	
BR48	48	49.8	2.3	1.5	49.2	
BR49	49	50.8	2.3	1.5	50.2	
BR50	50	51.8	2.3	1.5	51.2	
BR52	52	54.3	2.3	1.5	53.5	
BR53	53	55.3	2.3	1.5	54.5	
BR54	54	56.3	2.3	1.5	55.5	
BR55	55	57.3	2.3	1.5	56.5	
BR57	57	59.3	2.3	1.5	58.5	$+0.19$ 0
BR58	58	60.3	2.3	1.5	59.5	
BR60	60	62.3	2.3	1.5	61.5	
BR61	61	63.3	2.3	1.5	62.5	
BR62	62	64.3	2.3	1.5	63.5	
BR63	63	65.3	2.3	1.5	64.5	
BR64	64	66.3	2.3	1.5	65.5	
BR65	65	67.3	2.3	1.5	66.5	

For housing

Type BR

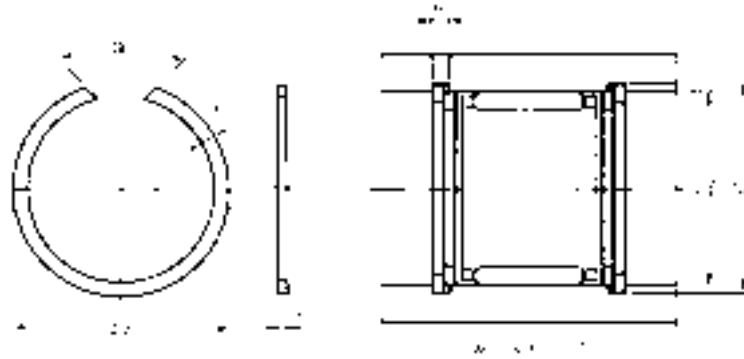

Bearing numbers	Boundary dimensions				
	d_1	d_3 min	b	s ± 0.06	d_2
BR 66	66	68.3	2.3	1.5	67.5
BR 68	68	70.3	2.3	1.5	69.5
BR 70	70	72.3	2.3	1.5	71.5
BR 72	72	74.6	2.8	2	73.8
BR 73	73	75.6	2.8	2	74.8
BR 74	74	76.6	2.8	2	75.8
BR 75	75	77.6	2.8	2	76.8
BR 76	76	78.6	2.8	2	77.8
BR 77	77	79.6	2.8	2	78.8
BR 78	78	80.6	2.8	2	79.8
BR 79	79	81.6	2.8	2	80.8
BR 81	81	83.6	2.8	2	82.8
BR 82	82	84.6	2.8	2	83.8
BR 83	83	85.6	2.8	2	84.8
BR 85	85	87.6	2.8	2	86.8
BR 86	86	88.6	2.8	2	87.8
BR 88	88	91	3.4	2.5	90
BR 90	90	93	3.4	2.5	92
BR 92	92	95	3.4	2.5	94
BR 93	93	96	3.4	2.5	95
BR 95	95	98	3.4	2.5	97
BR 97	97	100	3.4	2.5	99
BR 98	98	101	3.4	2.5	100
BR100	100	103	3.4	2.5	102
BR102	102	105.3	3.4	2.5	104.3
BR103	103	106.3	3.4	2.5	105.3
BR105	105	108.3	3.4	2.5	107.3
BR107	107	110.3	3.4	2.5	109.3

+0.19
0

+0.22
0

Bearing numbers	Boundary dimensions				
	d_1	d_3 min	b	s ± 0.06	d_2
BR108	108	111.3	3.4	2.5	110.3
BR110	110	113.3	3.4	2.5	112.3
BR112	112	115.3	3.4	2.5	114.3
BR113	113	116.3	3.4	2.5	115.3
BR115	115	118.3	3.4	2.5	117.3
BR117	117	120.3	3.4	2.5	119.3
BR118	118	121.3	3.4	2.5	120.3
BR120	120	123.3	3.4	2.5	122.3
BR123	123	126.3	3.4	2.5	125.3
BR125	125	128.3	3.4	2.5	127.3
BR127	127	130.3	3.4	2.5	129.3
BR130	130	133.3	3.4	2.5	132.3
BR133	133	136.3	3.4	2.5	135.3
BR135	135	138.3	3.4	2.5	137.3
BR137	137	140.3	3.4	2.5	139.3
BR140	140	143.6	4	2.5	142.6
BR143	143	146.6	4	2.5	145.6
BR150	150	153.6	4	2.5	152.6
BR153	153	156.6	4	2.5	155.6
BR160	160	163.6	4	2.5	162.6
BR163	163	166.6	4	2.5	165.6
BR165	165	168.6	4	2.5	167.6
BR170	170	173.6	4	2.5	172.6
BR173	173	176.6	4	2.5	175.6
BR175	175	178.6	4	2.5	177.6
BR180	180	183.6	4	2.5	182.6
BR183	183	186.6	4	2.5	185.6
BR190	190	194.5	5	3	193

+0.22
0

+0.25
0

+0.29
0

Bearing numbers	Boundary dimensions					
	d_1	d_3 min	mm		d_2	
			b	s ± 0.06		
BR195	195	199.5	5	3	198	
BR200	200	204.5	5	3	203	
BR205	205	209.5	5	3	208	
BR210	210	214.5	5	3	213	+0.29 0
BR215	215	219.5	5	3	218	
BR220	220	224.5	5	3	223	
BR225	225	229.5	5	3	228	
BR230	230	234.5	5	3	233	
BR240	240	244.5	5	3	243	
BR250	250	254.5	5	3	253	
BR260	260	267	7.5	4	265	+0.32 0
BR270	270	277	7.5	4	275	
BR280	280	287	7.5	4	285	
BR300	300	307	7.5	4	305	
BR320	320	327	7.5	4	325	
BR325	325	332	7.5	4	330	
BR350	350	357	7.5	4	355	
BR355	355	362	7.5	4	360	
BR360	360	367	7.5	4	365	+0.36 0
BR375	375	382	7.5	4	380	
BR380	380	387	7.5	4	385	
BR385	385	392	7.5	4	390	
BR395	395	402	7.5	4	400	
BR400	400	407	7.5	4	405	
BR415	415	422	7.5	4	420	
BR420	420	427	7.5	4	425	+0.40 0
BR440	440	447	7.5	4	445	

Seals

Seals

These are the special-purposed seals for needle roller bearings whose cross sectional height is designed so small as to match applicable needle roller bearings. These contact seals are made of synthetic rubber reinforced with steel plate, being then used in operating temperature range of -25 to +120°C and, under continuous running, at 100°C and less. Further, feel free to contact **NTN** for the use of these seals under special operating condition, e.g. operating temperature of over 120°C.

Types of seal

Two different seal types are available; one is **Type G** with one lip and another is **Type GD** with two lips. In addition to these two, sliding rubber seals (**LEG**, **LEGD**), wherein lubrication property was assigned to a rubber material fulfilling low torque under an non-lubrication environment, are also manufactured. Feel free to contact **NTN** for the detail of these seal types.

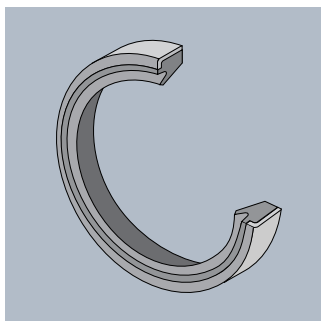

Fig. 1 Type G (LEG)

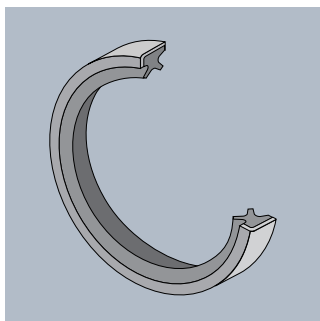

Fig. 2 Type GD (LEGD)

Where seal contact surface and lubricating condition are good, **Type G** with one lip can be used up to 10m/s maximum at peripheral speed and **Type GD** with two lips used up to 6m/s maximum.

This seal is intended to hold grease and to prevent dust invasion from outside. It has no function to hold lubrication oil, etc. unlike oil seal.

Composition of nominal number

Nominal seal number is composed of type code (G, GD) and dimension code (bore dia. × outer dia. × width).

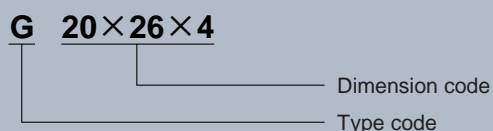

Fig. 3

Fitting relations

The seal contact surface must be finished by grinding, after hardened, to get its good sealing performance. In addition, harmful flaw and indent are not allowed to exist on the seal contact surface. Where the inner ring raceway surface is used as seal contact surface, a wide inner ring must be used.

When fitting a seal in a bearing, it is desirable to taper the shaft end face or the housing end face so as to protect the seal lip and outer surface from damaging, as illustrated in **Fig. 4**. Where shaft end is not tapered or chamfered (rounded), it is recommended to a fitting jig as illustrated in **Fig.5**. Regarding the seal to housing interference, a adequate interference can be got in the usual housing tolerance range of G7 to R7.

Furthermore, it is recommended to apply pre-coat of a lubricant to the seal lip before fitting seals G and GD, for better lubrication. Further, when fitting a seal and inserting it through a shaft, take good care to protect its lip from deforming.

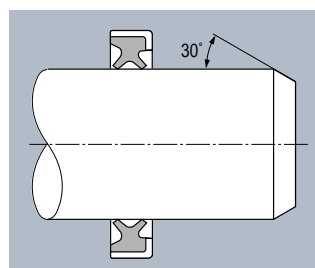

Fig. 4

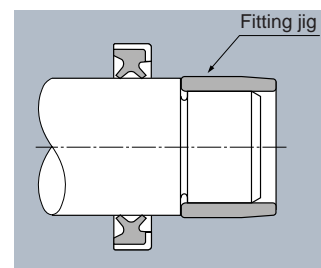

Fig. 5

Seal application examples

Figs.6 to 8 illustrate design examples using these seals.

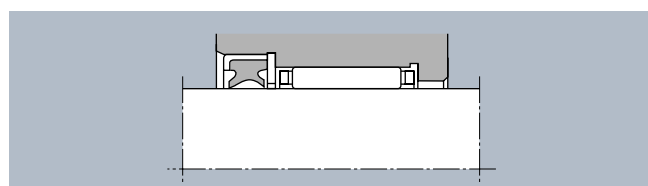

Fig. 6

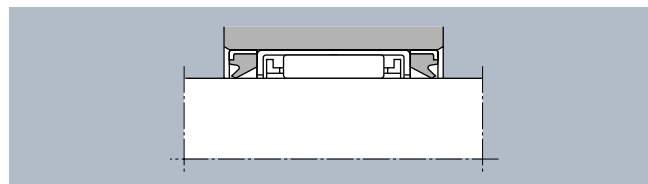

Fig. 7

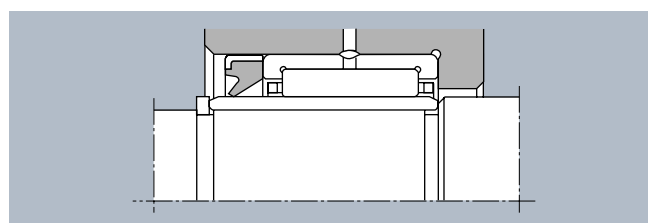
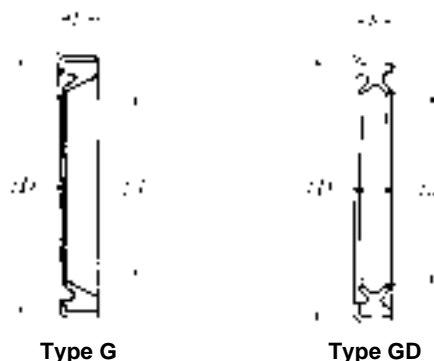

Fig. 8

Type G
Type GD



Bearing numbers		Boundary dimensions mm			Mass ×10 ⁻³ kg	
Type G	Type GD	d	D ¹⁾	b ^{+0.2} ₀	G	GD
G 4×8×2	—	4	8	2	0.18	—
G 5×9×2	—	5	9	^{+0.081} 2	0.19	—
G 5×10×2	—	5	10	^{+0.023} 2	0.22	—
G 6×10×2	—	6	10	2	0.21	—
G 6×12×2	—	6	12	2	0.38	—
G 7×11×2	—	7	11	2	0.25	—
G 7×14×2	—	7	14	2	0.52	—
G 8×12×3	—	8	12	3	0.41	—
G 8×15×3	—	8	15	3	0.74	—
G 9×13×3	—	9	13	^{+0.098} _{+0.028} 3	0.44	—
G 9×16×3	—	9	16	3	0.69	—
G10×14×3	—	10	14	3	0.50	—
G10×17×3	—	10	17	3	0.87	—
G12×16×3	—	12	16	3	0.56	—
G12×18×3	—	12	18	3	0.86	—
G12×19×3	—	12	19	3	0.94	—
G13×19×3	—	13	19	3	0.87	—
G14×20×3	GD14×20×3	14	20	3	0.96	0.99
G14×21×3	GD14×21×3	14	21	3	1.1	1.1
G14×22×3	GD14×22×3	14	22	3	1.3	1.2
G15×21×3	GD15×21×3	15	21	3	1.0	1.0
G15×23×3	GD15×23×3	15	23	^{+0.119} _{+0.035} 3	1.3	1.3
G16×22×3	GD16×22×3	16	22	3	1.3	1.1
G16×24×3	GD16×24×3	16	24	3	1.3	1.3
G16×25×3	GD16×25×3	16	25	3	1.6	1.6
G17×23×3	GD17×23×3	17	23	3	1.3	1.1
G17×25×3	GD17×25×3	17	25	3	1.5	1.4
G18×24×3	GD18×24×3	18	24	3	1.2	1.2

Bearing numbers		Boundary dimensions mm			Mass ×10 ⁻³ kg	
Type G	Type GD	d	D ¹⁾	b ^{+0.2} ₀	G	GD
G18×26×4	GD18×26×4	18	26	4	1.8	1.8
G19×27×4	GD19×27×4	19	27	4	2.0	1.9
G20×26×4	GD20×26×4	20	26	4	1.8	1.8
G20×28×4	GD20×28×4	20	28	^{+0.119} _{+0.035} 4	2.1	2.1
G21×29×4	GD21×29×4	21	29	4	2.2	2.1
G22×28×4	GD22×28×4	22	28	4	1.8	1.9
G22×30×4	GD22×30×4	22	30	4	2.2	2.3
G24×32×4	GD24×32×4	24	32	4	2.5	2.4
G25×32×4	GD25×32×4	25	32	4	2.3	2.2
G25×33×4	GD25×33×4	25	33	4	2.5	2.5
G25×35×4	GD25×35×4	25	35	4	2.6	2.6
G26×34×4	GD26×34×4	26	34	4	2.6	2.6
G28×35×4	GD28×35×4	28	35	4	2.4	2.5
G28×37×4	GD28×37×4	28	37	4	3.1	2.8
G29×37×4	GD29×37×4	29	37	4	2.7	2.7
G29×38×4	GD29×38×4	29	38	4	3.2	2.9
G30×37×4	GD30×37×4	30	37	^{+0.143} _{+0.043} 4	2.7	2.6
G30×40×4	GD30×40×4	30	40	4	3.6	3.3
G32×42×4	GD32×42×4	32	42	4	3.7	3.9
G32×45×4	GD32×45×4	32	45	4	5.1	5.2
G35×42×4	GD35×42×4	35	42	4	3.0	2.9
G35×45×4	GD35×45×4	35	45	4	4.1	3.6
G37×47×4	GD37×47×4	37	47	4	4.0	3.8
G38×48×4	GD38×48×4	38	48	4	4.4	4.0
G40×47×4	GD40×47×4	40	47	4	3.3	3.5
G40×50×4	GD40×50×4	40	50	4	4.6	4.0
G40×52×5	GD40×52×5	40	52	^{+0.173} 5	4.8	4.7
G42×52×4	GD42×52×4	42	52	^{+0.053} 4	4.7	4.2

Note 1) The outer diameter tolerance is the mean value of the measured values at two measuring points.

Type G
Type GD



Type G

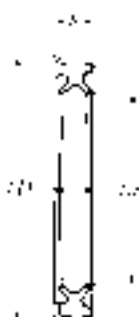

Type GD

Bearing numbers		Boundary dimensions mm			Mass ×10 ⁻³ kg	
Type G	Type GD	<i>d</i>	<i>D</i> ¹⁾	<i>b</i> _{+0.2 0}	G	GD
G43×53×4	GD43×53×4	43	53	4	4.8	4.3
G45×52×4	GD45×52×4	45	52	4	3.8	3.8
G45×55×4	GD45×55×4	45	55 ^{+0.173 +0.053}	4	5.2	5.5
G50×58×4	GD50×58×4	50	58	4	4.5	5.2
G50×62×5	GD50×62×5	50	62	5	10.4	10

Note 1) The outer diameter tolerance is the mean value of the measured values at two measuring points.

LINEAR BALL BEARINGS: Solid, Drawn Cup, Stroke, Linear Flat Roller, and Linear Roller Bearing Types

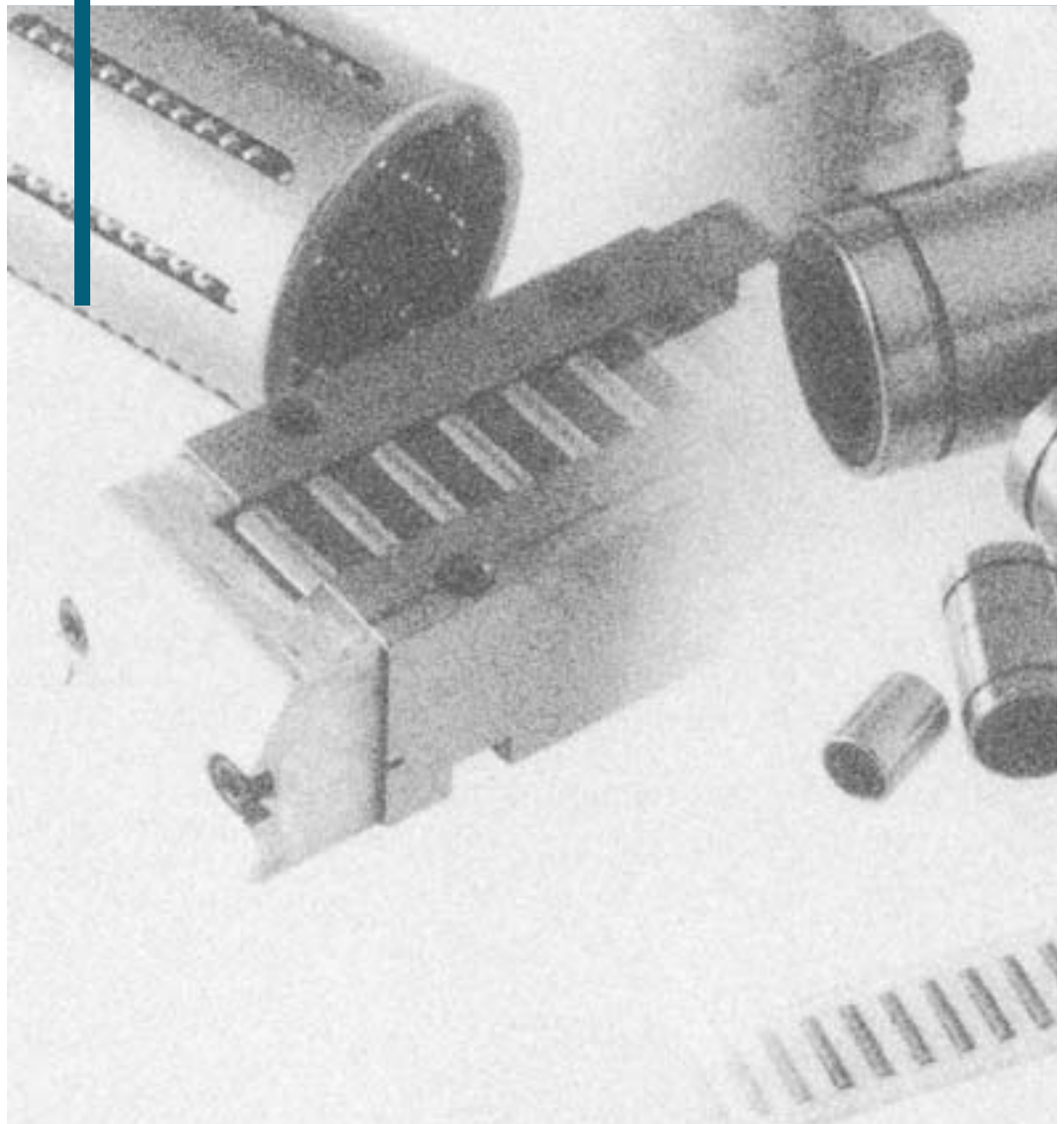

Linear Ball Bearings

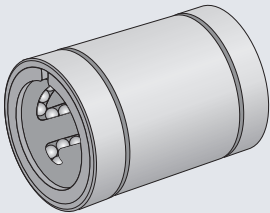
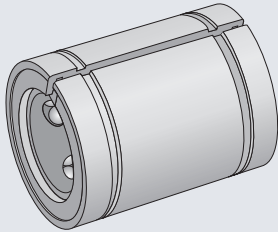
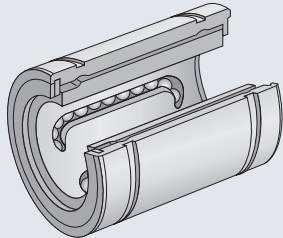
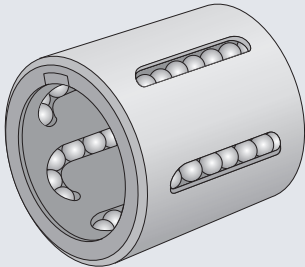
Type	Applied shaft diameter (mm)	Composition of nominal number
<p>KLM</p>  <p>This type composed of an outer ring, steel balls and a cage is a cylindrical bearing for the most universal applications, which ensures precise and smooth infinite linear motion due to its outer ring of high rigidity.</p>	<p>$\phi 3 \sim \phi 40$</p>	<p>KLM 06 L</p> <ul style="list-style-type: none"> — Tail code — Inscribed circle diameter — Type code
<p>KLM · · S</p>  <p>This type is composed of an outer ring, steel balls and a cage. And both of the outer ring and the cage have an axial slit, as illustrated, so as to enable to shrink the inscribed circle diameter of the cage by pressing the outer ring in radial direction from the housing and to thereby adjust radial clearance from shaft. Thus, this type also ensures precise and smooth infinite linear motion.</p>	<p>$\phi 16 \sim \phi 40$</p>	<p>KLM 30 S</p> <ul style="list-style-type: none"> — Tail code — Inscribed circle diameter — Type code
<p>KLM · · P</p>  <p>This type is composed of an outer ring, steel balls and a cage. And the outer ring and the cage are of arc sectional shape, from which one row of balls (equivalent to 50° to 60° degree spacing) is removed. Thus, the arc cross-sectional ring and cage with 50° to 60° degree opening allows the bearing assy to pass through a shaft support truss or a shaft support stand on midway of the shaft stroke. This type also ensures precise and smooth infinite linear motion, similarly to other types. The bearing radial clearance can be also adjusted.</p>	<p>$\phi 16 \sim \phi 40$</p>	<p>KLM 30 P LL</p> <ul style="list-style-type: none"> — Tail code — Tail code — Inscribed circle diameter — Type code
<p>KH</p>  <p>This type is composed of an outer ring, steel balls and a cage and the outer ring is cylindrical similarly to that of Type KLM and drawn from a steel plate by precision deep drawing, then enabling to design a compact bearing construction of low section and lightweight. This type also ensures precise and smooth infinite linear motion similarly to other types.</p>	<p>$\phi 6 \sim \phi 50$</p> <p>With seal $\phi 10 \sim \phi 50$</p>	<p>KH 20 30 LL</p> <ul style="list-style-type: none"> — Tail code — Width — Inscribed circle diameter — Type code

Components	Infinite motion	Finite motion	Rotating motion	Remarks
Inscribed circle diameter: $\phi 6$ L: Single-side seal	○	—	×	<p>The cages of the bearing types KLM, KLM, S, KLM,P and KH are all molded from polyamide resin and, therefore, these bearing types shall be used at allowable temperature 120°C and, under continuous running, at 100°C and less.</p> <p>Furthermore, the operating temperature shall be held within the range of -25 to 100°C to prevent deterioration of seal and grease.</p> <p>These bearing types can't rotate.</p>
Inscribed circle diameter: $\phi 6$ S: Clearance-adjustable type	○	—	×	
Inscribed circle diameter: $\phi 30$ P: Open type LL: Double-side seal	○	—	×	
Inscribed circle diameter: $\phi 20$ Width: 30 LL: Double-side seal	○	—	×	

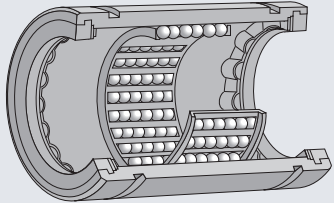
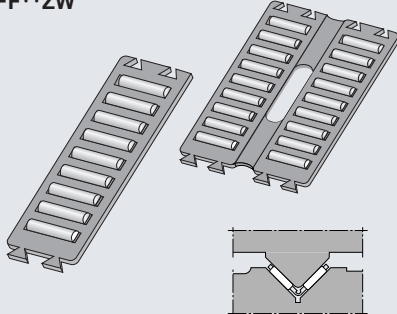
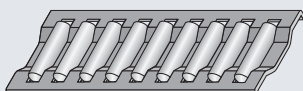
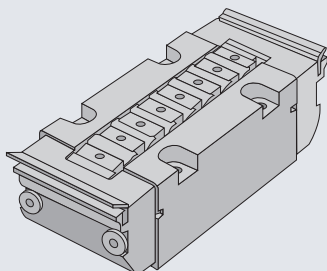
Type	Applied shaft diameter (mm)	Composition of nominal number
<p>KD</p> 	<p>This type composed of an outer ring, steel balls and a cage is a cylindrical bearing for the most universal applications, which ensures precise and smooth infinite linear motion due to its outer ring of high rigidity.</p>	<p>Shaft diameter $\phi 10 \sim \phi 80$</p> <p>KD 20 32 45 LL</p> <ul style="list-style-type: none"> — Tail code — Width — Outer diameter — Inscribed circle diameter — Type code
<p>FF FF··ZW</p> 	<p>This type composed of a cage and needle rollers ensures smooth reciprocating motion of less friction actor by being inserted between two planes in relative position. The cage made of polyamide resin is provided with grooved joint at its both ends so several cages can be jointed together into one unit.</p>	<p>Roller diameter $\phi 2 \sim \phi 3.5$</p> <p>FF 25 18 ZW</p> <ul style="list-style-type: none"> — Tail code — Width — Roller diameter $\times 10$ — Type code
<p>BF (RF)</p> 	<p>This type composed of a cage and needle rollers ensures smooth reciprocating motion of less friction factor by being inserted between two planes in relative position. Press-formed steel plate cage (BF) and polyamide resin cage (RF) are selectively available. However, in the case of this bearing type several bearings can't not be jointed together into one unit.</p>	<p>Roller diameter $\phi 3 \sim \phi 7$</p> <p>BF 30 20 / 1000</p> <ul style="list-style-type: none"> — Cage overall length — Width — Roller diameter $\times 10$ — Type code
<p>RLM</p> 	<p>This type is composed of a track frame, a separator and rollers. This type has the function enabling cylindrical rollers to circulate within the track frame and ensures infinite linear motion on a plane.</p>	<p>Section height 16~38</p> <p>RLM 26 × 86</p> <ul style="list-style-type: none"> — Bearing overall length — Section height — Type code

Components	Infinite motion	Finite motion	Rotating motion	Remarks
Inscribed circle diameter: $\phi 20$ Outer diameter: $\phi 32$ Width: 45	—	○	○	The operating temperature shall be held within the range of -25 to 100°C, to prevent deterioration of seal and grease.
Roller diameter: f2.5 Width: 18 ZW: Double-row type	○	—	×	Due to its resin cage, this bearing shall be used at allowable temperature 90°C and, under continuous running, at 80°C and less. The double-row type has an elastic joint on the cage center so double rows of flat rollers can be bent to any optional angle along the elastic joint by heating them in oil of 70 to 90°C. By cooling down the double-row rollers with the bent angle held unchanged for several seconds after having bent them to any optional angle, the bent shape of the double rows can be held unchanged so that the double-row rollers can be mounted on a V-shaped surface as illustrated.
Roller diameter: f3 Width: 20 Cage length: 1000	○	—	×	Where the resin cage RF is used, the bearing shall be used at allowable temperature 90°C and, under continuous running, at 80°C and less. The standard length of the bearing unit with BF cage is 1000 mm. The standard length of the bearing unit with RF cage is 705 mm. Two or more bearings of this type can't be jointed with each other, but it can be supplied at any desired length on request.
Section height: 26 Bearing overall length: 86	○	—	×	

Linear Ball Bearings, Solid and Drawn Cup Types

Four to nine rows of balls are configured equally in the outer ring (outer cylinder). The ball rows circulate in axial direction while being guided by the cage. Thus, these bearing types move infinitely on a shaft in axial direction. However, these bearing types can't rotate.

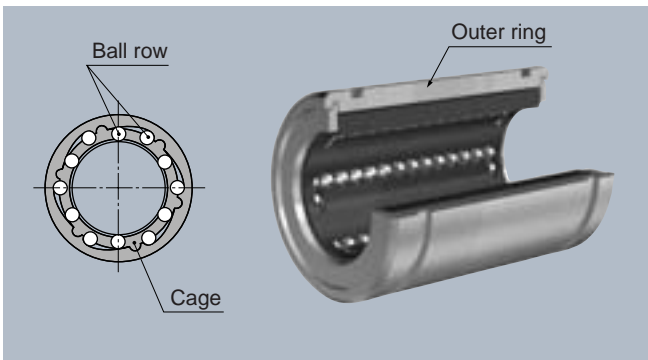

Fig. 1

Dimensional accuracy

The respective accuracy of the boundary dimensions, inscribed circle diameter (F_w), outer diameter (D), and width (C) of **Type KLM** (solid type bearing) are as described in applicable Dimensions Table. Same bearing with higher dimensional accuracy is offerable on special request. Feel free to contact **NTN** when such a bearing is needed.

For Type KH (drawn cup type), its outer ring is so thin-walled that it deforms inevitably to some extent in the manufacturing processes, particularly heat-treating process, but it is so designed as to be restored normally from such deformation and fulfill its specific function with the required accuracy by being press-fitted in a housing with the required dimensional accuracy.

Feel free to contact **NTN** for the method of measuring the dimensional accuracy.

Bearing fit

The use of a shaft or a housing with the dimensional tolerance shown in **Table 1** would ensure proper radial clearance. Where further small radial clearance is wanted or preload is applied, the radial clearance is adjusted using a split housing or otherwise bearing fit required for smaller clearance or preload is selected.

Table 1 Bearing fit

Type	Shaft	Housing
series KLM Solid type	g6 (g5)	H7 (H6)
series HK Drawn-cup type	h6 (j5)	H7 (H6) - steel series - K7 (K6) - light metal alloy series -

Note) The parenthesized data is applied to shaft/housing subjected to higher accuracy or of vertical construction.

Shaft and housing requirements

Any shaft /housing on/in which these bearing types are fitted must meet the requirements specified in **Table 2**.

Table 2 Shaft and housing requirements

Characteristics	Shaft	Housing
Roundness (max)	IT3	IT4
Cylindricity (max)	IT2	IT4
Surface roughness (max.)	0.4a	1.6a
Surface hardness	HRC58~64	—
Hardened layer depth (min)	0.4mm	—

How to mount

The housing for **Type KLM** (solid type) can't be fixed perfectly with interference only and, therefore, must be fixed in axial direction using a snap ring.

On the other hand, **Type KH** (drawn cup type) needs no axial fixing by a snap ring because it is press-fitted in a housing with interference. For press-fitting, press the outer ring at its stamped mark side (hardened side) using a mandrel illustrated in **Fig.2**.

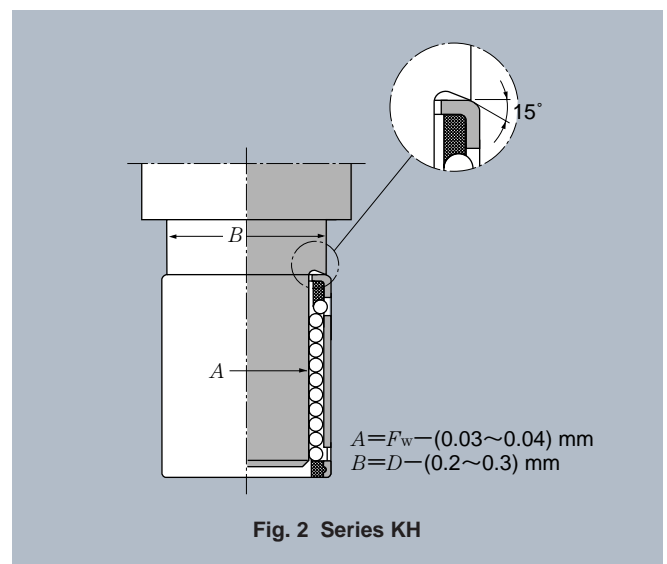

Fig. 2 Series KH

Accessories

Shafts, shaft support stands and housings exclusive for **NTN** linear ball bearings are also offerable. Feel free to contact **NTN** for the detailed information.

Type KLM Type KLM··LL
 Type KLM··S Type KLM··SLL
 Type KLM··P Type KLM··PLL



With seal

F_w 3~35mm

Boundary dimensions										Basic load ratings				Bearing numbers	Number of ball rows	Mass kg (approx.)
F_w	D	C	mm			g	h	θ	dynamic N	static N	dynamic kgf	static kgf				
			C_1	C_2	D_1				C_r	C_{or}	C_r	C_{or}				
3	$7^{0}_{-0.008}$	$10^{0}_{-0.010}$	$10^{0}_{-0.120}$	—	—	—	—	—	51	40	5	4	KLM03	4	0.002	
4	$8^{0}_{-0.008}$	$12^{0}_{-0.010}$	$12^{0}_{-0.120}$	—	—	—	—	—	71	52	7	5.5	KLM04	4	0.003	
5	$10^{0}_{-0.009}$	$15^{0}_{-0.010}$	$15^{0}_{-0.120}$	—	—	—	—	—	118	90	12	9	KLM05	4	0.005	
6	$12^{0}_{-0.009}$	$19^{0}_{-0.010}$	$19^{0}_{-0.120}$	13.3	1.1	11.5	—	—	130	107	13	11	KLM06	4	0.009	
8	$15^{0}_{-0.009}$	$17^{0}_{-0.010}$	$17^{0}_{-0.120}$	11.3	1.1	14.3	—	—	116	94	12	9.5	KLM08	4	0.012	
	$15^{0}_{-0.009}$	$24^{0}_{-0.010}$	$24^{0}_{-0.120}$	17.3	1.1	14.3	—	—	234	187	24	19	KLM08-1	4	0.017	
10	$19^{0}_{-0.009}$	$29^{0}_{-0.012}$	$29^{0}_{-0.120}$	21.7	1.3	18	—	—	435	297	45	30	KLM10	4	0.028	
12	$22^{0}_{-0.009}$	$32^{0}_{-0.012}$	$32^{0}_{-0.120}$	22.7	1.3	21	—	—	480	380	49	39	KLM12	5	0.042	
13	$23^{0}_{-0.009}$	$32^{0}_{-0.012}$	$32^{0}_{-0.120}$	22.7	1.3	22	—	—	540	455	55	47	KLM13	5	0.045	
16	28	37	26.5	1.6	27	—	—	—	875	670	89	68	KLM16	5	0.075	
	$28^{0}_{-0.009}$	$37^{0}_{-0.012}$	$37^{0}_{-0.120}$	26.5	1.6	27	0.6	—	875	670	89	68	KLM16S	5	0.075	
	28	37	26.5	1.6	27	—	8.2	60°	875	670	89	68	KLM16P	4	0.062	
20	32	42	30.3	1.6	30.5	—	—	—	1 190	985	121	100	KLM20	6	0.10	
	$32^{0}_{-0.010}$	$42^{0}_{-0.014}$	$42^{0}_{-0.120}$	30.3	1.6	30.5	0.6	—	1 190	985	121	100	KLM20S	6	0.10	
	32	42	30.3	1.6	30.5	—	8.6	50°	1 190	985	121	100	KLM20P	5	0.085	
25	40	59	40.7	1.85	38	—	—	—	2 640	2 340	269	239	KLM25	6	0.22	
	$40^{0}_{-0.010}$	$59^{0}_{-0.014}$	$59^{0}_{-0.120}$	40.7	1.85	38	0.6	—	2 640	2 340	269	239	KLM25S	6	0.22	
	40	59	40.7	1.85	38	—	10.8	50°	2 640	2 340	269	239	KLM25P	5	0.19	
30	45	64	44.2	1.85	43	—	—	—	2 540	2 360	259	241	KLM30	6	0.26	
	$45^{0}_{-0.010}$	$64^{0}_{-0.014}$	$64^{0}_{-0.120}$	44.2	1.85	43	0.6	—	2 540	2 360	259	241	KLM30S	6	0.26	
	45	64	44.2	1.85	43	—	13.0	50°	2 540	2 360	259	241	KLM30P	5	0.22	
35	52	70	49.2	2.2	49	—	—	—	3 400	2 970	345	305	KLM35	6	0.40	
	$52^{0}_{-0.012}$	$70^{0}_{-0.017}$	$70^{0}_{-0.120}$	49.2	2.2	49	1.2	—	3 400	2 970	345	305	KLM35S	6	0.40	
	52	70	49.2	2.2	49	—	15.1	50°	3 400	2 970	345	305	KLM35P	5	0.34	

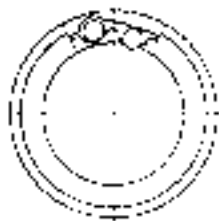

Type KLM
(Standard type)



Type KLM·S
(Clearance-adjustable type)



Type KLM·P
(Open type)

F_w 40mm

F_w	Boundary dimensions								Basic load ratings				Bearing numbers	Number of ball rows	Mass kg (approx.)
	D	C	mm		D_1	g	h	θ	dynamic	static	dynamic	static			
			C_1	C_2					N	N	kgf	kgf			
			± 0.300						C_r	C_{or}	C_r	C_{or}			
40 _{-0.012} ⁰	60 _{-0.017} ⁰	80 _{-0.120} ⁰	60.3	2.1	57	—	—	—	3 950	3 750	400	385	KLM40	6	0.62
	60 _{-0.017} ⁰	80 _{-0.120} ⁰	60.3	2.1	57	1.2	—	—	3 950	3 750	400	385	KLM40S	6	0.62
	60 _{-0.017} ⁰	80 _{-0.120} ⁰	60.3	2.1	57	—	17.2	50°	3 950	3 750	400	385	KLM40P	5	0.53

Type KH
Type KH··LL

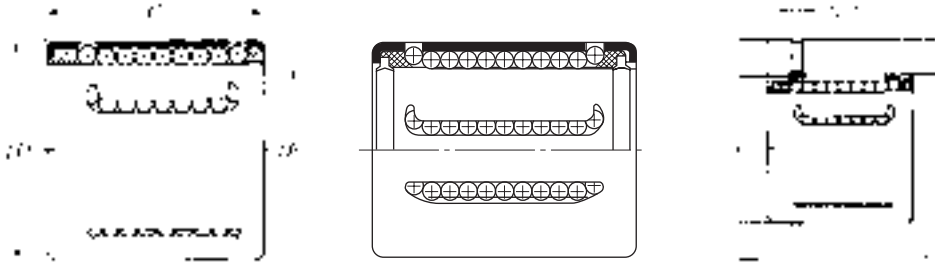

With seal

F_w 6~50mm

F_w	Boundary dimensions			Bearing numbers	Basic load ratings				Number of ball rows	Mass kg (approx.)
	mm				dynamic	static	dynamic	static		
	D	C	α^1		C_r	C_{or}	C_r	C_{or}		
6	12	22	4	KH0622 ²⁾	380	225	39	23	4	0.007
8	15	24	5	KH0824 ²⁾	420	255	43	26	4	0.012
10	17	26	5	KH1026 ²⁾	480	325	49	33	4	0.015
12	19	28	6	KH1228	605	495	62	51	5	0.018
	19	28	6	KH1228LL	605	495	62	51	5	0.018
14	21	28	6	KH1428	600	505	61	51	5	0.021
16	24	30	7	KH1630	775	600	79	61	5	0.027
	24	30	7	KH1630LL	775	600	79	61	5	0.027
20	28	30	7	KH2030	1 050	880	107	90	6	0.033
	28	30	7	KH2030LL	1 050	880	107	90	6	0.033
25	35	40	8	KH2540	1 930	1 560	197	159	6	0.066
	35	40	8	KH2540LL	1 930	1 560	197	159	6	0.066
30	40	50	8	KH3050	2 700	2 450	275	250	7	0.095
	40	50	8	KH3050LL	2 700	2 450	275	250	7	0.095
40	52	60	9	KH4060	4 250	4 000	435	410	8	0.18
50	62	70	9	KH5070	5 300	5 700	540	580	9	0.24

Note 1) Showing α -value from the side face with stamped mark thereon.
2) Imported product from INA, Germany.

Linear Ball Bearings, Stroke Type

The bearing cage with multiple ball rows (several balls per row) configured circumferentially therein can move within the outer ring in both circumferential and axial directions. Thus, this bearing type can rotate and reciprocate (but at a limited stroke) on a shaft.

Bearing construction

Maximum available length of the reciprocal stroke is two times as long as the stroke at which the cage can reciprocate within the outer ring. The outer ring is provided at its both ends with a snap ring acting as a stopper and a wave spring is provided between the snap ring and the cage to damp a shock acting on the cage as well as to prevent wear of the cage.

In addition to the standard type, a special type with synthetic rubber seal (Tail code: LL) on the both ends of its outer ring is also available.

Dimensional accuracy of Bearing

Table 1 the bearing tolerance.

Table 1 Dimensional accuracy

Characteristics	Dimensional tolerance
Ball inscribed circle diameter (F_w)	F6
Outer ring outer diameter (D)	h5

Bearing fit and radial clearance

Any linear ball bearings must be used with radial clearance as less as possible. Particularly where linear ball bearing is applied to a vertical shaft or high accuracy is required, it is desirable to select and combine appropriate bearing and shaft for securing radial clearance in the range of 0 to $-10 \mu\text{m}$ (by preloading).

Table 2 shows the bearing fits on shaft and in housing.

Table 2 Bearing fits

Operating conditions	Shaft	Housing
Usual operating conditions	k5 (m5)	H6 (H7)
Vertical shaft and high accuracy applications	n5 (p5) ^①	J6 (J7)

① Selective fit

Shaft and housing requirements

Table 3 specifies the requirements for shaft and housing which of the outer surfaces are used as the direct raceway.

Table 3 Shaft and housing requirements

Characteristics	Shaft	Housing
Roundness (max)	IT2	IT4
Cylindricity (max)	IT2	IT4
Surface roughness (max)	0.2a	1.6a
Surface hardness	HRC58~64	—
Hardened layer depth (min)	0.4mm	—

How to mount

This bearing type can't be fixed perfectly to a housing with interference only and, therefore, it is fixed in axial direction using a snap ring. (Refer to Fig. 1)

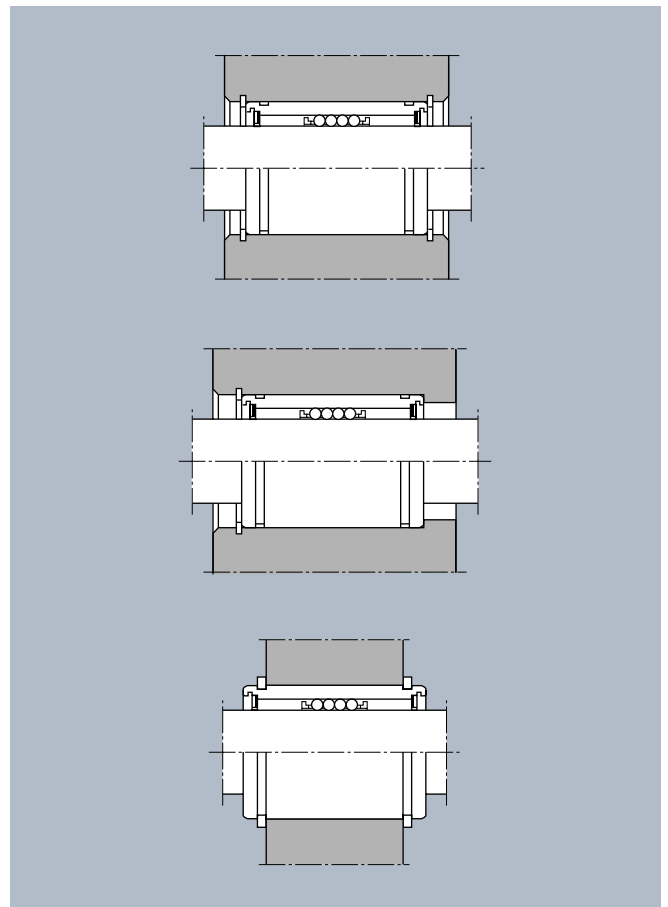

Fig. 1 Axial fixing of bearing

For adjusting the cage so it locates at the outer ring center after a shaft was mounted, push the cage in the arrow direction in **Fig. 2** by inserting the shaft into the outer ring that was press-fitted in the housing. (**Fig. 2**)

In this condition, insert slowly the shaft up to the center point of the reciprocating stroke and, thereafter, further push-in the shaft by 1/2 of the stroke. (**Fig. 3**) Then, return the shaft by 1/2 of the stroke to thereby locate the cage at the outer ring center and the shaft at the center point of the reciprocating stroke. (**Fig. 4**)

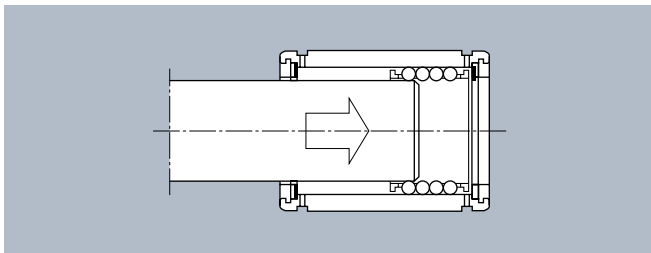

Fig. 2

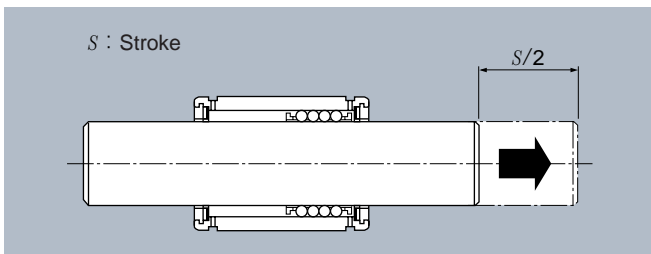

Fig. 3

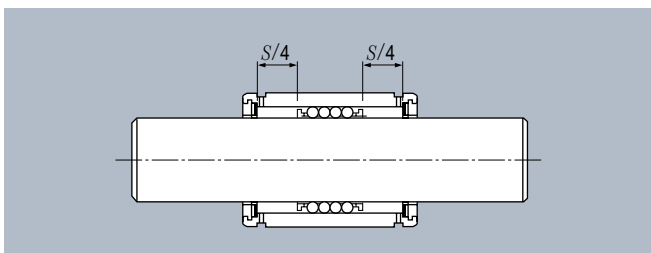
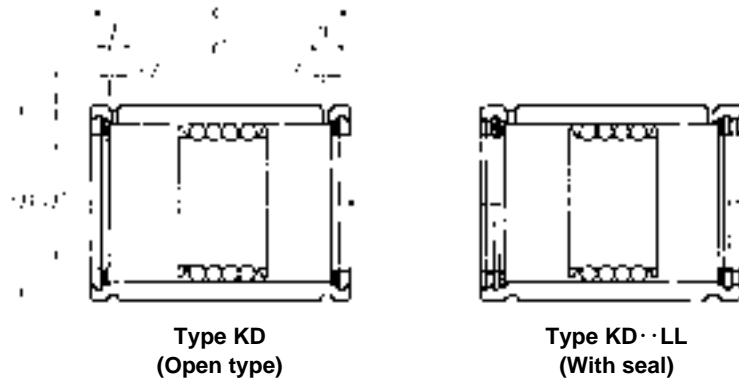

Fig. 4

The outer ring must be press-fitted so its grease feed hole locates at load non-acting side.
 Where moment load acts on a bearing due to use of a vertical shaft, the load could act on the grease feed hole. Caution it.

Type KD
Type KD··LL



F_w 10~80mm

F_w F6	D h5	$C^{(1)}$	Boundary dimensions mm								Bearing numbers		Basic load ratings				Mass (approx.) kg	
			T	t	d_1	Type KD C_1	Type KD Max. stroke	Type KD··LL C_1	Type KD··LL Max. stroke	Type KD	Type KD··LL	dynamic N	static	dynamic kgf	static	Type KD	Type KD··LL	
10	19	30	1.7	0.4	1.5	22.7	27	15.5	19	KD101930	KD101930LL	725	535	74	55	0.028	0.030	
12	23	32	1.7	0.4	1.5	24.5	30	17.1	22	KD122332	KD122332LL	925	725	94	74	0.052	0.055	
16	28	37	1.7	0.5	1.5	29.1	33	21.1	26	KD162837	KD162837LL	1 490	1 070	152	110	0.073	0.078	
20	32	45	2.2	0.5	2	35.8	55	26.8	46	KD203245	KD203245LL	1 680	1 230	171	125	0.100	0.105	
25	37	45	2.2	0.6	2	35.8	55	26.8	46	KD253745	KD253745LL	1 890	1 410	193	144	0.115	0.120	
30	45	65	2.7	0.7	2.5	53.5	81	45.1	73	KD304565	KD304565LL	3 850	3 100	390	315	0.265	0.265	
35	52	70	2.7	0.7	2.5	58.5	90	50.1	79	KD355270	KD355270LL	4 200	3 500	430	355	0.405	0.405	
40	60	80	2.7	0.7	2.5	68.3	103	59.9	93	KD406080	KD406080LL	5 900	4 750	600	485	0.635	0.635	
45	65	80	2.7	0.7	2.5	68.3	103	59.9	93	KD456580	KD456580LL	6 450	5 300	655	540	0.675	0.680	
50	72	100	3.2	1	3	86.4	136	77.4	125	KD5072100	KD5072100LL	8 500	6 850	870	695	1.00	1.02	
55	80	100	3.2	1	3	86.4	136	77.4	125	KD5580100	KD5580100LL	9 250	7 550	945	770	1.34	1.36	
60	85	100	3.2	1	3	86.4	136	77.4	122	KD6085100	KD6085100LL	9 900	8 250	1 010	845	1.41	1.43	
70	95	100	3.2	1	3	86.4	136	77.4	122	KD7095100	KD7095100LL	10 600	9 000	1 090	920	1.61	1.63	
80	110	100	3.2	1.2	3	86	129	77	116	KD80110100	KD80110100LL	13 300	10 900	1 360	1 110	2.37	2.40	

Note 1) The tolerance for dimension-C is 0, -0.120 mm against $F_w \leq 50$ mm and 0, -0.150 mm against $F_w > 50$ mm.

Linear Flat Rollers

Linear Flat Rollers

This bearing type composed of a needle roller and flat cage assembly (needle rollers are configured in the flat cage) ensures smooth reciprocating motion with less friction coefficient.

Types

For **Type FF**, the polyamide resin cage has a dovetail joint groove on its both ends so that several cages can be jointed together into one unit.

For **Type FF·ZW**, two rows of needle rollers are configured in the cage and the cage has an elastic joint on its center so as to enable to bend two rows of flat rollers to any optional angle at the elastic joint by heating them in oil of 70 to 90°C. The two roller rows bent to any optional angle can hold the bent shape unchanged, even under normal operating temperature, by being cooled down for several seconds, with the bending angle held unchanged.

For **Type BF**, the cage is press-formed from steel plate and the standard length of the bearing unit is 1000 mm.

For **Type RF**, the cage is of polyamide resin and the standard length of the bearing unit is 705 mm. The both are unavailable for cage to cage inter-jointing, but a bearing unit of any desired length is offerable upon request. Feel free to contact **NTN** for the detailed information.

Needle roller tolerance

The needle rollers contained in the flat roller cage are manufactured within the dimensional tolerance range of 0 to -2 mm against the nominal diameter (D_w).

Raceway surface requirements

Table 1 shows the requirements for raceway surface applied to the linear flat roller bearings.

Table 1 Raceway surface requirements

Characteristics	Tolerance
Surface roughness (max)	0.2a
Surface hardness ①	HRC58~64
Effective hardened layer depth (min)	0.4mm
Mounting accuracy (max) ②	0.1 mm per 1000 mm

① Where raceway surface hardening not allowed, a quenched spring plate may be used.

② Mounting accuracy is expressed with an inclination value in **Fig. 1**.

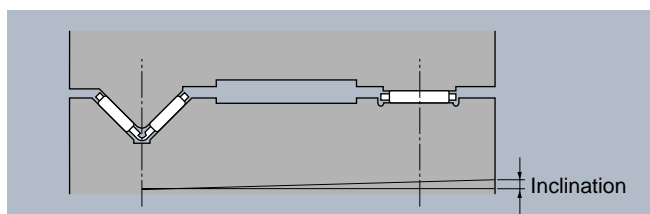

Fig. 1

How to mount

Theoretically the linear flat roller bearing moves by 1/2 of table moving stroke in same direction as the table moving direction. The relationship of bed length (L) - stroke (S) - cage length (L_1) can be expressed in **formula (1)**. (**Fig. 2**)

$$L = S/2 + L_1 \dots\dots\dots(1)$$

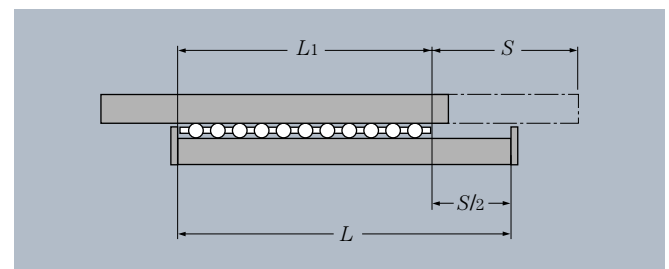

Fig. 2

The linear flat roller bearing results in moving deviation due to profile deviation of raceway surface, uneven load or vibration. Therefore, the table or the bed must be equipped with a stopper at its end portion to prevent over-run of the flat roller bearing. (**Fig. 5**)

Figs. 3 and 4 illustrate application examples of the linear flat roller bearing unit.

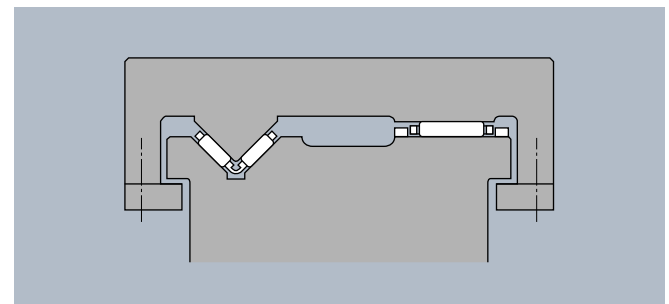

Fig. 3 General application

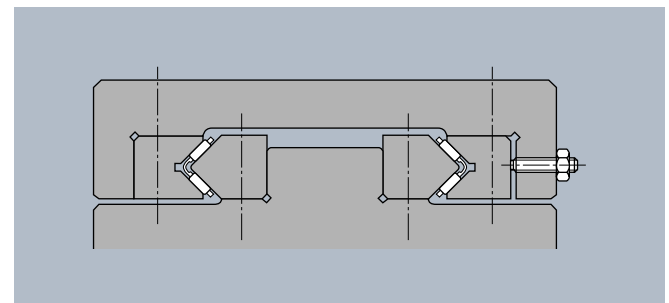

Fig. 4 When overhung load acts on

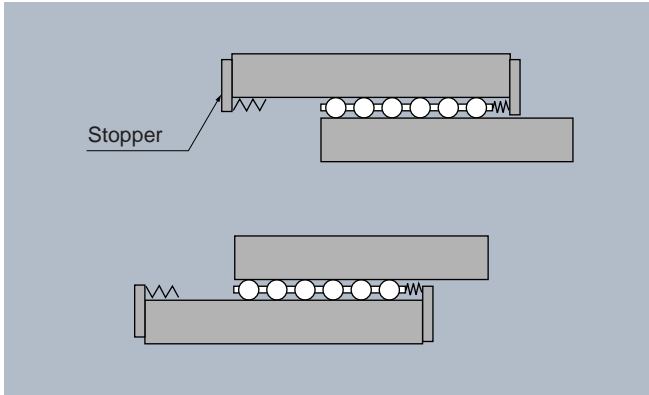
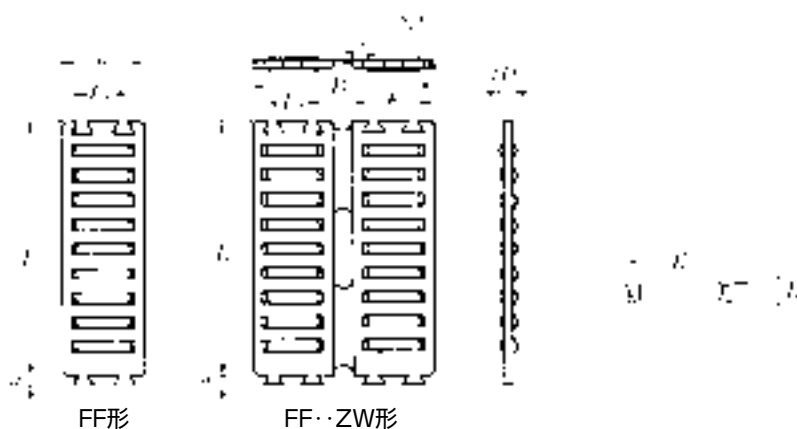

Fig. 5

Type FF
Type FF··ZW



D_w 2~3.5mm

Boundary dimensions						Basic load ratings				Bearing numbers	Number of rolls	Abutment dimensions		Mass kg (approx.)
mm						dynamic	static	dynamic	static			mm		
$D_w^{1)}$	b	B	L	L_w	a	C_r	C_{or}	C_r	C_{or}			E	H	
2	10	—	32	6.8	2	8 500	19 700	865	2 010	FF2010	7	10.3 $^{+0.1}_0$	1.7 $^0_{-0.2}$	0.0020
2	10	25	32	6.8	2	15 500	39 500	1 580	4 000	FF2025ZW	14	25.3 $^{+0.1}_0$	1.7 $^0_{-0.2}$	0.0043
2.5	15	—	45	9.8	2.4	17 100	41 400	1 740	4 200	FF2515	8	15.3 $^{+0.1}_0$	2.2 $^0_{-0.2}$	0.0038
2.5	15	35	45	9.8	2.4	29 300	82 500	2 980	8 450	FF2535ZW	16	35.3 $^{+0.1}_0$	2.2 $^0_{-0.2}$	0.0082
3	20	—	60	13.8	3	31 000	79 500	3 150	8 100	FF3020	9	20.4 $^{+0.1}_0$	2.7 $^0_{-0.2}$	0.0089
3	20	45	60	13.8	3	53 500	145 000	5 450	14 800	FF3045ZW	18	45.4 $^{+0.1}_0$	2.7 $^0_{-0.2}$	0.019
3.5	25	—	75	17.8	3.2	50 000	132 000	5 100	13 500	FF3525	10	25.4 $^{+0.1}_0$	3.2 $^0_{-0.2}$	0.017
3.5	25	55	75	17.8	3.2	86 000	265 000	8 800	27 000	FF3555ZW	20	55.4 $^{+0.1}_0$	3.2 $^0_{-0.2}$	0.035

Note 1) The dimensional tolerance for needle roller diameter D_w is 0 to $-2 \mu\text{m}$.

Type BF

Type RF

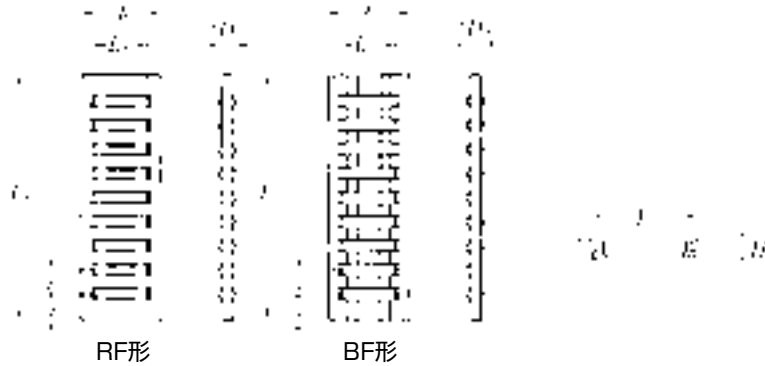

D_w 3~7mm

Boundary dimensions						Basic load ratings ³⁾				Bearing numbers	Abutment dimensions		Mass ⁴⁾ kg (approx.)
mm						dynamic	static	dynamic	static		mm		
$D_w^{1)}$	b	$L_1^{2)}$	L_w	l	a	C_r	C_{0r}	C_r	C_{0r}		E	H	
3	20	705	13.8	6	4.5	34 000	88 500	3 450	9 000	RF3020/705	20.4 $\begin{smallmatrix} +0.1 \\ 0 \end{smallmatrix}$	2.7 $\begin{smallmatrix} 0 \\ -0.2 \end{smallmatrix}$	0.015
3	20	1 000	15.8	6	5	38 000	102 000	3 850	10 400	BF3020/1000	20.4 $\begin{smallmatrix} +0.1 \\ 0 \end{smallmatrix}$	2.7 $\begin{smallmatrix} 0 \\ -0.2 \end{smallmatrix}$	0.037
5	23	1 000	19.8	8	8	87 000	211 000	8 850	21 500	BF5023/1000	23.4 $\begin{smallmatrix} +0.1 \\ 0 \end{smallmatrix}$	4.7 $\begin{smallmatrix} 0 \\ -0.2 \end{smallmatrix}$	0.054
5	32	1 000	27.8	8	8	114 000	299 000	11 600	30 500	BF5032/1000	32.4 $\begin{smallmatrix} +0.1 \\ 0 \end{smallmatrix}$	4.7 $\begin{smallmatrix} 0 \\ -0.2 \end{smallmatrix}$	0.073
7	28	1 000	24	11	10.5	155 000	355 000	15 800	36 000	BF7028/1000	28.5 $\begin{smallmatrix} +0.1 \\ 0 \end{smallmatrix}$	6.7 $\begin{smallmatrix} 0 \\ -0.2 \end{smallmatrix}$	0.091
7	35	1 000	30	11	10.5	185 000	445 000	18 900	45 500	BF7035/1000	35.5 $\begin{smallmatrix} +0.1 \\ 0 \end{smallmatrix}$	6.7 $\begin{smallmatrix} 0 \\ -0.2 \end{smallmatrix}$	0.110

Note 1) The dimensional tolerance for needle roller diameter D_w is 0 to $-2 \mu\text{m}$.

2) The standard length L_1 of the cage shall be 1000 mm for Type BF and 705 mm for Type RF.

Where special cage length is required, the nominal bearing number is followed by the numerical length value as exemplified below.

Ex. Where $L_1 = 500$ mm is required for **BF3020**, **BF302/500**

3) The listed basic load ratings are subject to use of 10 flat rollers. Calculate the basic load ratings for any optional cage length L_1 by the following formula.

$$C = f_1^{7/9} \cdot C_r$$

$$C_0 = f_1 \cdot C_{0r}$$

$$\text{Herein, } f_1 = 0.1 (L_1 + l - 2a) / l$$

4) The listed weights are subject to $L_1 = 100$ mm.

Remarks: For **Type BF**

1. On occasion, the length of an ordered unit could be shorter by l dimension shown in each Dimensions Table because the roller and cage assy is cut at the minimum unit of each pocket so as to match the required length.
2. Where this bearing unit is used frequently at various lengths, it is more economical to cut the standard bearing of 1000 mm length to each desired length at your side.

Linear Roller Bearings

This roller bearing with cylindrical rollers having the function capable of circulating within the raceway block ensures smooth infinite linear motion on a flat surface. The cylindrical rollers are retained and guided by the cage and the ribs of the raceway block.

The cage is of such a construction as not allow adjacent rollers to contact with one another. Hence, the friction coefficient is low.

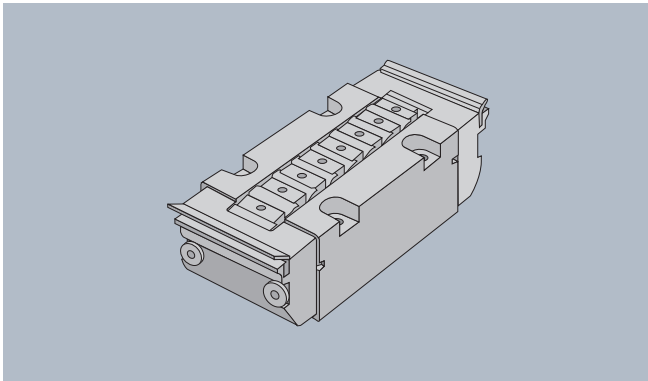

Fig. 1

Bearing accuracy

All the linear roller bearings are manufactured within the dimensional tolerance range of 0 to $-2.5\mu\text{m}$ for bearing height (H). And these bearings are delivered classified into 5-stepped tolerance classes. (See Table 1)

Table 1 Classification of bearing height H by accuracy class

Unit: μm

Class code	Tolerance for height (H)
1H	0 ~ - 5
2H	- 5 ~ -10
3H	-10 ~ -15
4H	-15 ~ -20
5H	-20 ~ -25

Requirements and tolerances for raceway surface and mounting surface

Table 2 shows the requirements and tolerances for the raceway surface, on which linear roller bearing rolls, and the bearing mounting surface. Where adhesion of a hard foreign matter to the raceway surface is forecast, the raceway surface must be protected with a proper protective cover.

The reference surface for mounting is the back face and opposite face to NTN mark.

Table 2 Requirements for raceway surface and mounting surface

Characteristics	Allowable value or tolerance range
Raceway surface roughness (max)	0.2a
Raceway surface hardness	HRC58~64
Effective hardened layer depth of raceway surface (min)	as described in applicable Dimensions Table
Parallelism of mounting surface	
Δx (See Fig. 2)	0.05 mm per 100 mm
Δy (See Fig. 3)	0.01 mm per 100 mm

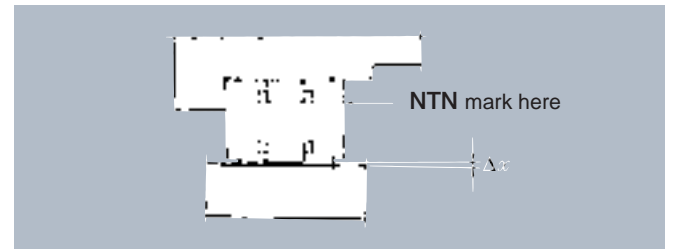

Fig. 2



Fig. 3

How to mount

Fix linear roller bearing using the tapped holes which are provided on the mounting reference surface. (See Fig. 4)

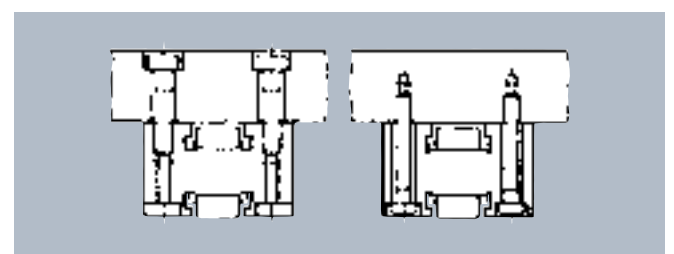
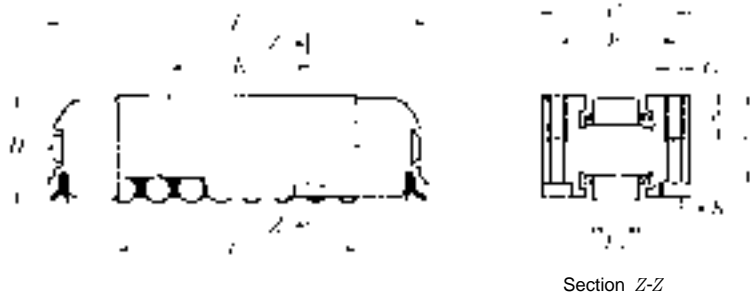

Fig. 4

Type RLM



H 16~38mm

Boundary dimensions											Bearing numbers	Basic load ratings				Required case depth on track (min.) mm	Mass kg (approx.)
mm												dynamic	static	dynamic	static		
<i>H</i>	<i>C</i>	<i>L</i>	<i>L_w</i>	<i>E</i>	<i>F</i>	<i>G</i>	<i>L_t</i>	<i>e</i>	<i>g</i>	<i>K</i>		<i>C_r</i>	<i>C_{0r}</i>	<i>C_r</i>	<i>C_{0r}</i>		
16	25	62	8	17	19	M4	35.5	12.5	6	φ 3.2	RLM16× 62	15 400	34 000	1 570	3 450	0.3	0.11
19	27	69	10	25.5	20.6	M4	43.4	15.5	6	φ 3.2	RLM19× 69	26 100	58 000	2 670	5 900	0.3	0.16
26	40	86	14	28	30	M6	52.4	21	10	φ 4.5	RLM26× 86	50 000	106 000	5 100	10 800	0.4	0.41
26	40	102	14	44	30	M6	67.9	21	10	φ 4.5	RLM26×102	62 500	142 000	6 400	14 500	0.4	0.53
26	40	126	14	68	30	M6	91.8	21	10	φ 4.5	RLM26×126	80 000	195 000	8 150	19 900	0.4	0.70
38	52	134	20	51	41	M8	85.7	31	14	φ 6.5	RLM38×134	124 000	270 000	12 700	27 500	0.5	1.3

One-way Clutches Tension Pulleys, Bottom Roller Bearings

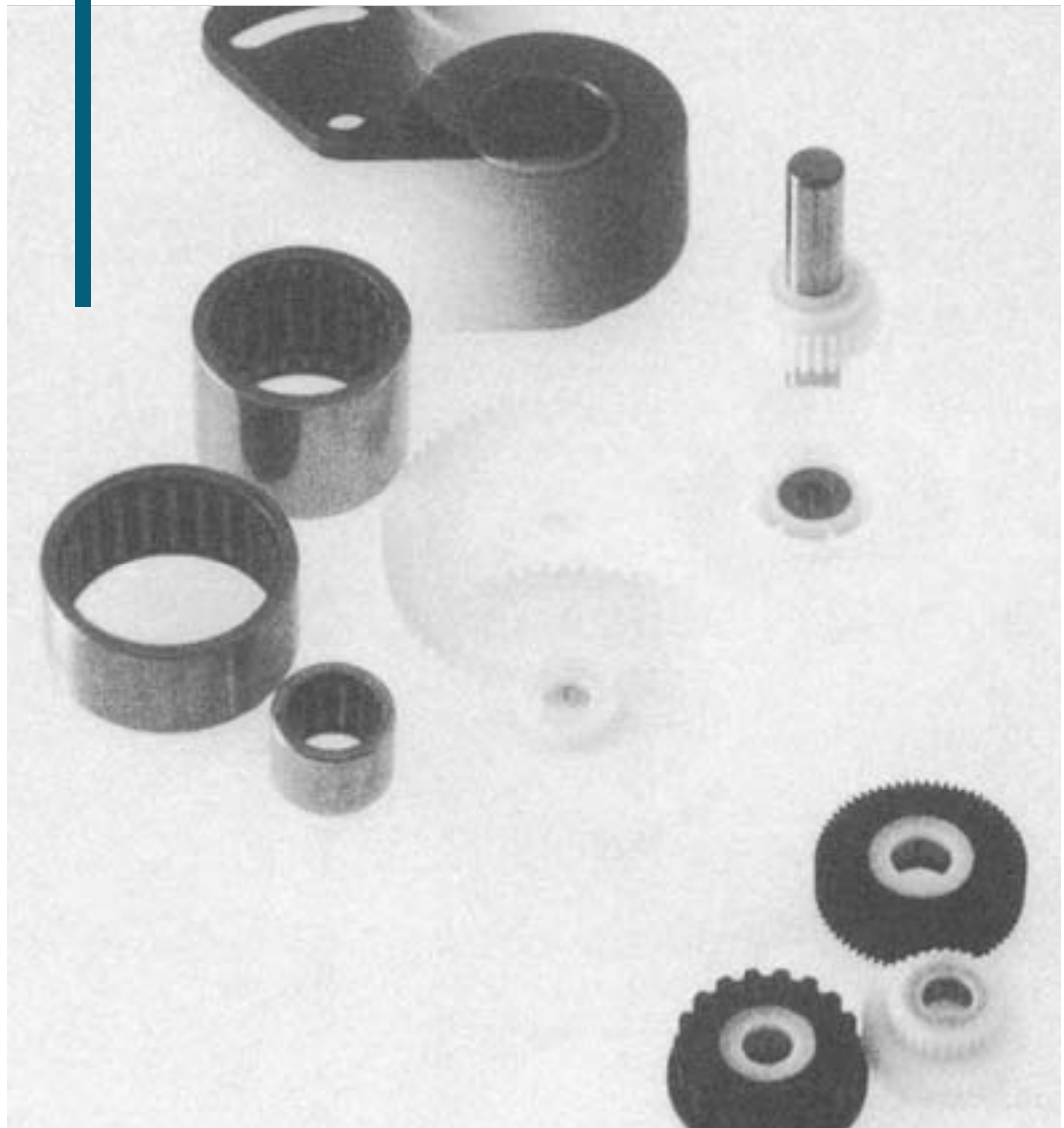

One-way Clutches

This is a compact and roller type one-way clutch which formed a cam face on its outer ring. (Available shaft diameter range: 6 to 35 mm) When the outer ring is going to rotate counterclockwise against shaft rotation (arrow → direction on outer ring widthway surface), the rollers advance to the position of engagement with the outer ring cam face by spring action and drive the shaft by acting as a wedge between the outer ring cam face and the shaft. (See Fig. 1) When the outer ring rotates clockwise against the shaft, the shaft rotates counterclockwise relative to the outer ring and, as the result, the rollers get away from the outer ring cam face and simultaneously the outer ring idles against the shaft. (See Fig. 2)

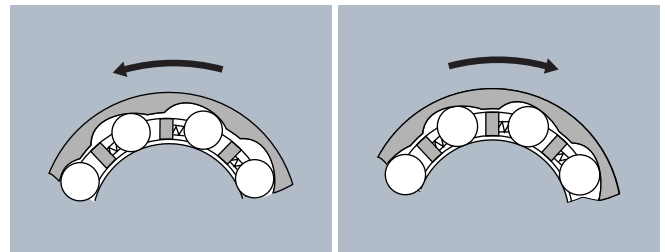

Fig. 1
One-way clutch in engagement

Fig. 2
One-way clutch in idling

Type	Applied shaft diameter (mm)	Composition of nominal clutch number	Remarks
<p>Type HF</p>	$\phi 6 \sim \phi 35$	<p>HF 10 12</p> <p>Width Bore diameter Type code</p>	<p>One-way clutch HF composed of an outer ring drawn from a thin steel plate by precision drawing has the clutching function only.</p> <p>This one-way clutch must be provided with a bearing at its both sides to support radial load acting thereon and to ensure smooth rotating motion.</p>
<p>Type HFL</p>	$\phi 8 \sim \phi 35$	<p>HFL 10 22</p> <p>Width Bore diameter Type code</p>	<p>One-way clutch HFL has an outer ring drawn from thin steel plate by precision drawing, a clutching function, and an integral needle roller and cage assembly capable of supporting radial load at its both ends respectively. Thus, this HFL can function as clutch and, in addition, support radial load.</p>

Both of Type HF and HFL use a polyamide resin cage and press the needle rollers to a wedge, which is formed between the outer ring cam face and the shaft, by action of a plate spring supported with the cage.

Clutch fit

Table 1 shows the one-way clutch fits on shaft and in housing. Both of Type HF and HFL are only press-fitted in a housing, needing no axial fixing by use of a snap ring, etc.

However, due to the outer ring drawn from thin steel by precision drawing, the performance of the both is directly affected by the dimensional and profile deviations of the shaft/housing. To avoid such an inverse affect, shaft and housing accuracy must be controlled with good care. Any housing is required to have the wall thickness of a

specified value or more. Table 2 shows the recommended value.

Table 1 Clutch fits

Type	Shaft	Housing	
		Iron series	Light metal alloy
HF	h5 (h6)	N6 (N7)	R6 (R7)
HFL			

Table 2 Recommended housing wall thickness

Housing material	Housing wall thickness
Steel, cast iron	0.75 ($D - F_w$) and over
Light metal alloy	1.5 ($D - F_w$) and over

Shaft and housing requirements

Table 3 shows the shaft and housing requirements.

Table 3 Shaft and housing requirements (recommended)

Characteristics	Shaft		Housing	
	Type HF	Type HFL	Type HF	Type HFL
Roundness (max)	IT3 (IT4)		IT4 (IT5)	
Cylindricity (max)	IT3 (IT4)		IT4 (IT5)	
Surface roughness	0.2a		1.6a	
Surface hardness	HRC58~64		—	
Effective hardened layer depth (min)	0.4mm		—	

Lubrication

Oil lubrication is optimum for these one-way clutches, but generally grease lubrication is mostly applied to this type of one-way clutch. NTN one-way clutches are filled up with a suitable grease. These clutches need no further grease replenishment, but subject to general applications.

In replenishing, good care must be exercised of too much grease filling. Too much filling could cause interference with smooth clutching.

Allowable operating temperature

For Type HF and HFL ··· Oil lubrication : -10 to 120°C
Grease lubrication : -10 to 70°C

However, consult with NTN for application under temperature exceeding the said temperature range.

How to mount

It is convenient to use a press-fitting mandrel as illustrated in Fig. 3 for assembling and mounting these one-way clutches. In that case, press-fit the outer ring, with its stamped mark side kept in contact with the mandrel shoulder.

In assembling, be careful to prevent the outer ring from twisting. Avoid to hammer directly the outer ring and, in press-fitting, bring a proper jig in contact with the outer ring side face without fail. Furthermore, when press-fitting in an housing with shoulder, good care must be exercised to prevent the bearing side face from coming into contact with the housing shoulder and to thereby avoid deformation of the bearing.

Also, shaft can be easily assembled by turning it in clutch idling direction. Where impossible to do so, provide the shaft end with a tapered (chamfered) guide to facilitate assembling-in.

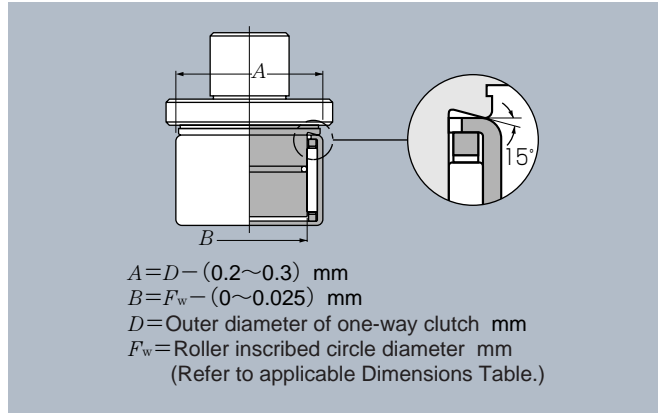

Fig. 3

Precautions in selecting

NTN makes it a rule to conduct functional verification tests on its manufactured one-way clutches under various test conditions. However, be noted that the clutch lifetime could reduce depending on the following factors; application to high load torque, high oscillation cycle and fine oscillation, etc., large radial load acting on one-way clutch unit, and use of a shaft with lower hardness.

Furthermore, lock failure could occur in the cases of fast idling speed, frequent use in idling, and application incurring vibration.

When using these one-way clutches under the special conditions stated above, feel free to contact NTN for further instructions.

When it is forecast that clutching function failure of one-way clutch(ex. clutch slip in engaging) could result in serious damage to person or equipment, appropriate safety devices must be provided separately.

Type HF

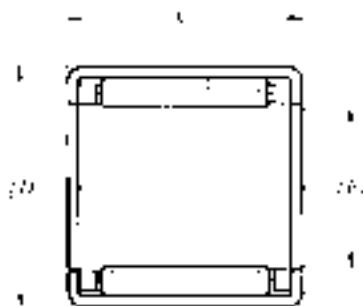

Type HF

F_w 6~35mm

Boundary dimensions			Torque capacity M_d		Bearing numbers	Mass kg (approx.)	Part number by radial load	
F_w	mm D	C 0 -0.25	N·m	kgf·m			(approx.) needle roller bearing oil retaining bearing	
6	10	12	1.76	0.18	HF0612	0.003	HK0609T2	B-S6-22
8	12	12	3.15	0.32	HF0812	0.0035	HK0810	B-S8-25
10	14	12	5.30	0.54	HF1012	0.004	HK1010	B-S10-21
12	18	16	12.2	1.24	HF1216	0.0116	HK1212	B-S12-32
14	20	16	17.3	1.76	HF1416	0.013	HK1412	B-S14-13
16	22	16	20.5	2.09	HF1616	0.014	HK1612	B-S16-13
18	24	16	24.1	2.46	HF1816	0.0155	HK1812	B-S18-8
20	26	16	28.5	2.91	HF2016	0.017	HK2012	B-S20-19
25	32	20	66	6.73	HF2520	0.0309	HK2512	B-S25-11
30	37	20	90	9.18	HF3020	0.036	HK3012	B-S30-19
35	42	20	121	12.3	HF3520	0.040	HK3512	B-S35-7

Remarks: Type HF is subject to delivery of INA product instead.
Type HFL is the imported product from INA, Germany.

Type HFL

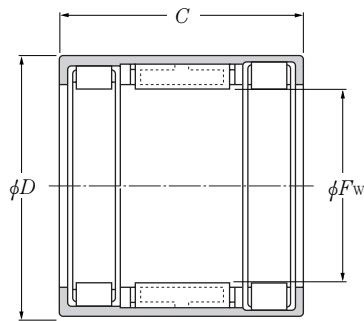

Type HFL

d 8~35mm

Shaft dia. mm d	Boundary dimensions			Basic load ratings				Bearing numbers	Torque capacity		Mass kg (approx.)
	F _w	mm D	C 0 -0.25	dynamic N C _r	static N C _{or}	dynamic kgf C _r	static kgf C _{or}		N·mm	kgf·m	
8	8	12	22	4 050	413	4 150	423	HFL0822	3.15	0.32	0.0063
10	10	14	22	4 300	438	4 650	474	HFL1022	5.30	0.54	0.0074
12	12	18	26	6 300	642	6 500	663	HFL1226	12.2	1.24	0.018
14	14	20	26	7 100	724	7 700	785	HFL1426	17.3	1.76	0.020
16	16	22	26	7 300	744	8 400	857	HFL1626	20.5	2.09	0.022
18	18	24	26	8 300	846	10 300	1 050	HFL1826	24.1	2.46	0.024
20	20	26	26	8 200	836	10 400	1 060	HFL2026	28.5	2.91	0.027
25	25	32	30	10 900	1 110	14 100	1 440	HFL2530	66.0	6.73	0.044
30	30	37	30	12 600	1 280	17 600	1 790	HFL3030	90.0	9.18	0.051
35	35	42	30	13 000	1 330	19 300	1 970	HFL3530	121	12.3	0.058

Bottom Roller Bearings for Textile Machinery

These bottom roller bearings for textile machinery are grease-prefilled needle roller bearings intended to support the bottom rollers (fluted rollers) of a fine spinning machine, a roving frame or a drawing frame. **Type FRIS** is applied to a fine spinning machine and a roving frame, and **Type FR** applied to a drawing frame.

Types and construction

Bottom roller bearing **FRIS** is used to support the bottom rollers of a fine spinning machine and a roving frame. The outer ring outer profile of this bearing type is spherical, which can allow, to some extent, mounting error in the bottom rollers. On the other hand, the inner ring is provided with a rib at its both ends and a clearance between the outer ring and each inner ring rib is minimized. Furthermore, the rib outer surface is knurled to prevent invasion of cotton pieces into the bearing.

These bottom roller bearings are classified into internationally interchangeable **A-series** bearings with bearing fixing saddle (to fix a bearing to a support stand) and **B-series** bearings adaptable to the dimensions of JIS Fluted Rollers.

A-series bearings are further classified into one bearing type (bearing number + tail code **SA**) wherein inner ring and outer ring are separable from one another according to saddle type and another bearing type (bearing number + tail code **SB**) wherein inner ring and outer ring are non-separable. Of course, these bearings can also be supplied without saddle.

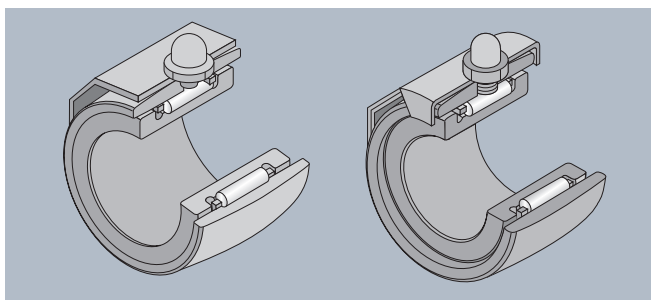

Fig. 1 Type FRIS · SA

Fig. 2 Type FRIS · SB

On the other hand, **B-series** bearings are further classified into bearing type with grease nipple (bearing number + tail code **N**), bearing type with knock pin on its outer ring (bearing number + tail code **P**) and bearing type with knock hole on its outer ring (bearing number +

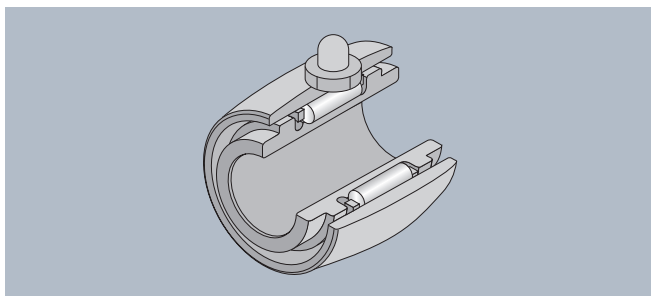

Fig.3 Type FRIS

W) (latter two types—classified by the fixing method applied).

These bearings can be supplied with saddle thereon on request, similarly to A-series.

Type **FR** is used to support the rollers of a drawing frame. This bearing type is composed of two drawn cup type needle roller bearings which are configured in a housing. These have no inner ring and use a shaft as the direct raceway surface. Synthetic rubber seal is fitted in the both ends of the housing. This bearing type is fixed to a support stand with knock pins press-fitted in the housing. The knock pin is provided with an grease hole to enable grease replenishing.

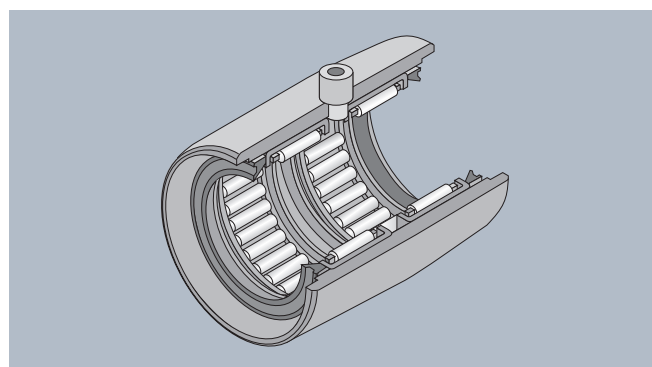

Fig. 4 Type FR

Nominal bearing number

Nominal bearing number comprises type code, dimension code [shaft dia. (d or F_w)] and tail code.

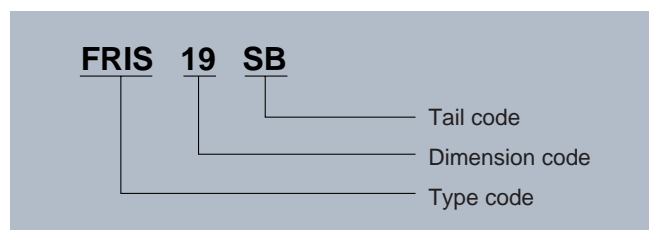

Fig.5

Bearing fits

Table 1 shows bearing fits on/in shaft and housing.

Table 1 Bearing fits

Bearing type	Shaft		Housing (stand)
	Screwed joint	Spline joint	
FRIS	g5 (g6)	j5 (j6)	H10
FR	h5 (h6)		H10

Type FRIS Series A (For fine spinning machine/ roving frame)

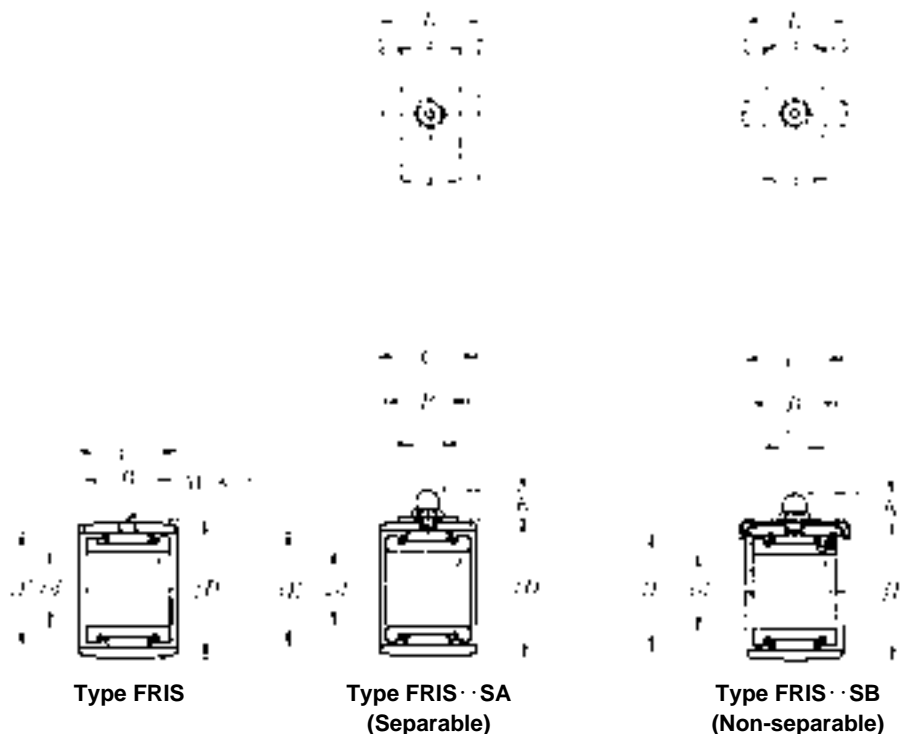

d 16.5~25mm

Boundary dimensions									Basic load ratings			
d -0.010	D	B -0.050	C -0.120	E	$r_s \text{ min}^{1)}$	L	K	dynamic	static	dynamic	static	
								N		kgf		
								C_r	C_{or}	C_r	C_{or}	
16.5	28 ⁰ _{-0.020}	19	22	23.5	0.3	22.2	7.7	10 200	14 600	1 040	1 480	
19	32 ⁰ _{-0.025}	20	23	27	0.3	22.2	7.7	11 800	18 500	1 200	1 880	
	36	22	25	29	0.3	22.2	9.8	12 700	17 600	1 300	1 800	
22	42 ⁰ _{-0.025}	25	29	35	0.3	26.4	10.2	19 500	25 300	1 980	2 580	
25	45 ⁰ _{-0.025}	25	29	37	0.3	26.4	10.2	21 300	29 100	2 170	2 970	

Note 1) Allowable minimum chamfer dimension r .

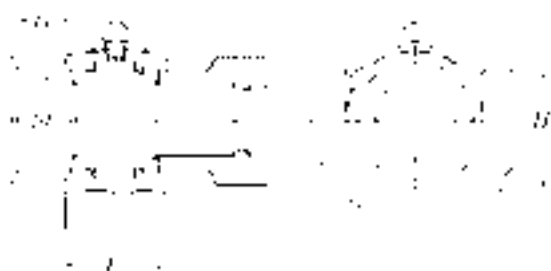

Bearing numbers			Abutment dimensions				Mass
bearing	bearing with saddle		mm				kg bearing with saddle (approx.)
	Type SA	Type SB	L_1	d_1	G	H	
FRIS16.5	FRIS16.5SA	FRIS16.5SB	22	21	13	24~26	0.059
FRIS19	FRIS19SA	FRIS19SB	22	24	15	27~29	0.081
FRIS19-5	FRIS19-5SA	FRIS19-5SB	22	26	15	30~32	0.120
FRIS22-2	FRIS22-2SA	—	26	30	15	35~37	0.208
FRIS25	FRIS25SA	—	26	33	15	37~39	0.226

Type FRIS Series B (For fine spinning machine/ roving frame)



Type FRIS



Type FRIS·NP
(With grease nipple/knock pin)²⁾

d 15~25mm

d 0 -0.010	Boundary dimensions						Basic load ratings				Bearing numbers		Mass (approx.) kg Type FRIS·NP	
	D	mm		J	r _s min ¹⁾	K	dynamic N	static N	dynamic kgf	static kgf	Type FRIS	Type FRIS·NP		
		B	C				C _r	C _{or}	C _r	C _{or}				
15	28	⁰ _{-0.020}	24	22	22	0.3	7.7	10 200	14 600	1 040	1 480	FRIS15	FRIS15NP	0.070
15.875	30	⁰ _{-0.020}	25.4	22	22	0.3	7.1	10 200	14 600	1 040	1 480	FRIS15.87	FRIS15.87NP	0.082
16	28	⁰ _{-0.020}	26	22	22	0.3	7.7	10 200	14 600	1 040	1 480	FRIS16	FRIS16NP	0.083
	30	⁰ _{-0.020}	26	22	22	0.3	7.1	10 200	14 600	1 040	1 480	FRIS16-2	FRIS16-2NP	0.098
18	31.750	⁰ _{-0.025}	24	23	24	0.3	7.7	11 800	18 500	1 200	1 880	FRIS18	FRIS18NP	0.083
	32	⁰ _{-0.025}	26	23	24	0.3	7.7	11 800	18 500	1 200	1 880	FRIS18-2	FRIS18-2NP	0.088
19.050	31.750	⁰ _{-0.025}	23.81	23	24	0.3	7.7	11 800	18 500	1 200	1 880	FRIS19.05	FRIS19.05NP	0.078
	34	⁰ _{-0.025}	25.4	23	26	0.3	7.7	12 700	17 600	1 300	1 800	FRIS19.05-1	FRIS19.05-1NP	0.098
20	34	⁰ _{-0.025}	24	23	26	0.3	7.7	12 700	17 600	1 300	1 800	FRIS20-2	FRIS20-2NP	0.089
	34	⁰ _{-0.025}	26	23	26	0.3	7.7	12 700	17 600	1 300	1 800	FRIS20-4	FRIS20-4NP	0.097
	36	⁰ _{-0.025}	26	23	26	0.3	7.1	12 700	17 600	1 300	1 800	FRIS20-7	FRIS20-7NP	0.125
22	40	⁰ _{-0.025}	26	24	30	0.6	7.1	16 200	22 300	1 650	2 280	FRIS22-1	FRIS22-1NP	0.154
22.225	40	⁰ _{-0.025}	25.4	24	30	0.6	7.1	16 200	22 300	1 650	2 280	FRIS22.22	FRIS22.22NP	0.145
25	42	⁰ _{-0.025}	26	24	32	0.6	7.1	16 000	22 500	1 640	2 290	FRIS25-1	FRIS25-1NP	0.154
	44	⁰ _{-0.025}	26	24	34	0.6	7.1	17 200	25 100	1 750	2 560	FRIS25-2	FRIS25-2NP	0.174

Note 1) Allowable minimum chamfer dimension ?.

2) Example of bearing with grease nipple: Ex. FRIS 18N
Bearing with knock pin only: Ex. FRIS 15.87P

Type FR
(Drawing frame)



Type FR

F_w 17.462~22mm

F_w	Boundary dimensions							Basic load ratings				Bearing numbers	Mass kg (approx.)
	D 0 -0.050	C 0 -0.20	mm E G		H	K	D_1	dynamic N C_r	static C_{or}	dynamic kgf C_r	static C_{or}		
17.462 $+0.053$ $+0.010$	26.5	46	24	31	5	5	26	10 200	16 600	1 040	1 690	FR17.46P	0.066
	26.5	47.6	24.6	42.86	4.76	4.76	26	14 400	25 900	1 470	2 640	FR17.46-1P	0.075
	26.5	52.38	24.6	42.86	4.76	4.76	26	14 400	25 900	1 470	2 640	FR17.46-2P	0.082
	26.988	41.28	24	31	5	5	26.5	10 200	16 600	1 040	1 690	FR17.46-3P	0.068
19.050 $+0.053$ $+0.020$	31.750	52.38	28	42.86	4.76	4.76	31.2	16 700	25 800	1 700	2 630	FR19.05P	0.134
22 $+0.053$ $+0.020$	34	46	28	43	4.76	4.76	33.5	23 400	44 000	2 380	4 500	FR22P	0.150

Tensioner Pulleys for Textile Machinery

These pulleys are used to guide and tension the tapes and belts driving the spindles of a fine spinning machine, a roving frame, a false twister, etc.

A pulley drawn precisely from steel plate by precision deep drawing is press-fitted in the outer ring of shaft bearing in place of inner ring.

Types and construction

Single-row or double-row ball bearing is built in this pulley, which is internally pre-filled with lithium soap base grease. Grease is replenished through a grease hole which is internally provided in the stud. Two different mounting methods are available as follows for these pulleys; one method is to bolt a pulley to the roller carrier of machine with holder bolt using a special-purposed holder (Type code: **JF** · **S**) and another method is to bolt directly a pulley to machine frame using the bolting hole drilled in the stud and a corresponding hexagon head bolt. A knock pin press-fitted in the stud end face is to lock the bolt after tightened.

When a pulley is directly bolted to machine frame, provide the hexagon head bolt center with a grease through-hole for grease replenishing and screw a grease nipple in its end face.

In mounting a double-row ball bearing type tension pulley, insert the stud directly into machine frame and tighten it with nut, without using the special-purposed holder. Replenish grease using the box nut.

Composition of nominal number

Nominal number comprises type code (**JPU** · **S**), dimension code (Pulley outer dia. (*D*)) and tail code. Tension pulley with special-purposed holder is represented by nominal number + tail code (holder nominal number).

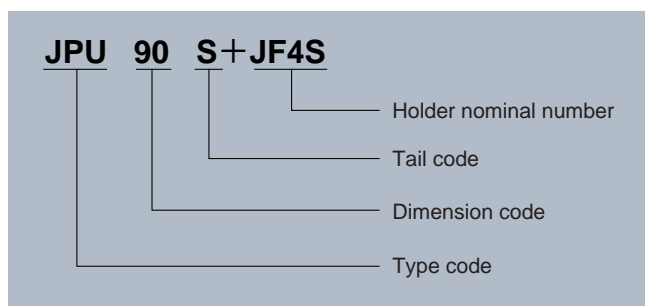
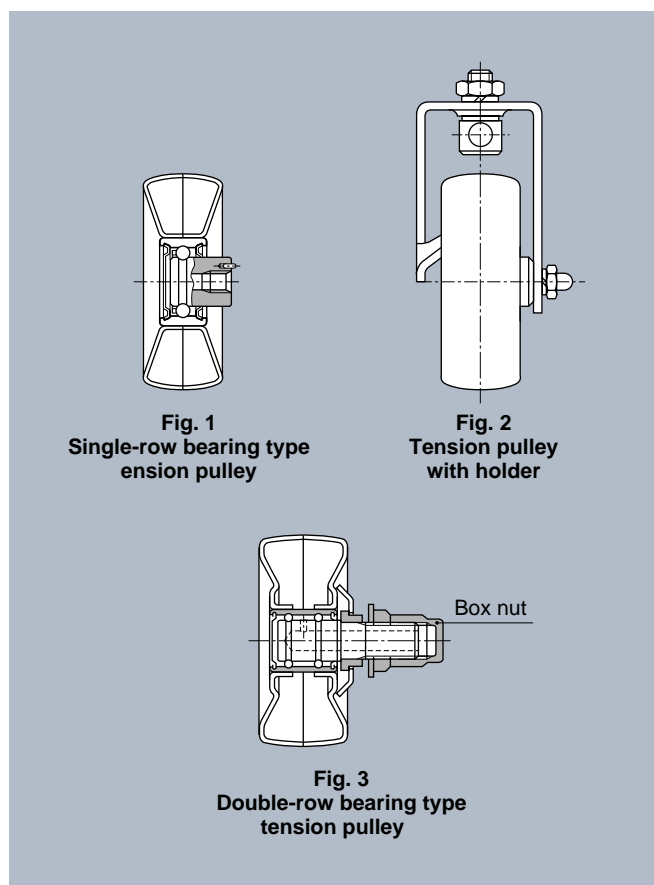

Fig. 4





Example 1



Example 2

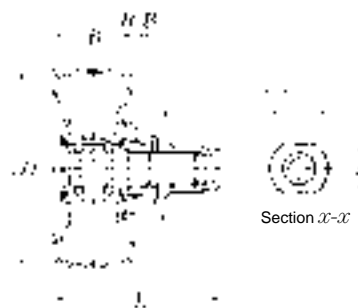

Example 3

D 60~100mm

Boundary dimensions										Bearing numbers	Sample number	Mass kg (approx.)
D	B	B ₁	H	mm								
				d_1 0 -0.3	a	b	S	L	B ₂			
60	25	—	3.5	—	—	—	—	—	—	JPU60S	1	0.140
	25	—	3.5	—	—	—	—	—	—	JPU70S	1	0.160
70	25	—	3.5	—	48	39	10.2	—	—	JPU70S+JF1S	2	0.235
	30	2	—	21	—	—	—	67 ~ 71	5~9	JPU70-2S	3	0.245
	32	—	—	—	—	—	—	—	—	JPU70-1S	1	0.175
	32	—	—	—	48	46	10.2	—	—	JPU70-1S+JF2S	2	0.250
90	25	—	3.5	—	—	—	—	—	—	JPU90S	1	0.215
	25	—	3.5	—	58	39	10.2	—	—	JPU90S+JF3S	2	0.300
	32	—	—	—	—	—	—	—	—	JPU90-1S	1	0.230
	32	—	—	—	58	46	10.2	—	—	JPU90-1S+JF4S	2	0.320
	32	3.5	—	21	—	—	—	70.5~74.5	5~9	JPU90-9S	3	0.325
	45	3.5	—	21	—	—	—	83.5~87.5	5~9	JPU90-10S	3	0.380
100	32	3.5	—	21	—	—	—	70.5~74.5	5~9	JPU100-14S	3	0.290
	40	3.5	—	21	—	—	—	78.5~82.5	5~9	JPU100-12S	3	0.390

Contents of Appendix

Approximate conversion values against Rockwell C hardness of steel materials	···C-2
°C-°F temperature conversion table	·····C-3
Approximate conversion values against Vickers hardness of steel materials	···C-4
Contrast table of SI and CGS system units, gravitation system units	·····C-6
Conversion to SI units	·····C-6
Integer multiplication of SI unit 10	·····C-7
kgf-N conversion table	·····C-8
Viscosity conversion table	·····C-9
Ordinary tolerance for cutting dimensions	·····C-10
Ordinary tolerances for castings	·····C-10
Ordinary tolerances for press-formed metal parts	·····C-10
Ordinary tolerance for die casts	·····C-11
Ordinary tolerances for sheared metal plates	·····C-12
Ordinary tolerance for sintered metal parts	·····C-13
Ordinary tolerance for steel castings	·····C-14
Ordinary tolerance for aluminum alloy castings	·····C-14
Ordinary tolerance for length	·····C-15
Ordinary tolerance for wall thickness	·····C-15
Maximum draft angle value	·····C-15
Tolerance for shaft diameter	·····C-16
Dimensional tolerance for housing bore	·····C-18
Inch - Millimeter conversion table	·····C-20

Approximate conversion values against Rockwell C hardness of steel materials¹⁾

Rockwell C scale hardness ²⁾	Pickers hardness (DPH)	Brinell hardness 100 mm ball, load 3000 kgf			Rockwell hardness ²⁾			Rockwell special hardness special brake indenter			Shore hardness	Tensile strength kgf/mm ² Approx. value	Rockwell C scale hardness ²⁾
		Standard ball	Hultgren ball	Tungsten carbide ball	A scale Load 60kgf brale indenter	B scale Load 100 kgf dia. 1/16in. ball	D-scale Load 100 kgf brale indenter	15-N scale Load 15 kgfkgf	30-N scale Load 30 kgf	45-N scale load 45 kgf			
68	940	—	—	—	85.6	—	76.9	93.2	84.4	75.4	97	—	68
67	900	—	—	—	85.0	—	76.1	92.9	83.6	74.2	95	—	67
66	865	—	—	—	84.5	—	75.4	92.5	82.8	73.3	92	—	66
65	832	—	—	739	83.9	—	74.5	92.2	81.9	72.0	91	—	65
64	800	—	—	722	83.4	—	73.8	91.8	81.1	71.0	88	—	64
63	772	—	—	705	82.8	—	73.0	91.4	80.1	69.9	87	—	63
62	746	—	—	688	82.3	—	72.2	91.1	79.3	68.8	85	—	62
61	720	—	—	670	81.8	—	71.5	90.7	78.4	67.7	83	—	61
60	697	—	613	654	81.2	—	70.7	90.2	77.5	66.6	81	—	60
59	674	—	599	634	80.7	—	69.9	89.8	76.6	65.5	80	—	59
58	653	—	587	615	80.1	—	69.2	89.3	75.7	64.3	78	—	58
57	633	—	575	595	79.6	—	68.5	88.9	74.8	63.2	76	—	57
56	613	—	561	577	79.0	—	67.7	88.3	73.9	62.0	75	—	56
55	595	—	546	560	78.5	—	66.9	87.9	73.0	60.9	74	212	55
54	577	—	534	543	78.0	—	66.1	87.4	72.0	59.8	72	205	54
53	560	—	519	525	77.4	—	65.4	86.9	71.2	58.6	71	199	53
52	544	500	508	512	76.8	—	64.6	86.4	70.2	57.4	69	192	52
51	528	487	494	496	76.3	—	63.8	85.9	69.4	56.1	68	186	51
50	513	475	481	481	75.9	—	63.1	85.5	68.5	55.0	67	179	50
49	498	464	469	469	75.2	—	62.1	85.0	67.6	53.8	66	172	49
48	484	451	455	455	74.7	—	61.4	84.5	66.7	52.5	64	167	48
47	471	442	443	443	74.1	—	60.8	83.9	65.8	51.4	63	161	47
46	458	432	432	432	73.6	—	60.0	83.5	64.8	50.3	62	156	46
45	446	421	421	421	73.1	—	59.2	83.0	64.0	49.0	60	151	45
44	434	409	409	409	72.5	—	58.5	82.5	63.1	47.8	58	146	44
43	423	400	400	400	72.0	—	57.7	82.0	62.2	46.7	57	141	43
42	412	390	390	390	71.5	—	56.9	81.5	61.3	45.5	56	136	42
41	402	381	381	381	70.9	—	56.2	80.9	60.4	44.3	55	132	41
40	392	371	371	371	70.4	—	55.4	80.4	59.5	43.1	54	127	40
39	382	362	362	362	69.9	—	54.6	79.9	58.6	41.9	52	124	39
38	372	353	353	353	69.4	—	53.8	79.4	57.7	40.8	51	120	38
37	363	344	344	344	68.9	—	53.1	78.8	56.8	39.6	50	118	37
36	354	336	336	336	68.4	(109.0)	52.3	78.3	55.9	38.4	49	114	36
35	345	327	327	327	67.9	(108.5)	51.5	77.7	55.0	37.2	48	110	35
34	336	319	319	319	67.4	(108.0)	50.8	77.2	54.2	36.1	47	108	34
33	327	311	311	311	66.8	(107.5)	50.0	76.6	53.3	34.9	46	105	33
32	318	301	301	301	66.3	(107.0)	49.2	76.1	52.1	33.7	44	102	32
31	310	294	294	294	65.8	(106.0)	48.4	75.6	51.3	32.5	43	100	31
30	302	286	286	286	65.3	(105.5)	47.7	75.0	50.4	31.3	42	97	30
29	294	279	279	279	64.7	(104.5)	47.0	74.5	49.5	30.1	41	95	29
28	286	271	271	271	64.3	(104.0)	46.1	73.9	48.6	28.9	41	93	28
27	279	264	264	264	63.8	(103.0)	45.2	73.3	47.7	27.8	40	90	27
26	272	258	258	258	63.3	(102.5)	44.6	72.8	46.8	26.7	38	88	26
25	266	253	253	253	62.8	(101.5)	43.8	72.2	45.9	25.5	38	86	25
24	260	247	247	247	62.4	(101.0)	43.1	71.6	45.0	24.3	37	84	24
23	254	243	243	243	62.0	100.0	42.1	71.0	44.0	23.1	36	82	23
22	248	237	237	237	61.5	99.0	41.6	70.5	43.2	22.0	35	80	22
21	243	231	231	231	61.0	98.5	40.9	69.9	42.3	20.7	35	79	21
20	238	226	226	226	60.5	97.8	40.1	69.4	41.5	19.6	34	77	20
(18)	230	219	219	219	—	96.7	—	—	—	—	33	75	(18)
(16)	222	212	212	212	—	95.5	—	—	—	—	32	72	(16)
(14)	213	203	203	203	—	93.9	—	—	—	—	31	69	(14)
(12)	204	194	194	194	—	92.3	—	—	—	—	29	66	(12)
(10)	196	187	187	187	—	90.7	—	—	—	—	28	63	(10)
(8)	188	179	179	179	—	89.5	—	—	—	—	27	61	(8)
(6)	180	171	171	171	—	87.1	—	—	—	—	26	59	(6)
(4)	173	165	165	165	—	85.5	—	—	—	—	25	56	(4)
(2)	166	158	158	158	—	83.5	—	—	—	—	24	54	(2)
(0)	160	152	152	152	—	81.7	—	—	—	—	24	53	(0)

Note 1) Approximate values were determined from "Conversion Tables" of JIS Z 8413 and Z 8438.

2) Some of the parenthesized values in the above table are not used so frequently.

°C-°F temperature conversion table

°C		F	°C		F	°C		F	°C		F
-73	-100	-148	-1.6	29	84.2	17.7	64	147.2	37.1	99	210.2
-62	- 80	-112	-1.1	30	86.0	18.2	65	149.0	37.7	100	212
-51	- 60	- 76	-0.6	31	87.8	18.8	66	150.8	40.6	105	221
-40	- 40	- 40	0	32	89.6	19.3	67	152.6	43	110	230
-29	- 20	- 4	0.5	33	91.4	19.9	68	154.4	49	120	248
-23.3	- 10	14	1.1	34	93.2	20.4	69	156.2	54	130	266
-17.7	0	32	1.6	35	95.0	21.0	70	158.0	60	140	284
-17.2	1	33.8	2.2	36	96.8	21.5	71	159.8	65	150	302
-16.6	2	35.6	2.7	37	98.6	22.2	72	161.6	71	160	320
-16.1	3	37.4	3.3	38	100.4	22.7	73	163.4	76	170	338
-15.5	4	39.2	3.8	39	102.2	23.3	74	165.2	83	180	356
-15.0	5	41.0	4.4	40	104.0	23.8	75	167.0	88	190	374
-14.4	6	42.8	4.9	41	105.8	24.4	76	168.8	93	200	392
-13.9	7	44.6	5.4	42	107.6	25.0	77	170.6	121	250	482
-13.3	8	46.4	6.0	43	109.4	25.5	78	172.4	149	300	572
-12.7	9	48.2	6.6	44	111.2	26.2	79	174.2	177	350	662
-12.2	10	50.0	7.1	45	113.0	26.8	80	176.0	204	400	752
-11.6	11	51.8	7.7	46	114.8	27.3	81	177.8	232	450	842
-11.1	12	53.6	8.2	47	116.6	27.7	82	179.6	260	500	932
-10.5	13	55.4	8.8	48	118.4	28.2	83	181.4	288	550	1 022
-10.0	14	57.2	9.3	49	120.2	28.8	84	183.2	315	600	1 112
- 9.4	15	59.0	9.9	50	122.0	29.3	85	185.0	343	650	1 202
- 8.8	16	61.8	10.4	51	123.8	29.9	86	186.8	371	700	1 292
- 8.3	17	63.6	11.1	52	125.6	30.4	87	188.6	399	750	1 382
- 7.7	18	65.4	11.5	53	127.4	31.0	88	190.4	426	800	1 472
- 7.2	19	67.2	12.1	54	129.2	31.5	89	192.2	454	850	1 562
- 6.6	20	68.0	12.6	55	131.0	32.1	90	194.0	482	900	1 652
- 6.1	21	69.8	13.2	56	132.8	32.6	91	195.8	510	950	1 742
- 5.5	22	71.6	13.7	57	134.6	33.3	92	197.6	538	1 000	1 832
- 5.0	23	73.4	14.3	58	136.4	33.8	93	199.4	593	1 100	2 012
- 4.4	24	75.2	14.8	59	138.2	34.4	94	201.2	648	1 200	2 192
- 3.9	25	77.0	15.6	60	140.0	34.9	95	203.0	704	1 300	2 372
- 3.3	26	78.8	16.1	61	141.8	35.5	96	204.8	760	1 400	2 552
- 2.8	27	80.6	16.6	62	143.6	36.1	97	206.6	815	1 500	2 732
- 2.2	28	82.4	17.1	63	145.4	36.6	98	208.4	871	1 600	2 937

(How to read this table)

For example, for conversion from 38°C to °F read 38 in 4th row box (10th line from the top) and then read the right-side °F box. 38°C is equivalent to 100.4°F upon reading. Furthermore, for conversion from 38°F to °C read the left-side °C box.

°F38 is equivalent to 3.3°C upon reading.

$$C = 5/9(F - 32)$$

$$F = 9/5C + 32$$

Approximate conversion values against Vickers hardness of steel materials

Vickers hardness (DPH)	Brinell hardness 10 mm ball, load 3000 kgf			Rockwell hardness ²⁾				Rockwell special hardness special brake indenter			Shore hardness	Tensile strength kgf/mm ² Approx. value	Vickers hardness Load 50kgf
	Standard ball	Hultgren ball	Tungsten carbide ball	A scale Load 60 kgf brale indenter	B scale Load 100 kgf dia. 1/16in. ball	C-scale Load 150 kgf brale indenter	D-scale Load 100 kgf brale indenter	15-N scale Load 15 kgf	30-N scale Load 30 kgf	45-N scale load 45 kgf			
940	—	—	—	85.6	—	68.0	76.9	93.2	84.4	75.4	97	—	940
920	—	—	—	85.3	—	67.5	76.5	93.0	84.0	74.8	96	—	920
900	—	—	—	85.0	—	67.0	76.1	92.9	83.6	74.2	95	—	900
880	—	—	767	84.7	—	66.4	75.7	92.7	83.1	73.6	93	—	880
860	—	—	757	84.4	—	65.9	75.3	92.5	82.7	73.1	92	—	860
840	—	—	745	84.1	—	65.3	74.8	92.3	82.2	72.2	91	—	840
820	—	—	733	83.8	—	64.7	74.3	92.1	81.7	71.8	90	—	820
800	—	—	722	83.4	—	64.0	73.8	91.8	81.1	71.0	88	—	800
780	—	—	710	83.0	—	63.3	73.3	91.5	80.4	70.2	87	—	780
760	—	—	698	82.6	—	62.5	72.6	91.2	79.7	69.4	86	—	760
740	—	—	684	82.2	—	61.8	72.1	91.0	79.1	68.6	84	—	740
720	—	—	670	81.8	—	61.0	71.5	90.7	78.4	67.7	83	—	720
700	—	615	656	81.3	—	60.1	70.8	90.3	77.6	66.7	81	—	700
690	—	610	647	81.1	—	59.7	70.5	90.1	77.2	66.2	—	—	690
680	—	603	638	80.8	—	59.2	70.1	89.8	76.8	65.7	80	—	680
670	—	597	630	80.5	—	58.8	69.8	89.7	76.4	65.3	—	—	670
660	—	590	620	80.3	—	58.3	69.4	89.5	75.9	64.7	79	—	660
650	—	585	611	80.0	—	57.8	69.0	89.2	75.5	64.1	—	—	650
640	—	578	601	79.8	—	57.3	68.7	89.0	75.1	63.5	77	—	640
630	—	571	591	79.5	—	56.8	68.3	88.8	74.6	63.0	—	—	630
620	—	564	582	79.2	—	56.3	67.9	88.5	74.2	62.4	75	—	620
610	—	557	573	78.9	—	55.7	67.5	88.2	73.6	61.7	—	—	610
600	—	550	564	78.6	—	55.2	67.0	88.0	73.2	61.2	74	—	600
590	—	542	554	78.4	—	54.7	66.7	87.8	72.7	60.5	—	210	590
580	—	535	545	78.0	—	54.1	66.2	87.5	72.1	59.9	72	206	580
570	—	527	535	77.8	—	53.6	65.8	87.2	71.7	59.3	—	202	570
560	—	519	525	77.4	—	53.0	65.4	86.9	71.2	58.6	71	199	560
550	505	512	517	77.0	—	52.3	64.8	86.6	70.5	57.8	—	195	550
540	496	503	507	76.7	—	51.7	64.4	86.3	70.0	57.0	69	190	540
530	488	495	497	76.4	—	51.1	63.9	86.0	69.5	56.2	—	186	530
520	480	487	488	76.1	—	50.5	63.5	85.7	69.0	55.6	67	183	520
510	473	479	479	75.7	—	49.8	62.9	85.4	68.3	54.7	—	179	510
500	465	471	471	75.3	—	49.1	62.2	85.0	67.7	53.9	66	174	500
490	456	460	460	74.9	—	48.4	61.6	84.7	67.1	53.1	—	169	490
480	448	452	452	74.5	—	47.7	61.3	84.3	66.4	52.2	64	165	480
470	441	442	442	74.1	—	46.9	60.7	83.9	65.7	51.3	—	160	470
460	433	433	433	73.6	—	46.1	60.1	83.6	64.9	50.4	62	156	460
450	425	425	425	73.3	—	45.3	59.4	83.2	64.3	49.4	—	153	450
440	415	415	415	72.8	—	44.5	58.8	82.8	63.5	48.4	59	149	440
430	405	405	405	72.3	—	43.6	58.2	82.3	62.7	47.4	—	144	430
420	397	397	397	71.8	—	42.7	57.5	81.8	61.9	46.4	57	140	420
410	388	388	388	71.4	—	41.8	56.8	81.4	61.1	45.3	—	136	410
400	379	379	379	70.8	—	40.8	56.0	81.0	60.2	44.1	55	131	400
390	369	369	369	70.3	—	39.8	55.2	80.3	59.3	42.9	—	127	390
380	360	360	360	69.8	(110.0)	38.8	54.4	79.8	58.4	41.7	52	123	380

continued

Vickers hardness (DPH)	Brinell hardness 10 mm ball, load 3000 kgf			Rockwell hardness ²⁾				Rockwell special hardness special brake indenter			Shore hardness	Tensile strength kgf/mm ² Approx. value	Vickers hardness Load 50kgf
	Standard ball	Hultgren ball	Tungsten carbide ball	A scale Load 60 kgf brale indenter	B scale Load 100 kgf dia. 1/16in. ball	C-scale Load 150 kgf brale indenter	D-scale Load 100 kgf brale indenter	15-N scale Load 15 kgf	30-N scale Load 30 kgf	45-N scale load 45 kgf			
370	350	350	350	69.2	—	37.7	53.6	79.2	57.4	40.4	—	120	370
360	341	341	341	68.7	(109.0)	36.6	52.8	78.6	56.4	39.1	50	115	360
350	331	331	331	68.1	—	35.5	51.9	78.0	55.4	37.8	—	112	350
340	322	322	322	67.6	(108.0)	34.4	51.1	77.4	54.4	36.5	47	109	340
330	313	313	313	67.0	—	33.3	50.2	76.8	53.6	35.2	—	105	330
320	303	303	303	66.4	(107.0)	32.2	49.4	76.2	52.3	33.9	45	103	320
310	294	294	294	65.8	—	31.0	48.4	75.6	51.3	32.5	—	100	310
300	284	284	284	65.2	(105.5)	29.8	47.5	74.9	50.2	31.1	42	97	300
295	280	280	280	64.8	—	29.2	47.1	74.6	49.7	30.4	—	96	295
290	275	275	275	64.5	(104.5)	28.5	46.5	74.2	49.0	29.5	41	94	290
285	270	270	270	64.2	—	27.8	46.0	73.8	48.4	28.7	—	92	285
280	265	265	265	63.8	(103.5)	27.1	45.3	73.4	47.8	27.9	40	91	280
275	261	261	261	63.5	—	26.4	44.9	73.0	47.2	27.1	—	89	275
270	256	256	256	63.1	(102.0)	25.6	44.3	72.6	46.4	26.2	38	87	270
265	252	252	252	62.7	—	24.8	43.7	72.1	45.7	25.2	—	86	265
260	247	247	247	62.4	(101.0)	24.0	43.1	71.6	45.0	24.3	37	84	260
255	243	243	243	62.0	—	23.1	42.2	71.1	44.2	23.2	—	82	255
250	238	238	238	61.6	99.5	22.2	41.7	70.6	43.4	22.2	36	81	250
245	233	233	233	61.2	—	21.3	41.1	70.1	42.5	21.1	—	79	245
240	228	228	228	60.7	98.1	20.3	40.3	69.6	41.7	19.9	34	78	240
230	219	219	219	—	96.7	(18.0)	—	—	—	—	33	75	230
220	209	209	209	—	95.0	(15.7)	—	—	—	—	32	71	220
210	200	200	200	—	93.4	(13.4)	—	—	—	—	30	68	210
200	190	190	190	—	91.5	(11.0)	—	—	—	—	29	65	200
190	181	181	181	—	89.5	(8.5)	—	—	—	—	28	62	190
180	171	171	171	—	87.1	(6.0)	—	—	—	—	26	59	180
170	162	162	162	—	85.0	(3.0)	—	—	—	—	25	56	170
160	152	152	152	—	81.7	(0.0)	—	—	—	—	24	53	160
150	143	143	143	—	78.7	—	—	—	—	—	22	50	150
140	133	133	133	—	75.0	—	—	—	—	—	21	46	140
130	124	124	124	—	71.2	—	—	—	—	—	20	44	130
120	114	114	114	—	66.7	—	—	—	—	—	—	40	120
110	105	105	105	—	62.3	—	—	—	—	—	—	—	110
100	95	95	95	—	56.2	—	—	—	—	—	—	—	100
95	90	90	90	—	52.0	—	—	—	—	—	—	—	95
90	86	86	86	—	48.0	—	—	—	—	—	—	—	90
85	81	81	81	—	41.0	—	—	—	—	—	—	—	85

1) Some of the parenthesized values in the above table are not used so frequently.

2) Approximate values were determined from "Conversion Tables" of JIS Z 8413 and Z 8438.

Contrast table of SI and CGS system units, gravitation system units

Unit system	Length <i>L</i>	Mass <i>M</i>	Time <i>T</i>	Acceleration	Force	Stress	Pressure	Energy
SI	m	kg	s	m/s ²	N	Pa	Pa	J
CGS system	cm	g	s	Gal	dyn	dyn/cm ²	dyn/cm ²	erg
Gravitation system	m	kgf · s ² /m	s	m/s ²	kgf	kgf/m ²	kgf/m ²	kgf · m

Conversion to SI unit

Quantity	Unit designation	Symbol	Conversion rate to SI	SI unit designation	Symbol
Angle	Degree	°	$\pi/180$	Radian	rad
	Minute	'	$\pi/10\ 800$		
	Second	" (sec)	$\pi/648\ 000$		
Length	Meter	m	1	Meter	m
	Micron	μ	10^{-6}		
	Angstrom	Å	10^{-10}		
Area	Square meter	m ²	1	Square meter	m ²
	Are	a	10^2		
	Hector	ha	10^4		
Volume	Cubic meter	m ³	1	Cubic meter	m ³
	Liter	R.L	10^{-3}		
Mass	kilogram	kg	1	Kilogram	kg
	Ton	t	10^3		
	Weight kilogram.square second per meter	kgf · s ² /m	9.806 65		
Time	Second	s	1	Second	s
	Minute	min	60		
	Hour	h	3 600		
	Day	d	86 400		
Speed	Meter per second	m/s	1	Meter per second	m/s
	Knot	kn	1 852/3 600		
Frequency and vibration	Cycle	s ⁻¹ (pps)	1	Hertz	Hz
Revolutions (rotational speed)	Revolutions per minute per second	rpm (r/min)	1/60	Per second	s ⁻¹
Angular speed	Radian per second	rad/s	1	Radian per second	rad/s
Acceleration	Meter per second per second	m/s ²	1	Meter per second per second	m/s ²
	G	G	9.806 65		
Force	Weight kilogram	kgf	9.806 65	Newton	N
	Weight ton	tf	9 806.65		
	Dyne	dyn	10^{-5}		
Force moment	Weight kilogram meter	kgf · m	9.806 65	Newton meter	N · m
Inertia moment	Weight kilogram per square meter	kgf · m · s ²	9.806 65	kilogram square meter	kg · m ²
Stress	Weight kilogram per square meter	kgf/m ²	9.806 65	Pascal or Newton per square meter	Pa or N/m ²
Pressure	Weight kilogram per square meter	kgf/m ²	9.806 65	Pascal	Pa
	Water column meter	mH ₂ O	9 806.65		
	Mercury column meter	mHg	101 325/0.76		
	Torr	Torr	101 325/760		
	Atmospheric pressure	atm	101 325		
	Bar	bar	10^5		
Energy	Erg	erg	10^{-7}	Joule	J
	IT calorie	cal _{IT}	4.186 8		
	Weight kilogram meter	kgf · m	9.806 65		
	Kilowatt per hour	kW · h	3.600×10^6		
Horse power per hour	PS · h	$2.647\ 79 \times 10^6$			
Power rate and power	Watt	W	1	Watt	W
	Horse power	PS	735.5		
	Weight kilogram meter per second	kgf · m/s	9.806 65		

Unit system	Quantity	Power rate	Temperature	Viscosity	Dynamic viscosity	Magnetic flux	Flux density	Magnetic field strength
SI		W	K	Pa · s	m ² /s	Wb	T	A/m
CGS system		erg/s	°C	P	St	Mx	Gs	Oe
Gravitation system		kgf · m/s	°C	kgf · s/m ²	m ² /s	—	—	—

Conversion to SI unit

Quantity	Unit designation	Symbol	Conversion rate to SI	SI unit designation	Symbol
Viscosity	Poise	P	10 ⁻¹	Pascal second	Pa · s
	Centi poise	cP	10 ⁻³		
	Weight kilogram second per square meter	kgf · s/m ²	9.806 65		
Dynamic viscosity	Stokes	St	10 ⁻⁴	Square meter per second	m ² /s
	Centistokes	cSt	10 ⁻⁶		
Temperature	Degree	°C	+273.15	Kelvin	K
Radioactive Dosage	Curie	Ci	3.7 × 10 ¹⁰	Becquere	Bq
	Roentgen	R	2.58 × 10 ⁻⁴	Coulomb per kilogram	C/kg
Absorption dosage	Rad	rad	10 ⁻²	Gray	Gy
Dosage equivalent	Rem	rem	10 ⁻²	Sivert	Sv
Magnetic flux	Maxwell	Mx	10 ⁻⁸	Weber	Wb
Flux density	Gamma	γ	10 ⁻⁹	Tesler	T
	Gauss	Gs	10 ⁻⁴		
Magnetic field strength	Oersted	Oe	10 ³ /4π	Ampere per meter	A/m
Quantity of electricity	Coulomb	C	1	Coulomb	C
Potential difference	Volt	V	1	Volt	V
Electric resistance	Ohm	Ω	1	Ohm	Ω
Current	Ampere	A	1	Ampere	A

Integer multiplication of SI unit 10

Unit × multiple	Initial letter	
	Name	Symbol
10 ¹⁸	Exa	E
10 ¹⁵	Peta	P
10 ¹²	Tera	T
10 ⁹	Guiga	G
10 ⁶	Mega	M
10 ³	Kilo	k
10 ²	Hect	h
10	Daca	da
10 ⁻¹	Deci	d
10 ⁻²	Centi	c
10 ⁻³	Mili	m
10 ⁻⁶	Micro	μ
10 ⁻⁹	Nano	n
10 ⁻¹²	Pico	p
10 ⁻¹⁵	Femt	f
10 ⁻¹⁸	Atto	a

kgf-N conversion table

kgf		N	kgf		N	kgf		N
0.1020	1	9.8066	3.4670	34	333.43	6.8321	67	657.04
0.2039	2	19.613	3.5690	35	343.23	6.9341	68	666.85
0.3059	3	29.420	3.6710	36	353.04	7.0361	69	676.66
0.4079	4	39.227	3.7730	37	362.85	7.1380	70	686.46
0.5099	5	49.033	3.8749	38	372.65	7.2400	71	696.27
0.6118	6	58.840	3.9769	39	382.46	7.3420	72	706.08
0.7138	7	68.646	4.0789	40	392.27	7.4440	73	715.88
0.8158	8	78.453	4.1808	41	402.07	7.5459	74	725.69
0.9177	9	88.260	4.2828	42	411.88	7.6479	75	735.50
1.0197	10	98.066	4.3848	43	421.68	7.7499	76	745.30
1.1217	11	107.87	4.4868	44	431.49	7.8518	77	755.11
1.2237	12	117.68	4.5887	45	441.30	7.9538	78	764.92
1.3256	13	127.49	4.6907	46	451.10	8.0558	79	774.72
1.4276	14	137.29	4.7927	47	460.91	8.1578	80	784.53
1.5296	15	147.10	4.8946	48	470.72	8.2597	81	794.34
1.6316	16	156.91	4.9966	49	480.52	8.3617	82	804.14
1.7335	17	166.71	5.0986	50	490.33	8.4637	83	813.95
1.8355	18	176.52	5.2006	51	500.14	8.5656	84	823.76
1.9375	19	186.33	5.3025	52	509.94	8.6676	85	833.56
2.0394	20	196.13	5.4045	53	519.75	8.7696	86	843.37
2.1414	21	205.94	5.5065	54	529.56	8.8716	87	853.18
2.2434	22	215.75	5.6085	55	539.36	8.9735	88	862.98
2.3454	23	225.55	5.7104	56	549.17	9.0755	89	872.79
2.4473	24	235.36	5.8124	57	558.98	9.1775	90	882.60
2.5493	25	245.17	5.9144	58	568.78	9.2794	91	892.40
2.6513	26	254.97	6.0163	59	578.59	9.3814	92	902.21
2.7532	27	264.78	6.1183	60	588.40	9.4834	93	912.02
2.8552	28	274.59	6.2203	61	598.20	9.5854	94	921.82
2.9572	29	284.39	6.3223	62	608.01	9.6873	95	931.63
3.0592	30	294.20	6.4242	63	617.82	9.7893	96	941.44
3.1611	31	304.01	6.5262	64	627.62	9.8913	97	951.24
3.2631	32	313.81	6.6282	65	637.43	9.9932	98	961.05
3.3651	33	323.62	6.7302	66	647.24	10.0952	99	970.86

[How to read the table]

For example, for conversion from 10kgf to N read 10 on center stage of 1st row box and then read the right-side N. 10kgf is equivalent to 98.066 upon reading. Furthermore, for conversion from 10N to kgf read the right side kgf box. 10N is equivalent to 1.0197kg upon reading.

1kgf=9.80665N
1N=0.101972kgf

Viscosity conversion table

Dynamic viscosity mm ² /s	Saybolt SUS (sec)	Redwood R" (sec)	Engler E (deg.)
2.7	35	32.2	1.18
4.3	40	36.2	1.32
5.9	45	40.6	1.46
7.4	50	44.9	1.60
8.9	55	49.1	1.75
10.4	60	53.5	1.88
11.8	65	57.9	2.02
13.1	70	62.3	2.15
14.5	75	67.6	2.31
15.8	80	71.0	2.42
17.0	85	75.1	2.55
18.2	90	79.6	2.68
19.4	95	84.2	2.81
20.6	100	88.4	2.95
23.0	110	97.1	3.21
25.0	120	105.9	3.49
27.5	130	114.8	3.77
29.8	140	123.6	4.04
32.1	150	132.4	4.32
34.3	160	141.1	4.59
36.5	170	150.0	4.88
38.8	180	158.8	5.15
41.0	190	167.5	5.44
43.2	200	176.4	5.72
47.5	220	194.0	6.28
51.9	240	212	6.85
56.5	260	229	7.38
60.5	280	247	7.95
64.9	300	265	8.51
70.3	325	287	9.24
75.8	350	309	9.95
81.2	375	331	10.7
86.8	400	353	11.4
92.0	425	375	12.1
97.4	450	397	12.8

Dynamic viscosity mm ² /s	Saybolt SUS (sec)	Redwood R" (sec)	Engler E (deg.)
103	475	419	13.5
108	500	441	14.2
119	550	485	15.6
130	600	529	17.0
141	650	573	18.5
152	700	617	19.9
163	750	661	21.3
173	800	705	22.7
184	850	749	24.2
195	900	793	25.6
206	950	837	27.0
217	1 000	882	28.4
260	1 200	1 058	34.1
302	1 400	1 234	39.8
347	1 600	1 411	45.5
390	1 800	1 587	51
433	2 000	1 763	57
542	2 500	2 204	71
650	3 000	2 646	85
758	3 500	3 087	99
867	4 000	3 526	114
974	4 500	3 967	128
1 082	5 000	4 408	142
1 150	5 500	4 849	156
1 300	6 000	5 290	170
1 400	6 500	5 730	185
1 510	7 000	6 171	199
1 630	7 500	6 612	213
1 740	8 000	7 053	227
1 850	8 500	7 494	242
1 960	9 000	7 934	256
2 070	9 500	8 375	270
2 200	10 000	8 816	284

Ordinary tolerance for cutting dimensions

JIS B 0405

Ordinary tolerance is applied to cutting dimensions for which special accuracy is not required functionally and, therefore, applicable tolerances are indicated in batch, without individual indication of them, in relevant specification, drawings, etc.

Ordinary tolerances shall be indicated by either one of the following methods (1) and (2).

- (1) Numerical value table for each dimensional division
- (2) Applicable Standard No. and tolerance class

Ex. Ordinary tolerance shall conform to the "Medium Class" specified in JIS B 0405.

Unit : mm

Dimensional division	Class	Tolerance				
		Fine class (Class-12)	Medium class (Class-14)	Coarse class (Class-16)		
0.5 and over 3 incl. Over 3 6 incl.		±0.05	±0.1	—		
				±0.2		
Over 6 30 incl. Over 30 120 incl. Over 120 315 incl.		±0.1	±0.2	±0.5		
				±0.15	±0.3	±0.8
				±0.2	±0.5	±1.2
Over 315 1000 incl. Over 1000 2000 incl.		±0.3	±0.8	±2		
				±0.5	±1.2	±3

Reference: The numerical values given above every each of "Fine Class", "Medium class" and "Coarse Class" match "Fine series, Medium series", and Coarse series" specified in ISO 2768 (Permissible Machining Variations in Dimensions without Tolerance

Ordinary tolerances for castings

JIS B 0407

This Standard specifies the ordinary tolerances for the as-casted length and wall thickness dimensions (hereinafter referred to as "ordinary tolerance") of gray castings and spherical graphite

castings molded using sand molds (excluding precision mold and other equivalent).

The ordinary tolerance shall be indicated by either one of the following methods (1) and (2).

- (1) Numerical value table for each dimensional division
- (2) Applicable Standard No. and tolerance class

Ex. JIS B 0407, Coarse class

Ordinary tolerance for length

Unit : mm

Dimensional division	Material Class	Gray castings		Spherical graphite castings	
		Fine class	Coarse class	Fine class	Coarse class
120 incl.		±1	± 1.5	±1.5	± 2
Over 120 250 incl.		±1.5	± 2	±2	± 2.5
Over 250 400 incl.		±2	± 3	±2.5	± 3.5
Over 400 800 incl.		±3	± 4	±4	± 5
Over 800 1600 incl.		±4	± 6	±5	± 7
Over 1600 3150 incl.		—	±10	—	±10

Ordinary tolerance for wall thickness

Unit : mm

Dimensional division	Material Class	Gray castings		Spherical graphite castings	
		Fine class	Coarse class	Fine class	Coarse class
10 incl.		±1	±1.5	±1.2	±2
Over 10 18 incl.		±1.5	±2	±1.5	±2.5
Over 18 30 incl.		±2	±3	±2	±3
Over 30 50 incl.		±2	±3.5	±2.5	±4

Dimension-A for draft angle

Unit : mm

Dimensional division	Dimension A (max)
18 incl.	1
Over 18 30 incl.	1.5
Over 30 50 incl.	2
Over 50 120 incl.	2.5
Over 120 315 incl.	3.5
Over 315 630 incl.	6
Over 630 1000 incl.	9

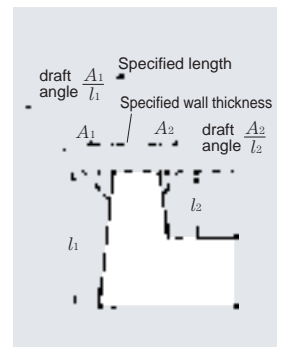

Remarks : l means l₁ and l₂ in the above sketch.
A means A₁, A₂ in the above sketch.

Ordinary tolerances for press-formed metal parts

JIS B 0408

This Standard specifies the ordinary tolerances for the punching, bending and drawing dimensions, bending angle of press-formed metal parts (hereinafter referred to as "ordinary tolerance").

Ordinary tolerance is applied to the dimensions for which special accuracy is not required functionally and, therefore, applicable tolerances are indicated in batch, without individual indication of them, in relevant specification, drawings, etc.

Ordinary tolerance shall be indicated by either one of the following methods (1) and (2).

- (1) Numerical value table for each dimensional division
- (2) Applicable Standard No. and tolerance class

Ex. JIS B0408, Class-A

Ordinary tolerance for punching, bending and drawing dimensions

Unit : mm

Dimensional division	Class				
	Class-A	Class-B	Class-C	Class-D	Class-E
30 incl.	±0.1	±0.15	±0.25	±0.4	±0.6
Over 30 120 incl.	±0.15	±0.25	±0.45	±0.7	±1.1
Over 120 315 incl.	±0.2	±0.4	±0.6	±1	±1.6
Over 315 1000 incl.	±0.3	±0.7	±1.1	±1.8	±2.8
Over 1000 2000 incl.	±0.5	±1.1	±1.8	±3	±4.5

Ordinary tolerance for bending angle

Unit : degree

Type of bending	Class	
	Class B, C	Class D, E
Perpendicular bending	±1	±2
Other bending	±1.5	±3

Remarks: The ordinary tolerance for bending angle shall be applied to Class-A tolerance.

Ordinary tolerance for die casts

JIS B 0409

This Standard specifies the ordinary tolerance for the as-casted dimensions of zinc alloy die casts and aluminum alloy die casts.

The ordinary tolerance shall be indicated by either one of the following methods (1) and (2).

- (1) Numerical value table for each dimensional division
- (2) Applicable standard No. Ex.:JIS B 0409

Ordinary tolerance for dimensions

Unit : mm

Dimensional division	Classification by application	Portions casted by solid die and movable die		Portions casted by movable core		
		Parallel to die split surface	Perpendicular to die split surface ¹⁾ l_2		l_2	
			Projected area of castings perpendicular to die split surface ²⁾ cm^2		Projected area of casting portion perpendicular to moving direction of movable core cm^2	
			600 and below	over 600 2400 incl.	150 and below	over 150 600 incl.
30 incl.	±0.25	±0.5	±0.6	±0.5	±0.6	
Over 30 50 incl.	±0.3	±0.5	±0.6	±0.5	±0.6	
Over 50 80 incl.	±0.35	±0.6	±0.6	±0.6	±0.6	
Over 80 120 incl.	±0.45	±0.7	±0.7	±0.7	±0.7	
Over 120 180 incl.	±0.5	±0.8	±0.8	±0.8	±0.8	
Over 180 250 incl.	±0.55	±0.9	±0.9	±0.9	±0.9	
Over 250 315 incl.	±0.6	±1	±1	±1	±1	
Over 315 400 incl.	±0.7	—	—	—	—	
Over 400 500 incl.	±0.8	—	—	—	—	
Over 500 630 incl.	±0.9	—	—	—	—	
Over 630 800 incl.	±1	—	—	—	—	
Over 800 1000 incl.	±1.1	—	—	—	—	

Note 1) The dimensional tolerance for l_1 shall be applied to partial dimension of die split surface which does not influence the length.

2) "Projected area of castings" means the circumference internal projected area of as-casted castings.

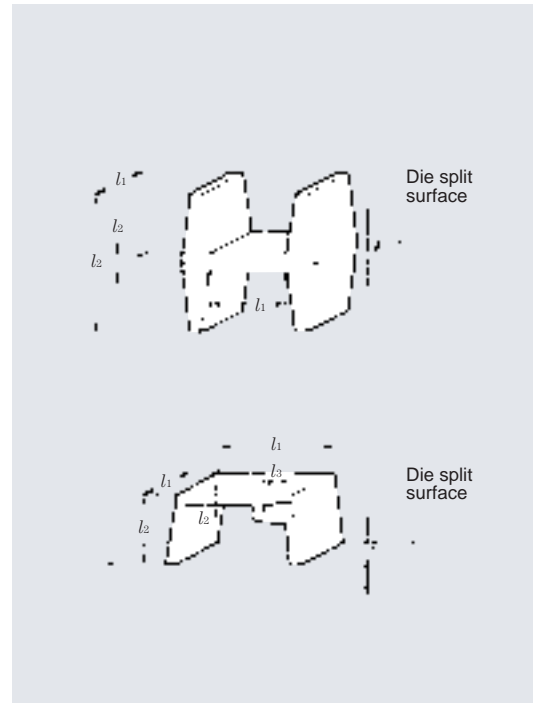

Maximum draft angle value

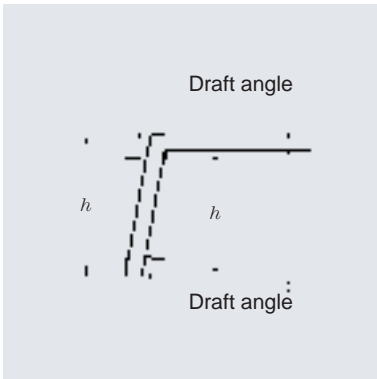

Unit : degree

Length of draft portion(mm)	Material	
	Aluminum alloy	Zinc alloy
3 and less	10	6
Over 3 - 10 incl.	5	3
Over 10 - 50 incl.	3	2
Over 50 - 315 incl.	2	1.5

Chart showing the relationship of drafted portion length (h) vs draft angle dimension (σ)

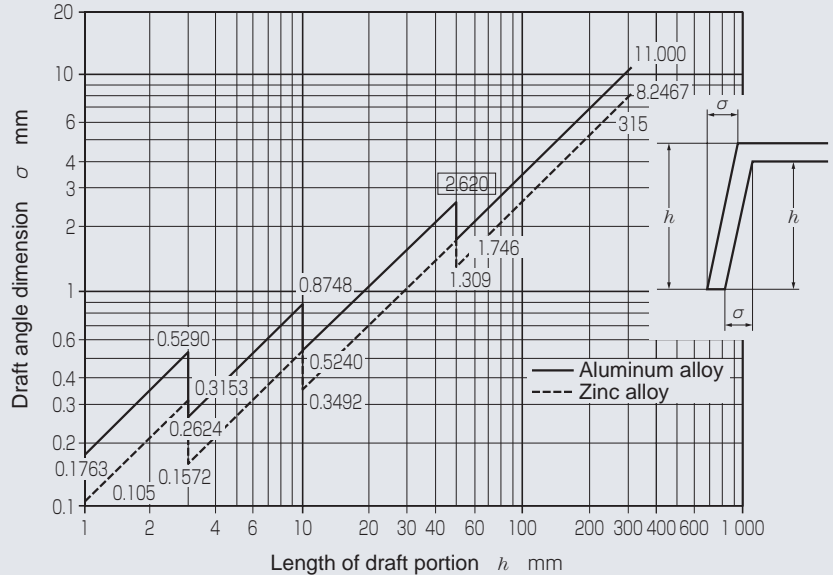

Ordinary tolerances for sheared metal plates

JIS B 0410

This Standard specifies the ordinary tolerances for the shearing width and ordinary tolerances for the straightness and perpendicularity (hereinafter generically referred to as "ordinary tolerance") of metal plates of 12mm and less in thickness which were sheared by direct shearing machines such as gear pusher, square shear, etc.

The ordinary tolerance shall be indicated by either one of the following methods (1) and (2).

- (1) Numerical value table for each dimensional division
- (2) Applicable standard No. and tolerance class

Ex. 1. JIS B 0410, Class-B

- 2. Cutting width, straightness: JIS B 0410, Class-B
- Perpendicularity: JIS B 0410, Class-A

Definition of the terms: The terms used in this Standard are as defined in JIS B 0111 (Terminology relating to press machines) and, in addition, defined as follows.

- (1) Cutting width: Distance from one side sheared by shear cutter to opposite side, as illustrated in Fig. *b*
- (2) Cutting length: length of one side sheared by shear cutter, as illustrated in Fig. *l*.

Ordinary tolerance for shearing width

Unit : mm

Classification by plate thickness Cutting width division	1.6 and less		Over 1.6 3 incl.		Over 3 6 incl.		Over 6 12 incl.	
	Class-A	Class-B	Class-A	Class-B	Class-A	Class-B	Class-A	Class-B
120 and less	±0.2	±0.5	±0.3	±0.5	±0.7	±1.2	—	±1.6
Over 120 - 315 incl.	±0.3	±0.6	±0.4	±0.8	±0.9	±1.6	—	±2.0
Over 315 - 1000 incl.	±0.5	±1.0	±0.5	±1.2	±1.6	±2.0	—	±2.5
Over 1000 - 2000 incl.	±0.8	±1.2	±0.8	±1.6	±2.0	±3.0	—	±3.0
Over 2000 - 3150 incl.	±1.0	±1.4	±1.0	±1.6	±2.8	±3.0	—	±3.5

Remarks: non-applicable to cutting length exceeding 3150 mm.

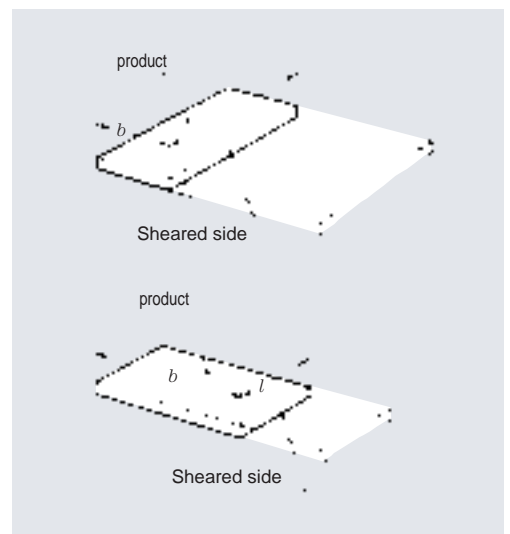

Ordinary tolerance for straightness Unit : mm

Classification by plate thickness Cutting width division	1.6 and less		Over 1.6 3 incl.		Over 3 6 incl.	
	Class-A	Class-B	Class-A	Class-B	Class-A	Class-B
120 and less	0.2	0.3	0.2	0.3	0.5	0.8
Over 120 - 315 incl.	0.3	0.5	0.3	0.6	1.0	1.6
Over 315 - 1000 incl.	0.4	0.9	0.5	1.0	1.4	2.0
Over 1000 - 2000 incl.	0.6	1.2	0.8	1.6	2.5	3.0
Over 2000 - 3150 incl.	0.9	1.6	1.0	2.2	2.8	4.5

Remarks: Non-applicable to cutting width of less than 20 times as much as plate thickness or cutting width of less than 30mm.

Ordinary tolerance for straightness Unit : mm

Classification by plate thickness Cutting width division	3 and less		Over 3 6 incl.		Over 6 12 incl.	
	Class-A	Class-B	Class-A	Class-B	Class-A	Class-B
120 and less	0.3	0.5	0.5	1.0	—	1.6
Over 120 - 315 incl.	0.6	1.2	0.8	1.6	—	2.0
Over 315 - 1000 incl.	1.6	3.0	2.0	3.0	—	3.0
Over 1000 - 2000 incl.	3.0	6.0	4.0	6.0	—	6.0
Over 2000 - 3150 incl.	4.5	9.0	5.5	9.0	—	9.0

Ordinary tolerance for sintered metal parts

JIS B 0411

This Standard specifies the ordinary tolerance which is applied to the machining dimensions of sintered mechanical parts and sintered oil-contained bearing, of sintered metal parts, but excluding machining methods other (e.g. cutting, etc.) than the machining method specific for sintered metal parts.

Ordinary tolerance is applied to the dimensions for which special accuracy is not required functionally and, therefore, applicable tolerances are indicated in batch, without individual indication of them, in relevant specification, drawings, etc.

Ordinary tolerance shall be indicated by either one of the following methods (1) and (2).

- (1) Numerical value table for each dimensional division
- (2) Applicable Standard No. and tolerance class
Ex. JIS B0411, Fine Class

Definition of terms: The terms used in this Standard are as defined below.

- (1) Width: Perpendicular dimension against compressing direction in compressive molding of powders, as illustrated in Fig. *a*.
- (2) Height: Dimension parallel to compressing direction in molding of powders, as illustrated in Fig. *b*.

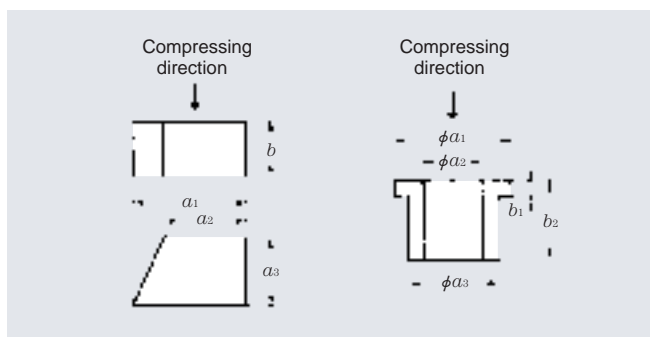

Class: The ordinary tolerance class shall be three classes of "Fine Class", "Medium Class" and "Coarse class".

Reference: The numerical values every each class of "Fine Class", "Medium Class" and "Coarse class" match "Fine Series, Medium Series and Coarse Series specified in ISO 2768 (Permissible machining variations in dimensions without tolerance indication)

Ordinary tolerance for width Unit : mm

Dimensional division	class		
	Fine class	Medium class	Coarse class
6 and less	±0.05	±0.1	±0.2
Over 6 - 30 incl.	±0.1	±0.2	±0.5
Over 30 - 120 incl.	±0.15	±0.3	±0.8
Over 120 - 315 incl.	±0.2	±0.5	±1.2

Ordinary tolerance for height Unit : mm

Dimensional division	class		
	Fine class	Medium class	Coarse class
6 and less	±0.1	±0.2	±0.6
Over 6 - 30 incl.	±0.2	±0.5	±1
Over 30 - 120 incl.	±0.3	±0.8	±1.8

Ordinary tolerance for steel castings

JIS B 0412

This Standard specifies the ordinary tolerances for the length and as-casted wall thickness (hereinafter referred to as "ordinary tolerance") of steel castings casted by sand molds.

Ordinary tolerance shall be indicated by either one of the following methods (1) and (2).

- (1) Numerical value table for each dimensional division
 - (2) Applicable Standard No. and tolerance class
- Ex. JIS B0412, Medium Class

Tolerance class: The ordinary tolerance class shall be three classes of "Fine Class", "Medium Class" and "Coarse Class".

Ordinary tolerance for length

Unit : mm

Dimensional division \ class	Fine class	Medium class	Coarse class
120 and less	±1.8	± 2.8	± 4.5
Over 120 - 315 incl.	±2.5	± 4	± 6
Over 315 - 630 incl.	±3.5	± 5.5	± 9
Over 630 - 1250 incl.	±5	± 8	±12
Over 1250 - 2500 incl.	±9	±14	±22
Over 2500 - 5000 incl.	—	±20	±35
Over 5000 - 10000 incl.	—	—	±63

Ordinary tolerance for wall thickness

Unit : mm

Dimensional division \ class	Fine class	Medium class	Coarse class
18 and less	±1.4	±2.2	± 3.5
Over 18 - 50 incl.	±2	±3	± 5
Over 50 - 120 incl.	—	±4.5	± 7
Over 120 - 250 incl.	—	±5.5	± 9
Over 250 - 400 incl.	—	±7	±11
Over 400 - 630 incl.	—	±9	±14
Over 630 - 1000 incl.	—	—	±18

Remarks: "Fine Class" shall be applied to minor steel castings subjected to special accuracy.

Dimension-A for draft angle

Unit : mm

Dimensional division <i>l</i>	Dimension A (max)
18 incl.	1.4
Over 18 50 incl.	2
Over 50 120 incl.	2.8
Over 120 250 incl.	3.5
Over 250 400 incl.	4.5
Over 400 630 incl.	5.5
Over 630 1000 incl.	7

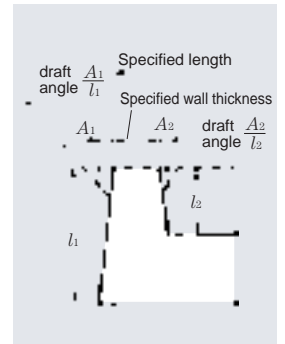

Remarks: *l* means *l*₁ and *l*₂ in the above sketch.
A means *A*₁, *A*₂ in the above sketch.

Ordinary tolerance for aluminum alloy castings

JIS B 0414

This Standard specifies the ordinary tolerances (hereinafter referred to as "ordinary tolerance") for the length and wall thickness of aluminum alloy castings (hereinafter referred to as "castings" molded by sand mold and mold. However, this Standard is not applied to castings molded by precision molds using "Lost Wax Method", etc.

Ordinary tolerance shall be indicated by either one of the following methods (1) and (2).

- (1) Numerical value table for each dimensional division
- (2) Applicable Standard No. , classification and tolerance class by casting mold

Ex. JIS 0414 , Sand mold, Coarse Class

Definition of terms: The terms used in this Standard are as defined below.

Mold split surface: Two or more splitted surfaces of mold for drafting a model or a castings out of a casting mold.

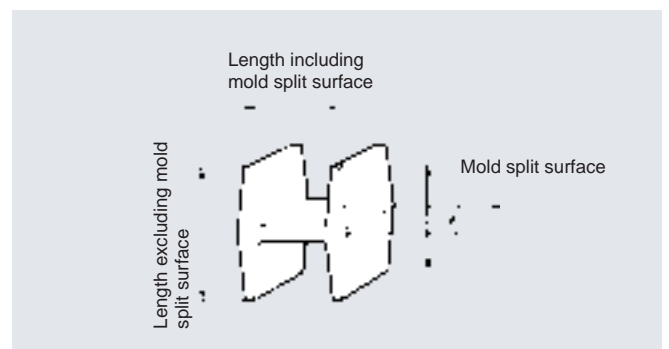

Ordinary tolerance for length

Unit : mm

Type	Dimensional division	50 incl.		Over 50 120 incl.		Over 120 250 incl.		Over 250 400 incl.		Over 400 800 incl.		Over 800 1600 incl.		Over 1600 3150 incl.		(Ref.) ¹⁾ Correspond to standard tolerance grade	
		class	Fine class	Coarse class	Fine class	Coarse class	Fine class	Coarse class	Fine class	Coarse class	Fine class	Coarse class	Fine class	Coarse class	Fine class	Coarse class	Fine class
Castings by sand mold	Portion including no mold split surface	±0.5	±1.1	±0.7	±1.2	±0.9	±1.4	±1.1	±1.8	±1.6	±2.5	—	±4	—	±7	15	16
	Portion including mold split surface	±0.8	±1.5	±1.1	±1.8	±1.4	±2.2	±1.8	±2.8	±2.5	±4.0	—	±6	—	—	16	17
Castings by casting mold	Portion including no mold split surface	±0.3	±0.5	±0.45	±0.7	±0.55	±0.9	±0.7	±1.1	±1.0	±1.6	—	—	—	—	14	15
	Portion including mold split surface	±0.5	±0.6	±0.7	±0.8	±0.9	±1.0	±1.1	±1.2	±1.6	±1.8	—	—	—	—	15	15

Note 1) Conforming to Appendix-2 to JIS B 0404 (Rule for Ordinary Dimensional Tolerances)

Ordinary tolerance for wall thickness

Unit : mm

Type	Dimensional division Max. length of castings	6 incl.		Over 6 10 incl.		Over 10 18 incl.		Over 18 30 incl.		Over 30 50 incl.	
		Fine class	Coarse class	Fine class	Coarse class	Fine class	Coarse class	Fine class	Coarse class	Fine class	Coarse class
Castings by sand mold	120 incl.	±0.6	±1.2	±0.7	±1.4	±0.8	±1.6	±0.9	±1.8	—	—
	Over 120 250 incl.	±0.7	±1.3	±0.8	±1.5	±0.9	±1.7	±1.0	±1.9	±1.2	±2.3
	Over 250 400 incl.	±0.8	±1.4	±0.9	±1.6	±1.0	±1.8	±1.1	±2.0	±1.3	±2.4
	Over 400 800 incl.	±1.0	±1.6	±1.1	±1.8	±1.2	±2.0	±1.3	±2.2	±1.5	±2.6
Castings by casting mold	120 incl.	±0.3	±0.7	±0.4	±0.9	±0.5	±1.1	±0.6	±1.3	—	—
	Over 120 250 incl.	±0.4	±0.8	±0.5	±1.0	±0.6	±1.2	±0.7	±1.4	±0.9	±1.8
	Over 250 400 incl.	±0.5	±0.9	±0.6	±1.1	±0.7	±1.3	±0.8	±1.5	±1.0	±1.9

Maximum draft angle value

Unit : degree

Classification by draft angle	Outer		Inner	
	Fine class	Coarse class	Fine class	Coarse class
Type of castings				
Fine class	1	2	2	3
Coarse class				

Remarks: The numerical values in this table shall be applied to draft portions of 400 mm and less in length.

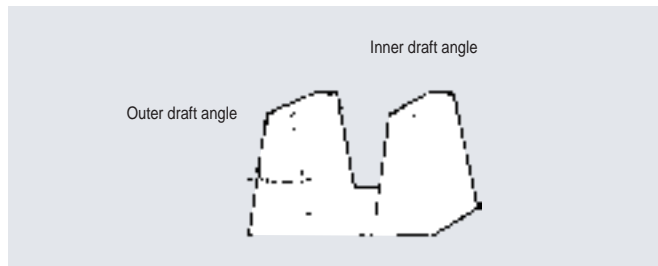

Dimensional tolerance for shaft

Diameter division mm		a13		c12		d6		e6		e13		f5		f6		g5		g6	
Over	incl.	High	Low	High	Low	High	Low	High	Low	High	Low	High	Low	High	Low	High	Low	High	Low
3	6	-270	-450	-70	-190	-30	-38	-20	-28	-20	-200	-10	-15	-10	-18	-4	-9	-4	-12
6	10	-280	-500	-80	-230	-40	-49	-25	-34	-25	-245	-13	-19	-13	-22	-5	-11	-5	-14
10	18	-290	-560	-95	-275	-50	-61	-32	-43	-32	-302	-16	-24	-16	-27	-6	-14	-6	-17
18	30	-300	-630	-110	-320	-65	-78	-40	-53	-40	-370	-20	-29	-20	-33	-7	-16	-7	-20
30	40	-310	-700	-120	-370	-80	-96	-50	-66	-50	-440	-25	-36	-25	-41	-9	-20	-9	-25
40	50	-320	-710	-130	-380														
50	65	-340	-800	-140	-440	-100	-119	-60	-79	-60	-520	-30	-43	-30	-49	-10	-23	-10	-29
65	80	-360	-820	-150	-450														
80	100	-380	-920	-170	-520	-120	-142	-72	-94	-72	-612	-36	-51	-36	-58	-12	-27	-12	-34
100	120	-410	-950	-180	-530														
120	140	-460	-1 090	-200	-600														
140	160	-520	-1 150	-210	-610	-145	-170	-85	-110	-85	-715	-43	-61	-43	-68	-14	-32	-14	-39
160	180	-580	-1 210	-230	-630														
180	200	-660	-1 380	-240	-700														
200	225	-740	-1 460	-260	-720	-170	-199	-100	-129	-100	-820	-50	-70	-50	-79	-15	-35	-15	-44
225	250	-820	-1 540	-280	-740														
250	280	-920	-1 730	-300	-820	-190	-222	-110	-142	-110	-920	-56	-79	-56	-88	-17	-40	-17	-49
280	315	-1 050	-1 860	-330	-850														
315	355	-1 200	-2 090	-360	-930	-210	-246	-125	-161	-125	-1 015	-62	-87	-62	-98	-18	-43	-18	-54
355	400	-1 350	-2 240	-400	-970														
400	450	-1 500	-2 470	-440	-1 070	-230	-270	-135	-175	-135	-1 105	-68	-95	-68	-108	-20	-47	-20	-60
450	500	-1 650	-2 620	-480	-1 110														
500	560	-	-	-	-	-260	-304	-145	-189	-	-	-	-	-76	-120	-	-	-22	-66
560	630																		
630	710	-	-	-	-	-290	-340	-160	-210	-	-	-	-	-80	-130	-	-	-24	-74
710	800																		
800	900	-	-	-	-	-320	-376	-170	-226	-	-	-	-	-86	-142	-	-	-26	-82
900	1 000																		
1 000	1 120	-	-	-	-	-350	-416	-195	-261	-	-	-	-	-98	-164	-	-	-28	-94
1 120	1 250																		
1 250	1 400	-	-	-	-	-390	-468	-220	-298	-	-	-	-	-110	-188	-	-	-30	-108
1 400	1 600																		

Diameter division mm		j5		js5		j6		js6		j7		k4		k5		k6		m5	
Over	incl.	High	Low	High	Low	High	Low	High	Low	High	Low	High	Low	High	Low	High	Low	High	Low
3	6	+3	-2	+2.5	-2.5	+6	-2	+4	-4	+8	-4	+5	+1	+6	+1	+9	+1	+9	+4
6	10	+4	-2	+3	-3	+7	-2	+4.5	-4.5	+10	-5	+5	+1	+7	+1	+10	+1	+12	+6
10	18	+5	-3	+4	-4	+8	-3	+5.5	-5.5	+12	-6	+6	+1	+9	+1	+12	+1	+15	+7
18	30	+5	-4	+4.5	-4.5	+9	-4	+6.5	-6.5	+13	-8	+8	+2	+11	+2	+15	+2	+17	+8
30	40																		
40	50	+6	-5	+5.5	-5.5	+11	-5	+8	-8	+15	-10	+9	+2	+13	+2	+18	+2	+20	+9
50	65																		
65	80	+6	-7	+6.5	-6.5	+12	-7	+9.5	-9.5	+18	-12	+10	+2	+15	+2	+21	+2	+24	+11
80	100																		
100	120	+6	-9	+7.5	-7.5	+13	-9	+11	-11	+20	-15	+13	+3	+18	+3	+25	+3	+28	+13
120	140																		
140	160	+7	-11	+9	-9	+14	-11	+12.5	-12.5	+22	-18	+15	+3	+21	+3	+28	+3	+33	+15
160	180																		
180	200																		
200	225	+7	-13	+10	-10	+16	-13	+14.5	-14.5	+25	-21	+18	+4	+24	+4	+33	+4	+37	+17
225	250																		
250	280	+7	-16	+11.5	-11.5	+16	-16	+16	-16	+26	-26	+20	+4	+27	+4	+36	+4	+43	+20
280	315																		
315	355	+7	-18	+12.5	-12.5	+18	-18	+18	-18	+29	-28	+22	+4	+29	+4	+40	+4	+46	+21
355	400																		
400	450	+7	-20	+13.5	-13.5	+20	-20	+20	-20	+31	-32	+25	+5	+32	+5	+45	+5	+50	+23
450	500																		
500	560	-	-	-	-	-	-	+22	-22	-	-	-	-	-	-	+44	0	-	-
560	630																		
630	710	-	-	-	-	-	-	+25	-25	-	-	-	-	-	-	+50	0	-	-
710	800																		
800	900	-	-	-	-	-	-	+28	-28	-	-	-	-	-	-	+56	0	-	-
900	1 000																		
1 000	1 120	-	-	-	-	-	-	+33	-33	-	-	-	-	-	-	+66	0	-	-
1 120	1 250																		
1 250	1 400	-	-	-	-	-	-	+39	-39	-	-	-	-	-	-	+78	0	-	-
1 400	1 600																		

Unit : μm

h4		h5		h6		h7		h8		h9		h10		h11		h13		js4		Diameter division mm	
High	Low	High	Low	High	Low	High	Low	High	Low	High	Low	High	Low	High	Low	High	Low	High	Low	Over	incl.
0	-4	0	-5	0	-8	0	-12	0	-18	0	-30	0	-48	0	-75	0	-180	+2	-2	3	6
0	-4	0	-6	0	-9	0	-15	0	-22	0	-36	0	-58	0	-90	0	-220	+2	-2	6	10
0	-5	0	-8	0	-11	0	-18	0	-27	0	-43	0	-70	0	-110	0	-270	+2.5	-2.5	10	18
0	-6	0	-9	0	-13	0	-21	0	-33	0	-52	0	-84	0	-130	0	-330	+3	-3	18	30
0	-7	0	-11	0	-16	0	-25	0	-39	0	-62	0	-100	0	-160	0	-390	+3.5	-3.5	30	40
																				40	50
0	-8	0	-13	0	-19	0	-30	0	-46	0	-74	0	-120	0	-190	0	-460	+4	-4	50	65
																				65	80
0	-10	0	-15	0	-22	0	-35	0	-54	0	-87	0	-140	0	-220	0	-540	+5	-5	80	100
																				100	120
0	-12	0	-18	0	-25	0	-40	0	-63	0	-100	0	-160	0	-250	0	-630	+6	-6	120	140
																				140	160
																				160	180
0	-14	0	-20	0	-29	0	-46	0	-72	0	-115	0	-185	0	-290	0	-720	+7	-7	180	200
																				200	225
																				225	250
0	-16	0	-23	0	-32	0	-52	0	-81	0	-130	0	-210	0	-320	0	-810	+8	-8	250	280
																				280	315
0	-18	0	-25	0	-36	0	-57	0	-89	0	-140	0	-230	0	-360	0	-890	+9	-9	315	355
																				355	400
0	-20	0	-27	0	-40	0	-63	0	-97	0	-155	0	-250	0	-400	0	-970	+10	-10	400	450
																				450	500
-	-	-	-	0	-44	0	-70	0	-110	0	-175	0	-280	0	-440	0	-	-	-	500	560
																				560	630
-	-	-	-	0	-50	0	-80	0	-125	0	-200	0	-320	0	-500	0	-	-	-	630	710
																				710	800
-	-	-	-	0	-56	0	-90	0	-140	0	-230	0	-360	0	-560	0	-	-	-	800	900
																				900	1 000
-	-	-	-	0	-66	0	-105	0	-165	0	-260	0	-420	0	-660	0	-	-	-	1 000	1 120
																				1 120	1 250
-	-	-	-	0	-78	0	-125	0	-195	0	-310	0	-500	0	-780	0	-	-	-	1 250	1 400
																				1 400	1 600

Unit : μm

m6		n5		n6		p5		p6		r6		r7		Basic tolerance				Diameter division mm	
High	Low	High	Low	High	Low	High	Low	High	Low	High	Low	High	Low	IT2	IT3	IT5	IT7	Over	incl.
+12	+4	+13	+8	+16	+8	+17	+12	+20	+12	+23	+15	+27	+15	1.5	2.5	5	12	3	6
+15	+6	+16	+10	+19	+10	+21	+15	+24	+15	+28	+19	+34	+19	1.5	2.5	6	15	6	10
+18	+7	+20	+12	+23	+12	+26	+18	+29	+18	+34	+23	+41	+23	2	3	8	18	10	18
+21	+8	+24	+15	+28	+15	+31	+22	+35	+22	+41	+28	+49	+28	2.5	4	9	21	18	30
+25	+9	+28	+17	+33	+17	+37	+26	+42	+26	+50	+34	+59	+34	2.5	4	11	25	30	40
																		40	50
+30	+11	+33	+20	+39	+20	+45	+32	+51	+32	+60	+41	+71	+41	3	5	13	30	50	65
																		65	80
+35	+13	+38	+23	+45	+23	+52	+37	+59	+37	+73	+51	+86	+51	4	6	15	35	80	100
																		100	120
+40	+15	+45	+27	+52	+27	+61	+43	+68	+43	+88	+63	+103	+63	5	8	18	40	120	140
																		140	160
																		160	180
+46	+17	+51	+31	+60	+31	+70	+50	+79	+50	+106	+77	+123	+77	7	10	20	46	180	200
																		200	225
																		225	250
+52	+20	+57	+34	+66	+34	+79	+56	+88	+56	+126	+94	+146	+94	8	12	23	52	250	280
																		280	315
+57	+21	+62	+37	+73	+37	+87	+62	+98	+62	+144	+108	+165	+108	9	13	25	57	315	355
																		355	400
+63	+23	+67	+40	+80	+40	+95	+68	+108	+68	+166	+126	+189	+126	10	15	27	63	400	450
																		450	500
+70	+26	-	-	+88	+44	-	-	+122	+78	+194	+150	+220	+150	-	-	-	70	500	560
																		560	630
+80	+30	-	-	+100	+50	-	-	+138	+88	+225	+175	+255	+175	-	-	-	80	630	710
																		710	800
+90	+34	-	-	+112	+56	-	-	+156	+100	+266	+210	+300	+210	-	-	-	90	800	900
																		900	1 000
+106	+40	-	-	+132	+66	-	-	+186	+120	+316	+250	+355	+250	-	-	-	105	1 000	1 120
																		1 120	1 250
+126	+48	-	-	+156	+78	-	-	+218	+140	+378	+300	+425	+300	-	-	-	125	1 250	1 400
																		1 400	1 600

Dimensional tolerance for housing bore

Diameter division mm		E7		E10		E11		E12		F6		F7		F8		G6		G7		H6	
Over	incl.	High	Low	High	Low	High	Low	High	Low	High	Low	High	Low	High	Low	High	Low	High	Low	High	Low
3	6	+32	+20	+68	+20	+95	+20	+140	+20	+18	+10	+22	+10	+28	+10	+12	+4	+16	+4	+8	0
6	10	+40	+25	+83	+25	+115	+25	+175	+25	+22	+13	+28	+13	+35	+13	+14	+5	+20	+5	+9	0
10	18	+50	+32	+102	+32	+142	+32	+212	+32	+27	+16	+34	+16	+43	+16	+17	+6	+24	+6	+11	0
18	30	+61	+40	+124	+40	+170	+40	+250	+40	+33	+20	+41	+20	+53	+20	+20	+7	+28	+7	+13	0
30	40	+75	+50	+150	+50	+210	+50	+300	+50	+41	+25	+50	+25	+64	+25	+25	+9	+34	+9	+16	0
40	50																				
50	65	+90	+60	+180	+60	+250	+60	+360	+60	+49	+30	+60	+30	+76	+30	+29	+10	+40	+10	+19	0
65	80																				
80	100	+107	+72	+212	+72	+292	+72	+422	+72	+58	+36	+71	+36	+90	+36	+34	+12	+47	+12	+22	0
100	120																				
120	140	+125	+85	+245	+85	+335	+85	+485	+85	+68	+43	+83	+43	+106	+43	+39	+14	+54	+14	+25	0
140	160																				
160	180																				
180	200																				
200	225	+146	+100	+285	+100	+390	+100	+560	+100	+79	+50	+96	+50	+122	+50	+44	+15	+61	+15	+29	0
225	250																				
250	280	+162	+110	+320	+110	+430	+110	+630	+110	+88	+56	+108	+56	+137	+56	+49	+17	+69	+17	+32	0
280	315																				
315	355	+182	+125	+355	+125	+485	+125	+695	+125	+98	+62	+119	+62	+151	+62	+54	+18	+75	+18	+36	0
355	400																				
400	450	+198	+135	+385	+135	+535	+135	+765	+135	+108	+68	+131	+68	+165	+68	+60	+20	+83	+20	+40	0
450	500																				
500	560	+215	+145	-	-	-	-	-	-	+120	+76	+146	+76	+186	+76	+66	+22	+92	+22	+44	0
560	630																				
630	710	+240	+160	-	-	-	-	-	-	+130	+80	+160	+80	+205	+80	+74	+24	+104	+24	+50	0
710	800																				
800	900	+260	+170	-	-	-	-	-	-	+142	+86	+176	+86	+226	+86	+82	+26	+116	+26	+56	0
900	1 000																				
1 000	1 120	+300	+195	-	-	-	-	-	-	+164	+98	+203	+98	+263	+98	+94	+28	+133	+28	+66	0
1 120	1 250																				
1 250	1 400	+345	+220	-	-	-	-	-	-	+188	+110	+235	+110	+305	+110	+108	+30	+155	+30	+78	0
1 400	1 600																				
1 600	1 800	+390	+240	-	-	-	-	-	-	+212	+120	+270	+120	+350	+120	+124	+32	+182	+32	+92	0
1 800	2 000																				

Unit : μm

Diameter division mm		K6		K7		M6		M7		N6		N7		P6		P7		R6		R7	
Over	incl.	High	Low	High	Low	High	Low	High	Low	High	Low	High	Low	High	Low	High	Low	High	Low	High	Low
3	6	+2	-6	+3	-9	-1	-9	0	-12	-5	-13	-4	-16	-9	-17	-8	-20	-12	-20	-11	-23
6	10	+2	-7	+5	-10	-3	-12	0	-15	-7	-16	-4	-19	-12	-21	-9	-24	-16	-25	-13	-28
10	18	+2	-9	+6	-12	-4	-15	0	-18	-9	-20	-5	-23	-15	-26	-11	-29	-20	-31	-16	-34
18	30	+2	-11	+6	-15	-4	-17	0	-21	-11	-24	-7	-28	-18	-31	-14	-35	-24	-37	-20	-41
30	40	+3	-13	+7	-18	-4	-20	0	-25	-12	-28	-8	-33	-21	-37	-17	-42	-29	-42	-25	-50
40	50																				
50	65	+4	-15	+9	-21	-5	-24	0	-30	-14	-33	-9	-39	-26	-45	-21	-51	-35	-54	-30	-60
65	80																				
80	100	+4	-18	+10	-25	-6	-28	0	-35	-16	-38	-10	-45	-30	-52	-24	-59	-44	-66	-38	-73
100	120																				
120	140	+4	-21	+12	-28	-8	-33	0	-40	-20	-45	-12	-52	-36	-61	-28	-68	-56	-81	-48	-88
140	160																				
160	180																				
180	200																				
200	225	+5	-24	+13	-33	-8	-37	0	-46	-22	-51	-14	-60	-41	-70	-33	-79	-71	-100	-63	-109
225	250																				
250	280	+5	-27	+16	-36	-9	-41	0	-52	-25	-57	-14	-66	-47	-79	-36	-88	-85	-117	-74	-126
280	315																				
315	355	+7	-29	+17	-40	-10	-46	0	-57	-26	-62	-16	-73	-51	-87	-41	-98	-97	-133	-87	-144
355	400																				
400	450	+8	-32	+18	-45	-10	-50	0	-63	-27	-67	-17	-80	-55	-95	-45	-108	-113	-153	-103	-166
450	500																				
500	560	0	-44	0	-70	-26	-70	-26	-96	-44	-88	-44	-114	-78	-122	-78	-148	-150	-194	-150	-220
560	630																				
630	710	0	-50	0	-80	-30	-80	-30	-100	-50	-100	-50	-130	-88	-138	-88	-168	-175	-225	-175	-225
710	800																				
800	900	0	-56	0	-90	-34	-90	-34	-124	-56	-112	-56	-146	-100	-156	-100	-190	-210	-266	-210	-300
900	1 000																				
1 000	1 120	0	-66	0	-105	-40	-106	-40	-145	-66	-132	-66	-171	-120	-186	-120	-225	-250	-316	-250	-355
1 120	1 250																				
1 250	1 400	0	-78	0	-125	-48	-126	-48	-173	-78	-156	-78	-203	-140	-213	-140	-265	-300	-378	-300	-425
1 400	1 600																				
1 600	1 800	0	-92	0	-150	-58	-150	-58	-208	-92	-184	-92	-242	-170	-262	-170	-320	-370	-462	-370	-520
1 800	2 000																				

Unit : μm

H7	H8	H9	H10	H11	H13	J6	Js6		J7	Js7		K5	Diameter division mm	
							High	Low		High	Low		Over	incl.
+ 12 0	+ 18 0	+ 30 0	+ 48 0	+ 75 0	+180 0	+ 5 -3	+ 4 - 4	+ 6 - 6	+ 6 - 6	+ 6 - 6	0 - 5	3	6	
+ 15 0	+ 22 0	+ 36 0	+ 58 0	+ 90 0	+220 0	+ 5 -4	+ 4.5 - 4.5	+ 8 - 7	+ 7.5 - 7.5	+ 1 - 5	+1 - 5	6	10	
+ 18 0	+ 27 0	+ 43 0	+ 70 0	+110 0	+270 0	+ 6 -5	+ 5.5 - 5.5	+10 - 8	+ 9 - 9	+2 - 6	+2 - 6	10	18	
+ 21 0	+ 33 0	+ 52 0	+ 84 0	+130 0	+330 0	+ 8 -5	+ 6.5 - 6.5	+12 - 9	+10.5 -10.5	+1 - 8	+1 - 8	18	30	
+ 25 0	+ 39 0	+ 62 0	+100 0	+160 0	+390 0	+10 -6	+ 8 - 8	+14 -11	+12.5 -12.5	+2 - 9	+2 - 9	30	40	
												40	50	
+ 30 0	+ 46 0	+ 74 0	+120 0	+190 0	+460 0	+13 -6	+ 9.5 - 9.5	+18 -12	+15 -15	+3 -10	+3 -10	50	65	
												65	80	
+ 35 0	+ 54 0	+ 87 0	+140 0	+220 0	+540 0	+16 -6	+11 -11	+22 -13	+17.5 -17.5	+2 -13	+2 -13	80	100	
												100	120	
+ 40 0	+ 63 0	+100 0	+160 0	+250 0	+630 0	+18 -7	+12.5 -12.5	+26 -14	+20 -20	+3 -15	+3 -15	120	140	
												140	160	
												160	180	
+ 46 0	+ 72 0	+115 0	+185 0	+290 0	+720 0	+22 -7	+14.5 -14.5	+30 -16	+23 -23	+2 -18	+2 -18	180	200	
												200	225	
												225	250	
+ 52 0	+ 81 0	+130 0	+210 0	+320 0	+810 0	+25 -7	+16 -16	+36 -16	+26 -26	+3 -20	+3 -20	250	280	
												280	315	
+ 57 0	+ 89 0	+140 0	+230 0	+360 0	+890 0	+29 -7	+18 -18	+39 -18	+28.5 -28.5	+3 -22	+3 -22	315	355	
												355	400	
+ 63 0	+ 97 0	+155 0	+250 0	+400 0	+970 0	+33 -7	+20 -20	+43 -20	+31.5 -31.5	+2 -25	+2 -25	400	450	
												450	500	
+ 70 0	+110 0	+175 0	+280 0	+440 0	- 0	- -	+22 -22	- -	+35 -35	- -	- -	500	560	
												560	630	
+ 80 0	+125 0	+200 0	+320 0	+500 0	- 0	- -	+25 -25	- -	+40 -40	- -	- -	630	710	
												710	800	
+ 90 0	+140 0	+230 0	+360 0	+560 0	- 0	- -	+28 -28	- -	+45 -45	- -	- -	800	900	
												900	1 000	
+105 0	+165 0	+260 0	+420 0	+660 0	- 0	- -	+33 -33	- -	+52.5 -52.5	- -	- -	1 000	1 120	
												1 120	1 250	
+125 0	+195 0	+310 0	+500 0	+780 0	- 0	- -	+39 -39	- -	+62.5 -62.5	- -	- -	1 250	1 400	
												1 400	1 600	
+150 0	+230 0	+370 0	+600 0	+920 0	- 0	- -	+46 -46	- -	+75 -75	- -	- -	1 600	1 800	
												1 800	2 000	

Inch - Millimeter conversion table

1in.=25.4mm

Inch		0"	1"	2"	3"	4"	5"	6"	7"	8"	9"
Fraction	Decimals										
1/64	0.015625	0.397	25.400	50.800	76.200	101.600	127.000	152.400	177.800	203.200	228.600
1/32	0.031250	0.794	25.797	51.197	76.597	101.997	127.397	152.797	178.197	203.597	228.997
3/64	0.046875	1.191	26.194	51.594	76.994	102.394	127.794	153.194	178.594	203.994	229.394
1/16	0.062500	1.588	26.591	51.991	77.391	102.791	128.191	153.591	178.991	204.391	229.791
5/64	0.078125	1.984	26.988	52.388	77.788	103.188	128.588	153.988	179.388	204.788	230.188
3/32	0.093750	2.381	27.384	52.784	78.184	103.584	128.984	154.384	179.784	205.184	230.584
7/64	0.109375	2.778	27.781	53.181	78.581	103.981	129.381	154.781	180.181	205.581	230.981
1/ 8	0.125000	3.175	28.178	53.578	78.978	104.378	129.778	155.178	180.578	205.978	231.378
9/64	0.140625	3.572	28.575	53.975	79.375	104.775	130.175	155.575	180.975	206.375	231.775
5/32	0.156250	3.969	28.972	54.372	79.772	105.172	130.572	155.972	181.372	206.772	232.172
11/64	0.171875	4.366	29.369	54.769	80.169	105.569	130.969	156.369	181.769	207.169	232.569
3/16	0.187500	4.762	29.766	55.166	80.566	105.966	131.366	156.766	182.166	207.566	232.966
13/64	0.203125	5.159	30.162	55.562	80.962	106.362	131.762	157.162	182.562	207.962	233.362
7/32	0.218750	5.556	30.559	55.959	81.359	106.759	132.159	157.559	182.959	208.359	233.759
15/64	0.234375	5.953	30.956	56.356	81.756	107.156	132.556	157.956	183.356	208.756	234.156
1/ 4	0.250000	6.350	31.353	56.753	82.153	107.553	132.953	158.353	183.753	209.153	234.553
17/64	0.265625	6.747	31.750	57.150	82.550	107.950	133.350	158.750	184.150	209.550	234.950
9/32	0.281250	7.144	31.547	57.547	82.947	108.347	133.747	159.147	184.547	209.947	235.347
19/64	0.296875	7.541	32.544	57.944	83.344	108.744	134.144	159.544	184.944	210.344	235.744
5/16	0.312500	7.938	32.941	58.341	83.741	109.141	134.541	159.941	185.341	210.741	236.141
21/64	0.328125	8.334	33.338	58.738	84.138	109.538	134.938	160.338	185.738	211.138	236.538
11/32	0.343750	8.731	33.734	59.134	84.534	109.934	135.334	160.734	186.134	211.534	236.934
23/64	0.359375	9.128	34.131	59.531	84.931	110.331	135.731	161.131	186.531	211.931	237.331
3/ 8	0.375000	9.525	34.528	59.928	85.328	110.728	136.128	161.528	186.928	212.328	237.728
25/64	0.390625	9.922	34.925	60.325	85.725	111.125	136.525	161.925	187.325	212.725	238.125
13/32	0.406250	10.319	35.322	60.722	86.122	111.522	136.922	162.322	187.722	213.122	238.522
27/64	0.421875	10.716	35.719	61.119	86.519	111.919	137.319	162.719	188.119	213.519	238.919
7/16	0.437500	11.112	36.116	61.516	86.916	112.316	137.716	163.116	188.516	213.916	239.316
29/64	0.453125	11.509	61.912	61.912	87.312	112.721	138.112	163.512	188.912	214.312	239.712
15/32	0.468750	11.906	62.309	62.309	87.709	113.109	138.509	163.909	189.309	214.709	240.109
31/64	0.484375	12.303	62.706	62.706	88.106	113.506	138.906	164.306	189.706	215.106	240.506
1/ 2	0.500000	12.700	63.103	63.103	88.503	113.903	139.303	164.703	190.103	215.503	240.903
33/64	0.515625	13.097	63.500	63.500	88.900	114.300	139.700	165.100	190.500	215.900	241.300
17/32	0.531250	13.494	63.897	63.897	89.297	114.697	140.097	165.497	190.897	216.297	241.697
35/64	0.546875	13.891	64.294	64.294	89.694	115.094	140.494	165.894	191.294	216.694	242.094
9/16	0.562500	14.288	64.691	64.691	90.091	115.491	140.891	166.291	191.691	217.091	242.491
37/64	0.578125	14.684	90.488	90.488	90.488	115.888	141.283	166.688	192.088	217.488	242.888
19/32	0.593750	15.081	90.884	90.884	90.884	116.284	141.684	167.084	192.484	217.884	243.284
39/64	0.609375	15.478	91.281	91.281	91.281	116.681	142.081	167.481	192.881	218.281	243.681
5/ 8	0.625000	15.875	91.678	91.678	91.678	117.078	142.478	167.878	193.278	218.678	244.078
41/64	0.640625	16.272	92.075	92.075	92.075	117.475	142.875	168.275	193.675	219.075	244.475
21/32	0.656250	16.669	92.472	92.472	92.472	117.872	143.272	168.672	194.072	219.472	244.872
43/64	0.671875	17.066	92.869	92.869	92.869	118.269	143.669	169.069	194.469	219.869	245.269
11/16	0.687500	17.462	93.266	93.266	93.266	118.666	144.066	169.466	194.866	220.266	245.666
45/64	0.703125	17.859	93.662	93.662	93.662	119.062	144.462	169.862	195.262	220.662	246.062
23/32	0.718750	18.256	94.059	94.059	94.059	119.459	144.859	170.259	195.659	221.056	246.459
47/64	0.734375	18.653	94.456	94.456	94.456	119.856	145.256	170.656	196.056	221.456	246.856
3/ 4	0.750000	19.050	94.853	94.853	94.853	120.253	145.653	171.053	196.453	221.853	247.253
49/64	0.765625	19.447	95.250	95.250	95.250	120.650	146.050	171.450	196.850	222.250	247.650
25/32	0.781250	19.844	95.647	95.647	95.647	121.047	146.447	171.847	197.247	222.647	248.047
51/64	0.796875	20.241	96.044	96.044	96.044	121.444	146.844	172.244	197.644	223.044	248.444
13/16	0.812500	20.638	96.441	96.441	96.441	121.841	147.241	172.641	198.041	223.441	248.841
53/64	0.828125	21.034	96.838	96.838	96.838	122.238	147.638	173.038	198.438	223.838	249.238
27/32	0.843750	21.431	97.234	97.234	97.234	122.634	148.034	173.434	198.834	224.234	249.634
55/64	0.859375	21.828	97.631	97.631	97.631	123.031	148.431	173.831	199.231	224.631	250.031
7/ 8	0.875000	22.225	98.028	98.028	98.028	123.428	148.828	174.228	199.628	225.028	250.428
57/64	0.890625	22.622	98.425	98.425	98.425	123.825	149.225	174.625	200.025	225.425	250.825
39/32	0.906250	23.019	98.822	98.822	98.822	124.222	149.622	175.022	200.422	225.822	251.222
59/64	0.921875	23.416	99.219	99.219	99.219	124.619	150.019	175.419	200.819	226.219	251.619
15/16	0.937500	23.812	99.616	99.616	99.616	125.016	150.416	175.816	201.216	226.616	252.016
61/64	0.953125	24.209	100.012	100.012	100.012	125.412	150.812	176.212	201.612	227.012	252.412
31/32	0.968750	24.606	100.409	100.409	100.409	125.809	151.209	176.609	202.009	227.409	252.809
63/64	0.984375	25.003	100.806	100.806	100.806	126.206	151.606	177.006	202.406	227.806	253.206
		25.400	101.203	101.203	101.203	126.603	152.003	177.403	202.803	228.203	253.603