



Spherical roller bearings



9 Spherical roller bearings

Designs and variants	775	
CC, CA and E design bearings	775	
Sealed bearings	776	
Bearings for vibratory applications	778	
Bearings for wind energy applications	780	
Customized bearings	780	
Bearings for high-speed applications	780	
Bearing data	781	
(Dimension standards, tolerances, internal clearance, permissible misalignment)		
Loads	784	
(Minimum load, axial load carrying capacity, equivalent dynamic bearing load, equivalent static bearing load)		
Temperature limits	785	
Permissible speed	785	
Design considerations	786	
Free space on both sides of the bearing	786	
Abutments for sealed bearings	786	
Bearings on sleeves	787	
Appropriate bearing housings	788	
Mounting	788	
Designation system	790	
Product tables		
9.1 Spherical roller bearings	792	
9.2 Spherical roller bearings on an adapter sleeve	824	Other spherical roller bearings
9.3 Spherical roller bearings on a withdrawal sleeve ..	832	NoWear coated bearings
		1059



9 Spherical roller bearings

More information

General bearing knowledge	17
Bearing selection process	59
Lubrication	109
Bearing interfaces	139
Seat tolerances for standard conditions	148
Selecting internal clearance	182
Sealing, mounting and dismounting	193

Mounting instructions for individual bearings → skf.com/mount

SKF Drive-up Method → skf.com/drive-up

SKF bearing maintenance handbook ISBN 978-91-978966-4-1

Spherical roller bearings have two rows of symmetrical rollers, a common sphered outer ring raceway and two inner ring raceways inclined at an angle to the bearing axis (fig. 1). The centre point of the sphere in the outer ring raceway is at the bearing axis.

Bearing features

- **Accommodate misalignment**
Spherical roller bearings are self-aligning like self-aligning ball bearings or CARB bearings (fig. 2).
- **High load carrying capacity**
Spherical roller bearings are designed to accommodate both heavy radial loads and axial loads in both directions.

- **Long service life**
The rollers are manufactured to such tight dimensional and geometrical tolerances that they are practically identical in a roller set. The symmetrical rollers self-adjust (fig. 3), providing optimal load distribution along the roller length and together with the special profile prevent stress peaks at the roller ends (fig. 4).
- **Low friction**
Self-guiding rollers keep friction and frictional heat at low levels (fig. 5). A floating guide ring guides unloaded rollers so that they enter the load zone in the optimal position.
- **Robust**
All SKF spherical roller bearings contain strong window- or prong-type cages.

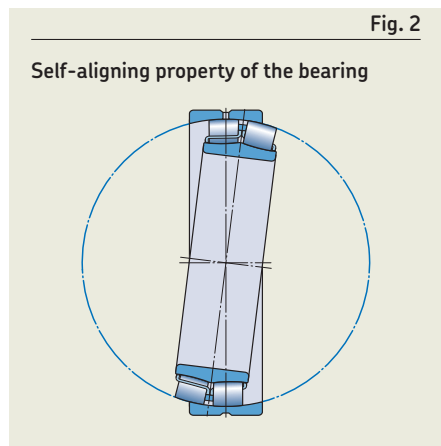
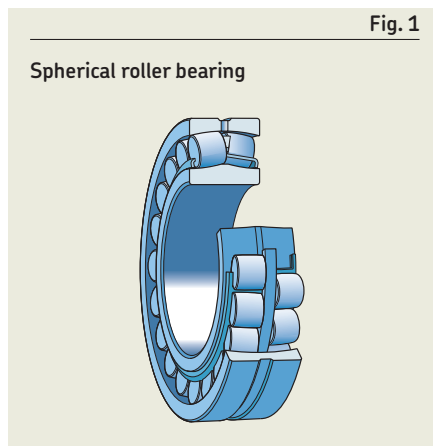

Designs and variants

SKF standard assortment

The assortment of SKF spherical roller bearings is the widest available on the market. The standard assortment includes:

- CC, CA and E design bearings
- sealed bearings
- bearings for vibratory applications
- bearings for wind energy applications

All SKF spherical roller bearings are SKF Explorer bearings (page 7) and almost all bearings are available with the option of a tapered bore. Depending on the bearing series, the tapered bore has:

- a taper 1:12 (designation suffix K)
- a taper 1:30 (designation suffix K30)

For sizes and variants not listed in the product tables, contact SKF.

CC, CA and E design bearings

CC design bearings

- have two stamped window-type steel cages, an inner ring without flanges and a floating guide ring centred on the inner ring (fig. 6)
- are indicated in the product table by the designation suffix C or CC
- are indicated in the product table by the designation suffix EC or ECC for larger bearings and have an optimized internal design for increased load carrying capacity

CA design bearings

- have a machined double prong-type brass cage, an inner ring with a retaining flange on both sides and a floating guide ring centred on the inner ring (fig. 6)
- The flanges on the inner ring are designed to keep the rollers in place when swivelling the bearing during mounting or maintenance and are not designed to guide the rollers or accommodate any axial load.

- are indicated in the product table by the designation suffix CA
- are indicated in the product table by the designation suffix ECA for larger bearings and have an optimized internal design for increased load carrying capacity

E design bearings

- have two stamped window-type steel cages, an inner ring without flanges and a floating guide ring centred on the inner ring ($d \leq 65$ mm) or on the cages ($d > 65$ mm) (fig. 6)
- are indicated in the product table by the designation suffix E
- have an optimized internal design for increased load carrying capacity

Cages

For information about the suitability of cages, refer to *Cages*, page 187.

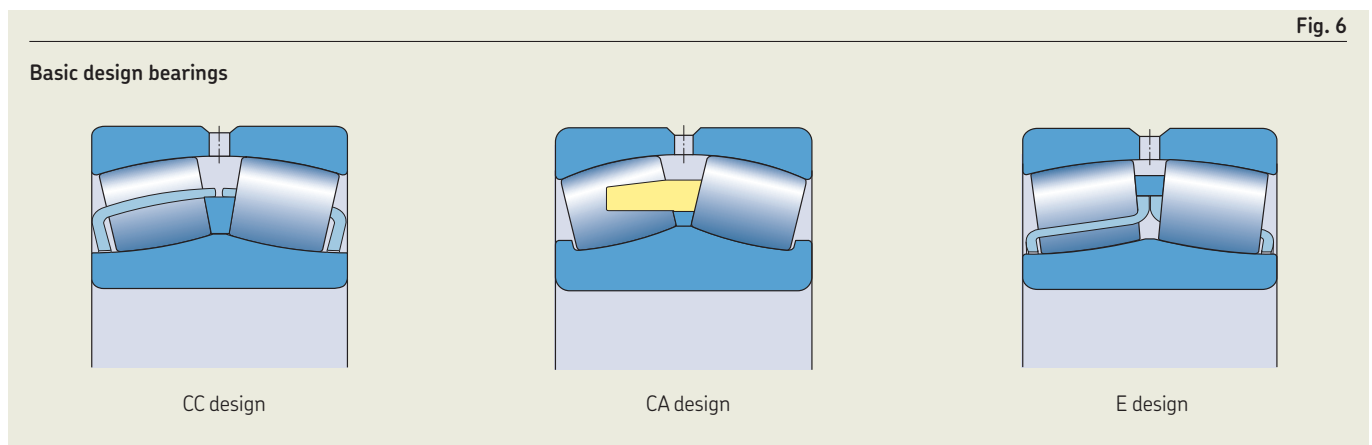
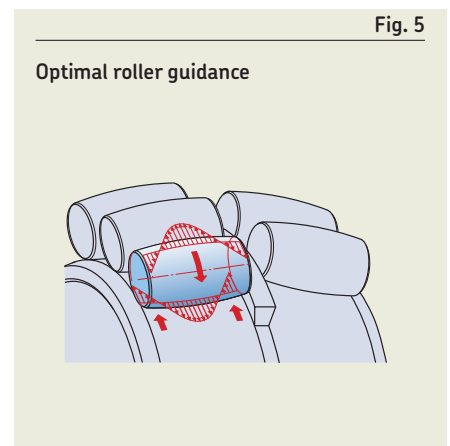
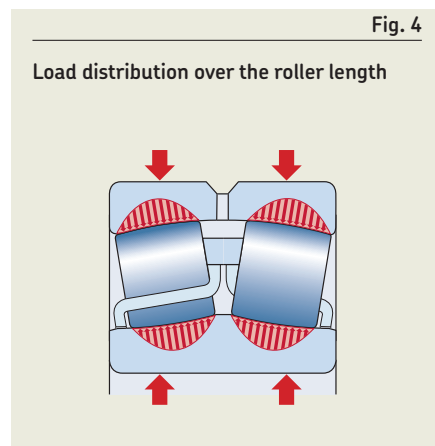
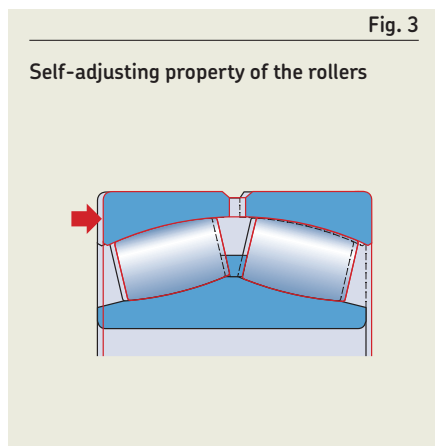

9 Spherical roller bearings

Annular groove and lubrication holes

- CC and CA design bearings are available with an annular groove and three lubrication holes in the outer ring (designation suffix W33) or three lubrication holes in the outer ring (designation suffix W20) (fig. 7).
- E design bearings have an annular groove and three lubrication holes as standard (fig. 6, page 775). This feature is not identified in the bearing designation (no designation suffix).

Sealed bearings

- have the same features and internal design as open spherical roller bearings
- are available with a cylindrical bore as standard
- are supplied grease lubricated and should not be washed
- are equipped with an annular groove and three lubrication holes in the outer ring, except for those with the designation suffix W
- are fitted with a contact seal, on one or both sides, made of one of the following materials:
 - sheet steel reinforced NBR (designation suffix CS or RS)
 - sheet steel reinforced HNBR (designation suffix CS5 or RS5)
 - sheet steel reinforced FKM (designation suffix CS2)

The seals are fitted in a recess on the outer ring and seal against the inner ring (fig. 8). On larger bearings, the seals are fixed by a retaining ring (fig. 9).

Bearings sealed on both sides are lubricated for the life of the bearing and are virtually maintenance-free (*Grease life for sealed bearings*). They are filled with one of the following greases (table 1):

- SKF LGEP 2 grease (designation suffix VT143) as standard
- SKF LGHB 2 grease (designation suffix GEM9) or LGWM 2 grease (designation suffix GLE) on request

For additional information about greases, refer to *Selecting a suitable SKF grease*, page 116.

Grease life for sealed bearings

The grease life for sealed bearings is presented as L_{10} , i.e. the time period at the end of which 90% of the bearings are still reliably lubricated, and depends on the load, operating temperature and speed value. It can be obtained for bearings with standard SKF LGEP 2 grease (designation suffix VT143) from:

- diagram 1, for light load ($P \leq 0,067 C$)
- diagram 2, page 778, for normal load ($P \leq 0,125 C$)

The grease life is valid under the following operating conditions:

- horizontal shaft
- inner ring rotation
- operating temperature within the green temperature zone of the grease (table 1)
- stationary machine
- low vibration levels
- load ratio $F_a/F_r \leq e$ (product table, page 792)
- rotational speed below the limiting speed (product table) and below the limits listed in table 2, page 778

For other operating conditions, the grease life can be estimated by multiplying the relubrication interval for open bearings (*Estimating the relubrication interval for grease*, page 111) by a factor of 2,7.

Fig. 7

Annular groove and lubrication holes

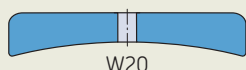
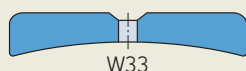

Fig. 8

Seals fitted in outer ring recess

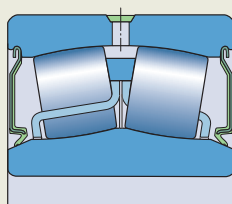
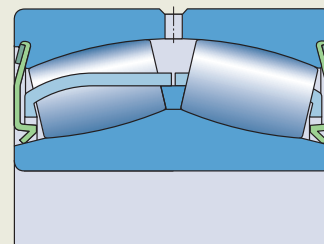

Fig. 9

Seals fixed by a retaining ring



Relubrication of sealed bearings

When the required service life is longer than the grease life, the bearings may require relubrication. A suitable grease quantity to relubricate sealed bearings can be obtained using

$$G_p = 0,0015 D B$$

where

- G_p = grease quantity [g]
- D = bearing outside diameter [mm]
- B = bearing width [mm]

The grease should be applied slowly through the lubrication holes in the outer ring, preferably while the bearing is rotating to avoid damaging the seals. SKF recommends relubricating with the same grease as the initial fill.

⚠ WARNING

Seals made of FKM (fluoro rubber) exposed to an open flame or temperatures above 300 °C (570 °F) are a health and environmental hazard! They remain dangerous even after they have cooled.

Read and follow the safety precautions on [page 197](#).

Diagram 1

Grease life for sealed spherical roller bearings with designation suffix VT143 where $P \leq 0,067 C$

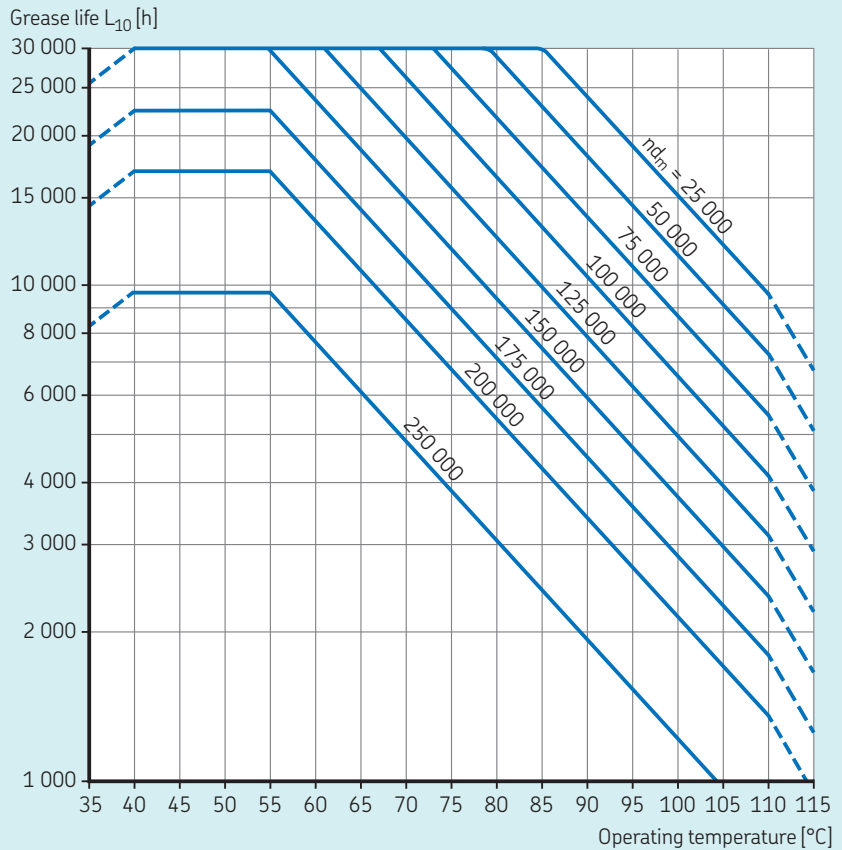

n = rotational speed [r/min]
 d_m = bearing mean diameter [mm]
 $= 0,5 (d + D)$

Table 1

Technical specifications of SKF greases for sealed spherical roller bearings

Designation suffix	Grease	Temperature range ¹⁾							Thickener	Base oil type	NLGI grade	Base oil viscosity [mm ² /s]	
		-50	0	50	100	150	200	250				at 40 °C (105 °F)	at 100 °C (210 °F)
VT143	LGEP 2	[Color scale: -50 to 250 °C]							Lithium soap	Mineral	2	200	16
GEM9	LGHB 2	[Color scale: -50 to 250 °C]							Calcium complex sulphonate	Mineral	2	400	26,5
GLE	LGWM 2	[Color scale: -50 to 250 °C]							Calcium complex sulphonate	Mineral/Synthetic	2	80	8,6

¹⁾ Refer to the SKF traffic light concept ([page 117](#)).

Bearings for vibratory applications

- are available in the 223 series
- are available with a cylindrical or tapered bore
- have C4 radial internal clearance as standard
- are equipped with an annular groove and three lubrication holes in the outer ring
- are available with a PTFE coated cylindrical bore (designation suffix VA406), which prevents fretting corrosion between the shaft and the bearing bore, for shaft thermal elongation in non-locating bearing positions that have a rotating outer ring load

Therefore, shafts do not require special heat treatments or coatings.

- are manufactured to one of the following designs (fig. 10):
 - E/VA405 bearings have two surface-hardened stamped window-type steel cages, an inner ring without flanges and a guide ring centred on the inner ring or on the cages.
 - EJA/VA405 and CCJA/W33VA405 bearings have two surface-hardened stamped window-type steel cages, an inner ring without flanges and a guide ring centred on the outer ring raceway.

Diagram 2

Grease life for sealed spherical roller bearings with designation suffix VT143 where $P \leq 0,125 C$

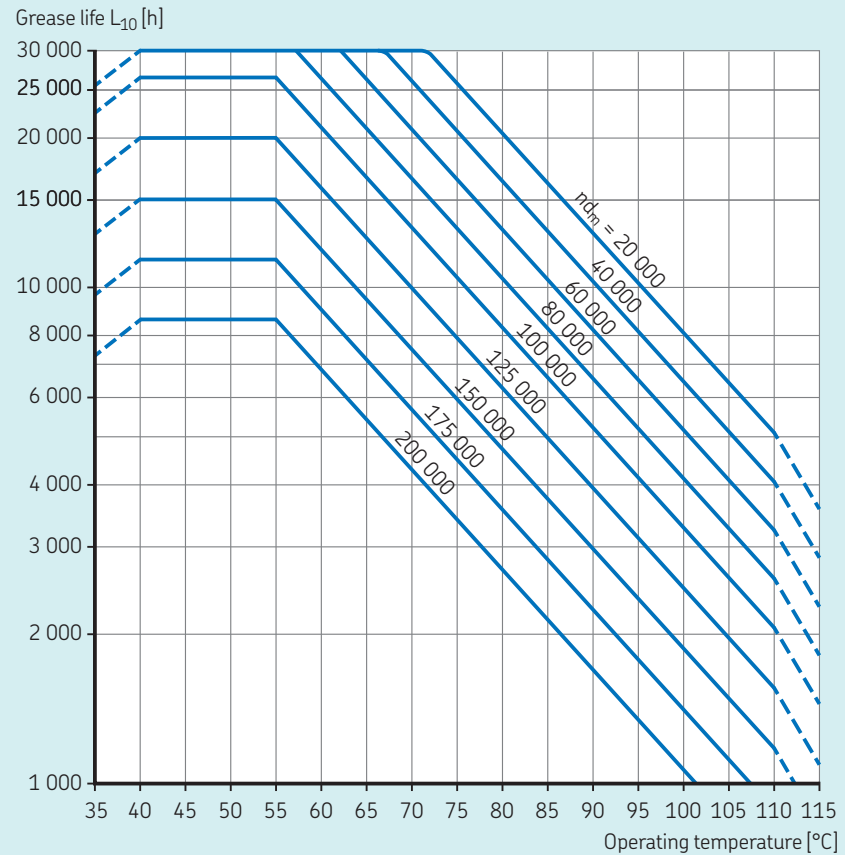

n = rotational speed [r/min]
 d_m = bearing mean diameter [mm]
 $= 0,5 (d + D)$

Table 2

Speed limits for grease life calculation for sealed spherical roller bearings

Bearing series	Maximum nd_m value	
	Light load ($P \leq 0,067 C$)	Normal load ($P \leq 0,125 C$)
–	mm/min	
222, 239	250 000	200 000
223, 230, 231, 232, 240	250 000	150 000
241	150 000	80 000

Acceleration

Vibratory applications induce accelerations of the rollers and cages in the bearings. This puts extra demands on the bearing design. SKF spherical roller bearings for vibratory applications can withstand considerably higher accelerations than corresponding standard bearings. The permissible acceleration depends on the lubricant and the mode of acceleration.

- **Mode 1**

The bearing is subjected to a rotating outer ring load in combination with a rotating acceleration field, or an internally induced angular acceleration field caused by rapid speed variations. These accelerations cause the unloaded rollers to generate cyclic loads on the cages. Examples: vibrating screens (fig. 11), exciters, planetary gears and general arrangements subjected to rapid starts or rapid speed variations.

- **Mode 2**

The bearing is subjected to impact loads, which generate a linear acceleration in a constant radial direction, causing the unloaded rollers to “hammer” the cage pockets. Example: acceleration generated when rail wheels roll over rail joints (fig. 12).

Road rollers, where the roller is vibrating against a relatively hard surface, are subjected to a combination of mode 1 and 2 acceleration. Values for the permissible acceleration are listed in the [product table, page 792](#), and are valid for oil lubricated bearings. The values are expressed in multiples of g, where g is the acceleration of gravity ($g = 9,81 \text{ m/s}^2$).

System solutions for vibrating screens

In addition to single bearings for vibrating screens, SKF has developed fault detection and bearing arrangements that can improve performance, reduce maintenance and monitor machine condition in vibratory equipment.

Fig. 10

Bearings for vibratory applications

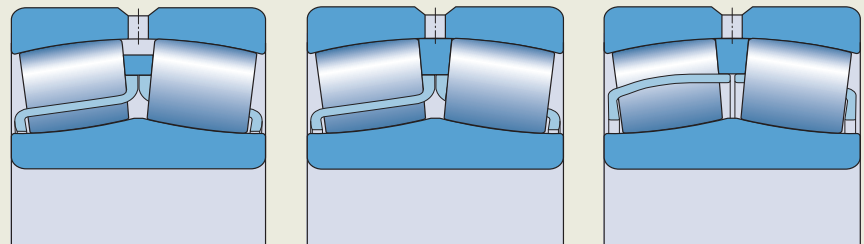

E/VA405 design

EJA/VA405 design

CCJA/W33VA405 design

⚠ WARNING

PTFE coatings exposed to an open flame or temperatures above 300 °C (570 °F) are a health and environmental hazard! They remain dangerous even after they have cooled.

Read and follow the safety precautions on [page 197](#).

Fig. 11

Vibrating screen

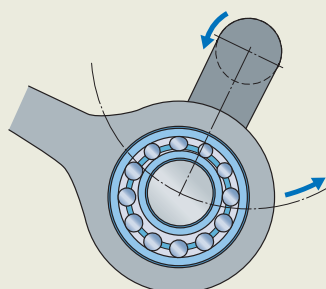
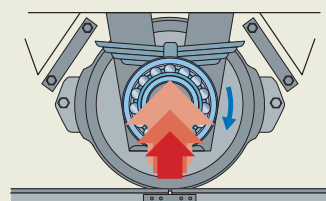

Fig. 12

Rail wheel rolls over rail joints



Bearings for wind energy applications

- are available in the 240 series, from $d \geq 530$ mm
- are designed explicitly for wind turbine main shafts
- have an optimized internal geometry with large diameter rollers and increased contact angle for increased axial load carrying capacity (fig. 13)
- have a roller-guided cast iron cage for increased robustness
- have no guide ring
- have a wide outer ring lubrication groove and six lubrication holes
- are indicated in the [product table](#), [page 792](#), by the designation suffix BC

Customized bearings

SKF can customize bearings to meet the needs of applications where the bearings are subjected to unique operating conditions. For example, bearings for:

- printing presses, paper mills or high-precision coating systems
- very arduous operating conditions, e.g. continuous casters
- bearings for high-speed applications
- mounting with loose fit on roll necks
- railway vehicles

Bearings for high-speed applications

- have 50% higher limiting speeds than standard bearings
- are available in the 223, 232, 240 and 241 series in a special execution
- are identified by the designation suffix VA991
- address a market need in multi-megawatt industrial gearboxes

For additional information about application-specific spherical roller bearings, contact SKF.

Fig. 13

Bearing for wind turbine main shaft

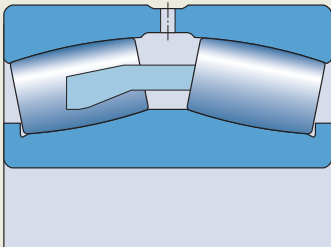

Fig. 14

Rotating shaft deflection

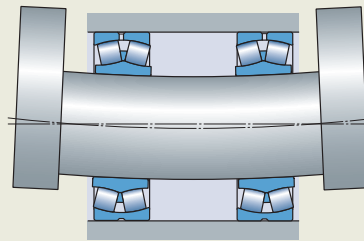

Table 3

Width tolerances for SKF Explorer spherical roller bearings

Bore diameter		Width tolerances	
d		$t_{\Delta Bs}$	L
>	≤	U	
mm		μm	
18	80	0	-60
80	250	0	-80
250	300	0	-100

Table 6

Permissible angular misalignment

Bearing series	Permissible angular misalignment
Sizes	

–	°
Series 213	2
Series 222 Sizes < 52 Sizes ≥ 52	2 1,5
Series 223	3
Series 230 Sizes < 56 Sizes ≥ 56	2 2,5
Series 231 Sizes < 60 Sizes ≥ 60	2 3
Series 232 Sizes < 52 Sizes ≥ 52	2,5 3,5
Series 238	1,5
Series 239	1,5
Series 240	2
Series 241 Sizes < 64 Sizes ≥ 64	2,5 3,5
Series 248	1,5
Series 249	2,5

Bearing data

Dimension standards	Boundary dimensions: ISO 15, except for the width of sealed bearings with a BS2- designation prefix
Tolerances For additional information → page 35	Normal P5 geometrical tolerance on request (designation suffix C08) Except for: <ul style="list-style-type: none"> • Bearings with $d \leq 300$ mm: <ul style="list-style-type: none"> – width tolerance at least 50% tighter than ISO standard (table 3) – P5 geometrical tolerance • Bearings for vibratory applications: <ul style="list-style-type: none"> – P5 bore diameter – P6 outside diameter Values: ISO 492, (table 2, page 38 , to table 4, page 40)
Internal clearance For additional information → page 182	Normal, C3 Check availability of C2, C4 or C5 clearance classes Bearings for vibratory applications: C4 Values: <ul style="list-style-type: none"> • cylindrical bore (table 4, page 782) • tapered bore (table 5, page 783) Values are in accordance with ISO 5753-1 (as far as standardized) and are valid for unmounted bearings under zero measuring load.
Permissible misalignment	<ul style="list-style-type: none"> • Guideline values for light to normal loads ($P \leq 0,1 C$) and constant position of misalignment relative to the outer ring: table 6 Whether these values can be fully exploited depends on the design of the bearing arrangement, the bearing abutments in the housing, etc. • When the position of the misalignment is not constant relative to the outer ring, additional sliding may occur in the bearing, limiting misalignment to a few tenths of a degree. Examples are: <ul style="list-style-type: none"> – vibrating screens with rotating imbalance and therefore rotating deflection of the shaft (fig. 14) – deflection-compensating rolls of paper machines where the stationary shaft is not straight • To avoid detrimental effects on sealing performance, misalignment for sealed bearings should not exceed $0,5^\circ$.



Radial internal clearance of spherical roller bearings with a cylindrical bore

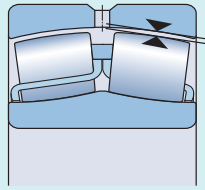

Bore diameter		Radial internal clearance									
d		C2		Normal		C3		C4		C5	
>	≤	min.	max.	min.	max.	min.	max.	min.	max.	min.	max.
mm		μm									
18	24	10	20	20	35	35	45	45	60	60	75
24	30	15	25	25	40	40	55	55	75	75	95
30	40	15	30	30	45	45	60	60	80	80	100
40	50	20	35	35	55	55	75	75	100	100	125
50	65	20	40	40	65	65	90	90	120	120	150
65	80	30	50	50	80	80	110	110	145	145	185
80	100	35	60	60	100	100	135	135	180	180	225
100	100	40	75	75	120	120	160	160	210	210	260
120	140	50	95	95	145	145	190	190	240	240	300
140	160	60	110	110	170	170	220	220	280	280	350
160	180	65	120	120	180	180	240	240	310	310	390
180	200	70	130	130	200	200	260	260	340	340	430
200	225	80	140	140	220	220	290	290	380	380	470
225	250	90	150	150	240	240	320	320	420	420	520
250	280	100	170	170	260	260	350	350	460	460	570
280	315	110	190	190	280	280	370	370	500	500	630
315	355	120	200	200	310	310	410	410	550	550	690
355	400	130	220	220	340	340	450	450	600	600	750
400	450	140	240	240	370	370	500	500	660	660	820
450	500	140	260	260	410	410	550	550	720	720	900
500	560	150	280	280	440	440	600	600	780	780	1 000
560	630	170	310	310	480	480	650	650	850	850	1 100
630	710	190	350	350	530	530	700	700	920	920	1 190
710	800	210	390	390	580	580	770	770	1 010	1 010	1 300
800	900	230	430	430	650	650	860	860	1 120	1 120	1 440
900	1 000	260	480	480	710	710	930	930	1 220	1 220	1 570
1 000	1 120	290	530	530	780	780	1 020	1 020	1 330	1 330	1 720
1 120	1 250	320	580	580	860	860	1 120	1 120	1 460	1 460	1 870
1 250	1 400	350	640	640	950	950	1 240	1 240	1 620	1 620	2 060
1 400	1 600	400	720	720	1 060	1 060	1 380	1 380	1 800	1 800	2 300
1 600	1 800	450	810	810	1 180	1 180	1 550	1 550	2 000	2 000	2 550

Table 5

Radial internal clearance of spherical roller bearings with a tapered bore

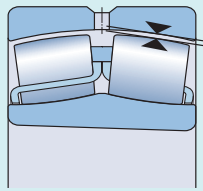

Bore diameter		Radial internal clearance										
d	>	≤	C2 min.	max.	Normal min.	max.	C3 min.	max.	C4 min.	max.	C5 min.	max.
mm			µm									
24	30		20	30	30	40	40	55	55	75	–	–
30	40		25	35	35	50	50	65	65	85	85	105
40	50		30	45	45	60	60	80	80	100	100	130
50	65		40	55	55	75	75	95	95	120	120	160
65	80		50	70	70	95	95	120	120	150	150	200
80	100		55	80	80	110	110	140	140	180	180	230
100	120		65	100	100	135	135	170	170	220	220	280
120	140		80	120	120	160	160	200	200	260	260	330
140	160		90	130	130	180	180	230	230	300	300	380
160	180		100	140	140	200	200	260	260	340	340	430
180	200		110	160	160	220	220	290	290	370	370	470
200	225		120	180	180	250	250	320	320	410	410	520
225	250		140	200	200	270	270	350	350	450	450	570
250	280		150	220	220	300	300	390	390	490	490	620
280	315		170	240	240	330	330	430	430	540	540	680
315	355		190	270	270	360	360	470	470	590	590	740
355	400		210	300	300	400	400	520	520	650	650	820
400	450		230	330	330	440	440	570	570	720	720	910
450	500		260	370	370	490	490	630	630	790	790	1 000
500	560		290	410	410	540	540	680	680	870	870	1 100
560	630		320	460	460	600	600	760	760	980	980	1 230
630	710		350	510	510	670	670	850	850	1 090	1 090	1 360
710	800		390	570	570	750	750	960	960	1 220	1 220	1 500
800	900		440	640	640	840	840	1 070	1 070	1 370	1 370	1 690
900	1 000		490	710	710	930	930	1 190	1 190	1 520	1 520	1 860
1 000	1 120		530	770	770	1 030	1 030	1 300	1 300	1 670	1 670	2 050
1 120	1 250		570	830	830	1 120	1 120	1 420	1 420	1 830	1 830	2 250
1 250	1 400		620	910	910	1 230	1 230	1 560	1 560	2 000	2 000	2 450
1 400	1 600		680	1 000	1 000	1 350	1 350	1 720	1 720	2 200	2 200	2 700
1 600	1 800		750	1 110	1 110	1 500	1 500	1 920	1 920	2 400	2 400	2 950



Loads

Minimum load For additional information → page 106	$P_m = 0,01 C_0$ Oil lubricated bearings: $n/n_r \leq 0,3 \rightarrow P_m = 0,003 C_0$ $0,3 < n/n_r \leq 2 \rightarrow P_m = 0,003 C_0 \left(1 + 2 \sqrt{\frac{n}{n_r} - 0,3}\right)$
Axial load carrying capacity	SKF spherical roller bearings are able to accommodate axial loads and even accommodate purely axial loads. Bearings correctly mounted on an adapter sleeve on plain shafts without fixed abutment: $F_{ap} = 0,003 B d$
Equivalent dynamic bearing load For additional information → page 91	$F_a/F_r \leq e \rightarrow P = F_r + Y_1 F_a$ $F_a/F_r > e \rightarrow P = 0,67 F_r + Y_2 F_a$
Equivalent static bearing load For additional information → page 105	$P_0 = F_r + Y_0 F_a$
	Symbols B bearing width [mm] C_0 basic static load rating [kN] (product table, page 792) d bearing bore diameter [mm] e calculation factor (product table) F_a axial load [kN] F_{ap} maximum permissible axial load [kN] F_r radial load [kN] P equivalent dynamic bearing load [kN] P_0 equivalent static bearing load [kN] P_m equivalent minimum load [kN] n rotational speed [r/min] n_r reference speed [r/min] (product table) Y_0, Y_1, Y_2 calculation factors (product table)



Temperature limits

The permissible operating temperature for spherical roller bearings can be limited by:

- the dimensional stability of the bearing rings
- the seals
- the lubricant

Where temperatures outside the permissible range are expected, contact SKF.

Bearing rings

SKF spherical roller bearings undergo a special heat treatment. The bearings are heat stabilized up to at least 200 °C (390 °F).

Seals

The permissible operating temperature for seals depends on the seal material:

- NBR: -40 to +90 °C (-40 to +195 °F)
Temperatures up to 120 °C (250 °F) can be tolerated for brief periods.
- HNBR: -40 to +150 °C (-40 to +300 °F)
- FKM: -30 to +200 °C (-20 to +390 °F)

Typically, temperature peaks are at the seal lip.

Lubricants

Temperature limits for the greases used in sealed SKF spherical roller bearings are provided in [table 1, page 777](#). For temperature limits of other SKF greases, refer to *Selecting a suitable SKF grease*, [page 116](#).

When using lubricants not supplied by SKF, temperature limits should be evaluated according to the SKF traffic light concept ([page 117](#)).

Permissible speed

The speed ratings in the [product table](#) indicate:

- the **reference speed**, which enables a quick assessment of the speed capabilities from a thermal frame of reference
- the **limiting speed**, which is a mechanical limit that should not be exceeded unless the bearing design and the application are adapted for higher speeds

For additional information, refer to *Operating temperature and speed*, [page 130](#).



Design considerations

Free space on both sides of the bearing

To prevent interference between rotating bearing parts and stationary machine parts, free space (C_a) should be provided as indicated in **fig. 15**. The requisite width of the free space depends on:

- the actual misalignment
- lubricant space requirements

The requisite free space should be at least 20 times the minimum value of the radial internal clearance in the unmounted bearing:

- with a cylindrical bore (**table 4, page 782**)
- with a tapered bore (**table 5, page 783**)

Abutments for sealed bearings

The diameter of the shaft abutment should not exceed $d_{a\max}$ (**product table, page 792**), certainly for the 1 to 2 mm closest to the bearing, to prevent interference with the seal (**fig. 16**). If the bearings are to be located axially on the shaft by a lock nut, SKF recommends using a KMFE lock nut (**fig. 17**) or fitting a spacer ring (**fig. 18**) between the bearing and the lock washer to prevent interference with the seal.

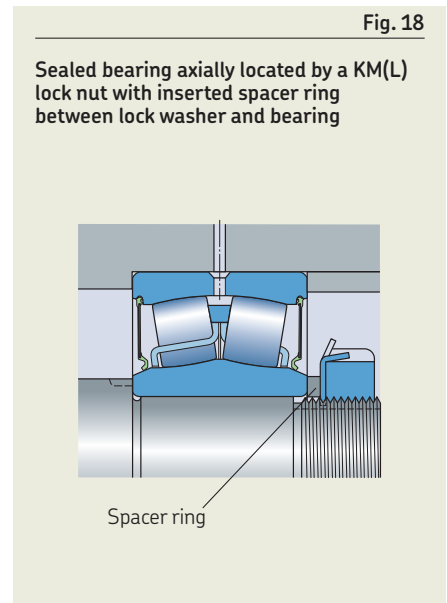
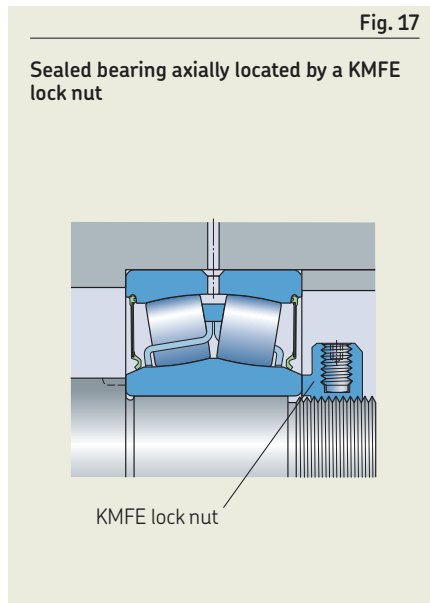
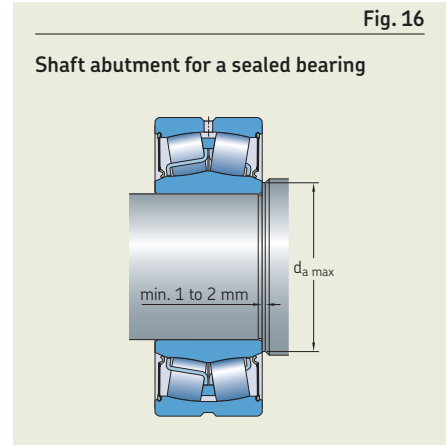
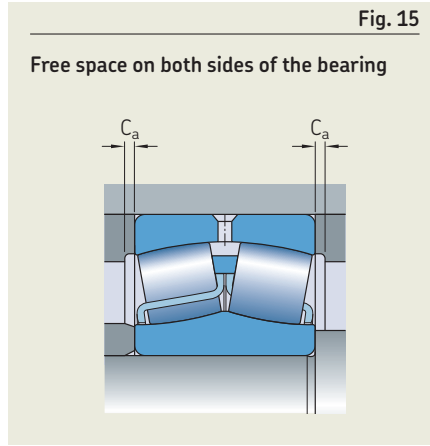

Bearings on sleeves

Spherical roller bearings with a tapered bore can be mounted with:

- an adapter sleeve on plain or stepped shafts (fig. 19):
 - SKF adapter sleeves are supplied complete with a locking device.
 - Use appropriate SKF adapter sleeve assemblies for sealed bearings (fig. 20) to prevent the locking device interfering with the seal (product table, page 824). Alternatively, a spacer ring can be inserted between the bearing and the lock washer.
- a withdrawal sleeve on stepped shafts (fig. 21)

For additional information about sleeves, refer to *Adapter sleeves*, page 1065, and *Withdrawal sleeves*, page 1087.

Fig. 19

Bearing with a tapered bore mounted with an adapter sleeve

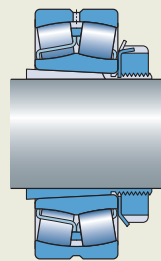

On a plain shaft

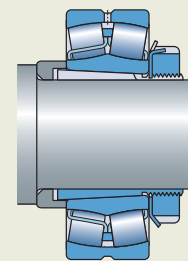

On a stepped shaft

Fig. 20

SKF adapter sleeve assembly for sealed bearings

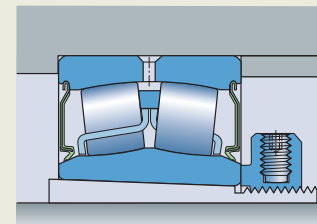
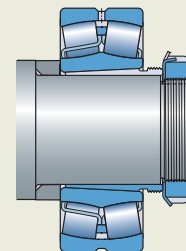

Fig. 21

Bearing with a tapered bore mounted on a stepped shaft with a withdrawal sleeve



Appropriate bearing housings

The combination of a spherical roller bearing, appropriate sleeve (where needed), and an appropriate SKF bearing housing provides a cost-effective, interchangeable and reliable solution that fulfils the demand for easy maintenance.

The comprehensive assortment of SKF bearing housings is provided online at skf.com/housings.

Mounting

During handling, the rings and roller complement of spherical roller bearings may be axially displaced from their normal position. This is especially likely where the bearings are mounted with the shaft or housing in the vertical position:

- The roller complement, together with the inner or outer ring, will move downward and result in no more clearance.
- When the bearing rings expand or contract as a result of an interference fit, preload is likely to result.

Therefore, wherever possible:

- Mount spherical roller bearings with the shaft or housing in the horizontal position.
- Rotate the inner or outer ring to align the rollers during mounting.

Where this is not feasible, use a bearing handling tool or other device to keep the bearing components arranged centrally.

Mounting sealed bearings

SKF does not recommend heating sealed spherical roller bearings above 80 °C (175 °F) during the mounting process. However, if higher temperatures are necessary, make sure that the temperature does not exceed the permissible temperature of either the seal or grease, whichever is the lowest.

Mounting bearings with a tapered bore

Bearings with a tapered bore are mounted with an interference fit. To obtain the proper degree of interference, one of the following methods can be used:

1 Measuring the clearance reduction (table 7)

2 Measuring the lock nut tightening angle (table 7)

3 Measuring the axial drive-up (table 7)

4 Applying the SKF Drive-up Method

For bearings with $d > 100$ mm, SKF recommends using the SKF Drive-up Method. This is a fast, reliable and safe method to achieve the appropriate interference fit. Additional information is available online at skf.com/drive-up.

5 Measuring the inner ring expansion

Additional information is available online at skf.com/sensormount.

For additional information about these mounting methods, refer to *Mounting bearings with a tapered bore*, page 203, or the *SKF bearing maintenance handbook*.



Table 7

Drive-up data for spherical roller bearings with a tapered bore

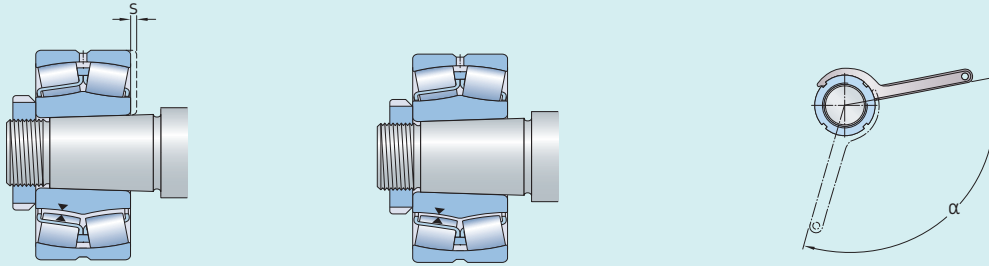

Bore diameter		Reduction of radial internal clearance		Axial drive-up ^{1) 2)}				Lock nut tightening angle ²⁾
d				s				α
>	≤	min.	max.	Taper 1:12 min.	Taper 1:12 max.	Taper 1:30 min.	Taper 1:30 max.	Taper 1:12
mm		mm		mm				°
24	30	0,01	0,015	0,25	0,29	–	–	100
30	40	0,015	0,02	0,3	0,35	–	–	115
40	50	0,02	0,025	0,37	0,44	–	–	130
50	65	0,025	0,035	0,45	0,54	1,15	1,35	115
65	80	0,035	0,04	0,55	0,65	1,4	1,65	130
80	100	0,04	0,05	0,66	0,79	1,65	2	150
100	120	0,05	0,06	0,79	0,95	2	2,35	
120	140	0,06	0,075	0,93	1,1	2,3	2,8	
140	160	0,07	0,085	1,05	1,3	2,65	3,2	
160	180	0,08	0,095	1,2	1,45	3	3,6	
180	200	0,09	0,105	1,3	1,6	3,3	4	
200	225	0,1	0,12	1,45	1,8	3,7	4,45	
225	250	0,11	0,13	1,6	1,95	4	4,85	
250	280	0,12	0,15	1,8	2,15	4,5	5,4	
280	315	0,135	0,165	2	2,4	4,95	6	
315	355	0,15	0,18	2,15	2,65	5,4	6,6	
355	400	0,17	0,21	2,5	3	6,2	7,6	
400	450	0,195	0,235	2,8	3,4	7	8,5	
450	500	0,215	0,265	3,1	3,8	7,8	9,5	
500	560	0,245	0,3	3,4	4,1	8,4	10,3	
560	630	0,275	0,34	3,80	4,65	9,50	11,60	
630	710	0,31	0,38	4,25	5,2	10,6	13	
710	800	0,35	0,425	4,75	5,8	11,9	14,5	
800	900	0,395	0,48	5,4	6,6	13,5	16,4	
900	1 000	0,44	0,535	6	7,3	15	18,3	
1 000	1 120	0,49	0,6	6,4	7,8	16	19,5	
1 120	1 250	0,55	0,67	7,1	8,7	17,8	21,7	
1 250	1 400	0,61	0,75	8	9,7	19,9	24,3	
1 400	1 600	0,7	0,85	9,1	11,1	22,7	27,7	
1 600	1 800	0,79	0,96	10,2	12,5	25,6	31,2	

Applying the recommended values prevents the inner ring from creeping, but does not ensure correct radial internal clearance in operation. Additional influences from the bearing housing fit and temperature differences between the inner and outer rings must be considered carefully when selecting the bearing radial internal clearance class (Selecting initial internal clearance, [page 183](#)).

¹⁾ Not valid for the SKF Drive-up Method.

²⁾ The listed values are valid only for solid steel shafts and general applications. They are to be used as guideline values only, as it is difficult to establish an exact starting position. Also, the axial drive-up, s, differs slightly between the different bearings series.

Designation system



Prefixes

- BS2-.. Bearing, designated by a drawing number
- ZE Bearing with SensorMount feature

Basic designation

Listed in [table 4, page 30](#)
 Figure with four digits: drawing number identification

Suffixes

Group 1: Internal design

- BC Bearing for wind turbine main shafts with roller-guided cast iron cage
- CA, CAC Retaining flanges on the inner ring, guide ring centred on the inner ring, machined brass cage
- CC(J), CJ Flangeless inner ring, guide ring centred on the inner ring, two stamped steel cages
- CCJA, EJA Flangeless inner ring, guide ring centred on the outer ring raceway, two stamped steel cages
- E Optimized internal design for increased load carrying capacity
 213, 222 and 223 series: Flangeless inner ring and two stamped steel cages. Annular groove and three lubrication holes in the outer ring.
 d ≤ 65 mm: Guide ring centred on the inner ring
 d > 65 mm: Guide ring centred on the cage

Group 2: External design (seals, snap ring groove, etc.)

- CS, -2CS Contact seal, NBR, on one or both sides
- CS2, -2CS2 Contact seal, FKM, on one or both sides
- CS5, -2CS5 Contact seal, HNBR, on one or both sides
- RS, -2RS Contact seal, NBR, on one or both sides
- RS5, -2RS5 Contact seal, HNBR, on one or both sides
- K Tapered bore, taper 1:12
- K30 Tapered bore, taper 1:30

Group 3: Cage design

- F Machined steel cage, inner ring centred
- FA Machined steel cage, outer ring centred
- J Stamped steel cage, inner ring centred
- JA Stamped steel cage, outer ring centred
- MA Machined brass cage, outer ring centred



Group 4					
4.1	4.2	4.3	4.4	4.5	4.6

Group 4.6: Other variants

R505	Bearing for railway axleboxes
VA405	Bearing for vibratory applications, surface-hardened stamped steel cages
VA406	Same as VA405, and PTFE coated cylindrical inner ring bore
VA991	Bearing for high-speed applications
VE552(E)	Outer ring with three equally-spaced threaded holes in one side face to accommodate lifting tackle. The E indicates that appropriate eye bolts are supplied with the bearing.
VE553(E)	Same as VE552(E), but threaded holes in both side faces
VG114	Surface-hardened stamped steel cages
VQ424	Running accuracy better than C08

Group 4.5: Lubrication

GEM9	Filled to 70 – 100% with SKF LGHB 2 grease
GLE	Filled to 25 – 45% with SKF LGWM 2 grease
VT143	Filled to 25 – 45% with SKF LGEP 2 grease
VT143B	Filled to 45 – 60% with SKF LGEP 2 grease
VT143C	Filled to 70 – 100% with SKF LGEP 2 grease
W64	Solid Oil
W	Without annular groove and lubrication holes in the outer ring
W20	Three lubrication holes in the outer ring
W26	Six lubrication holes in the inner ring
W33	Annular groove and three lubrication holes in the outer ring
W33X	Annular groove and six lubrication holes in the outer ring
W77	Plugged W33 lubrication holes
W513	W26 + W33

Group 4.4: Stabilization**Group 4.3: Bearing sets, matched bearings****Group 4.2: Accuracy, clearance, preload, quiet running**

C08	Running accuracy to P5 tolerance class
C083	C08 + C3
C084	C08 + C4
C2	Radial internal clearance smaller than Normal
C3	Radial internal clearance greater than Normal
C4	Radial internal clearance greater than C3
C5	Radial internal clearance greater than C4
P5	Dimensional and running accuracy to P5 tolerance class
P6	Dimensional and running accuracy to P6 tolerance class
P62	P6 + C2

Group 4.1: Materials, heat treatment

235220	Case-hardened inner ring with a helical groove in the bore
HA3	Case-hardened inner ring



9.1 Spherical roller bearings

d 20 – 55 mm

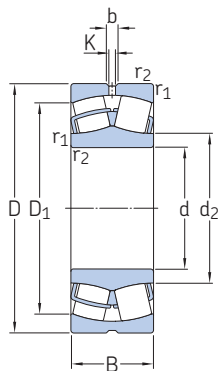

Cylindrical bore

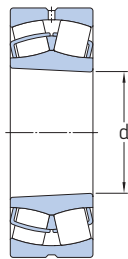

Tapered bore



Sealed (2RS)

Principal dimensions			Basic load ratings		Fatigue load limit P_u	Speed ratings		Mass	Designations	
d	D	B	dynamic	static		Reference speed	Limiting speed		Bearing with cylindrical bore	tapered bore
mm			kN		kN	r/min	kg	–		
20	52	18	49,9	44	4,75	13 000	17 000	0,28	22205/20 E	–
25	52	18	49,9	44	4,75	13 000	17 000	0,26	▶ 22205 E	▶ 22205 EK
	52	23	49,9	44	4,75	–	6 100	0,26	▶ BS2-2205-2RS/VT143	–
	62	17	49,1	41,5	4,55	9 300	12 000	0,28	21305 CC	–
30	62	20	66,1	60	6,4	10 000	14 000	0,29	▶ 22206 E	▶ 22206 EK
	62	25	66,1	60	6,4	–	5 100	0,34	▶ BS2-2206-2RS/VT143	–
	72	19	65,7	61	6,8	8 200	10 000	0,41	21306 CC	–
35	72	23	88,8	85	9,3	9 000	12 000	0,45	▶ 22207 E	▶ 22207 EK
	72	28	88,8	85	9,3	–	4 300	0,52	▶ BS2-2207-2RS/VT143	–
	80	21	79,2	72	8,15	7 300	9 500	0,55	21307 CC	–
40	80	23	98,5	90	9,8	8 000	11 000	0,53	▶ 22208 E	▶ 22208 EK
	80	28	98,5	90	9,8	–	3 900	0,57	▶ BS2-2208-2RS/VT143	▶ BS2-2208-2RSK/VT143
	90	23	107	108	11,8	7 000	9 500	0,75	▶ 21308 E	21308 EK
	90	33	155	140	15	6 000	8 000	1,05	▶ 22308 E/VA405	–
	90	33	155	140	15	6 000	8 000	1,05	▶ 22308 E	▶ 22308 EK
45	90	38	155	140	15	–	3 900	1,2	▶ BS2-2308-2RS/VT143	–
	85	23	104	98	10,8	7 500	10 000	0,58	▶ 22209 E	▶ 22209 EK
	85	28	104	98	10,8	–	3 500	0,66	▶ BS2-2209-2RS/VT143	▶ BS2-2209-2RSK/VT143
	100	25	129	127	13,7	6 300	8 500	0,99	21309 E	▶ 21309 EK
	100	36	190	183	19,6	5 300	7 000	1,4	▶ 22309 E/VA405	–
	100	36	190	183	19,6	5 300	7 000	1,4	▶ 22309 E	▶ 22309 EK
50	100	42	190	183	19,6	–	3 400	1,6	▶ BS2-2309-2RS/VT143	–
	90	23	107	108	11,8	7 000	9 500	0,63	▶ 22210 E	▶ 22210 EK
	90	28	107	108	11,8	–	3 200	0,7	▶ BS2-2210-2RS/VT143	▶ BS2-2210-2RSK/VT143
	110	27	159	166	18,6	5 600	7 500	1,35	▶ 21310 E	▶ 21310 EK
	110	40	228	224	24	4 800	6 300	1,9	▶ 22310 E/VA405	–
	110	40	228	224	24	4 800	6 300	1,9	▶ 22310 E	▶ 22310 EK
55	110	45	228	224	24	–	3 000	2,1	▶ BS2-2310-2RS/VT143	–
	100	25	129	127	13,7	6 300	8 500	0,84	▶ 22211 E	▶ 22211 EK
	100	31	129	127	13,7	–	2 900	1	▶ BS2-2211-2RS/VT143	▶ BS2-2211-2RSK/VT143
	120	29	159	166	18,6	5 600	7 500	1,7	▶ 21311 E	▶ 21311 EK
	120	43	280	280	30	4 300	5 600	2,45	▶ 22311 E	▶ 22311 EK
	120	43	280	280	30	4 300	5 600	2,45	▶ 22311 E/VA405	▶ 22311 EK/VA405
	120	49	280	280	30	–	2 800	2,8	▶ BS2-2311-2RS/VT143	–

SKF Explorer bearing

▶ Popular item

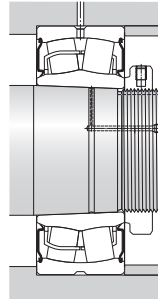
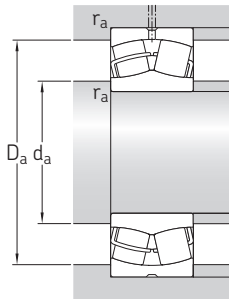

Dimensions					Abutment and fillet dimensions					Calculation factors				Permissible acceleration for oil lubrication ¹⁾	
d	d ₂ ≈	D ₁ ≈	b	K	r _{1,2} min.	d _a min.	d _a max.	D _a max.	r _a max.	e	Y ₁	Y ₂	Y ₀	rota- tional	linear
mm						mm				-				m/s ²	
20	31,3	44,2	3,7	2	1	25,6	-	46,4	1	0,35	1,9	2,9	1,8	-	-
25	31,3	44,2	3,7	2	1	30,6	-	46,4	1	0,35	1,9	2,9	1,8	-	-
	30	46,6	4,4	2	1	30	30	46,4	1	0,35	1,9	2,9	1,8	-	-
	35,7	50,7	-	-	1,1	32	-	55	1	0,3	2,3	3,4	2,2	-	-
30	37,6	53	3,7	2	1	35,6	-	56,4	1	0,31	2,2	3,3	2,2	-	-
	35,8	56,4	4,4	2	1	35,5	35,5	56,4	1	0,31	2,2	3,3	2,2	-	-
	43,3	58,8	-	-	1,1	37	-	65	1	0,27	2,5	3,7	2,5	-	-
35	44,5	61,8	3,7	2	1,1	42	-	65	1	0,31	2,2	3,3	2,2	-	-
	42,4	65,3	4,4	2	1,1	42	42	65	1	0,31	2,2	3,3	2,2	-	-
	47,2	65,6	-	-	1,5	44	-	71	1,5	0,28	2,4	3,6	2,5	-	-
40	49,6	69,4	6	3	1,1	47	-	73	1	0,28	2,4	3,6	2,5	-	-
	47,2	72,8	6	3	1,1	47	47	73	1	0,28	2,4	3,6	2,5	-	-
	60	79,8	5,5	3	1,5	49	-	81	1,5	0,24	2,8	4,2	2,8	-	-
45	49,9	74,3	6	3	1,5	49	-	81	1,5	0,37	1,8	2,7	1,8	115 g	31 g
	49,9	74,3	6	3	1,5	49	-	81	1,5	0,37	1,8	2,7	1,8	-	-
	47,5	79,3	6	3	1,5	47,5	47,5	81	1,5	0,37	1,8	2,7	1,8	-	-
	54,4	74,4	5,5	3	1,1	52	-	78	1	0,26	2,6	3,9	2,5	-	-
	52,5	77,8	6	3	1,1	52	52	78	1	0,26	2,6	3,9	2,5	-	-
	65,3	88	6	3	1,5	54	-	91	1,5	0,24	2,8	4,2	2,8	-	-
50	57,6	83,4	6	3	1,5	54	-	91	1,5	0,37	1,8	2,7	1,8	97 g	29 g
	57,6	83,4	6	3	1,5	54	-	91	1,5	0,37	1,8	2,7	1,8	-	-
	55	88,5	6	3	1,5	54	55	91	1,5	0,37	1,8	2,7	1,8	-	-
55	60	79	5,5	3	1,1	57	-	83	1	0,24	2,8	4,2	2,8	-	-
	58,1	82,3	6	3	1,1	57	58	83	1	0,24	2,8	4,2	2,8	-	-
	72,7	96,8	6	3	2	61	-	99	2	0,24	2,8	4,2	2,8	-	-
55	63,9	91,9	6	3	2	61	-	99	2	0,37	1,8	2,7	1,8	85 g	28 g
	63,9	91,9	6	3	2	61	-	99	2	0,37	1,8	2,7	1,8	-	-
	61,5	96,8	6	3	2	61	61	99	2	0,37	1,8	2,7	1,8	-	-
	65,3	88	6	3	1,5	64	-	91	1,5	0,24	2,8	4,2	2,8	-	-
	63,5	92	6	3	1,5	63,5	63,5	91	1,5	0,24	2,8	4,2	2,8	-	-
	72,7	96,2	6	3	2	66	-	109	2	0,24	2,8	4,2	2,8	-	-
55	70,1	102	5,5	3	2	66	-	109	2	0,35	1,9	2,9	1,8	-	-
	70,1	102	5,5	3	2	66	-	109	2	0,35	1,9	2,9	1,8	78 g	26 g
	67,5	107	6	3	2	66	67	109	2	0,35	1,9	2,9	1,8	-	-

¹⁾ For details about permissible accelerations → [page 779](#)



9.1 Spherical roller bearings

d 60 – 80 mm

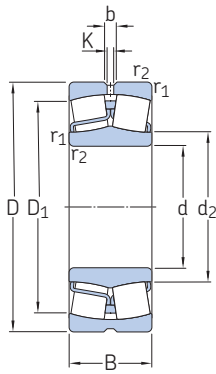

Cylindrical bore

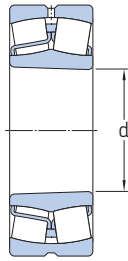

Tapered bore



Sealed (2RS, 2RS5)

Principal dimensions			Basic load ratings		Fatigue load limit P_u	Speed ratings		Mass	Designations	
d	D	B	dynamic C	static C_0		Reference speed	Limiting speed		Bearing with cylindrical bore	tapered bore
mm			kN		kN	r/min	kg	–		
60	110	28	159	166	18,6	5 600	7 500	1,15	▶ 22212 E	▶ 22212 EK
	110	34	159	166	18,6	–	2 700	1,3	▶ BS2-2212-2RS/VT143	▶ BS2-2212-2RSK/VT143
	130	31	217	240	26,5	4 800	6 300	2,1	▶ 21312 E	▶ 21312 EK
	130	46	325	335	36	4 000	5 300	3,1	▶ 22312 E	▶ 22312 EK
	130	46	325	335	36	4 000	5 300	3,1	▶ 22312 E/VA405	▶ 22312 EK/VA405
	130	53	325	335	36	–	2 500	3,4	▶ BS2-2312-2RS/VT143	–
65	100	35	137	173	20,4	–	2 600	0,95	24013-2RS5W/VT143	–
	100	35	137	173	20,4	4 300	6 300	0,95	24013 CC/W33	24013 CCK30/W33
	120	31	198	216	24	5 000	7 000	1,55	▶ 22213 E	▶ 22213 EK
	120	38	198	216	24	–	2 400	1,6	▶ BS2-2213-2RS/VT143	▶ BS2-2213-2RSK/VT143
	140	33	243	270	29	4 300	6 000	2,55	▶ 21313 E	▶ 21313 EK
	140	48	357	360	38	3 800	5 000	3,75	▶ 22313 E	▶ 22313 EK
	140	48	357	360	38	3 800	5 000	3,75	▶ 22313 E/VA405	22313 EK/VA405
	140	56	357	360	38	–	2 400	4,15	▶ BS2-2313-2RS/VT143	–
	125	31	213	228	25,5	5 000	6 700	1,55	▶ 22214 E	▶ 22214 EK
	125	38	213	228	25,5	–	2 300	1,8	▶ BS2-2214-2RS/VT143	▶ BS2-2214-2RSK/VT143
70	150	35	291	325	34,5	4 000	5 600	3,1	▶ 21314 E	▶ 21314 EK
	150	51	413	430	45	3 400	4 500	4,55	▶ 22314 E	▶ 22314 EK
	150	51	413	430	45	3 400	4 500	4,55	▶ 22314 E/VA405	▶ 22314 EK/VA405
	150	60	413	430	45	–	2 100	5,1	▶ BS2-2314-2RS/VT143	–
	115	40	181	232	28,5	–	2 300	1,55	24015-2RS5/VT143	–
	115	40	181	232	28,5	3 800	5 300	1,55	▶ 24015 CC/W33	24015 CCK30/W33
75	130	31	217	240	26,5	4 800	6 300	1,7	▶ 22215 E	▶ 22215 EK
	130	38	217	240	26,5	–	2 200	2,1	▶ BS2-2215-2RS/VT143	▶ BS2-2215-2RSK/VT143
	160	37	291	325	34,5	4 000	5 600	3,75	▶ 21315 E	▶ 21315 EK
	160	55	462	475	48	3 200	4 300	5,55	▶ 22315 E	▶ 22315 EK
	160	55	462	475	48	3 200	4 300	5,55	▶ 22315 EJA/VA405	22315 EKJA/VA405
	160	64	462	475	48	–	2 100	6,5	▶ BS2-2315-2RS/VT143	▶ BS2-2315-2RSK/VT143
	140	33	243	270	29	4 300	6 000	2,1	▶ 22216 E	▶ 22216 EK
	140	40	243	270	29	–	2 000	2,4	▶ BS2-2216-2RS/VT143	▶ BS2-2216-2RSK/VT143
	170	39	331	375	39	3 800	5 300	4,45	▶ 21316 E	▶ 21316 EK
	170	58	516	530	54	3 000	4 000	6,6	▶ 22316 E	▶ 22316 EK
80	170	58	516	530	54	3 000	4 000	6,6	▶ 22316 EJA/VA405	22316 EKJA/VA405
	170	67	516	530	54	–	2 000	7,2	▶ BS2-2316-2RS/VT143	–

SKF Explorer bearing

▶ Popular item

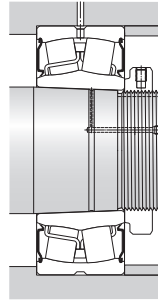
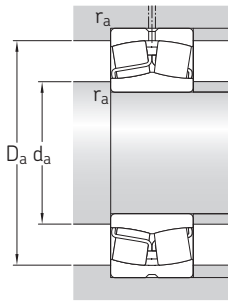

Dimensions					Abutment and fillet dimensions					Calculation factors				Permissible acceleration for oil lubrication ¹⁾	
d	d ₂ ≈	D ₁ ≈	b	K	r _{1,2} min.	d _a min.	d _a max.	D _a max.	r _a max.	e	Y ₁	Y ₂	Y ₀	rota- tional	linear
mm						mm				-				m/s ²	
60	72,7	96,5	6	3	1,5	69	-	101	1,5	0,24	2,8	4,2	2,8	-	-
	69,7	101	6	3	1,5	69	69	101	1,5	0,24	2,8	4,2	2,8	-	-
	87,8	115	6	3	2,1	72	-	118	2	0,22	3	4,6	2,8	-	-
	77,9	110	8,3	4,5	2,1	72	-	118	2	0,35	1,9	2,9	1,8	-	-
	77,9	110	8,3	4,5	2,1	72	-	118	2	0,35	1,9	2,9	1,8	70 g	25 g
	75	117	8,3	4,5	2,1	72	75	118	2	0,35	1,9	2,9	1,8	-	-
65	71,6	93,5	-	-	1,1	71	71	94	1	0,27	2,5	3,7	2,5	-	-
	73,9	87,3	3,7	2	1,1	71	-	94	1	0,27	2,5	3,7	2,5	-	-
	80,1	106	6	3	1,5	74	-	111	1,5	0,24	2,8	4,2	2,8	-	-
	76,5	110	6	3	1,5	74	76	111	1,5	0,24	2,8	4,2	2,8	-	-
	94,7	124	6	3	2,1	77	-	128	2	0,22	3	4,6	2,8	-	-
	81,6	118	8,3	4,5	2,1	77	-	128	2	0,35	1,9	2,9	1,8	-	-
	81,6	118	8,3	4,5	2,1	77	-	128	2	0,35	1,9	2,9	1,8	69 g	24 g
	78,7	125	8,3	4,5	2,1	77	78	128	2	0,35	1,9	2,9	1,8	-	-
70	83	111	6	3	1,5	79	-	116	1,5	0,23	2,9	4,4	2,8	-	-
	80,1	116	6	3	1,5	79	80	116	1,5	0,23	2,9	4,4	2,8	-	-
	101	133	6	3	2,1	82	-	138	2	0,22	3	4,6	2,8	-	-
	90,3	128	8,3	4,5	2,1	82	-	138	2	0,33	2	3	2	-	-
	90,3	128	8,3	4,5	2,1	82	-	138	2	0,33	2	3	2	61 g	23 g
	86,7	136	8,3	4,5	2,1	82	86	138	2	0,33	2	3	2	-	-
75	81,8	106	6	3	1,1	81	81	109	1	0,28	2,4	3,6	2,5	-	-
	84,2	100	5,5	3	1,1	81	-	109	1	0,28	2,4	3,6	2,5	-	-
	87,8	115	6	3	1,5	84	-	121	1,5	0,22	3	4,6	2,8	-	-
	84,5	120	6	3	1,5	84	84	121	1,5	0,22	3	4,6	2,8	-	-
	101	133	6	3	2,1	87	-	148	2	0,22	3	4,6	2,8	-	-
	92,8	135	8,3	4,5	2,1	87	-	148	2	0,35	1,9	2,9	1,8	-	-
	92,8	135	8,3	4,5	2,1	87	-	148	2	0,35	1,9	2,9	1,8	88 g	23 g
	89,9	140	8,3	4,5	2,1	87	89	148	2	0,35	1,9	2,9	1,8	-	-
80	94,7	124	6	3	2	91	-	129	2	0,22	3	4,6	2,8	-	-
	91,7	129	6	3	2	91	91	129	2	0,22	3	4,6	2,8	-	-
	106	141	6	3	2,1	92	-	158	2	0,24	2,8	4,2	2,8	-	-
	98,3	143	8,3	4,5	2,1	92	-	158	2	0,35	1,9	2,9	1,8	-	-
	98,3	143	8,3	4,5	2,1	92	-	158	2	0,35	1,9	2,9	1,8	80 g	22 g
	94,2	150	8,3	4,5	2,1	92	94	158	2	0,35	1,9	2,9	1,8	-	-

¹⁾ For details about permissible accelerations → [page 779](#)



9.1 Spherical roller bearings

d 85 – 100 mm

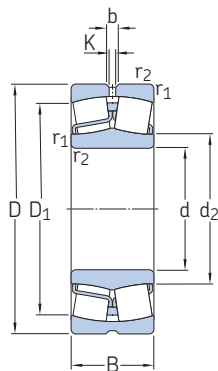

Cylindrical bore

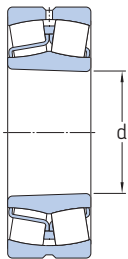

Tapered bore



Sealed (2RS, 2RS5)

Principal dimensions			Basic load ratings		Fatigue load limit P_u	Speed ratings		Mass	Designations	
d	D	B	dynamic C	static C_0		Reference speed	Limiting speed		Bearing with cylindrical bore	tapered bore
mm			kN		kN	r/min	kg	–		
85	150	36	291	325	34,5	4 000	5 600	2,7	▶ 22217 E	▶ 22217 EK
	150	44	291	325	34,5	–	1 900	3	▶ BS2-2217-2RS/VT143	▶ BS2-2217-2RSK/VT143
	180	41	331	375	39	3 800	5 300	5,2	▶ 21317 E	▶ 21317 EK
	180	60	577	620	61	2 800	3 800	7,65	▶ 22317 E	▶ 22317 EK
	180	60	577	620	61	2 800	3 800	7,65	▶ 22317 EJA/VA405	▶ 22317 EKJA/VA405
	180	60	577	620	61	2 800	3 800	7,65	▶ 22317 EJA/VA406	–
90	160	40	331	375	39	3 800	5 300	3,4	▶ 22218 E	▶ 22218 EK
	160	48	331	375	39	–	1 800	3,7	▶ BS2-2218-2RS/VT143	▶ BS2-2218-2RSK/VT143
	160	52,4	372	440	48	2 800	3 800	4,65	▶ 23218 CC/W33	▶ 23218 CCK/W33
	190	43	393	450	45,5	3 600	4 800	6,1	▶ 21318 E	▶ 21318 EK
	190	64	637	695	67	2 600	3 600	9,05	▶ 22318 E	▶ 22318 EK
	190	64	637	695	67	2 600	3 600	9,05	▶ 22318 EJA/VA405	▶ 22318 EKJA/VA405
95	190	73	637	695	67	–	1 700	9,8	▶ BS2-2318-2RS5/VT143	▶ BS2-2318-2RS5K/VT143
	170	43	393	450	45,5	3 600	4 800	4,15	▶ 22219 E	▶ 22219 EK
	170	51	393	450	45,5	–	1 700	4,65	▶ BS2-2219-2RS/VT143	–
	200	45	433	490	49	3 400	4 500	7,05	▶ 21319 E	▶ 21319 EK
	200	67	699	765	73,5	2 600	3 400	10,5	▶ 22319 E	▶ 22319 EK
	200	67	699	765	73,5	2 600	3 400	10,5	▶ 22319 EJA/VA405	▶ 22319 EKJA/VA405
100	150	50	296	415	45,5	–	1 700	3,15	▶ 24020-2RS5/VT143	–
	150	50	296	415	45,5	2 800	4 000	3,15	▶ 24020 CC/W33	▶ 24020 CCK30/W33
	165	52	385	490	53	3 000	4 000	4,55	▶ 23120 CC/W33	▶ 23120 CCK/W33
	165	52	386	490	53	–	1 700	4,55	▶ 23120-2RS5/VT143	–
	165	65	468	640	68	2 400	3 200	5,65	▶ 24120 CC/W33	▶ 24120 CCK30/W33
	165	65	470	640	68	–	1 700	5,65	▶ 24120-2RS5/VT143	–
	180	46	433	490	49	3 400	4 500	4,9	▶ 22220 E	▶ 22220 EK
	180	55	433	490	49	–	1 600	5,5	▶ BS2-2220-2RS5/VT143	▶ BS2-2220-2RS5K/VT143
	180	60,3	498	600	63	2 400	3 400	6,85	▶ 23220 CC/W33	▶ 23220 CCK/W33
	180	60,3	499	600	63	–	1 600	6,85	▶ 23220-2RS/VT143	–
	180	60,3	499	600	63	–	1 600	6,85	▶ 23220-2RS5/VT143	–
	215	47	433	490	49	3 400	4 500	8,6	▶ 21320 E	▶ 21320 EK
	215	73	847	950	88	2 400	3 000	13,5	▶ 22320 E	▶ 22320 EK
	215	73	847	950	88	2 400	3 000	13,5	▶ 22320 EJA/VA405	▶ 22320 EKJA/VA405
	215	73	847	950	88	2 400	3 000	13,5	▶ 22320 EJA/VA406	–

SKF Explorer bearing

▶ Popular item

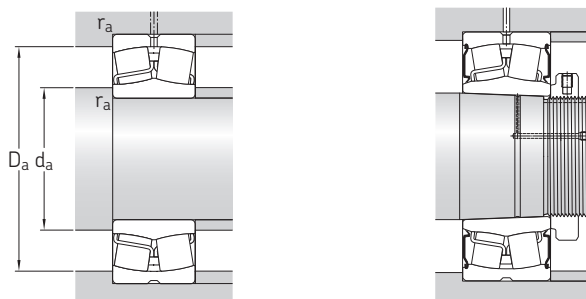

Dimensions						Abutment and fillet dimensions				Calculation factors				Permissible acceleration for oil lubrication ¹⁾	
d	d ₂ ≈	D ₁ ≈	b	K	r _{1,2} min.	d _a min.	d _a max.	D _a max.	r _a max.	e	Y ₁	Y ₂	Y ₀	rota- tional	linear
mm						mm				-				m/s ²	
85	101	133	6	3	2	96	-	139	2	0,22	3	4,6	2,8	-	-
	98,2	137	6	3	2	96	98	139	2	0,22	3	4,6	2,8	-	-
	106	141	6	3	3	99	-	166	2,5	0,24	2,8	4,2	2,8	-	-
	108	154	8,3	4,5	3	99	-	166	2,5	0,33	2	3	2	-	-
	108	154	8,3	4,5	3	99	-	166	2,5	0,33	2	3	2	74 g	21 g
	108	154	8,3	4,5	3	99	-	166	2,5	0,33	2	3	2	74 g	21 g
90	106	141	6	3	2	101	-	149	2	0,24	2,8	4,2	2,8	-	-
	102	146	6	3	2	101	102	149	2	0,24	2,8	4,2	2,8	-	-
	106	137	5,5	3	2	101	-	149	2	0,31	2,2	3,3	2,2	-	-
	112	150	8,3	4,5	3	104	-	176	2,5	0,24	2,8	4,2	2,8	-	-
	113	161	11,1	6	3	104	-	176	2,5	0,33	2	3	2	-	-
	113	161	11,1	6	3	104	-	176	2,5	0,33	2	3	2	68 g	21 g
109	165	11,1	6	3	104	109	176	2,5	0,33	2	3	2	-	-	
95	112	150	8,3	4,5	2,1	107	-	158	2	0,24	2,8	4,2	2,8	-	-
	109	155	8,3	4,5	2,1	107	109	158	2	0,24	2,8	4,2	2,8	-	-
	118	159	8,3	4,5	3	109	-	186	2,5	0,24	2,8	4,2	2,8	-	-
	118	168	11,1	6	3	109	-	186	2,5	0,33	2	3	2	-	-
	118	168	11,1	6	3	109	-	186	2,5	0,33	2	3	2	64 g	20 g
	118	168	11,1	6	3	109	-	186	2,5	0,33	2	3	2	-	-
100	108	138	6	3	1,5	107	108	143	1,5	0,28	2,4	3,6	2,5	-	-
	111	132	6	3	1,5	107	-	143	1,5	0,28	2,4	3,6	2,5	-	-
	115	144	6	3	2	111	-	154	2	0,3	2,3	3,4	2,2	-	-
	112	149	6	3	2	111	112	154	2	0,27	2,5	3,7	2,5	-	-
	113	141	4,4	2	2	111	-	154	2	0,37	1,8	2,7	1,8	-	-
	110	147	4,4	2	2	110	110	154	2	0,35	1,9	2,9	1,8	-	-
	118	159	8,3	4,5	2,1	112	-	168	2	0,24	2,8	4,2	2,8	-	-
	114	163	8,3	4,5	2,1	112	114	168	2	0,24	2,8	4,2	2,8	-	-
	117	153	8,3	4,5	2,1	112	-	168	2	0,33	2	3	2	-	-
	114	159	8,3	4,5	2,1	112	114	168	2	0,3	2,3	3,4	2,2	-	-
	114	159	8,3	4,5	2,1	112	114	168	2	0,3	2,3	3,4	2,2	-	-
	118	159	8,3	4,5	3	114	-	201	2,5	0,24	2,8	4,2	2,8	-	-
	130	184	11,1	6	3	114	-	201	2,5	0,33	2	3	2	-	-
	130	184	11,1	6	3	114	-	201	2,5	0,33	2	3	2	56 g	20 g
	130	184	11,1	6	3	114	-	201	2,5	0,33	2	3	2	56 g	20 g

¹⁾ For details about permissible accelerations → [page 779](#)

9.1 Spherical roller bearings

d 110 – 120 mm

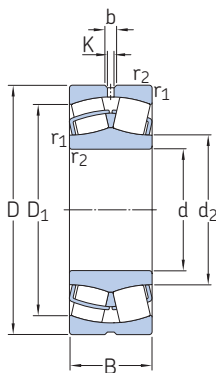

Cylindrical bore

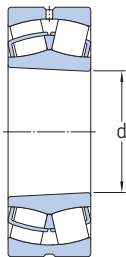

Tapered bore

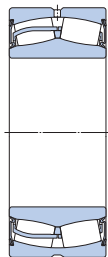

Sealed (2RS, 2RS5, 2CS5)

Principal dimensions			Basic load ratings		Fatigue load limit P_u	Speed ratings		Mass	Designations	
d	D	B	dynamic C	static C_0		Reference speed	Limiting speed		Bearing with cylindrical bore	tapered bore
mm			kN		kN	r/min	kg	–		
110	170	45	326	440	46,5	–	1 500	3,8	▶ 23022-2RS/VT143	–
	170	45	326	440	46,5	3 400	4 300	3,8	▶ 23022 CC/W33	▶ 23022 CCK/W33
	170	60	437	620	67	2 400	3 600	5	▶ 24022 CC/W33	▶ 24022 CCK30/W33
	170	60	438	620	67	–	1 600	5	▶ 24022-2RS5/VT143	–
	180	56	450	585	61	2 800	3 600	5,75	▶ 23122 CC/W33	▶ 23122 CCK/W33
	180	56	451	585	61	–	800	5,75	▶ 23122-2CS5/VT143	▶ 23122-2CS5K/VT143
	180	69	539	750	78	2 000	3 000	7,1	▶ 24122 CC/W33	▶ 24122 CCK30/W33
	180	69	540	750	78	–	630	7,1	▶ 24122-2CS5/VT143	–
	200	53	572	640	63	3 000	4 000	7	▶ 22222 E	▶ 22222 EK
	200	63	572	640	63	–	1 500	7,6	▶ BS2-2222-2RS5/VT143	▶ BS2-2222-2RS5K/VT143
	200	69,8	626	765	76,5	2 200	3 200	9,85	▶ 23222 CC/W33	▶ 23222 CCK/W33
	200	69,8	627	765	76,5	–	640	9,85	▶ 23222-2CS5/VT143	▶ 23222-2CS5K/VT143
120	240	80	989	1 120	100	2 000	2 800	18,5	▶ 22322 E	▶ 22322 EK
	240	80	989	1 120	100	2 000	2 800	18,5	▶ 22322 EJA/VA405	▶ 22322 EKJA/VA405
	240	80	989	1 120	100	2 000	2 800	18,5	▶ 22322 EJA/VA406	–
	180	46	366	500	52	3 200	4 000	4,2	▶ 23024 CC/W33	▶ 23024 CCK/W33
	180	46	367	500	52	–	1 400	4,2	▶ 23024-2RS5/VT143	–
	180	60	456	670	68	2 400	3 400	5,45	▶ 24024 CC/W33	▶ 24024 CCK30/W33
	180	60	457	670	68	–	670	5,45	▶ 24024-2CS5/VT143	–
	200	62	534	695	71	2 600	3 400	8	▶ 23124 CC/W33	▶ 23124 CCK/W33
	200	62	535	695	71	–	720	7,55	▶ 23124-2CS5/VT143	–
	200	80	679	950	95	1 900	2 600	10,5	▶ 24124 CC/W33	▶ 24124 CCK30/W33
	200	80	680	950	95	–	560	10,5	▶ 24124-2CS5/VT143	–
	215	58	652	765	73,5	2 800	3 800	8,7	▶ 22224 E	▶ 22224 EK
	215	69	652	765	73,5	–	1 400	9,75	▶ BS2-2224-2RS5/VT143	▶ BS2-2224-2RS5K/VT143
	215	76	732	930	93	2 000	2 800	12	▶ 23224 CC/W33	▶ 23224 CCK/W33
	215	76	734	930	93	–	600	12	▶ 23224-2CS5/VT143	▶ 23224-2CS5K/VT143
	260	86	1 019	1 120	100	2 000	2 600	23	▶ 22324 CC/W33	▶ 22324 CCK/W33
	260	86	1 019	1 120	100	2 000	2 600	23	▶ 22324 CCJA/W33VA405	▶ 22324 CCKJA/W33VA405
	260	86	1 019	1 120	100	2 000	2 600	23	▶ 22324 CCJA/W33VA406	–
260	86	1 022	1 120	100	–	600	23	▶ 22324-2CS5/VT143	▶ 22324-2CS5K/VT143	

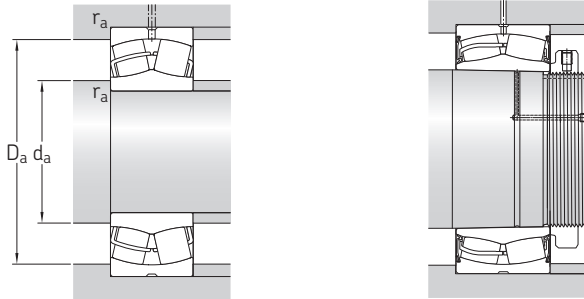

Dimensions					Abutment and fillet dimensions					Calculation factors				Permissible acceleration for oil lubrication ¹⁾	
d	d ₂ ≈	D ₁ ≈	b	K	r _{1,2} min.	d _a min.	d _a max.	D _a max.	r _a max.	e	Y ₁	Y ₂	Y ₀	rota- tional	linear
mm						mm				–				m/s ²	
110	122	156	6	3	2	119	122	161	2	0,21	3,2	4,8	3,2	–	–
	125	151	6	3	2	119	–	161	2	0,23	2,9	4,4	2,8	–	–
	122	149	5,5	3	2	119	–	161	2	0,33	2	3	2	–	–
	120	154	6	3	2	119	120	161	2	0,3	2,3	3,4	2,2	–	–
	126	157	8,3	4,5	2	121	–	169	2	0,3	2,3	3,4	2,2	–	–
	122	166	8,3	4,5	2	121	122	169	2	0,27	2,5	3,7	2,5	–	–
	123	153	6	3	2	121	–	169	2	0,37	1,8	2,7	1,8	–	–
	120	163	6	3	2	121	121	169	2	0,35	1,9	2,9	1,8	–	–
	130	178	8,3	4,5	2,1	122	–	188	2	0,25	2,7	4	2,5	–	–
	126	183	8,3	4,5	2,1	122	126	188	2	0,25	2,7	4	2,5	–	–
	130	169	8,3	4,5	2,1	122	–	188	2	0,33	2	3	2	–	–
	126	178	8,3	4,5	2,1	122	126	188	2	0,33	2	3	2	–	–
	143	204	13,9	7,5	3	124	–	226	2,5	0,33	2	3	2	–	–
	143	204	13,9	7,5	3	124	–	226	2,5	0,33	2	3	2	53 g	19 g
	143	204	13,9	7,5	3	124	–	226	2,5	0,33	2	3	2	53 g	19 g
120	135	163	6	3	2	129	–	171	2	0,22	3	4,6	2,8	–	–
	132	168	6	3	2	129	132	171	2	0,2	3,4	5	3,2	–	–
	132	159	6	3	2	129	–	171	2	0,3	2,3	3,4	2,2	–	–
	130	166	6	3	2	129	130	171	2	0,28	2,4	3,6	2,5	–	–
	139	174	8,3	4,5	2	131	–	189	2	0,28	2,4	3,6	2,5	–	–
	135	183	8,3	4,5	2	131	135	189	2	0,27	2,5	3,7	2,5	–	–
	135	168	6	3	2	131	–	189	2	0,37	1,8	2,7	1,8	–	–
	132	179	6	3	2	131	132	189	2	0,37	1,8	2,7	1,8	–	–
	141	189	11,1	6	2,1	132	–	203	2	0,26	2,6	3,9	2,5	–	–
	136	194	11,1	6	2,1	132	136	203	2	0,26	2,6	3,9	2,5	–	–
	141	182	8,3	4,5	2,1	132	–	203	2	0,35	1,9	2,9	1,8	–	–
	137	193	8,3	4,5	2,1	132	137	203	2	0,33	2	3	2	–	–
	152	216	13,9	7,5	3	134	–	246	2,5	0,35	1,9	2,9	1,8	–	–
	152	216	13,9	7,5	3	134	–	246	2,5	0,35	1,9	2,9	1,8	96 g	21 g
	152	216	13,9	7,5	3	134	–	246	2,5	0,35	1,9	2,9	1,8	96 g	21 g
	147	229	13,9	7,5	3	134	147	246	2,5	0,33	2	3	2	–	–

¹⁾ For details about permissible accelerations → [page 779](#)



9.1 Spherical roller bearings

d 130 – 140 mm

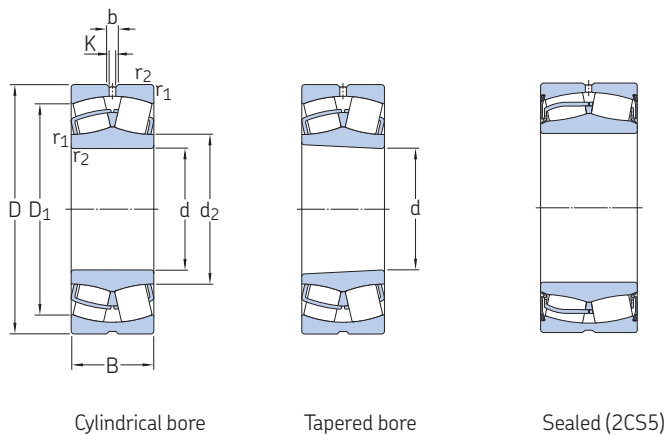

Cylindrical bore

Tapered bore

Sealed (2CS5)

Principal dimensions			Basic load ratings		Fatigue load limit P_u	Speed ratings		Mass	Designations	
d	D	B	dynamic C	static C_0		Reference speed	Limiting speed		Bearing with cylindrical bore	tapered bore
mm			kN		kN	r/min	kg	–		
130	200	52	452	610	61	2 800	3 600	6	▶ 23026 CC/W33	▶ 23026 CCK/W33
	200	52	452	610	62	–	800	6	▶ 23026-2CS5/VT143	▶ 23026-2CS5K/VT143
	200	69	569	815	81,5	2 000	3 000	8,05	▶ 24026 CC/W33	▶ 24026 CCK30/W33
	200	69	570	830	81,5	–	600	8,05	▶ 24026-2CS5/VT143	–
	210	64	586	780	78	2 400	3 200	8,8	▶ 23126 CC/W33	▶ 23126 CCK/W33
	210	80	699	1 000	100	1 700	2 400	11	▶ 24126 CC/W33	▶ 24126 CCK30/W33
	210	80	701	1 000	100	–	530	11	▶ 24126-2CS5/VT143	–
	220	73	640	930	93	1 600	2 400	11,5	▶ 229750 J/C3R505	–
	230	64	758	930	88	2 600	3 600	11	▶ 22226 E	▶ 22226 EK
	230	75	758	930	88	–	700	11	▶ BS2-2226-2CS5/VT143	▶ BS2-2226-2CS5K/VT143
	230	80	826	1 060	104	1 900	2 600	14,5	▶ 23226 CC/W33	▶ 23226 CCK/W33
	230	80	828	1 060	104	–	530	14,5	▶ 23226-2CS5/VT143	▶ 23226-2CS5K/VT143
	280	93	1 176	1 320	114	1 800	2 400	29	▶ 22326 CC/W33	▶ 22326 CCK/W33
	280	93	1 176	1 320	114	1 800	2 400	29	▶ 22326 CCJA/W33VA405	▶ 22326 CCKJA/W33VA405
	280	93	1 176	1 320	114	1 800	2 400	29	▶ 22326 CCJA/W33VA406	–
280	93	1 178	1 320	114	–	500	29	▶ 22326-2CS5/VT143	▶ 22326-2CS5K/VT143	
140	210	53	485	680	68	–	700	6,55	▶ 23028-2CS5/VT143	▶ 23028-2CS5K/VT143
	210	53	485	680	68	2 600	3 400	6,55	▶ 23028 CC/W33	▶ 23028 CCK/W33
	210	69	600	900	88	2 000	2 800	8,55	▶ 24028 CC/W33	▶ 24028 CCK30/W33
	210	69	601	900	88	–	560	8,55	▶ 24028-2CS5/VT143	–
	225	68	659	900	88	2 200	2 800	10,5	▶ 23128 CC/W33	▶ 23128 CCK/W33
	225	85	796	1 160	112	1 600	2 200	13,5	▶ 24128 CC/W33	▶ 24128 CCK30/W33
	225	85	797	1 160	112	–	450	13,5	▶ 24128-2CS5/VT143	▶ 24128-2CS5K30/VT143
	250	68	743	900	86,5	2 400	3 200	14	▶ 22228 CC/W33	▶ 22228 CCK/W33
	250	68	744	900	86,5	–	670	14	▶ 22228-2CS5/VT143	▶ 22228-2CS5K/VT143
	250	88	962	1 250	120	1 700	2 400	19	▶ 23228 CC/W33	▶ 23228 CCK/W33
	250	88	963	1 250	120	–	480	19	▶ 23228-2CS5/VT143	▶ 23228-2CS5K/VT143
	300	102	1 357	1 560	132	1 700	2 200	36,5	▶ 22328 CC/W33	▶ 22328 CCK/W33
	300	102	1 357	1 560	132	1 700	2 200	36,5	▶ 22328 CCJA/W33VA405	▶ 22328 CCKJA/W33VA405
	300	102	1 357	1 560	132	1 700	2 200	36,5	▶ 22328 CCJA/W33VA406	–
	300	102	1 359	1 560	132	–	430	36,5	▶ 22328-2CS5/VT143	▶ 22328-2CS5K/VT143

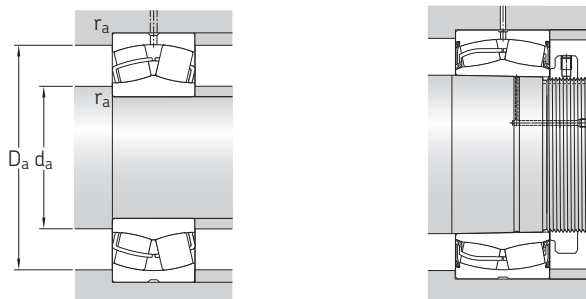

Dimensions					Abutment and fillet dimensions					Calculation factors				Permissible acceleration for oil lubrication ¹⁾	
d	d ₂	D ₁	b	K	r _{1,2}	d _a min.	d _a max.	D _a max.	r _a max.	e	Y ₁	Y ₂	Y ₀	rotational	linear
mm					mm					-				m/s ²	
130	148	180	8,3	4,5	2	139	-	191	2	0,23	2,9	4,4	2,8	-	-
	145	186	8,3	4,5	2	139	145	191	2	0,21	3,2	4,8	3,2	-	-
	145	175	6	3	2	139	-	191	2	0,31	2,2	3,3	2,2	-	-
	140	183	6	3	2	139	140	191	2	0,3	2,3	3,4	2,2	-	-
	148	184	8,3	4,5	2	141	-	199	2	0,28	2,4	3,6	2,5	-	-
	146	180	6	3	2	141	-	199	2	0,35	1,9	2,9	1,8	-	-
	141	190	6	3	2	141	141	199	2	0,33	2	3	2	-	-
	154	190	-	-	2,1	142	-	208	2	0,31	2,2	3,3	2,2	-	-
	152	201	11,1	6	3	144	-	216	2,5	0,27	2,5	3,7	2,5	-	-
	147	205	11,1	6	3	144	147	216	2,5	0,27	2,5	3,7	2,5	-	-
	151	196	8,3	4,5	3	144	-	216	2,5	0,33	2	3	2	-	-
	147	209	8,3	4,5	3	144	147	216	2,5	0,31	2,2	3,3	2,2	-	-
164	233	16,7	9	4	147	-	263	3	0,35	1,9	2,9	1,8	-	-	
164	233	16,7	9	4	147	-	263	3	0,35	1,9	2,9	1,8	87 g	20 g	
164	233	16,7	9	4	147	-	263	3	0,35	1,9	2,9	1,8	87 g	20 g	
159	246	16,7	9	4	147	159	263	3	0,33	2	3	2	-	-	
140	155	197	8,3	4,5	2	149	155	201	2	0,2	3,4	5	3,2	-	-
	158	190	8,3	4,5	2	149	-	201	2	0,22	3	4,6	2,8	-	-
	155	185	6	3	2	149	-	201	2	0,3	2,3	3,4	2,2	-	-
	151	195	6	3	2	149	151	201	2	0,28	2,4	3,6	2,5	-	-
	159	197	8,3	4,5	2,1	152	-	213	2	0,28	2,4	3,6	2,5	-	-
	156	193	8,3	4,5	2,1	152	-	213	2	0,35	1,9	2,9	1,8	-	-
	153	203	8,3	4,5	2,1	152	153	213	2	0,35	1,9	2,9	1,8	-	-
	166	216	11,1	6	3	154	-	236	2,5	0,26	2,6	3,9	2,5	-	-
	161	225	11,1	6	3	154	161	236	2,5	0,24	2,8	4,2	2,8	-	-
	165	212	11,1	6	3	154	-	236	2,5	0,33	2	3	2	-	-
	161	225	11,1	6	3	154	161	236	2,5	0,33	2	3	2	-	-
	175	247	16,7	9	4	157	-	283	3	0,35	1,9	2,9	1,8	-	-
175	247	16,7	9	4	157	-	283	3	0,35	1,9	2,9	1,8	78 g	20 g	
175	247	16,7	9	4	157	-	283	3	0,35	1,9	2,9	1,8	78 g	20 g	
169	261	16,7	9	4	157	169	283	3	0,33	2	3	2	-	-	

¹⁾ For details about permissible accelerations → [page 779](#)



9.1 Spherical roller bearings

d 150 – 160 mm

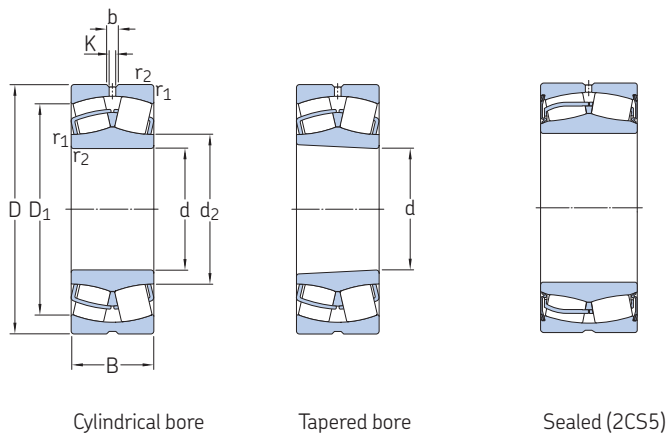

Principal dimensions			Basic load ratings		Fatigue load limit P_u	Speed ratings		Mass	Designations	
d	D	B	C	C_0		Reference speed	Limiting speed		Bearing with cylindrical bore	tapered bore
mm			kN		kN	r/min		kg	–	
150	225	56	531	750	73,5	2 400	3 200	7,95	▶ 23030 CC/W33	▶ 23030 CCK/W33
	225	56	532	750	73,5	–	670	7,95	▶ 23030-2CS5/VT143	▶ 23030-2CS5K/VT143
	225	75	680	1 040	100	1 800	2 600	10,5	▶ 24030 CC/W33	▶ 24030 CCK30/W33
	225	75	681	1 040	100	–	530	10,5	▶ 24030-2CS5/VT143	–
	250	80	883	1 200	114	2 000	2 600	16	▶ 23130 CC/W33	▶ 23130 CCK/W33
	250	80	884	1 200	114	–	560	16	▶ 23130-2CS5/VT143	▶ 23130-2CS5K/VT143
	250	100	1 054	1 530	146	1 400	2 000	20	▶ 24130 CC/W33	▶ 24130 CCK30/W33
	250	100	1 056	1 530	146	–	400	20	▶ 24130-2CS5/VT143	▶ 24130-2CS5K30/VT143
	270	73	898	1 080	102	2 200	3 000	18	▶ 22230 CC/W33	▶ 22230 CCK/W33
	270	73	899	1 080	102	–	630	18	▶ 22230-2CS5/VT143	▶ 22230-2CS5K/VT143
	270	96	1 129	1 460	137	1 600	2 200	24,5	▶ 23230 CC/W33	▶ 23230 CCK/W33
	270	96	1 132	1 460	137	–	430	24,5	▶ 23230-2CS5/VT143	▶ 23230-2CS5K/VT143
160	320	108	1 539	1 760	146	1 600	2 000	43,5	▶ 22330 CC/W33	▶ 22330 CCK/W33
	320	108	1 539	1 760	146	1 600	2 000	43,5	▶ 22330 CCJA/W33VA405	▶ 22330 CCKJA/W33VA405
	320	108	1 539	1 760	146	1 600	2 000	43,5	▶ 22330 CCJA/W33VA406	–
	320	108	1 541	1 760	146	–	400	43,5	▶ 22330-2CS5/VT143	▶ 22330-2CS5K/VT143
	240	60	614	880	83	2 400	3 000	9,7	▶ 23032 CC/W33	▶ 23032 CCK/W33
	240	60	615	880	83	–	670	9,7	▶ 23032-2CS5/VT143	▶ 23032-2CS5K/VT143
	240	80	783	1 200	114	1 700	2 400	13	▶ 24032 CC/W33	▶ 24032 CCK30/W33
	240	80	784	1 200	114	–	450	13	▶ 24032-2CS5/VT143	–
	270	86	1 029	1 370	129	1 900	2 400	20,5	▶ 23132 CC/W33	▶ 23132 CCK/W33
	270	86	1 030	1 400	129	–	530	20,5	▶ 23132-2CS5/VT143	▶ 23132-2CS5K/VT143
	270	109	1 227	1 760	163	1 300	1 900	25	▶ 24132 CC/W33	▶ 24132 CCK30/W33
	270	109	1 229	1 760	163	–	380	25	▶ 24132-2CS5/VT143	–
290	80	1 043	1 290	118	2 000	2 800	22,5	▶ 22232 CC/W33	▶ 22232 CCK/W33	
290	80	1 044	1 290	118	–	600	22,5	▶ 22232-2CS5/VT143	▶ 22232-2CS5K/VT143	
290	104	1 281	1 660	153	1 500	2 200	31	▶ 23232 CC/W33	▶ 23232 CCK/W33	
340	114	1 680	1 960	160	1 500	1 900	52	▶ 22332 CC/W33	▶ 22332 CCK/W33	
340	114	1 680	1 960	160	1 500	1 900	52	▶ 22332 CCJA/W33VA405	▶ 22332 CCKJA/W33VA405	
340	114	1 680	1 960	160	1 500	1 900	52	▶ 22332 CCJA/W33VA406	–	
340	114	1 683	1 960	160	–	380	52	▶ 22332-2CS5/VT143	▶ 22332-2CS5K/VT143	

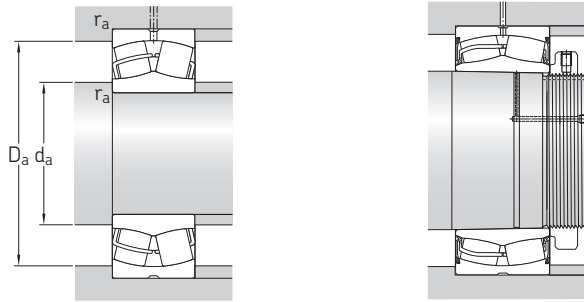

Dimensions					Abutment and fillet dimensions					Calculation factors				Permissible acceleration for oil lubrication ¹⁾	
d	d ₂ ≈	D ₁ ≈	b	K	r _{1,2} min.	d _a min.	d _a max.	D _a max.	r _a max.	e	Y ₁	Y ₂	Y ₀	rota- tional	linear
mm						mm				-				m/s ²	
150	169	203	8,3	4,5	2,1	161	-	214	2	0,22	3	4,6	2,8	-	-
	165	211	8,3	4,5	2,1	161	165	214	2	0,2	3,4	5	3,2	-	-
	165	197	6	3	2,1	161	-	214	2	0,3	2,3	3,4	2,2	-	-
	162	206	6	3	2,1	161	162	214	2	0,28	2,4	3,6	2,5	-	-
	172	216	11,1	6	2,1	162	-	238	2	0,3	2,3	3,4	2,2	-	-
	168	226	11,1	6	2,1	162	168	238	2	0,28	2,4	3,6	2,5	-	-
	169	211	8,3	4,5	2,1	162	-	238	2	0,37	1,8	2,7	1,8	-	-
	163	222	8,3	4,5	2,1	162	163	238	2	0,37	1,8	2,7	1,8	-	-
	178	234	13,9	7,5	3	164	-	256	2,5	0,26	2,6	3,9	2,5	-	-
	174	248	13,9	7,5	3	164	174	256	2,5	0,24	2,8	4,2	2,8	-	-
	175	228	11,1	6	3	164	-	256	2,5	0,35	1,9	2,9	1,8	-	-
	171	243	11,1	6	3	164	171	256	2,5	0,33	2	3	2	-	-
	188	266	16,7	9	4	167	-	303	3	0,35	1,9	2,9	1,8	-	-
	188	266	16,7	9	4	167	-	303	3	0,35	1,9	2,9	1,8	72 g	19 g
	188	266	16,7	9	4	167	-	303	3	0,35	1,9	2,9	1,8	72 g	19 g
181	281	16,7	9	4	167	181	303	3	0,33	2	3	2	-	-	
160	180	217	11,1	6	2,1	171	-	229	2	0,22	3	4,6	2,8	-	-
	177	225	11,1	6	2,1	171	177	229	2	0,2	3,4	5	3,2	-	-
	176	211	8,3	4,5	2,1	171	-	229	2	0,3	2,3	3,4	2,2	-	-
	173	218	8,3	4,5	2,1	171	173	229	2	0,28	2,4	3,6	2,5	-	-
	184	234	13,9	7,5	2,1	172	-	258	2	0,3	2,3	3,4	2,2	-	-
	180	244	13,9	7,5	2,1	172	180	258	2	0,28	2,4	3,6	2,5	-	-
	181	228	8,3	4,5	2,1	172	-	258	2	0,4	1,7	2,5	1,6	-	-
	176	239	8,3	4,5	2,1	172	176	258	2	0,37	1,8	2,7	1,8	-	-
	191	250	13,9	7,5	3	174	-	276	2,5	0,26	2,6	3,9	2,5	-	-
	185	264	13,9	7,5	3	174	185	276	2,5	0,25	2,7	4	2,5	-	-
	188	244	13,9	7,5	3	174	-	276	2,5	0,35	1,9	2,9	1,8	-	-
	200	282	16,7	9	4	177	-	323	3	0,35	1,9	2,9	1,8	-	-
	200	282	16,7	9	4	177	-	323	3	0,35	1,9	2,9	1,8	69 g	18 g
	200	282	16,7	9	4	177	-	323	3	0,35	1,9	2,9	1,8	69 g	18 g
	193	296	16,7	9	4	177	193	323	3	0,33	2	3	2	-	-

¹⁾ For details about permissible accelerations → [page 779](#)



9.1 Spherical roller bearings

d 170 – 180 mm

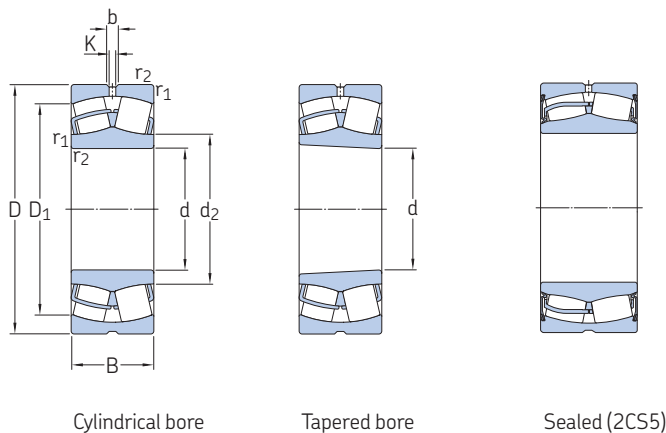

Cylindrical bore

Tapered bore

Sealed (2CS5)

Principal dimensions			Basic load ratings		Fatigue load limit P_u	Speed ratings		Mass	Designations	
d	D	B	dynamic C	static C_0		Reference speed	Limiting speed		Bearing with cylindrical bore	tapered bore
mm			kN		kN	r/min	kg	–		
170	260	67	745	1 060	100	2 200	2 800	13	▶ 23034 CC/W33	▶ 23034 CCK/W33
	260	67	746	1 080	100	–	630	13	▶ 23034-2CS5/VT143	▶ 23034-2CS5K/VT143
	260	90	963	1 460	137	1 600	2 400	17,5	▶ 24034 CC/W33	▶ 24034 CCK30/W33
	260	90	966	1 500	137	–	400	17,5	▶ 24034-2CS5/VT143	–
	280	88	1 086	1 500	137	1 800	2 400	22	▶ 23134 CC/W33	▶ 23134 CCK/W33
	280	88	1 088	1 500	137	–	480	22	▶ 23134-2CS5/VT143	▶ 23134-2CS5K/VT143
	280	109	1 270	1 860	170	1 200	1 800	27,5	▶ 24134 CC/W33	▶ 24134 CCK30/W33
	280	109	1 273	1 860	170	–	360	27,5	▶ 24134-2CS5/VT143	–
	310	86	1 183	1 460	132	1 900	2 600	28,5	▶ 22234 CC/W33	▶ 22234 CCK/W33
	310	86	1 185	1 460	134	–	500	28,5	▶ 22234-2CS5/VT143	▶ 22234-2CS5K/VT143
	310	110	1 472	1 930	173	1 400	2 000	37,5	▶ 23234 CC/W33	▶ 23234 CCK/W33
	360	120	1 863	2 160	176	1 400	1 800	61	▶ 22334 CC/W33	▶ 22334 CCK/W33
	360	120	1 863	2 160	176	1 400	1 800	61	▶ 22334 CCJA/W33VA405	22334 CCKJA/W33VA405
	360	120	1 863	2 160	176	1 400	1 800	61	22334 CCJA/W33VA406	–
180	250	52	519	830	76,5	2 600	2 800	7,9	▶ 23936 CC/W33	23936 CCK/W33
	280	74	883	1 250	114	2 000	2 600	17	▶ 23036 CC/W33	▶ 23036 CCK/W33
	280	74	884	1 270	114	–	560	17	▶ 23036-2CS5/VT143	▶ 23036-2CS5K/VT143
	280	100	1 134	1 730	156	1 500	2 200	23	▶ 24036 CC/W33	24036 CCK30/W33
	280	100	1 136	1 730	156	–	380	23	▶ 24036-2CS5/VT143	–
	300	96	1 263	1 760	160	1 700	2 200	28	▶ 23136 CC/W33	▶ 23136 CCK/W33
	300	96	1 264	1 800	160	–	430	28	▶ 23136-2CS5/VT143	▶ 23136-2CS5K/VT143
	300	118	1 449	2 160	196	1 100	1 600	34,5	▶ 24136 CC/W33	▶ 24136 CCK30/W33
	300	118	1 452	2 160	196	–	360	34,5	▶ 24136-2CS5/VT143	–
	320	86	1 237	1 560	140	1 800	2 600	29,5	▶ 22236 CC/W33	▶ 22236 CCK/W33
	320	86	1 239	1 560	140	–	530	29	▶ 22236-2CS5/VT143	▶ 22236-2CS5K/VT143
	320	112	1 557	2 120	186	1 300	1 900	39,5	▶ 23236 CC/W33	▶ 23236 CCK/W33
	380	126	2 077	2 450	193	1 300	1 700	71,5	▶ 22336 CC/W33	▶ 22336 CCK/W33
	380	126	2 077	2 450	193	1 300	1 700	71,5	▶ 22336 CCJA/W33VA405	22336 CCKJA/W33VA405
	380	126	2 077	2 450	193	1 300	1 700	71,5	22336 CCJA/W33VA406	–

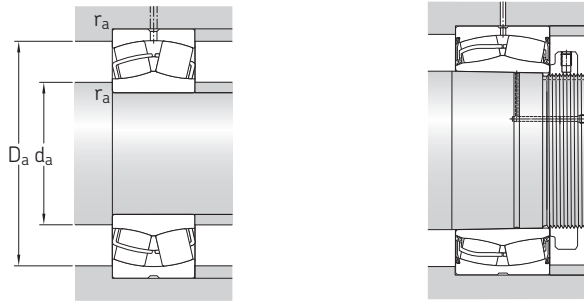

Dimensions					Abutment and fillet dimensions					Calculation factors				Permissible acceleration for oil lubrication ¹⁾	
d	d ₂ ≈	D ₁ ≈	b	K	r _{1,2} min.	d _a min.	d _a max.	D _a max.	r _a max.	e	Y ₁	Y ₂	Y ₀	rota- tional	linear
mm						mm				-				m/s ²	
170	191	232	11,1	6	2,1	181	-	249	2	0,23	2,9	4,4	2,8	-	-
	188	243	11,1	6	2,1	181	188	249	2	0,22	3	4,6	2,8	-	-
	188	226	8,3	4,5	2,1	181	-	249	2	0,33	2	3	2	-	-
	184	235	8,3	4,5	2,1	181	184	249	2	0,3	2,3	3,4	2,2	-	-
	195	244	13,9	7,5	2,1	182	-	268	2	0,3	2,3	3,4	2,2	-	-
	190	256	13,9	7,5	2,1	182	190	268	2	0,28	2,4	3,6	2,5	-	-
	190	237	8,3	4,5	2,1	182	-	268	2	0,37	1,8	2,7	1,8	-	-
	185	248	8,3	4,5	2,1	182	185	268	2	0,35	1,9	2,9	1,8	-	-
	203	267	16,7	9	4	187	-	293	3	0,27	2,5	3,7	2,5	-	-
	198	282	16,7	9	4	187	198	293	3	0,25	2,7	4	2,5	-	-
	200	261	13,9	7,5	4	187	-	293	3	0,35	1,9	2,9	1,8	-	-
	213	300	16,7	9	4	187	-	343	3	0,33	2	3	2	-	-
	213	300	16,7	9	4	187	-	343	3	0,33	2	3	2	65 g	18 g
	213	300	16,7	9	4	187	-	343	3	0,33	2	3	2	65 g	18 g
	180	199	231	6	3	2	189	-	241	2	0,18	3,8	5,6	3,6	-
204		249	13,9	7,5	2,1	191	-	269	2	0,24	2,8	4,2	2,8	-	-
199		262	13,9	7,5	2,1	191	199	269	2	0,22	3	4,6	2,8	-	-
201		243	8,3	4,5	2,1	191	-	269	2	0,33	2	3	2	-	-
194		251	8,3	4,5	2,1	191	194	269	2	0,31	2,2	3,3	2,2	-	-
207		259	13,9	7,5	3	194	-	286	2,5	0,3	2,3	3,4	2,2	-	-
202		272	13,9	7,5	3	194	202	286	2,5	0,28	2,4	3,6	2,5	-	-
203		253	11,1	6	3	194	-	286	2,5	0,37	1,8	2,7	1,8	-	-
198		266	11,1	6	3	194	198	286	2,5	0,37	1,8	2,7	1,8	-	-
213		278	16,7	9	4	197	-	303	3	0,26	2,6	3,9	2,5	-	-
208		289	16,7	9	4	197	208	303	3	0,24	2,8	4,2	2,8	-	-
211		271	13,9	7,5	4	197	-	303	3	0,35	1,9	2,9	1,8	-	-
224		317	22,3	12	4	197	-	363	3	0,35	1,9	2,9	1,8	-	-
224		317	22,3	12	4	197	-	363	3	0,35	1,9	2,9	1,8	59 g	17 g
224		317	22,3	12	4	197	-	363	3	0,35	1,9	2,9	1,8	59 g	17 g



¹⁾ For details about permissible accelerations → [page 779](#)

9.1 Spherical roller bearings

d 190 – 200 mm

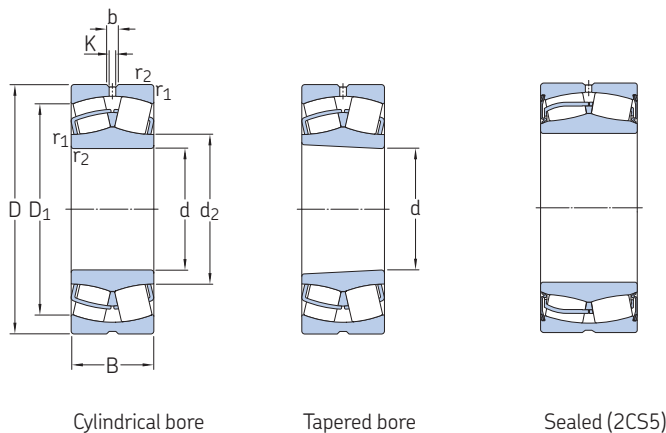

Principal dimensions			Basic load ratings		Fatigue load limit P_u	Speed ratings		Mass	Designations	
d	D	B	dynamic C	static C_0		Reference speed	Limiting speed		Bearing with cylindrical bore	tapered bore
mm			kN		kN	r/min	kg	–		
190	260	52	499	800	76,5	2 400	2 600	8,3	▶ 23938 CC/W33	23938 CCK/W33
	290	75	916	1 340	122	1 900	2 400	18	▶ 23038 CC/W33	▶ 23038 CCK/W33
	290	100	1 164	1 800	163	1 400	2 000	24,5	▶ 24038 CC/W33	▶ 24038 CCK30/W33
	320	104	1 456	2 080	183	1 500	2 000	35	▶ 23138 CC/W33	▶ 23138 CCK/W33
	320	104	1 458	2 080	183	–	400	35	▶ 23138-2CS5/VT143	▶ 23138-2CS5K/VT143
	320	128	1 652	2 500	212	1 100	1 500	43	▶ 24138 CC/W33	▶ 24138 CCK30/W33
	320	128	1 655	2 500	212	–	340	43	▶ 24138-2CS5/VT143	–
	340	92	1 342	1 700	150	1 700	2 400	36,5	▶ 22238 CC/W33	▶ 22238 CCK/W33
	340	92	1 345	1 700	150	–	480	35	▶ 22238-2CS5/VT143	▶ 22238-2CS5K/VT143
	340	120	1 759	2 400	208	1 300	1 800	48	▶ 23238 CC/W33	▶ 23238 CCK/W33
	400	132	2 232	2 650	208	1 200	1 600	82,5	▶ 22338 CC/W33	▶ 22338 CCK/W33
	400	132	2 232	2 650	208	1 200	1 600	82,5	▶ 22338 CCJA/W33VA405	▶ 22338 CCKJA/W33VA405
	400	132	2 232	2 650	208	1 200	1 600	82,5	22338 CCJA/W33VA406	–
	400	132	2 236	2 650	208	–	340	77,5	22338-2CS5/VT143	–
200	280	60	651	1 040	93	2 200	2 400	11,5	▶ 23940 CC/W33	23940 CCK/W33
	310	82	1 058	1 530	137	1 800	2 200	23,5	▶ 23040 CC/W33	▶ 23040 CCK/W33
	310	82	1 059	1 530	137	–	480	22	▶ 23040-2CS5/VT143	▶ 23040-2CS5K/VT143
	310	109	1 353	2 120	186	1 300	1 900	31	▶ 24040 CC/W33	▶ 24040 CCK30/W33
	340	112	1 665	2 360	204	1 500	1 900	43	▶ 23140 CC/W33	▶ 23140 CCK/W33
	340	112	1 668	2 360	204	–	380	43	▶ 23140-2CS5/VT143	▶ 23140-2CS5K/VT143
	340	140	1 865	2 800	232	1 000	1 400	53,5	▶ 24140 CC/W33	▶ 24140 CCK30/W33
	340	140	1 871	2 800	232	–	320	53,5	▶ 24140-2CS5/VT143	–
	360	98	1 526	1 930	166	1 600	2 200	43,5	▶ 22240 CC/W33	▶ 22240 CCK/W33
	360	98	1 529	1 930	166	–	430	42	▶ 22240-2CS5/VT143	▶ 22240-2CS5K/VT143
	360	128	1 947	2 700	228	1 200	1 700	58	▶ 23240 CC/W33	▶ 23240 CCK/W33
	360	128	1 950	2 700	232	–	340	58	▶ 23240-2CS5/VT143	▶ 23240-2CS5K/VT143
	420	138	2 439	2 900	224	1 200	1 500	95	▶ 22340 CC/W33	▶ 22340 CCK/W33
	420	138	2 439	2 900	224	1 200	1 500	95	▶ 22340 CCJA/W33VA405	▶ 22340 CCKJA/W33VA405
420	138	2 439	2 900	224	1 200	1 500	95	22340 CCJA/W33VA406	–	

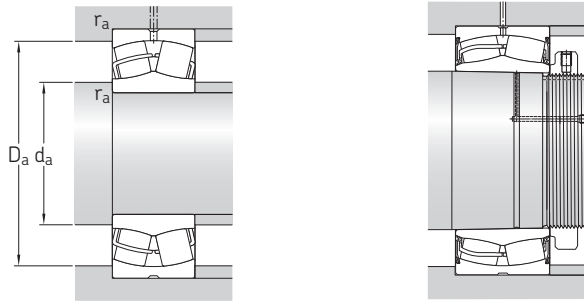

Dimensions			Abutment and fillet dimensions				Calculation factors				Permissible acceleration for oil lubrication ¹⁾				
d	d ₂	D ₁	b	K	r _{1,2} min.	d _a min.	d _a max.	D _a max.	r _a max.	e	Y ₁	Y ₂	Y ₀	rota- tional	linear
mm						mm				-				m/s ²	
190	209	240	6	3	2	199	-	251	2	0,16	4,2	6,3	4	-	-
	216	261	13,9	7,5	2,1	201	-	279	2	0,23	2,9	4,4	2,8	-	-
	210	253	8,3	4,5	2,1	201	-	279	2	0,31	2,2	3,3	2,2	-	-
	220	275	13,9	7,5	3	204	-	306	2,5	0,31	2,2	3,3	2,2	-	-
	215	288	13,9	7,5	3	204	215	306	2,5	0,3	2,3	3,4	2,2	-	-
	215	268	11,1	6	3	204	-	306	2,5	0,4	1,7	2,5	1,6	-	-
	210	282	11,1	6	3	204	210	306	2,5	0,37	1,8	2,7	1,8	-	-
	225	294	16,7	9	4	207	-	323	3	0,26	2,6	3,9	2,5	-	-
	220	306	16,7	9	4	207	220	323	3	0,24	2,8	4,2	2,8	-	-
	222	287	16,7	9	4	207	-	323	3	0,35	1,9	2,9	1,8	-	-
	236	333	22,3	12	5	210	-	380	4	0,35	1,9	2,9	1,8	-	-
	236	333	22,3	12	5	210	-	380	4	0,35	1,9	2,9	1,8	57 g	17 g
236	333	22,3	12	5	210	-	380	4	0,35	1,9	2,9	1,8	57 g	17 g	
228	352	22,3	12	5	210	228	380	4	0,33	2	3	2	-	-	
200	222	258	8,3	4,5	2,1	211	-	269	2	0,19	3,6	5,3	3,6	-	-
	228	278	13,9	7,5	2,1	211	-	299	2	0,24	2,8	4,2	2,8	-	-
	223	286	13,9	7,5	2,1	211	223	299	2	0,22	3	4,6	2,8	-	-
	223	268	11,1	6	2,1	211	-	299	2	0,33	2	3	2	-	-
	231	293	16,7	9	3	214	-	326	2,5	0,31	2,2	3,3	2,2	-	-
	227	306	16,7	9	3	214	227	326	2,5	0,3	2,3	3,4	2,2	-	-
	226	284	11,1	6	3	214	-	326	2,5	0,4	1,7	2,5	1,6	-	-
	221	294	11,1	6	3	214	221	326	2,5	0,37	1,8	2,7	1,8	-	-
	238	313	16,7	9	4	217	-	343	3	0,26	2,6	3,9	2,5	-	-
	232	324	16,7	9	4	217	232	343	3	0,24	2,8	4,2	2,8	-	-
	235	304	16,7	9	4	217	-	343	3	0,35	1,9	2,9	1,8	-	-
	230	320	16,7	9	4	217	230	343	3	0,33	2	3	2	-	-
249	351	22,3	12	5	220	-	400	4	0,33	2	3	2	-	-	
249	351	22,3	12	5	220	-	400	4	0,33	2	3	2	55 g	17 g	
249	351	22,3	12	5	220	-	400	4	0,33	2	3	2	55 g	17 g	



¹⁾ For details about permissible accelerations → [page 779](#)

9.1 Spherical roller bearings

d 220 – 260 mm

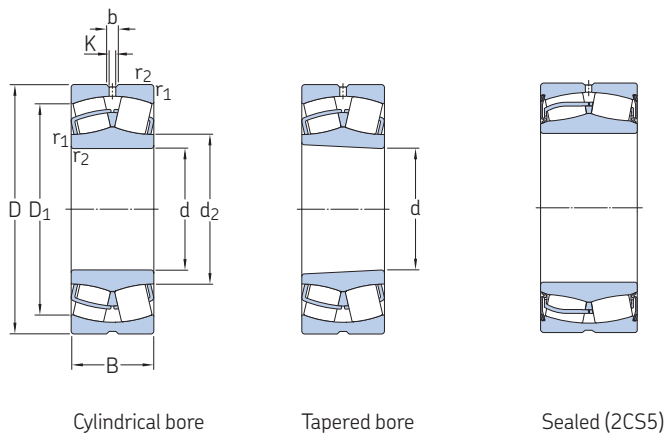

Cylindrical bore

Tapered bore

Sealed (2CS5)

Principal dimensions			Basic load ratings		Fatigue load limit P_u	Speed ratings		Mass	Designations		
d	D	B	dynamic C	static C_0		Reference speed	Limiting speed		Bearing with cylindrical bore	tapered bore	
mm			kN		kN	r/min	kg	–			
220	300	60	661	1 080	93	2 000	2 200	12,5	▶ 23944 CC/W33	23944 CCK/W33	
	300	60	662	1 080	93	–	600	12,5	▶ 23944-2CS/VT143	–	
	340	90	1 261	1 860	163	1 600	2 000	30,5	▶ 23044 CC/W33	▶ 23044 CCK/W33	
	340	90	1 262	1 860	163	–	430	29	▶ 23044-2CS5/VT143	▶ 23044-2CS5K/VT143	
	340	118	1 628	2 600	212	1 200	1 700	40	▶ 24044 CC/W33	▶ 24044 CCK30/W33	
	370	120	1 888	2 750	232	1 300	1 700	53,5	▶ 23144 CC/W33	▶ 23144 CCK/W33	
	370	120	1 891	2 750	232	–	360	53,5	▶ 23144-2CS5/VT143	▶ 23144-2CS5K/VT143	
	370	150	2 197	3 350	285	850	1 200	67	▶ 24144 CC/W33	▶ 24144 CCK30/W33	
	400	108	1 835	2 360	196	1 500	2 000	60,5	▶ 22244 CC/W33	▶ 22244 CCK/W33	
	400	108	1 839	2 360	200	–	380	58	▶ 22244-2CS5/VT143	▶ 22244-2CS5K/VT143	
	400	144	2 485	3 450	285	1 100	1 500	81,5	▶ 23244 CC/W33	▶ 23244 CCK/W33	
	460	145	2 839	3 450	260	1 000	1 400	120	▶ 22344 CC/W33	▶ 22344 CCK/W33	
	460	145	2 839	3 450	260	1 000	1 400	120	▶ 22344 CCJA/W33VA405	22344 CCKJA/W33VA405	
	460	145	2 844	3 450	260	–	300	115	▶ 22344-2CS5/VT143	▶ 22344-2CS5K/VT143	
240	320	60	685	1 160	98	1 900	2 000	13,5	▶ 23948 CC/W33	23948 CCK/W33	
	360	92	1 340	2 080	176	1 500	1 900	33,5	▶ 23048 CC/W33	▶ 23048 CCK/W33	
	360	92	1 341	2 080	176	–	400	32	▶ 23048-2CS5/VT143	23048-2CS5K/VT143	
	360	118	1 663	2 700	228	1 100	1 600	43	▶ 24048 CC/W33	24048 CCK30/W33	
	400	128	2 187	3 200	255	1 200	1 600	66,5	▶ 23148 CC/W33	▶ 23148 CCK/W33	
	400	128	2 191	3 200	255	–	340	66,5	▶ 23148-2CS5/VT143	▶ 23148-2CS5K/VT143	
	400	160	2 489	3 900	320	750	1 100	83	▶ 24148 CC/W33	▶ 24148 CCK30/W33	
	440	120	2 258	3 000	245	1 300	1 800	83	▶ 22248 CC/W33	▶ 22248 CCK/W33	
	440	160	3 042	4 300	345	950	1 300	110	▶ 23248 CC/W33	▶ 23248 CCK/W33	
	500	155	3 229	4 000	290	950	1 300	155	▶ 22348 CC/W33	▶ 22348 CCK/W33	
	500	155	3 229	4 000	290	950	1 300	155	22348 CCJA/W33VA405	22348 CCKJA/W33VA405	
	260	360	75	1 055	1 800	156	1 700	1 900	23,5	▶ 23952 CC/W33	23952 CCK/W33
		400	104	1 675	2 550	212	1 300	1 700	48,5	▶ 23052 CC/W33	▶ 23052 CCK/W33
		400	104	1 677	2 550	212	–	360	46	▶ 23052-2CS5/VT143	▶ 23052-2CS5K/VT143
400		140	2 135	3 450	285	1 000	1 400	65,5	▶ 24052 CC/W33	▶ 24052 CCK30/W33	
440		144	2 664	3 900	290	1 100	1 400	90,5	▶ 23152 CC/W33	▶ 23152 CCK/W33	
440		144	2 668	3 900	290	–	320	90,5	▶ 23152-2CS5/VT143	▶ 23152-2CS5K/VT143	
440		180	3 086	4 800	380	670	950	110	▶ 24152 CC/W33	▶ 24152 CCK30/W33	
440		180	3 092	4 900	380	–	240	109	24152-2CS5/VT143	–	
480		130	2 722	3 550	285	1 200	1 600	110	▶ 22252 CC/W33	22252 CCK/W33	
480		174	3 395	4 750	360	850	1 200	140	▶ 23252 CC/W33	▶ 23252 CCK/W33	
540		165	3 680	4 550	325	850	1 100	190	▶ 22352 CC/W33	▶ 22352 CCK/W33	

SKF Explorer bearing

▶ Popular item

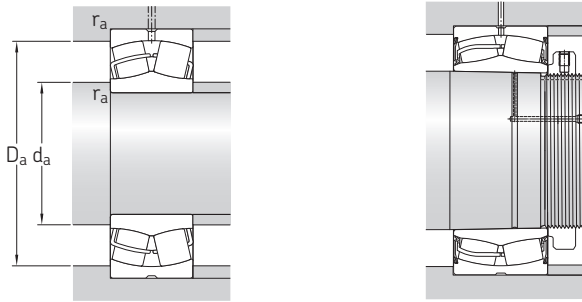

Dimensions					Abutment and fillet dimensions					Calculation factors				Permissible acceleration for oil lubrication ¹⁾	
d	d ₂ ≈	D ₁ ≈	b	K	r _{1,2} min.	d _a min.	d _a max.	D _a max.	r _a max.	e	Y ₁	Y ₂	Y ₀	rota- tional	linear
mm						mm				-				m/s ²	
220	241	278	8,3	4,5	2,1	231	-	289	2	0,16	4,2	6,3	4	-	-
	238	284	8,3	4,5	2,1	231	238	289	2	0,15	4,5	6,7	4,5	-	-
	250	306	13,9	7,5	3	233	-	327	2,5	0,24	2,8	4,2	2,8	-	-
	245	314	13,9	7,5	3	233	245	327	2,5	0,22	3	4,6	2,8	-	-
	244	295	11,1	6	3	233	-	327	2,5	0,33	2	3	2	-	-
	255	320	16,7	9	4	237	-	353	3	0,3	2,3	3,4	2,2	-	-
	249	332	16,7	9	4	237	249	353	3	0,28	2,4	3,6	2,5	-	-
	248	310	11,1	6	4	237	-	353	3	0,4	1,7	2,5	1,6	-	-
	263	346	16,7	9	4	237	-	383	3	0,27	2,5	3,7	2,5	-	-
	257	359	16,7	9	4	237	257	383	3	0,25	2,7	4	2,5	-	-
	259	338	16,7	9	4	237	-	383	3	0,35	1,9	2,9	1,8	-	-
	279	389	22,3	12	5	240	-	440	4	0,31	2,2	3,3	2,2	-	-
279	389	22,3	12	5	240	-	440	4	0,31	2,2	3,3	2,2	49 g	16 g	
270	406	22,3	12	5	240	270	440	4	0,3	2,3	3,4	2,2	-	-	
240	261	298	8,3	4,5	2,1	251	-	309	2	0,15	4,5	6,7	4,5	-	-
	271	326	13,9	7,5	3	253	-	347	2,5	0,23	2,9	4,4	2,8	-	-
	265	333	13,9	7,5	3	253	265	347	2,5	0,21	3,2	4,8	3,2	-	-
	265	316	11,1	6	3	253	-	347	2,5	0,3	2,3	3,4	2,2	-	-
	277	348	16,7	9	4	257	-	383	3	0,3	2,3	3,4	2,2	-	-
	270	360	16,7	9	4	257	270	383	3	0,28	2,4	3,6	2,5	-	-
	271	336	11,1	6	4	257	-	383	3	0,4	1,7	2,5	1,6	-	-
	290	383	22,3	12	4	257	-	423	3	0,27	2,5	3,7	2,5	-	-
	286	374	22,3	12	4	257	-	423	3	0,35	1,9	2,9	1,8	-	-
	303	423	22,3	12	5	260	-	480	4	0,31	2,2	3,3	2,2	-	-
	303	423	22,3	12	5	260	-	480	4	0,31	2,2	3,3	2,2	45 g	15 g
	260	287	331	8,3	4,5	2,1	271	-	349	2	0,18	3,8	5,6	3,6	-
295		360	16,7	9	4	275	-	385	3	0,23	2,9	4,4	2,8	-	-
289		369	16,7	9	4	275	289	385	3	0,22	3	4,6	2,8	-	-
289		347	11,1	6	4	275	-	385	3	0,33	2	3	2	-	-
301		380	16,7	9	4	277	-	423	3	0,31	2,2	3,3	2,2	-	-
293		398	16,7	9	4	277	293	423	3	0,3	2,3	3,4	2,2	-	-
293		368	13,9	7,5	4	277	-	423	3	0,4	1,7	2,5	1,6	-	-
286		391	13,9	7,5	4	277	286	423	3	0,4	1,7	2,5	1,6	-	-
312		421	22,3	12	5	280	-	460	4	0,27	2,5	3,7	2,5	-	-
312		408	22,3	12	5	280	-	460	4	0,35	1,9	2,9	1,8	-	-
328		458	22,3	12	6	286	-	514	5	0,31	2,2	3,3	2,2	-	-

¹⁾ For details about permissible accelerations → [page 779](#)



9.1 Spherical roller bearings

d 280 – 320 mm

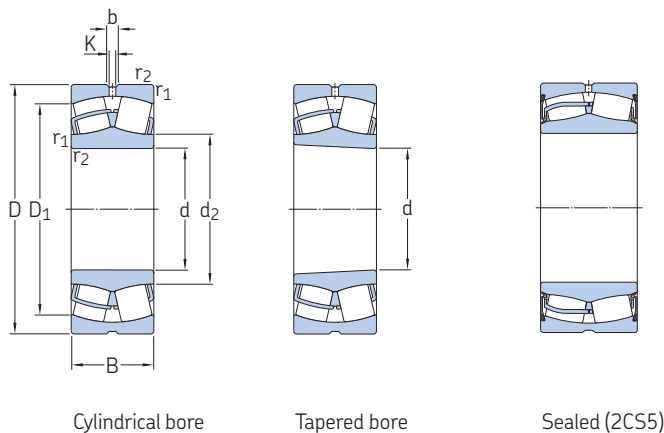

Cylindrical bore

Tapered bore

Sealed (2CS5)

Principal dimensions			Basic load ratings		Fatigue load limit P_u	Speed ratings		Mass	Designations	
d	D	B	dynamic C	static C_0		Reference speed	Limiting speed		Bearing with cylindrical bore	tapered bore
mm			kN		kN	r/min	kg	–		
280	380	75	1 016	1 760	143	1 600	1 700	25	▶ 23956 CC/W33	23956 CCK/W33
	420	106	1 797	2 850	224	1 300	1 600	52,5	▶ 23056 CC/W33	▶ 23056 CCK/W33
	420	140	2 248	3 800	285	950	1 400	69,5	▶ 24056 CC/W33	▶ 24056 CCK30/W33
	460	146	2 784	4 250	335	1 000	1 300	97	▶ 23156 CC/W33	▶ 23156 CCK/W33
	460	146	2 788	4 250	335	–	300	97	▶ 23156-2CS5/VT143	▶ 23156-2CS5K/VT143
	460	180	3 183	5 100	415	630	900	120	▶ 24156 CC/W33	▶ 24156 CCK30/W33
	460	180	3 190	5 100	415	–	220	115	24156-2CS5/VT143	24156-2CS5K30/VT143
	500	130	2 795	3 750	300	1 100	1 500	115	▶ 22256 CC/W33	22256 CCK/W33
	500	176	3 425	4 900	365	800	1 100	150	▶ 23256 CC/W33	▶ 23256 CCK/W33
	580	175	4 158	5 200	365	800	1 100	235	▶ 22356 CC/W33	▶ 22356 CCK/W33
300	420	90	1 413	2 500	200	1 400	1 600	39,5	▶ 23960 CC/W33	23960 CCK/W33
	460	118	2 219	3 450	265	1 200	1 500	71,5	▶ 23060 CC/W33	▶ 23060 CCK/W33
	460	118	2 222	3 450	265	–	320	71,5	23060-2CS5/VT143	23060-2CS5K/VT143
	460	160	2 821	4 750	355	850	1 200	97	▶ 24060 CC/W33	▶ 24060 CCK30/W33
	460	160	2 827	4 750	355	–	240	95	24060-2CS5/VT143	–
	500	160	3 368	5 100	380	950	1 200	125	▶ 23160 CC/W33	▶ 23160 CCK/W33
	500	160	3 373	5 100	380	–	260	125	▶ 23160-2CS5/VT143	▶ 23160-2CS5K/VT143
	500	200	3 876	6 300	465	560	800	160	▶ 24160 CC/W33	▶ 24160 CCK30/W33
	500	200	3 881	6 300	465	–	212	156	24160-2CS5/VT143	24160-2CS5K30/VT143
	540	140	3 239	4 250	325	1 000	1 400	135	▶ 22260 CC/W33	22260 CCK/W33
540	192	4 052	5 850	425	750	1 000	190	▶ 23260 CC/W33	▶ 23260 CCK/W33	
320	440	90	1 480	2 700	212	1 400	1 500	42	▶ 23964 CC/W33	23964 CCK/W33
	480	121	2 348	3 800	285	–	320	7,55	23064-2CS5/VT143	23064-2CS5K/VT143
	480	121	2 348	3 800	285	1 100	1 400	78	▶ 23064 CC/W33	▶ 23064 CCK/W33
	480	160	2 969	5 100	400	800	1 200	100	▶ 24064 CC/W33	24064 CCK30/W33
	540	176	3 923	6 000	440	850	1 100	165	▶ 23164 CC/W33	▶ 23164 CCK/W33
	540	176	3 929	6 100	440	–	260	165	▶ 23164-2CS5/VT143	▶ 23164-2CS5K/VT143
	540	218	4 395	7 100	510	500	700	210	▶ 24164 CC/W33	24164 CCK30/W33
	580	150	3 708	4 900	375	950	1 300	175	▶ 22264 CC/W33	22264 CCK/W33
	580	208	4 607	6 700	475	700	950	240	▶ 23264 CC/W33	▶ 23264 CCK/W33

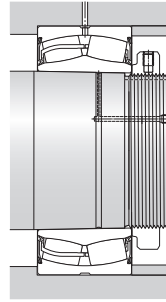
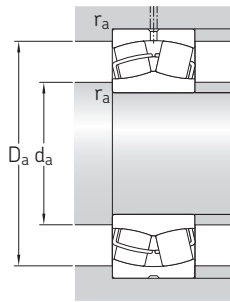

Dimensions						Abutment and fillet dimensions				Calculation factors				Permissible acceleration for oil lubrication ¹⁾		
d	d ₂	D ₁	b	K	r _{1,2}	d _a min.	d _a max.	D _a max.	r _a max.	e	Y ₁	Y ₂	Y ₀	rotational	linear	
mm						mm				-				m/s ²		
280	308	352	11,1	6	2,1	291	-	369	2	0,16	4,2	6,3	4	-	-	
	315	380	16,7	9	4	295	-	405	3	0,23	2,9	4,4	2,8	-	-	
	309	368	11,1	6	4	295	-	405	3	0,31	2,2	3,3	2,2	-	-	
	321	401	16,7	9	5	300	-	440	4	0,3	2,3	3,4	2,2	-	-	
	314	417	16,7	9	5	300	314	440	4	0,28	2,4	3,6	2,5	-	-	
	314	390	13,9	7,5	5	300	-	440	4	0,4	1,7	2,5	1,6	-	-	
	307	413	13,9	7,5	5	300	307	440	4	0,37	1,8	2,7	1,8	-	-	
	333	441	22,3	12	5	300	-	480	4	0,26	2,6	3,9	2,5	-	-	
	332	429	22,3	12	5	300	-	480	4	0,35	1,9	2,9	1,8	-	-	
	354	492	22,3	12	6	306	-	554	5	0,3	2,3	3,4	2,2	-	-	
	300	333	385	11,1	6	3	313	-	407	2,5	0,19	3,6	5,3	3,6	-	-
		340	414	16,7	9	4	315	-	445	3	0,23	2,9	4,4	2,8	-	-
334		433	16,7	9	4	315	334	445	3	0,22	3	4,6	2,8	-	-	
331		400	13,9	7,5	4	315	-	445	3	0,33	2	3	2	-	-	
325		416	13,9	7,5	4	315	325	445	3	0,31	2,2	3,3	2,2	-	-	
345		434	16,7	9	5	320	-	480	4	0,3	2,3	3,4	2,2	-	-	
337		451	16,7	9	5	320	337	480	4	0,28	2,4	3,6	2,5	-	-	
338		422	13,9	7,5	5	320	-	480	4	0,4	1,7	2,5	1,6	-	-	
330		447	13,9	7,5	5	320	330	480	4	0,37	1,8	2,7	1,8	-	-	
354		477	22,3	12	5	311	-	520	4	0,26	2,6	3,9	2,5	-	-	
356		461	22,3	12	5	320	-	520	4	0,35	1,9	2,9	1,8	-	-	
320		354	406	11,1	6	3	333	-	427	2,5	0,17	4	5,9	4	-	-
	354	448	16,7	9	4	335	354	465	3	0,23	2,9	4,4	2,8	-	-	
	360	434	16,7	9	4	335	-	465	3	0,23	2,9	4,4	2,8	-	-	
	354	423	13,9	7,5	4	335	-	465	3	0,31	2,2	3,3	2,2	-	-	
	370	465	22,3	12	5	340	-	520	4	0,31	2,2	3,3	2,2	-	-	
	361	483	22,3	12	5	340	361	520	4	0,3	2,3	3,4	2,2	-	-	
	364	455	16,7	9	5	340	-	520	4	0,4	1,7	2,5	1,6	-	-	
	379	513	22,3	12	5	340	-	560	4	0,26	2,6	3,9	2,5	-	-	
	382	493	22,3	12	5	340	-	560	4	0,35	1,9	2,9	1,8	-	-	

¹⁾ For details about permissible accelerations → page 779



9.1 Spherical roller bearings

d 340 – 400 mm

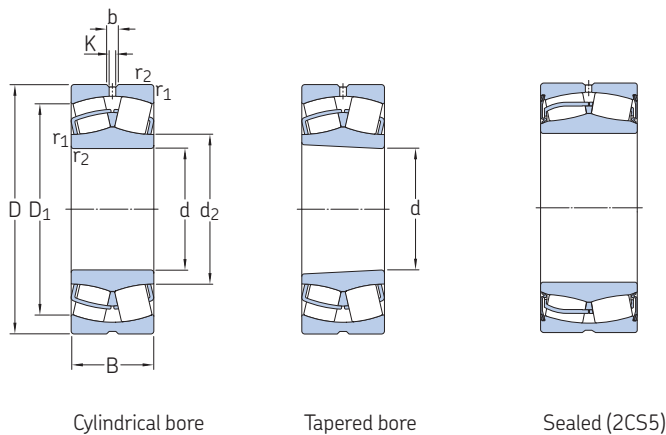

Principal dimensions			Basic load ratings		Fatigue load limit P_u	Speed ratings		Mass	Designations	
d	D	B	dynamic C	static C_0		Reference speed	Limiting speed		Bearing with cylindrical bore	tapered bore
mm			kN		kN	r/min	kg	–		
340	460	90	1 490	2 800	216	1 300	1 400	45,5	▶ 23968 CC/W33	▶ 23968 CCK/W33
	520	133	2 812	4 550	335	1 000	1 300	105	▶ 23068 CC/W33	▶ 23068 CCK/W33
	520	180	3 621	6 200	475	750	1 100	140	▶ 24068 CC/W33	▶ 24068 CCK30/W33
	580	190	4 445	6 800	480	800	1 000	210	▶ 23168 CC/W33	▶ 23168 CCK/W33
	580	190	4 452	6 800	490	–	240	210	▶ 23168-2CS5/VT143	▶ 23168-2CS5K/VT143
	580	243	5 487	8 650	630	430	630	280	▶ 24168 ECCJ/W33	▶ 24168 ECCK30J/W33
	620	224	5 362	7 800	550	560	800	295	▶ 23268 CA/W33	▶ 23268 CAK/W33
360	480	90	1 456	2 750	220	1 200	1 300	46	▶ 23972 CC/W33	▶ 23972 CCK/W33
	540	134	2 850	4 800	345	950	1 200	110	▶ 23072 CC/W33	▶ 23072 CCK/W33
	540	180	3 705	6 550	490	700	1 000	145	▶ 24072 CC/W33	▶ 24072 CCK30/W33
	600	192	4 515	6 950	490	750	1 000	220	▶ 23172 CC/W33	▶ 23172 CCK/W33
	600	192	4 521	6 950	490	–	220	214	▶ 23172-2CS5/VT143	▶ 23172-2CS5K/VT143
	600	243	5 737	9 300	670	400	600	280	▶ 24172 ECCJ/W33	▶ 24172 ECCK30J/W33
	650	170	4 430	6 200	440	630	850	255	▶ 22272 CA/W33	▶ 22272 CAK/W33
380	520	106	2 011	3 800	285	1 100	1 200	69	▶ 23976 CC/W33	▶ 23976 CCK/W33
	560	135	2 984	5 000	360	900	1 200	115	▶ 23076 CC/W33	▶ 23076 CCK/W33
	560	180	3 786	6 800	475	670	950	150	▶ 24076 CC/W33	▶ 24076 CCK30/W33
	620	194	4 561	7 100	500	–	160	232	▶ 23176-2CS5/VT143	▶ 23176-2CS5K/VT143
	620	194	4 561	7 100	500	560	1 000	230	▶ 23176 CA/W33	▶ 23176 CAK/W33
	620	243	5 936	9 800	710	360	530	300	▶ 24176 ECA/W33	▶ 24176 ECAK30/W33
	680	240	6 126	9 150	620	500	750	375	▶ 23276 CA/W33	▶ 23276 CAK/W33
400	540	106	2 038	3 900	290	1 100	1 200	71	▶ 23980 CC/W33	▶ 23980 CCK/W33
	600	148	3 511	5 850	415	850	1 100	150	▶ 23080 CC/W33	▶ 23080 CCK/W33
	600	148	3 515	5 850	415	–	240	144	▶ 23080-2CS5/VT143	▶ 23080-2CS5K/VT143
	600	200	4 507	8 000	560	630	900	205	▶ 24080 ECCJ/W33	▶ 24080 ECCK30J/W33
	650	200	4 864	7 650	530	–	150	255	▶ 23180-2CS5/VT143	▶ 23180-2CS5K/VT143
	650	200	4 864	7 650	530	530	950	265	▶ 23180 CA/W33	▶ 23180 CAK/W33
	650	250	6 331	10 600	735	340	500	340	▶ 24180 ECA/W33	▶ 24180 ECAK30/W33
720	256	6 881	10 400	680	480	670	450	▶ 23280 CA/W33	▶ 23280 CAK/W33	
820	243	7 832	10 400	670	430	750	650	▶ 22380 CA/W33	▶ 22380 CAK/W33	

SKF Explorer bearing

▶ Popular item

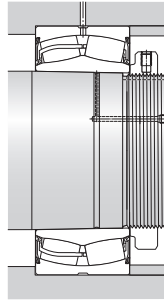
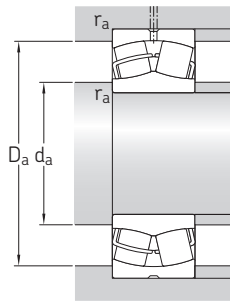

Dimensions						Abutment and fillet dimensions				Calculation factors				Permissible acceleration for oil lubrication ¹⁾		
d	d ₂ ≈	D ₁ ≈	b	K	r _{1,2} min.	d _a min.	d _a max.	D _a max.	r _a max.	e	Y ₁	Y ₂	Y ₀	rota- tional	linear	
mm						mm				-				m/s ²		
340	373	426	11,1	6	3	353	-	447	2,5	0,17	4	5,9	4	-	-	
	385	468	22,3	12	5	358	-	502	4	0,24	2,8	4,2	2,8	-	-	
	377	453	16,7	9	5	358	-	502	4	0,33	2	3	2	-	-	
	394	498	22,3	12	5	360	-	560	4	0,31	2,2	3,3	2,2	-	-	
	385	515	22,3	12	5	360	385	560	4	0,3	2,3	3,4	2,2	-	-	
	383	491	16,7	9	5	360	-	560	4	0,4	1,7	2,5	1,6	-	-	
	427	528	22,3	12	6	366	-	594	5	0,35	1,9	2,9	1,8	-	-	
	360	394	447	11,1	6	3	373	-	467	2,5	0,15	4,5	6,7	4,5	-	-
		404	483	22,3	12	5	378	-	522	4	0,23	2,9	4,4	2,8	-	-
397		474	16,7	9	5	378	-	522	4	0,31	2,2	3,3	2,2	-	-	
418		524	22,3	12	5	380	-	580	4	0,3	2,3	3,4	2,2	-	-	
408		541	22,3	12	5	380	408	580	4	0,28	2,4	3,6	2,5	-	-	
404		511	16,7	9	5	380	-	580	4	0,4	1,7	2,5	1,6	-	-	
454		568	22,3	12	6	386	-	624	5	0,26	2,6	3,9	2,5	-	-	
449		552	22,3	12	6	386	-	624	5	0,35	1,9	2,9	1,8	-	-	
429		581	22,3	12	6	386	429	624	5	0,35	1,9	2,9	1,8	-	-	
380	419	481	13,9	7,5	4	395	-	505	3	0,17	4	5,9	4	-	-	
	426	509	22,3	12	5	398	-	542	4	0,22	3	4,6	2,8	-	-	
	419	497	16,7	9	5	398	-	542	4	0,3	2,3	3,4	2,2	-	-	
	438	573	22,3	12	5	400	438	600	4	0,3	2,3	3,4	2,2	-	-	
	454	541	22,3	12	5	400	-	600	4	0,3	2,3	3,4	2,2	-	-	
	444	532	16,7	9	5	400	-	600	4	0,37	1,8	2,7	1,8	-	-	
	473	581	22,3	12	6	406	-	654	5	0,35	1,9	2,9	1,8	-	-	
	400	439	500	13,9	7,5	4	415	-	525	3	0,16	4,2	6,3	4	-	-
		450	543	22,3	12	5	418	-	582	4	0,23	2,9	4,4	2,8	-	-
443		557	22,3	12	5	418	443	582	4	0,21	3,2	4,8	3,2	-	-	
442		527	22,3	12	5	418	-	582	4	0,3	2,3	3,4	2,2	-	-	
458		587	22,3	12	6	426	458	624	5	0,28	2,4	3,6	2,5	-	-	
475		566	22,3	12	6	426	-	624	5	0,28	2,4	3,6	2,5	-	-	
467		559	22,3	12	6	426	-	624	5	0,37	1,8	2,7	1,8	-	-	
500		615	22,3	12	6	426	-	694	5	0,35	1,9	2,9	1,8	-	-	
534		697	22,3	12	7,5	432	-	788	6	0,3	2,3	3,4	2,2	-	-	

¹⁾ For details about permissible accelerations → [page 779](#)



9.1 Spherical roller bearings

d 420 – 480 mm

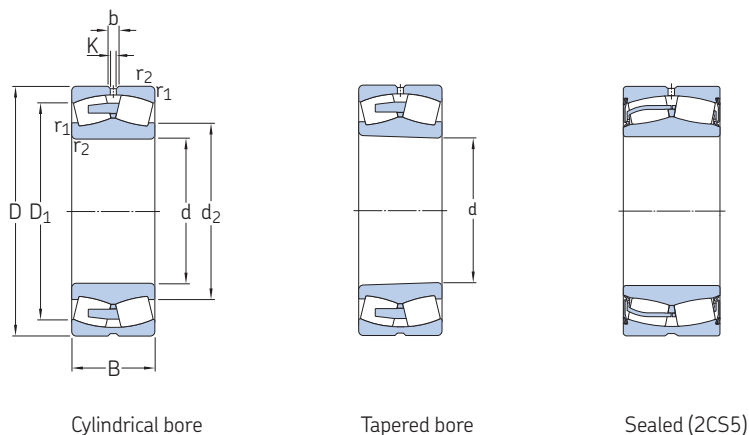

Cylindrical bore

Tapered bore

Sealed (2CS5)

Principal dimensions			Basic load ratings		Fatigue load limit P_u	Speed ratings		Mass	Designations		
d	D	B	dynamic C	static C_0		Reference speed	Limiting speed		Bearing with cylindrical bore	tapered bore	
mm			kN		kN	r/min	kg	–			
420	560	106	2 083	4 150	300	1 000	1 100	74,5	▶ 23984 CC/W33	23984 CCK/W33	
	620	150	3 541	6 000	415	600	1 100	155	▶ 23084 CA/W33	23084 CAK/W33	
	620	200	4 610	8 300	585	530	900	210	▶ 24084 ECA/W33	24084 ECAK30/W33	
	700	224	5 919	9 300	620	–	190	350	23184-2CS5/VT143	23184-2CS5K/VT143	
	700	224	5 919	9 300	620	480	900	350	▶ 23184 CJ/W33	▶ 23184 CKJ/W33	
	700	280	7 577	12 500	850	320	480	445	▶ 24184 ECA/W33	24184 ECAK30/W33	
	760	272	7 677	11 600	765	450	630	535	23284 CA/W33	23284 CAK/W33	
	760	272	7 683	11 600	765	–	128	535	23284-2CS5/VT143	23284-2CS5K/VT143	
	440	600	118	2 506	4 900	345	950	1 000	99,5	▶ 23988 CC/W33	23988 CCK/W33
		650	157	3 831	6 550	450	560	1 000	180	▶ 23088 CA/W33	▶ 23088 CAK/W33
650		157	3 834	6 550	450	–	190	178	23088-2CS5/VT143	–	
650		212	4 987	9 150	630	500	850	245	▶ 24088 ECA/W33	24088 ECAK30/W33	
720		226	6 215	10 000	670	450	850	360	▶ 23188 CA/W33	▶ 23188 CAK/W33	
720		226	6 220	10 000	670	–	180	360	23188-2CS5/VT143	23188-2CS5K/VT143	
720		280	7 777	13 200	900	300	450	460	24188 ECA/W33	24188 ECAK30/W33	
790		280	8 150	12 500	800	430	600	590	23288 CA/W33	23288 CAK/W33	
460		580	118	2 082	4 900	345	630	1 100	75,5	24892 CAMA/W20	24892 CAK30MA/W20
		620	118	2 558	5 000	355	600	1 000	105	▶ 23992 CA/W33	23992 CAK/W33
	680	163	4 065	6 950	465	560	950	205	▶ 23092 CA/W33	23092 CAK/W33	
	680	218	5 401	10 000	670	480	800	275	▶ 24092 ECA/W33	24092 ECAK30/W33	
	760	240	6 760	10 800	680	430	800	440	▶ 23192 CA/W33	23192 CAK/W33	
	760	240	6 765	10 800	680	–	128	427	▶ 23192-2CS5/VT143	23192-2CS5K/VT143	
	760	300	8 608	14 600	1 000	280	430	560	24192 ECA/W33	24192 ECAK30/W33	
	830	296	8 958	13 700	880	400	560	695	23292 CA/W33	23292 CAK/W33	
	480	650	128	2 990	5 700	405	560	1 000	125	▶ 23996 CA/W33	23996 CAK/W33
		700	165	3 996	6 800	450	530	950	215	▶ 23096 CA/W33	23096 CAK/W33
700		218	5 524	10 400	695	450	750	285	▶ 24096 ECA/W33	24096 ECAK30/W33	
790		248	7 362	12 000	780	400	750	485	23196 CA/W33	23196 CAK/W33	
790		248	7 367	12 000	780	–	170	485	23196-2CS5/VT143	23196-2CS5K/VT143	
790		308	9 198	15 600	1 040	260	400	605	24196 ECA/W33	24196 ECAK30/W33	
870		310	9 805	15 000	950	380	530	800	23296 CA/W33	23296 CAK/W33	

SKF Explorer bearing

▶ Popular item

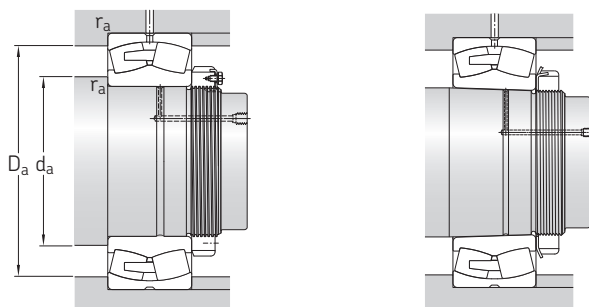

Dimensions					Abutment and fillet dimensions					Calculation factors				Permissible acceleration for oil lubrication ¹⁾	
d	d ₂ ≈	D ₁ ≈	b	K	r _{1,2} min.	d _a min.	d _a max.	D _a max.	r _a max.	e	Y ₁	Y ₂	Y ₀	rota- tional	linear
mm						mm				-				m/s ²	
420	459	520	16,7	9	4	435	-	545	3	0,16	4,2	6,3	4	-	-
	487	563	22,3	12	5	438	-	602	4	0,22	3	4,6	2,8	-	-
	477	547	22,3	12	5	438	-	602	4	0,3	2,3	3,4	2,2	-	-
	490	634	22,3	12	6	446	490	674	5	0,3	2,3	3,4	2,2	-	-
	483	607	22,3	12	6	446	-	674	5	0,3	2,3	3,4	2,2	-	-
	494	597	22,3	12	6	446	-	674	5	0,4	1,7	2,5	1,6	-	-
	526	649	22,3	12	7,5	452	-	728	6	0,35	1,9	2,9	1,8	-	-
	500	676	22,3	12	7,5	452	500	728	6	0,35	1,9	2,9	1,8	-	-
440	484	553	16,7	9	4	455	-	585	3	0,16	4,2	6,3	4	-	-
	511	590	22,3	12	6	463	-	627	5	0,22	3	4,6	2,8	-	-
	505	614	22,3	12	6	463	505	627	5	0,21	3,2	4,8	3,2	-	-
	499	572	22,3	12	6	463	-	627	5	0,3	2,3	3,4	2,2	-	-
	529	632	22,3	12	6	466	-	694	5	0,3	2,3	3,4	2,2	-	-
	513	664	22,3	12	6	466	513	694	5	0,28	2,4	3,6	2,5	-	-
	516	618	22,3	12	6	466	-	694	5	0,37	1,8	2,7	1,8	-	-
	549	676	22,3	12	7,5	472	-	758	6	0,35	1,9	2,9	1,8	-	-
460	505	541	-	7,5	3	473	-	567	2,5	0,17	4	5,9	4	-	-
	516	574	16,7	9	4	475	-	605	3	0,16	4,2	6,3	4	-	-
	533	617	22,3	12	6	483	-	657	5	0,22	3	4,6	2,8	-	-
	524	601	22,3	12	6	483	-	657	5	0,28	2,4	3,6	2,5	-	-
	555	666	22,3	12	7,5	492	-	728	6	0,3	2,3	3,4	2,2	-	-
	536	704	22,3	12	7,5	492	536	728	6	0,3	2,3	3,4	2,2	-	-
	543	649	22,3	12	7,5	492	-	728	6	0,37	1,8	2,7	1,8	-	-
	574	706	22,3	12	7,5	492	-	798	6	0,35	1,9	2,9	1,8	-	-
480	537	602	16,7	9	5	498	-	632	4	0,18	3,8	5,6	3,6	-	-
	549	633	22,3	12	6	503	-	677	5	0,21	3,2	4,8	3,2	-	-
	542	619	22,3	12	6	503	-	677	5	0,28	2,4	3,6	2,5	-	-
	579	692	22,3	12	7,5	512	-	758	6	0,3	2,3	3,4	2,2	-	-
	560	723	22,3	12	7,5	512	560	758	6	0,3	2,3	3,4	2,2	-	-
	564	678	22,3	12	7,5	512	-	758	6	0,37	1,8	2,7	1,8	-	-
	602	741	22,3	12	7,5	512	-	838	6	0,35	1,9	2,9	1,8	-	-

¹⁾ For details about permissible accelerations → [page 779](#)

9.1 Spherical roller bearings

d 500 – 630 mm

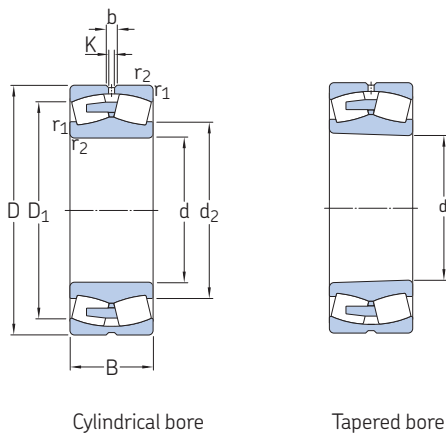

Cylindrical bore

Tapered bore

Principal dimensions			Basic load ratings		Fatigue load limit P_u	Speed ratings		Mass	Designations	
d	D	B	dynamic C	static C_0		Reference speed	Limiting speed		Bearing with cylindrical bore	tapered bore
mm			kN		kN	r/min	kg	–		
500	670	128	2 967	6 000	415	530	950	130	▶ 239/500 CA/W33	239/500 CAK/W33
	720	167	4 358	7 800	510	500	900	225	▶ 230/500 CA/W33	230/500 CAK/W33
	720	218	5 777	11 000	735	430	700	295	240/500 ECA/W33	240/500 ECAK30/W33
	830	264	8 037	12 900	830	380	700	580	231/500 CA/W33	231/500 CAK/W33
	830	325	10 123	17 000	1 120	260	380	700	241/500 ECA/W33	241/500 ECAK30/W33
	920	336	11 183	17 300	1 060	360	500	985	232/500 CA/W33	232/500 CAK/W33
530	650	118	2 124	5 300	380	530	950	86	248/530 CAMA/W20	248/530 CAK30MA/W20
	710	136	3 308	6 700	465	500	900	155	▶ 239/530 CA/W33	239/530 CAK/W33
	780	185	5 267	9 300	610	450	800	310	▶ 230/530 CA/W33	230/530 CAK/W33
	780	250	6 973	13 200	830	400	670	410	▶ 240/530 ECA/W33	240/530 ECAK30/W33
	870	272	8 526	14 000	880	360	670	645	231/530 CA/W33	231/530 CAK/W33
	870	335	10 909	19 000	1 220	240	360	830	241/530 ECA/W33	241/530 ECAK30/W33
560	980	355	13 268	20 400	1 220	320	480	1 200	232/530 CA/W33	232/530 CAK/W33
	750	140	3 571	7 200	500	450	850	175	▶ 239/560 CA/W33	239/560 CAK/W33
	820	195	5 779	10 200	670	430	750	355	230/560 CA/W33	230/560 CAK/W33
	820	258	7 530	14 000	980	20	50	445	240/560 BC	–
	820	258	7 621	14 600	980	380	630	465	240/560 ECA/W33	240/560 ECAK30/W33
	920	280	9 596	16 000	980	340	630	740	231/560 CA/W33	231/560 CAK/W33
600	920	355	12 366	21 600	1 340	220	320	985	241/560 ECJ/W33	241/560 ECK30J/W33
	1 030	365	13 940	22 000	1 320	280	430	1 350	232/560 CA/W33	232/560 CAK/W33
	800	150	4 022	8 300	570	430	750	220	▶ 239/600 CA/W33	▶ 239/600 CAK/W33
	870	200	6 252	11 400	735	400	700	405	230/600 CA/W33	230/600 CAK/W33
	870	272	8 502	16 300	1 100	20	45	519	240/600 BC	–
	870	272	8 580	17 000	1 080	340	560	520	▶ 240/600 ECA/W33	240/600 ECAK30/W33
630	980	300	10 738	18 000	1 100	320	560	895	231/600 CA/W33	231/600 CAK/W33
	980	375	13 522	23 600	1 460	200	300	1 200	241/600 ECA/W33	241/600 ECAK30/W33
	1 090	388	15 652	25 500	1 460	260	400	1 600	232/600 CA/W33	232/600 CAK/W33
	780	112	2 545	6 100	415	430	750	120	238/630 CAMA/W20	–
	850	165	4 744	9 800	630	400	700	280	239/630 CA/W33	▶ 239/630 CAK/W33
	920	212	6 898	12 500	780	380	670	485	▶ 230/630 CA/W33	230/630 CAK/W33
630	920	290	9 150	18 000	1 120	320	530	645	240/630 ECJ/W33	240/630 ECK30J/W33
	920	290	9 307	17 600	1 180	20	45	623	240/630 BC	–
	1 030	315	12 600	20 800	1 220	260	530	1 050	231/630 CA/W33	231/630 CAK/W33
	1 030	400	15 001	27 000	1 630	190	280	1 400	241/630 ECA/W33	241/630 ECAK30/W33

SKF Explorer bearing

▶ Popular item

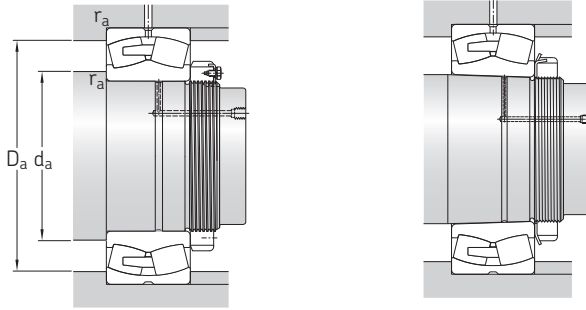

Dimensions					Abutment and fillet dimensions					Calculation factors				Permissible acceleration for oil lubrication ¹⁾	
d	d ₂ ≈	D ₁ ≈	b	K	r _{1,2} min.	d _a min.	d _a max.	D _a max.	r _a max.	e	Y ₁	Y ₂	Y ₀	rotational	linear
mm						mm				-				m/s ²	
500	561	622	22,3	12	5	518	-	652	4	0,17	4	5,9	4	-	-
	573	658	22,3	12	6	523	-	697	5	0,21	3,2	4,8	3,2	-	-
	566	644	22,3	12	6	523	-	697	5	0,26	2,6	3,9	2,5	-	-
	605	726	22,3	12	7,5	532	-	798	6	0,3	2,3	3,4	2,2	-	-
	588	713	22,3	12	7,5	532	-	798	6	0,37	1,8	2,7	1,8	-	-
	633	779	22,3	12	7,5	532	-	888	6	0,35	1,9	2,9	1,8	-	-
530	573	612	-	7,5	3	543	-	637	2,5	0,15	4,5	6,7	4,5	-	-
	594	661	22,3	12	5	548	-	692	4	0,17	4	5,9	4	-	-
	613	710	22,3	12	6	553	-	757	5	0,22	3	4,6	2,8	-	-
	601	687	22,3	12	6	553	-	757	5	0,28	2,4	3,6	2,5	-	-
	638	763	22,3	12	7,5	562	-	838	6	0,3	2,3	3,4	2,2	-	-
	623	748	22,3	12	7,5	562	-	838	6	0,37	1,8	2,7	1,8	-	-
	670	836	22,3	12	9,5	570	-	940	8	0,35	1,9	2,9	1,8	-	-
560	627	697	22,3	12	5	578	-	732	4	0,16	4,2	6,3	4	-	-
	646	746	22,3	12	6	583	-	797	5	0,22	3	4,6	2,8	-	-
	640	739	53,2	15	6	583	-	797	5	0,3	2,3	3,4	2,2	-	-
	637	728	22,3	12	6	583	-	797	5	0,28	2,4	3,6	2,5	-	-
	675	809	22,3	12	7,5	592	-	888	6	0,3	2,3	3,4	2,2	-	-
	634	796	22,3	12	7,5	592	-	888	6	0,35	1,9	2,9	1,8	-	-
	706	878	22,3	12	9,5	600	-	990	8	0,35	1,9	2,9	1,8	-	-
600	671	744	22,3	12	5	618	-	782	4	0,17	4	5,9	4	-	-
	685	789	22,3	12	6	623	-	847	5	0,22	3	4,6	2,8	-	-
	682	784	46,1	15	6	623	-	847	5	0,3	2,3	3,4	2,2	-	-
	675	774	22,3	12	6	623	-	847	5	0,3	2,3	3,4	2,2	-	-
	722	863	22,3	12	7,5	632	-	948	6	0,3	2,3	3,4	2,2	-	-
	702	845	22,3	12	7,5	632	-	948	6	0,37	1,8	2,7	1,8	-	-
	754	929	22,3	12	9,5	640	-	1 050	8	0,35	1,9	2,9	1,8	-	-
630	682	738	-	9	4	645	-	765	3	0,12	5,6	8,4	5,6	-	-
	708	787	22,3	12	6	653	-	827	5	0,17	4	5,9	4	-	-
	727	839	22,3	12	7,5	658	-	892	6	0,21	3,2	4,8	3,2	-	-
	697	823	22,3	12	7,5	658	-	892	6	0,28	2,4	3,6	2,5	-	-
	718	828	56,5	15	7,5	658	-	892	6	0,3	2,3	3,4	2,2	-	-
	755	918	22,3	12	7,5	662	-	998	6	0,3	2,3	3,4	2,2	-	-
	738	885	22,3	12	7,5	662	-	998	6	0,37	1,8	2,7	1,8	-	-

¹⁾ For details about permissible accelerations → [page 779](#)



9.1 Spherical roller bearings

d 670 – 800 mm

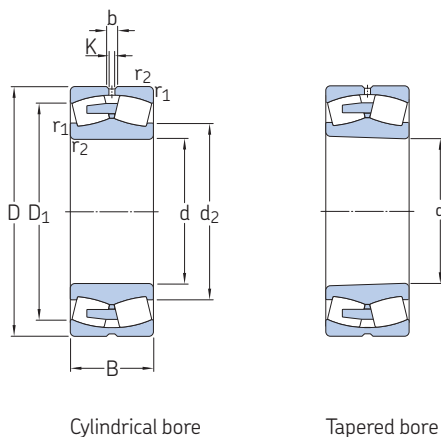

Cylindrical bore

Tapered bore

Principal dimensions			Basic load ratings		Fatigue load limit P_u	Speed ratings		Mass	Designations		
d	D	B	C	C_0		Reference speed	Limiting speed		Bearing with cylindrical bore	tapered bore	
mm			kN		kN	r/min	kg	–			
670	820	112	2 643	6 400	430	400	700	130	238/670 CAMA/W20	–	
	820	150	3 598	9 500	655	400	700	172	248/670 CAMA/W20	–	
	900	170	5 146	10 800	680	360	670	315	239/670 CA/W33	239/670 CAK/W33	
	980	230	7 919	14 600	880	340	600	600	230/670 CA/W33	230/670 CAK/W33	
	980	308	10 435	20 400	1 290	300	500	790	240/670 ECA/W33	240/670 ECAK30/W33	
	1 090	336	13 101	22 400	1 320	240	500	1 250	231/670 CA/W33	231/670 CAK/W33	
	1 090	412	16 381	29 000	1 760	180	260	1 600	241/670 ECA/W33	241/670 ECAK30/W33	
	1 220	438	18 650	30 500	1 700	220	360	2 270	232/670 CA/W33	232/670 CAK/W33	
	710	870	118	3 013	7 500	500	360	670	153	238/710 CAMA/W20	–
		950	180	5 702	12 000	750	340	600	365	239/710 CA/W33	239/710 CAK/W33
950		243	6 860	15 600	930	300	500	495	249/710 CA/W33	249/710 CAK30/W33	
1 030		236	8 669	16 300	965	300	560	670	230/710 CA/W33	230/710 CAK/W33	
1 030		315	11 164	22 800	1 430	260	450	895	▶ 240/710 ECA/W33	240/710 ECAK30/W33	
1 030		315	11 166	22 000	1 430	20	40	843	240/710 BC	–	
1 150		345	14 732	26 000	1 530	240	450	1 450	231/710 CA/W33	231/710 CAK/W33	
1 150		438	17 935	32 500	1 900	160	240	1 900	241/710 ECA/W33	241/710 ECAK30/W33	
1 280		450	21 208	34 500	2 000	200	320	2 610	232/710 CA/W33	232/710 CAK/W33	
750		920	128	3 405	8 500	550	340	600	185	238/750 CAMA/W20	–
	1 000	185	6 138	13 200	800	320	560	420	239/750 CA/W33	239/750 CAK/W33	
	1 000	250	7 699	18 000	1 100	280	480	560	249/750 CA/W33	249/750 CAK30/W33	
	1 090	250	10 061	18 600	1 100	280	530	795	▶ 230/750 CA/W33	230/750 CAK/W33	
	1 090	335	12 235	25 000	1 460	240	430	1 070	▶ 240/750 ECA/W33	240/750 ECAK30/W33	
	1 090	335	12 309	24 500	1 530	20	40	1 010	240/750 BC	–	
	1 220	365	16 518	29 000	1 700	220	430	1 700	231/750 CA/W33	231/750 CAK/W33	
	1 220	475	20 434	37 500	2 160	150	220	2 100	241/750 ECA/W33	241/750 ECAK30/W33	
	800	980	180	4 780	12 900	830	320	560	300	248/800 CAMA/W20	248/800 CAK30MA/W20
		1 060	195	6 595	14 300	865	280	530	470	239/800 CA/W33	239/800 CAK/W33
1 060		258	8 136	19 300	1 060	240	430	640	249/800 CA/W33	249/800 CAK30/W33	
1 150		258	10 335	20 000	1 160	260	480	895	▶ 230/800 CA/W33	230/800 CAK/W33	
1 150		345	13 431	28 500	1 660	220	400	1 200	▶ 240/800 ECA/W33	240/800 ECAK30/W33	
1 150		345	13 447	27 500	1 700	20	40	1 140	240/800 BC	–	
1 280		375	18 033	31 500	1 800	200	400	1 920	231/800 CA/W33	231/800 CAK/W33	
1 280		475	21 587	40 500	2 320	140	200	2 300	241/800 ECA/W33	241/800 ECAK30/W33	
1 420		488	24 973	43 000	2 360	180	280	3 280	232/800 CAF/W33	232/800 CAKF/W33	

SKF Explorer bearing

▶ Popular item

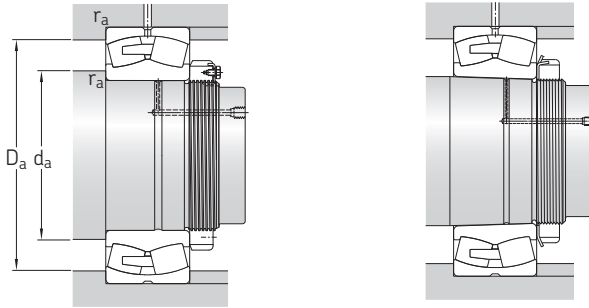

Dimensions					Abutment and fillet dimensions					Calculation factors				Permissible acceleration for oil lubrication ¹⁾	
d	d ₂ ≈	D ₁ ≈	b	K	r _{1,2} min.	d _a min.	d _a max.	D _a max.	r _a max.	e	Y ₁	Y ₂	Y ₀	rotational	linear
mm						mm				-				m/s ²	
670	724	778	-	9	4	685	-	805	3	0,11	6,1	9,1	6,3	-	-
	726	772	-	9	4	685	-	805	3	0,16	4,2	6,3	4	-	-
	752	835	22,3	12	6	693	-	877	5	0,17	4	5,9	4	-	-
	772	892	22,3	12	7,5	698	-	952	6	0,21	3,2	4,8	3,2	-	-
	758	866	22,3	12	7,5	698	-	952	6	0,28	2,4	3,6	2,5	-	-
	804	959	22,3	12	7,5	702	-	1 058	6	0,3	2,3	3,4	2,2	-	-
	782	942	22,3	12	7,5	702	-	1 058	6	0,37	1,8	2,7	1,8	-	-
	832	1 028	22,3	12	12	718	-	1 172	10	0,35	1,9	2,9	1,8	-	-
710	766	826	-	12	4	725	-	855	3	0,11	6,1	9,1	6,3	-	-
	794	882	22,3	12	6	733	-	927	5	0,17	4	5,9	4	-	-
	792	868	22,3	12	6	733	-	927	5	0,22	3	4,6	2,8	-	-
	816	941	22,3	12	7,5	738	-	1 002	6	0,21	3,2	4,8	3,2	-	-
	809	918	22,3	12	7,5	738	-	1 002	6	0,27	2,5	3,7	2,5	-	-
	810	931	61,8	15	7,5	738	-	1 002	6	0,3	2,3	3,4	2,2	-	-
	851	1 017	22,3	12	9,5	750	-	1 110	8	0,28	2,4	3,6	2,5	-	-
	826	989	22,3	12	9,5	750	-	1 110	8	0,37	1,8	2,7	1,8	-	-
	875	1 097	22,3	12	12	758	-	1 232	10	0,35	1,9	2,9	1,8	-	-
750	812	873	-	12	5	768	-	902	4	0,11	6,1	9,1	6,3	-	-
	838	930	22,3	12	6	773	-	977	5	0,16	4,2	6,3	4	-	-
	830	916	22,3	12	6	773	-	977	5	0,22	3	4,6	2,8	-	-
	859	998	22,3	12	7,5	778	-	1 062	6	0,21	3,2	4,8	3,2	-	-
	855	970	22,3	12	7,5	778	-	1 062	6	0,28	2,4	3,6	2,5	-	-
	856	984	72,8	15	7,5	778	-	1 062	6	0,3	2,3	3,4	2,2	-	-
	900	1 080	22,3	12	9,5	790	-	1 180	8	0,28	2,4	3,6	2,5	-	-
	875	1 050	22,3	12	9,5	790	-	1 180	8	0,37	1,8	2,7	1,8	-	-
800	865	921	-	12	5	818	-	962	4	0,15	4,5	6,7	4,5	-	-
	891	986	22,3	12	6	823	-	1 037	5	0,16	4,2	6,3	4	-	-
	887	973	22,3	12	6	823	-	1 037	5	0,21	3,2	4,8	3,2	-	-
	917	1 053	22,3	12	7,5	828	-	1 122	6	0,2	3,4	5	3,2	-	-
	910	1 028	22,3	12	7,5	828	-	1 122	6	0,27	2,5	3,7	2,5	-	-
	911	1 042	66,4	15	7,5	828	-	1 122	6	0,28	2,4	3,6	2,5	-	-
	949	1 141	22,3	12	9,5	840	-	1 240	8	0,28	2,4	3,6	2,5	-	-
	930	1 111	22,3	12	9,5	840	-	1 240	8	0,35	1,9	2,9	1,8	-	-
	995	1 218	22,3	12	15	858	-	1 362	12	0,33	2	3	2	-	-

¹⁾ For details about permissible accelerations → [page 779](#)



9.1 Spherical roller bearings

d 850 – 1 120 mm

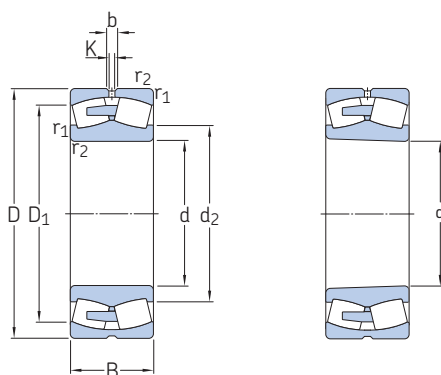

Cylindrical bore

Tapered bore

Principal dimensions			Basic load ratings		Fatigue load limit P_u	Speed ratings		Mass	Designations		
d	D	B	C	C_0		Reference speed	Limiting speed		Bearing with cylindrical bore	tapered bore	
mm			kN		kN	r/min	kg	–			
850	1 030	136	3 882	10 000	630	260	530	240	238/850 CAMA/W20	238/850 CAKMA/W20	
	1 120	200	7 072	15 600	930	260	480	560	239/850 CA/W33	239/850 CAK/W33	
	1 120	272	9 390	22 800	1 370	220	400	740	249/850 CA/W33	249/850 CAK30/W33	
	1 220	272	11 291	21 600	1 250	240	450	1 050	▶ 230/850 CA/W33	230/850 CAK/W33	
	1 220	365	15 078	31 000	1 900	20	40	1 360	240/850 BC	–	
	1 220	365	15 183	31 500	1 900	200	360	1 410	240/850 ECA/W33	240/850 ECAK30/W33	
	1 360	500	23 827	45 000	2 500	130	190	2 770	241/850 ECAF/W33	241/850 ECAK30F/W33	
	1 500	515	27 636	48 000	2 600	160	260	3 940	232/850 CAF/W33	–	
	900	1 090	190	5 428	15 300	950	240	480	370	248/900 CAMA/W20	248/900 CAK30MA/W20
		1 180	206	7 652	17 000	1 000	240	450	605	239/900 CA/W33	239/900 CAK/W33
1 280		280	12 002	23 200	1 320	220	400	1 200	230/900 CA/W33	230/900 CAK/W33	
1 280		375	16 185	34 500	2 040	190	340	1 570	▶ 240/900 ECA/W33	240/900 ECAK30/W33	
1 280		375	16 215	34 000	2 040	20	40	1 520	240/900 BC	–	
1 420		515	25 310	49 000	2 700	120	180	3 350	241/900 ECAF/W33	241/900 ECAK30F/W33	
1 500		515	27 636	48 000	2 600	160	260	3 940	232/850 CAF/W33	–	
950	1 250	224	8 606	19 600	1 120	220	430	755	239/950 CA/W33	239/950 CAK/W33	
	1 250	300	10 701	26 000	1 500	180	340	1 020	249/950 CA/W33	249/950 CAK30/W33	
	1 360	300	14 363	28 500	1 600	200	380	1 450	230/950 CA/W33	230/950 CAK/W33	
	1 360	412	17 847	39 000	2 240	170	300	1 990	240/950 CAF/W33	240/950 CAK30F/W33	
	1 360	412	18 228	38 000	2 240	20	35	1 880	240/950 BC	–	
	1 500	545	27 892	55 000	3 000	110	160	3 540	241/950 ECAF/W33	241/950 ECAK30F/W33	
	1 500	545	27 892	55 000	3 000	110	160	3 540	241/950 ECAF/W33	241/950 ECAK30F/W33	
1 000	1 220	165	5 405	14 300	850	220	400	410	238/1000 CAMA/W20	238/1000 CAKMA/W20	
	1 320	315	11 939	29 000	1 460	170	320	1 200	249/1000 CA/W33	249/1000 CAK30/W33	
	1 420	412	18 592	40 500	2 240	160	280	2 140	240/1000 CAF/W33	240/1000 CAK30F/W33	
	1 580	462	25 650	48 000	2 550	140	280	3 500	231/1000 CAF/W33	231/1000 CAKF/W33	
	1 580	580	31 174	62 000	3 350	100	150	4 300	241/1000 ECAF/W33	241/1000 ECAK30F/W33	
1 060	1 280	165	5 555	15 000	865	200	380	435	238/1060 CAMA/W20	–	
	1 400	250	11 333	26 000	1 430	180	360	1 100	239/1060 CAF/W33	239/1060 CAKF/W33	
	1 400	335	13 354	32 500	1 800	160	280	1 400	249/1060 CAF/W33	249/1060 CAK30F/W33	
	1 500	438	20 724	45 500	2 450	150	260	2 520	240/1060 CAF/W33	240/1060 CAK30F/W33	
1 120	1 460	335	13 718	34 500	1 830	140	260	1 500	249/1120 CAF/W33	249/1120 CAK30F/W33	
	1 580	462	22 364	50 000	2 700	130	240	2 930	240/1120 CAF/W33	240/1120 CAK30F/W33	
	1 580	462	22 936	49 000	2 750	20	35	2 770	240/1120 BC	–	

SKF Explorer bearing

▶ Popular item

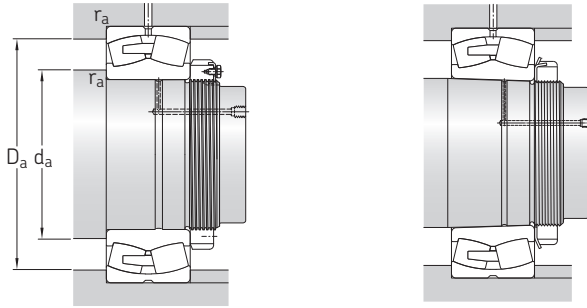

Dimensions					Abutment and fillet dimensions					Calculation factors				Permissible acceleration for oil lubrication ¹⁾	
d	d ₂ ≈	D ₁ ≈	b	K	r _{1,2} min.	d _a min.	d _a max.	D _a max.	r _a max.	e	Y ₁	Y ₂	Y ₀	rota- tional	linear
mm						mm				-				m/s ²	
850	912	981	-	12	5	868	-	1 012	4	0,11	6,1	9,1	6,3	-	-
	946	1 046	22,3	12	6	873	-	1 097	5	0,16	4,2	6,3	4	-	-
	940	1 029	22,3	12	6	873	-	1 097	5	0,22	3	4,6	2,8	-	-
	972	1 117	22,3	12	7,5	878	-	1 192	6	0,2	3,4	5	3,2	-	-
	966	1 105	67,9	15	7,5	878	-	1 192	6	0,28	2,4	3,6	2,5	-	-
	957	1 088	22,3	12	7,5	878	-	1 192	6	0,27	2,5	3,7	2,5	-	-
	988	1 182	22,3	12	12	898	-	1 312	10	0,35	1,9	2,9	1,8	-	-
	1 049	1 284	22,3	12	15	908	-	1 442	12	0,33	2	3	2	-	-
900	969	1 029	-	12	5	918	-	1 072	4	0,14	4,8	7,2	4,5	-	-
	996	1 101	22,3	12	6	923	-	1 157	5	0,15	4,5	6,7	4,5	-	-
	1 025	1 176	22,3	12	7,5	928	-	1 252	6	0,2	3,4	5	3,2	-	-
	1 015	1 149	22,3	12	7,5	928	-	1 252	6	0,26	2,6	3,9	2,5	-	-
	1 024	1 164	69,1	15	7,5	928	-	1 252	6	0,27	2,5	3,7	2,5	-	-
	1 043	1 235	22,3	12	12	948	-	1 372	10	0,35	1,9	2,9	1,8	-	-
950	1 056	1 164	22,3	12	7,5	978	-	1 222	6	0,15	4,5	6,7	4,5	-	-
	1 051	1 150	22,3	12	7,5	978	-	1 222	6	0,21	3,2	4,8	3,2	-	-
	1 086	1 246	22,3	12	7,5	978	-	1 332	6	0,2	3,4	5	3,2	-	-
	1 077	1 214	22,3	12	7,5	978	-	1 332	6	0,27	2,5	3,7	2,5	-	-
	1 076	1 230	85,9	15	7,5	978	-	1 332	6	0,3	2,3	3,4	2,2	-	-
	1 102	1 305	22,3	12	12	998	-	1 452	10	0,35	1,9	2,9	1,8	-	-
1 000	1 079	1 161	-	12	6	1 023	-	1 197	5	0,12	5,6	8,4	5,6	-	-
	1 109	1 212	22,3	12	7,5	1 028	-	1 292	6	0,21	3,2	4,8	3,2	-	-
	1 136	1 278	22,3	12	7,5	1 028	-	1 392	6	0,26	2,6	3,9	2,5	-	-
	1 185	1 403	22,3	12	12	1 048	-	1 532	10	0,28	2,4	3,6	2,5	-	-
	1 159	1 373	22,3	12	12	1 048	-	1 532	10	0,35	1,9	2,9	1,8	-	-
1 060	1 137	1 219	-	12	6	1 083	-	1 257	5	0,11	6,1	9,1	6,3	-	-
	1 171	1 305	22,3	12	7,5	1 088	-	1 372	6	0,16	4,2	6,3	4	-	-
	1 168	1 286	22,3	12	7,5	1 088	-	1 372	6	0,21	3,2	4,8	3,2	-	-
	1 199	1 349	22,3	12	9,5	1 094	-	1 466	8	0,26	2,6	3,9	2,5	-	-
1 120	1 231	1 350	22,3	12	7,5	1 148	-	1 432	6	0,2	3,4	5	3,2	-	-
	1 268	1 423	22,3	12	9,5	1 154	-	1 546	8	0,26	2,6	3,9	2,5	-	-
	1 259	1 436	104	15	9,5	1 154	-	1 546	8	0,28	2,4	3,6	2,5	-	-

¹⁾ For details about permissible accelerations → [page 779](#)



9.1 Spherical roller bearings

d 1 180 – 1 800 mm

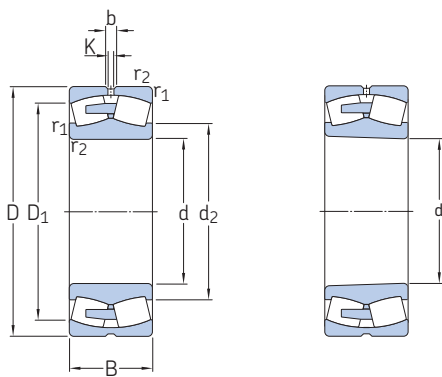

Cylindrical bore

Tapered bore

Principal dimensions			Basic load ratings		Fatigue load limit P_u	Speed ratings		Mass	Designations	
d	D	B	dynamic C	static C_0		Reference speed	Limiting speed		Bearing with cylindrical bore	tapered bore
mm			kN		kN	r/min		kg	–	
1 180	1 420	180	6 778	18 600	1 080	170	320	575	238/1180 CAFA/W20	238/1180 CAKFA/W20
	1 540	272	13 076	31 000	1 660	150	300	1 400	239/1180 CAF/W33	239/1180 CAKF/W33
	1 540	355	15 751	40 500	2 160	130	240	1 800	249/1180 CAF/W33	249/1180 CAK30F/W33
	1 660	475	25 471	58 500	3 050	130	220	3 320	240/1180 CAF/W33	240/1180 CAK30F/W33
1 250	1 750	375	21 256	45 000	2 320	130	240	2 840	230/1250 CAF/W33	230/1250 CAKF/W33
1 320	1 720	400	18 714	49 000	2 500	110	200	2 500	249/1320 CAF/W33	249/1320 CAK30F/W33
1 500	1 820	315	14 684	45 000	2 400	110	220	1 710	248/1500 CAFA/W20	248/1500 CAK30FA/W20
1 800	2 180	375	20 274	63 000	3 050	75	140	2 900	248/1800 CAFA/W20	248/1800 CAK30FA/W20

9.1



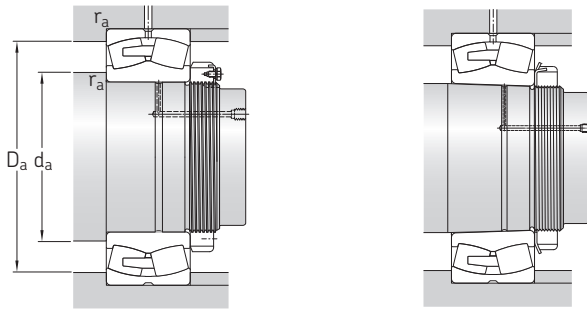

Dimensions					Abutment and fillet dimensions					Calculation factors				Permissible acceleration for oil lubrication ¹⁾	
d	d ₂ ≈	D ₁ ≈	b	K	r _{1,2} min.	d _a min.	d _a max.	D _a max.	r _a max.	e	Y ₁	Y ₂	Y ₀	rotational	linear
mm						mm				-				m/s ²	
1180	1 264	1 355	-	12	6	1 203	-	1 397	5	0,11	6,1	9,1	6,3	-	-
	1 305	1 439	22,3	12	7,5	1 208	-	1 512	6	0,16	4,2	6,3	4	-	-
	1 297	1 422	22,3	12	7,5	1 208	-	1 512	6	0,2	3,4	5	3,2	-	-
	1 325	1 507	22,3	12	9,5	1 200	-	1 626	8	0,26	2,6	3,9	2,5	-	-
1250	1 415	1 611	22,3	12	9,5	1 284	-	1 716	8	0,19	3,6	5,3	3,6	-	-
1320	1 449	1 589	22,3	12	7,5	1 348	-	1 692	6	0,21	3,2	4,8	3,2	-	-
1500	1 612	1 719	-	12	7,5	1 528	-	1 792	6	0,15	4,5	6,7	4,5	-	-
1800	1 932	2 060	-	12	9,5	1 834	-	2 146	8	0,15	4,5	6,7	4,5	-	-

¹⁾ For details about permissible accelerations → [page 779](#)



9.2 Spherical roller bearings on an adapter sleeve

d_1 20 – 100 mm

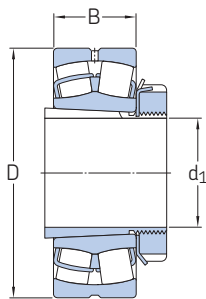

Bearing on an
H.. sleeve

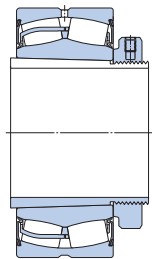

Sealed bearing on
an H.. E sleeve

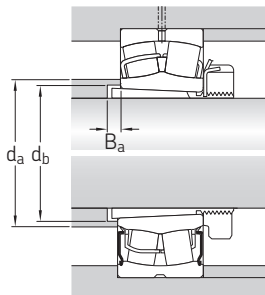

Principal dimensions			Abutment and fillet dimensions			Mass Bearing + sleeve	Designations Bearing ¹⁾	Sleeve ²⁾
d_1	D	B	d_a max.	d_b min.	B_a min.			
mm			mm			kg	–	
20	52	18	31	28	5	0,33	▶ 22205 EK	H 305
25	62	20	37	33	5	0,39	▶ 22206 EK	H 306
30	72	23	44	39	5	0,59	▶ 22207 EK	H 307
35	80	23	49	44	5	0,68	▶ 22208 EK	H 308
	80	28	47	44	8	0,8	▶ BS2-2208-2RSK/VT143	H 2308 E
	90	23	60	44	5	0,92	▶ 21308 EK	H 308
40	90	33	49	45	6	1,25	▶ 22308 EK	H 2308
	85	23	54	50	7	0,81	▶ 22209 EK	H 309
	85	28	52	48	0	0,9	▶ BS2-2209-2RSK/VT143	H 309 E
45	100	25	65	50	5	1,2	▶ 21309 EK	H 309
	100	36	57	50	6	1,7	▶ 22309 EK	H 2309
	90	23	60	55	9	0,9	▶ 22210 EK	H 310
50	90	28	58	54	2	1	▶ BS2-2210-2RSK/VT143	H 310 E
	110	27	72	55	6	1,6	▶ 21310 EK	H 310
	110	40	63	56	5	2,25	▶ 22310 EK	H 2310
55	100	25	65	60	10	1,1	▶ 22211 EK	H 311
	100	31	63	59	2	1,3	▶ BS2-2211-2RSK/VT143	H 311 E
	120	29	72	60	6	1,95	▶ 21311 EK	H 311
55	120	43	70	61	6	2,85	▶ 22311 EK	H 2311
	110	28	72	65	9	1,45	▶ 22212 EK	H 312
	110	34	69	64	1	1,7	▶ BS2-2212-2RSK/VT143	H 312 E
55	130	31	87	65	6	2,35	▶ 21312 EK	H 312
	130	46	77	66	6	3,5	▶ 22312 EK	H 2312

SKF Explorer bearing

▶ Popular item

¹⁾ For additional bearing data → [product table, page 792](#)

²⁾ For additional adapter sleeve data → [product table, page 1072](#)

Principal dimensions			Abutment and fillet dimensions			Mass Bearing + sleeve	Designations Bearing ¹⁾	Sleeve ²⁾	
d ₁	D	B	d _a max.	d _b min.	B _a min.				
mm			mm			kg	–		
60	120	31	80	70	8	1,95	▶ 22213 EK BS2-2213-2RSK/VT143 ▶ 22214 EK	H 313 H 2313 E H 314	
	120	38	76	70	14	2,1			
	125	31	83	75	9	2,15			
		125	38	80	74	1	2,4	BS2-2214-2RSK/VT143 ▶ 21313 EK ▶ 22313 EK	H 314 E H 313 H 2313
		140	33	94	70	6	2,9		
		140	48	81	72	5	4,2		
	150	35	101	75	6	3,7	▶ 21314 EK ▶ 22314 EK	H 314 H 2314	
	150	51	90	76	6	5,35			
65	130	31	87	80	12	2,45	▶ 22215 EK ▶ BS2-2215-2RSK/VT143 ▶ 21315 EK	H 315 H 315 E H 315	
	130	38	84	80	3	2,8			
	160	37	101	80	6	4,5			
		160	55	92	82	5	6,5	▶ 22315 EK	H 2315
70	140	33	94	85	12	3	▶ 22216 EK ▶ BS2-2216-2RSK/VT143 ▶ 21316 EK	H 316 H 316 E H 316	
	140	40	91	85	2,5	3,3			
	170	39	106	85	6	5,3			
	170	58	98	88	6	7,65	▶ 22316 EK	H 2316	
75	150	36	101	91	12	3,7	▶ 22217 EK ▶ BS2-2217-2RSK/VT143 ▶ 21317 EK	H 317 H 317 E H 317	
	150	44	98	90	1,5	4,1			
	180	41	106	91	7	6,2			
	180	60	108	94	7	8,85	▶ 22317 EK	H 2317	
80	160	40	106	96	10	4,55	▶ 22218 EK ▶ BS2-2218-2RSK/VT143 ▶ 23218 CCK/W33	H 318 H 2318 E/L73 H 2318	
	160	48	102	97	7,5	5,1			
	160	52,4	106	100	18	6			
	190	43	112	96	7	7,25	▶ 21318 EK ▶ 22318 EK	H 318 H 2318	
	190	64	113	100	7	10,5			
85	170	43	112	102	9	5,45	▶ 22219 EK ▶ 21319 EK ▶ 22319 EK	H 319 H 319 H 2319	
	200	45	118	102	7	8,25			
	200	67	118	105	7	12			
90	165	52	115	107	6	6,15	▶ 23120 CCK/W33 ▶ 22220 EK BS2-2220-2RS5K/VT143	H 3120 H 320 H 2320 E	
	180	46	118	108	8	6,4			
	180	55	114	108	22,5	7,4			
	180	60,3	117	110	19	8,75	▶ 23220 CCK/W33 ▶ 21320 EK ▶ 22320 EK	H 2320 H 320 H 2320	
	215	47	118	108	7	10,5			
	215	73	130	110	7	15			
100	170	45	125	118	14	5,75	▶ 23022 CCK/W33 ▶ 23122-2CS5K/VT143 ▶ 23122 CCK/W33	H 322 H 3122 E H 3122	
	180	56	122	65	9	7,7			
	180	56	126	117	7	7,7			
	200	53	130	118	6	8,9	▶ 22222 EK BS2-2222-2RS5K/VT143 23222-2CS5K/VT143	H 322 H 2322 E H 2322 E	
	200	63	126	118	21,5	10			
	200	69,8	126	121	17	12,5			
	200	69,8	130	121	17	12,5	▶ 23222 CCK/W33 ▶ 22322 EK	H 2322 H 2322	
	240	80	143	121	7	21			

SKF Explorer bearing

▶ Popular item

¹⁾ For additional bearing data → [product table, page 792](#)

²⁾ For additional adapter sleeve data → [product table, page 1072](#)



9.2 Spherical roller bearings on an adapter sleeve

d_1 110 – 170 mm

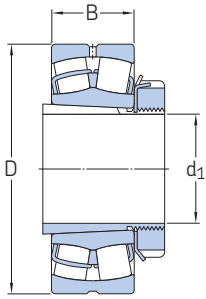

Bearing on an H.. sleeve

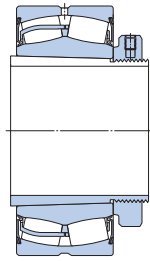

Sealed bearing on an H.. E sleeve

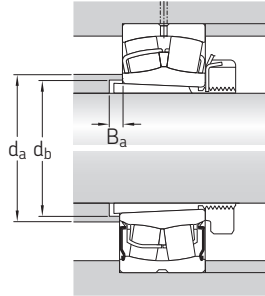

Principal dimensions			Abutment and fillet dimensions			Mass Bearing + sleeve	Designations Bearing ¹⁾	Sleeve ²⁾	
d_1	D	B	d_a max.	d_b min.	B_a min.				
mm			mm			kg	–		
110	180	46	135	127	7	5,95	▶ 23024 CCK/W33	H 3024	
	200	62	139	128	7	10	▶ 23124 CCK/W33	H 3124	
	215	58	141	128	11	11	▶ 22224 EK	H 3124	
	215	69	136	129	21,5	12,5	BS2-2224-2RS5K/VT143	H 2324 EH	
	215	76	137	131	17	14,5	▶ 23224-2CS5K/VT143	H 2324 L	
	215	76	141	131	17	14,5	▶ 23224 CCK/W33	H 2324	
	260	86	147	131	7	25,5	▶ 22324-2CS5K/VT143	H 2324	
	260	86	152	131	7	25,5	▶ 22324 CCK/W33	H 2324	
115	200	52	145	137	8	8,7	BS2-2306-2CS5K/VT143	H 3026 E	
	200	52	148	137	8	8,6	▶ 23026 CCK/W33	H 3026	
	210	64	148	138	8	12	▶ 23126 CCK/W33	H 3126	
	230	64	152	138	8	14	▶ 22226 EK	H 3126	
	230	75	147	139	23,5	14,5	BS2-2226-2CS5K/VT143	H 2326 L	
	230	80	147	142	21	18	23226-2CS5K/VT143	H 2326 L	
	230	80	151	142	21	18,5	▶ 23226 CCK/W33	H 2326	
	280	93	159	142	8	33	▶ 22326-2CS5K/VT143	H 2326	
	280	93	164	142	8	33	▶ 22326 CCK/W33	H 2326	
125	210	53	155	147	8	9,4	BS2-2308-2CS5K/VT143	H 3028 E	
	210	53	158	147	8	9,4	▶ 23028 CCK/W33	H 3028	
	225	68	159	149	8	14,5	▶ 23128 CCK/W33	H 3128	
	250	68	161	149	8	17,5	▶ 22228-2CS5K/VT143	H 3128 L	
	250	68	166	149	8	18	▶ 22228 CCK/W33	H 3128	
	250	88	161	152	22	24	▶ 23228-2CS5K/VT143	H 2328	
	250	88	165	152	22	24	▶ 23228 CCK/W33	H 2328	
	300	102	169	152	8	41	▶ 22328-2CS5K/VT143	H 2328	
	300	102	175	152	8	41	▶ 22328 CCK/W33	H 2328	

9.2



SKF Explorer bearing

▶ Popular item

¹⁾ For additional bearing data → [product table, page 792](#)

²⁾ For additional adapter sleeve data → [product table, page 1072](#)

Principal dimensions			Abutment and fillet dimensions			Mass Bearing + sleeve	Designations Bearing ¹⁾	Sleeve ²⁾	
d ₁	D	B	d _a max.	d _b min.	B _a min.				
mm			mm			kg	–		
135	225	56	165	158	8	11,5	23030-2CS5K/VT143	H 3030 E	
	225	56	169	158	8	11	▶ 23030 CCK/W33	H 3030	
	250	80	168	160	8	20	23130-2CS5K/VT143	H 3130 E	
	250	80	172	160	8	21	▶ 23130 CCK/W33	H 3130	
	270	73	174	160	15	23	▶ 22230-2CS5K/VT143	H 3130	
	270	73	178	160	15	23	▶ 22230 CCK/W33	H 3130	
	270	96	171	163	20	30	23230-2CS5K/VT143	H 2330 L	
	270	96	175	163	20	30	▶ 23230 CCK/W33	H 2330	
	320	108	181	163	8	49	▶ 22330-2CS5K/VT143	H 2330	
	320	108	188	163	8	47,5	▶ 22330 CCK/W33	H 2330	
140	240	60	177	168	9	14,5	23032-2CS5K/VT143	H 3032 E	
	240	60	180	168	9	14,5	▶ 23032 CCK/W33	H 3032	
	270	86	180	170	8	27,5	23132-2CS5K/VT143	H 3132 E	
	270	86	184	170	8	27,5	▶ 23132 CCK/W33	H 3132	
	290	80	185	170	14	29,5	▶ 22232-2CS5K/VT143	H 3132	
	290	80	191	170	14	29,5	▶ 22232 CCK/W33	H 3132	
	290	104	188	174	18	39	▶ 23232 CCK/W33	H 2332	
	340	114	193	174	8	60	▶ 22332-2CS5K/VT143	H 2332	
	340	114	200	174	8	60	▶ 22332 CCK/W33	H 2332	
	150	260	67	188	179	9	18,5	23034-2CS5K/VT143	H 3034 E
260		67	191	179	9	18,5	▶ 23034 CCK/W33	H 3034	
280		88	190	180	8	29,5	23134-2CS5K/VT143	H 3134 E	
280		88	195	180	8	29,5	▶ 23134 CCK/W33	H 3134	
310		86	198	180	10	36	▶ 22234-2CS5K/VT143	H 3134	
310		86	203	180	10	36	▶ 22234 CCK/W33	H 3134	
310		110	200	185	18	46,5	▶ 23234 CCK/W33	H 2334	
360		120	213	185	8	69,5	▶ 22334 CCK/W33	H 2334	
160		250	52	199	188	9	13,5	23936 CCK/W33	H 3936
		280	74	199	189	9	23	23036-2CS5K/VT143	H 3036 E
	280	74	204	189	9	23	▶ 23036 CCK/W33	H 3036	
	300	96	202	191	8	35	23136-2CS5K/VT143	H 3136 L	
	300	96	207	191	8	37	▶ 23136 CCK/W33	H 3136	
	320	86	208	191	18	37,5	▶ 22236-2CS5K/VT143	H 3136	
	320	86	213	191	18	38	▶ 22236 CCK/W33	H 3136	
	320	112	211	195	22	49,5	▶ 23236 CCK/W33	H 2336	
	380	126	224	195	8	80	▶ 22336 CCK/W33	H 2336	
	170	260	52	209	198	10	14,5	23938 CCK/W33	H 3938
290		75	216	199	10	25	▶ 23038 CCK/W33	H 3038	
320		104	215	202	9	44,5	▶ 23138-2CS5K/VT143	H 3138	
320		104	220	202	9	44,5	▶ 23138 CCK/W33	H 3138	
340		92	220	202	21	44,5	▶ 22238-2CS5K/VT143	H 3138	
340		92	225	202	21	46	▶ 22238 CCK/W33	H 3138	
340		120	222	206	21	59	▶ 23238 CCK/W33	H 2338	
400		132	236	206	9	93	▶ 22338 CCK/W33	H 2338	

SKF Explorer bearing

▶ Popular item

¹⁾ For additional bearing data → [product table, page 792](#)

²⁾ For additional adapter sleeve data → [product table, page 1072](#)



9.2 Spherical roller bearings on an adapter sleeve

d_1 180 – 380 mm

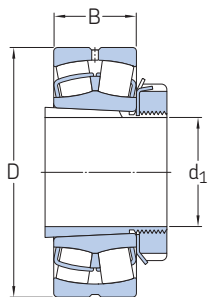

Bearing on an
H.. sleeve

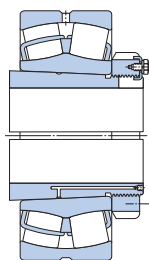

Bearing on an
OH..H sleeve

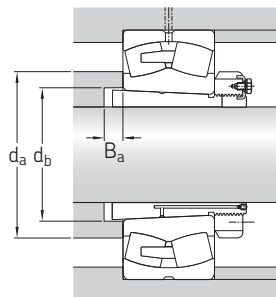

Principal dimensions			Abutment and fillet dimensions			Mass Bearing + sleeve	Designations Bearing ¹⁾	Sleeve ²⁾
d_1	D	B	d_a max.	d_b min.	B_a min.			
mm			mm			kg	–	
180	280	60	222	208	10	19	23940 CCK/W33	H 3940
	310	82	223	210	10	30	▶ 23040-2CS5K/VT143	H 3040
	310	82	228	210	10	31,5	▶ 23040 CCK/W33	H 3040
	340	112	227	212	9	53,5	▶ 23140-2CS5K/VT143	H 3140
	340	112	231	212	9	55,5	▶ 23140 CCK/W33	H 3140
	360	98	232	212	24	53	▶ 22240-2CS5K/VT143	H 3140
	360	98	238	212	24	66	▶ 22240 CCK/W33	H 3140
	360	128	229	216	19	69,5	23240-2CS5K/VT143	H 2340 L
	360	128	235	216	19	70	▶ 23240 CCK/W33	H 2340
	420	138	249	216	9	107	▶ 22340 CCK/W33	H 2340
200	300	60	241	229	12	22,5	23944 CCK/W33	OH 3944 H
	340	90	245	231	10	38	▶ 23044-2CS5K/VT143	OH 3044 H
	340	90	250	231	10	39,5	▶ 23044 CCK/W33	OH 3044 H
	370	120	249	233	10	66,5	23144-2CS5K/VT143	OH 3144 HTL
	370	120	255	233	10	67,5	▶ 23144 CCK/W33	OH 3144 H
	400	108	257	233	21	71,5	▶ 22244-2CS5K/VT143	OH 3144 H
	400	108	263	233	21	74	▶ 22244 CCK/W33	OH 3144 H
	400	144	259	236	11	96,5	▶ 23244 CCK/W33	OH 2344 H
	460	145	270	236	10	131	▶ 22344-2CS5K/VT143	OH 2344 H
	460	145	279	236	10	135	▶ 22344 CCK/W33	OH 2344 H
220	320	60	261	249	12	24,5	23948 CCK/W33	OH 3948 H
	360	92	265	251	11	42,5	23048-2CS5K/VT143	OH 3048 HE
	360	92	271	251	11	44,5	▶ 23048 CCK/W33	OH 3048 H
	400	128	270	254	11	79,5	23148-2CS5K/VT143	OH 3148 HTL
	400	128	277	254	11	80,5	▶ 23148 CCK/W33	OH 3148 H
	440	120	290	254	19	99	▶ 22248 CCK/W33	OH 3148 H
	440	160	286	257	6	125	23248 CCK/W33	OH 2348 H
	500	155	303	257	11	170	22348 CCK/W33	OH 2348 H

SKF Explorer bearing

▶ Popular item

¹⁾ For additional bearing data → [product table, page 792](#)

²⁾ For additional adapter sleeve data → [product table, page 1072](#)

Principal dimensions			Abutment and fillet dimensions			Mass Bearing + sleeve	Designations Bearing ¹⁾	Sleeve ²⁾		
d ₁	D	B	d _a max.	d _b min.	B _a min.					
mm			mm			kg	–			
240	360	75	287	270	12	35	23952 CCK/W33 23052-2CS5K/VT143 ▶ 23052 CCK/W33	OH 3952 H OH 3052 HE OH 3052 H		
	400	104	289	272	11	58				
	400	104	295	272	11	60,5				
		440	144	293	276	11	105	▶ 23152-2CS5K/VT143 ▶ 23152 CCK/W33 22252 CCK/W33	OH 3152 HTL OH 3152 H OH 3152 H	
		440	144	301	276	11	109			
		480	130	312	276	25	130			
		480	174	312	278	2	160	▶ 23252 CCK/W33 ▶ 22352 CCK/W33	OH 2352 H OH 2352 H	
		540	165	328	278	11	215			
	260	380	75	308	290	12	40	23956 CCK/W33 ▶ 23056 CCK/W33 23156-2CS5K/VT143	OH 3956 H OH 3056 H OH 3156 HTL	
		420	106	315	292	12	67			
		460	146	314	296	12	114			
			460	146	321	296	12	115	▶ 23156 CCK/W33 22256 CCK/W33 ▶ 23256 CCK/W33	OH 3156 H OH 3156 H OH 2356 H
500			130	333	296	28	135			
500			176	332	299	11	165			
		580	175	354	299	12	250	▶ 22356 CCK/W33	OH 2356 H	
		280	420	90	333	312	13	58,5	23960 CCK/W33 ▶ 23060 CCK/W33 23160-2CS5K/VT143	OH 3960 H OH 3060 H OH 3160 HE
460			118	340	313	12	90			
500			160	337	318	12	153			
			500	160	345	318	12	150	▶ 23160 CCK/W33 22260 CCK/W33 ▶ 23260 CCK/W33	OH 3160 H OH 3160 H OH 3260 H
			540	140	354	318	32	170		
	540		192	356	321	12	210			
300	440	90	354	332	13	61	23964 CCK/W33 ▶ 23064 CCK/W33 ▶ 23164-2CS5K/VT143	OH 3964 H OH 3064 H OH 3164 H		
	480	121	360	334	13	97				
	540	176	361	338	13	192				
		540	176	370	338	13	185	▶ 23164 CCK/W33 22264 CCK/W33 23264 CCK/W33	OH 3164 H OH 3164 H OH 3264 H	
		580	150	379	338	39	200			
		580	208	382	343	13	260			
	320	460	90	373	352	14	67,5	23968 CCK/W33 ▶ 23068 CCK/W33 23168-2CS5K/VT143	OH 3968 H OH 3068 H OH 3168 HE	
		520	133	385	355	14	130			
		580	190	385	360	14	252			
			580	190	394	360	14	250	▶ 23168 CCK/W33 ▶ 23268 CAK/W33	OH 3168 H OH 3268 H
			620	224	427	364	14	335		
		340	480	90	394	372	14	70,5	23972 CCK/W33 ▶ 23072 CCK/W33 23172-2CS5K/VT143	OH 3972 H OH 3072 H OH 3172 HE
540	134		404	375	14	135				
600	192		408	380	14	265				
	600		192	418	380	14	260	▶ 23172 CCK/W33 22272 CAK/W33 23272 CAK/W33	OH 3172 H OH 3172 H OH 3272 H	
	650		170	454	380	36	375			
	650		232	449	385	14	375			
360	520		106	419	393	15	95	23976 CCK/W33 ▶ 23076 CCK/W33 ▶ 23176 CAK/W33	OH 3976 H OH 3076 H OH 3176 H	
	560		135	426	396	15	145			
	620		194	454	401	15	275			
			680	240	473	405	15	420	23276 CAK/W33	OH 3276 H
			380	540	106	439	413	15	100	23980 CCK/W33 23080 CCK/W33 23180-2CS5K/VT143
	600			148	450	417	15	180		
650	200	458		421	15	312				
	650	200		475	421	15	325	▶ 23180 CAK/W33 23280 CAK/W33 22380 CAK/W33	OH 3180 H OH 3280 H OH 3280 H	
	720	256		500	427	15	505			
	820	243		534	427	28	735			

SKF Explorer bearing

▶ Popular item

¹⁾ For additional bearing data → [product table, page 792](#)

²⁾ For additional adapter sleeve data → [product table, page 1072](#)



9.2 Spherical roller bearings on an adapter sleeve

d_1 400 – 1 000 mm

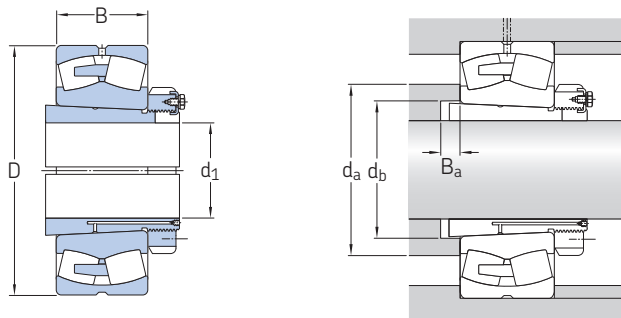

Principal dimensions			Abutment and fillet dimensions			Mass Bearing + sleeve	Designations Bearing ¹⁾	Sleeve ²⁾
d_1	D	B	d_a max.	d_b min.	B_a min.			
mm			mm			kg	–	
400	560	106	459	433	15	105	23984 CCK/W33	OH 3984 H
	620	150	487	437	16	190	23084 CAK/W33	OH 3084 H
	700	224	483	443	16	410	▶ 23184 CKJ/W33	OH 3184 H
	760	272	526	446	16	590	23284 CAK/W33	OH 3284 H
410	600	118	484	454	17	150	23988 CCK/W33	OH 3988 H
	650	157	511	458	17	235	23088 CAK/W33	OH 3088 H
	720	226	529	463	17	430	23188 CAK/W33	OH 3188 H
	790	280	549	469	17	670	23288 CAK/W33	OH 3288 H
430	620	118	516	474	17	160	23992 CAK/W33	OH 3992 H
	680	163	533	478	17	265	23092 CAK/W33	OH 3092 H
	760	240	555	484	17	530	23192 CAK/W33	OH 3192 H
	830	296	574	490	17	790	23292 CAK/W33	OH 3292 H
450	650	128	537	496	18	185	23996 CAK/W33	OH 3996 H
	700	165	549	499	18	275	23096 CAK/W33	OH 3096 H
	790	248	579	505	18	590	23196 CAK/W33	OH 3196 H
	870	310	602	512	18	935	23296 CAK/W33	OH 3296 H
470	670	128	561	516	18	195	239/500 CAK/W33	OH 39/500 H
	720	167	573	519	18	290	230/500 CAK/W33	OH 30/500 H
	830	264	605	527	18	690	231/500 CAK/W33	OH 31/500 H
	920	336	633	534	18	1 100	232/500 CAK/W33	OH 32/500 H
500	710	136	594	547	20	255	239/530 CAK/W33	OH 39/530 H
	780	185	613	551	20	405	230/530 CAK/W33	OH 30/530 H
	870	272	638	558	20	785	231/530 CAK/W33	OH 31/530 H
	980	355	670	566	20	1 360	232/530 CAK/W33	OH 32/530 H
530	750	140	627	577	20	260	239/560 CAK/W33	OH 39/560 H
	820	195	646	582	20	445	230/560 CAK/W33	OH 30/560 H
	920	280	675	589	20	880	231/560 CAK/W33	OH 31/560 H
	1 030	365	706	595	20	1 490	232/560 CAK/W33	OH 32/560 H

SKF Explorer bearing

▶ Popular item

¹⁾ For additional bearing data → [product table, page 792](#)

²⁾ For additional adapter sleeve data → [product table, page 1072](#)

Principal dimensions			Abutment and fillet dimensions			Mass Bearing + sleeve	Designations Bearing ¹⁾	Sleeve ²⁾
d ₁	D	B	d _a max.	d _b min.	B _a min.			
mm			mm			kg	–	
560	800	150	671	619	22	330	239/600 CAK/W33	OH 39/600 H
	870	200	685	623	22	525	230/600 CAK/W33	OH 30/600 H
	980	300	722	629	22	1 070	231/600 CAK/W33	OH 31/600 H
	1 090	388	754	639	22	1 780	232/600 CAK/W33	OH 32/600 H
600	850	165	708	650	22	385	239/630 CAK/W33	OH 39/630 H
	920	212	727	654	22	595	230/630 CAK/W33	OH 30/630 H
	1 030	315	755	663	22	1 240	231/630 CAK/W33	OH 31/630 H
630	900	170	752	691	22	455	239/670 CAK/W33	OH 39/670 H
	980	230	772	696	22	755	230/670 CAK/W33	OH 30/670 H
	1 090	336	804	705	22	1 510	231/670 CAK/W33	OH 31/670 H
	1 220	438	832	711	22	2 540	232/670 CAK/W33	OH 32/670 H
670	950	180	794	732	26	525	239/710 CAK/W33	OH 39/710 H
	1 030	236	816	736	26	860	230/710 CAK/W33	OH 30/710 H
	1 150	345	851	745	26	1 750	231/710 CAK/W33	OH 31/710 H
	1 280	450	875	753	26	3 000	232/710 CAK/W33	OH 32/710 H
710	1 000	185	838	772	26	605	239/750 CAK/W33	OH 39/750 H
	1 090	250	859	778	26	990	230/750 CAK/W33	OH 30/750 H
	1 220	365	900	787	26	2 050	231/750 CAK/W33	OH 31/750 H
750	1 060	195	891	822	28	730	239/800 CAK/W33	OH 39/800 H
	1 150	258	917	829	28	1 200	230/800 CAK/W33	OH 30/800 H
	1 280	375	949	838	28	2 430	231/800 CAK/W33	OH 31/800 H
800	1 120	200	946	872	28	950	239/850 CAK/W33	OH 39/850 H
	1 220	272	972	880	28	1 390	230/850 CAK/W33	OH 30/850 H
850	1 180	206	996	924	30	930	239/900 CAK/W33	OH 39/900 H
	1 280	280	1 025	931	30	1 580	230/900 CAK/W33	OH 30/900 H
900	1 250	224	1 056	976	30	1 120	239/950 CAK/W33	OH 39/950 H
	1 360	300	1 086	983	30	1 870	230/950 CAK/W33	OH 30/950 H
950	1 580	462	1 185	1 047	33	4 340	231/1000 CAKF/W33	OH 31/1000 H
1 000	1 400	250	1 179	1 087	33	1 590	239/1060 CAKF/W33	OH 39/1060 H



9.3 Spherical roller bearings on a withdrawal sleeve

d_1 35 – 145 mm

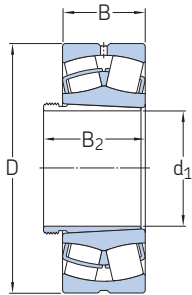

Principal dimensions				Mass	Designations	Sleeve ²⁾
d_1	D	B	$B_2^{3)}$	Bearing + sleeve	Bearing ¹⁾	
mm			≈	kg	–	
35	80	23	32	0,6	▶ 22208 EK	AH 308
	90	23	32	0,84	▶ 21308 EK	AH 308
	90	33	43	1,2	▶ 22308 EK	AH 2308
40	85	23	34	0,7	▶ 22209 EK	AH 309
	100	25	34	1,1	▶ 21309 EK	AH 309
	100	36	47	1,55	▶ 22309 EK	AH 2309
45	90	23	38	0,75	▶ 22210 EK	AHX 310
	110	27	38	1,45	▶ 21310 EK	AHX 310
	110	40	53	2,1	▶ 22310 EK	AHX 2310
50	100	25	40	0,95	▶ 22211 EK	AHX 311
	120	29	40	1,8	▶ 21311 EK	AHX 311
	120	43	57	2,7	▶ 22311 EK	AHX 2311
55	110	28	43	1,3	▶ 22212 EK	AHX 312
	130	31	43	2,2	▶ 21312 EK	AHX 312
	130	46	61	3,3	▶ 22312 EK	AHX 2312
60	120	31	45	1,7	▶ 22213 EK	AH 313 G
	140	33	45	2,75	▶ 21313 EK	AH 313 G
	140	48	64	4,1	▶ 22313 EK	AH 2313 G
65	125	31	47	1,8	▶ 22214 EK	AH 314 G
	150	35	47	3,35	▶ 21314 EK	AH 314 G
	150	51	68	4,9	▶ 22314 EK	AHX 2314 G
70	130	31	49	1,95	▶ 22215 EK	AH 315 G
	160	37	49	4,15	▶ 21315 EK	AH 315 G
	160	55	72	6	▶ 22315 EK	AHX 2315 G
75	140	33	52	2,4	▶ 22216 EK	AH 316
	170	39	52	4,75	▶ 21316 EK	AH 316
	170	58	75	7	▶ 22316 EK	AHX 2316
80	150	36	56	3,05	▶ 22217 EK	AHX 317
	180	41	56	5,55	▶ 21317 EK	AHX 317
	180	60	78	8,15	▶ 22317 EK	AHX 2317
85	160	40	57	3,7	▶ 22218 EK	AHX 318
	160	52,4	67	5	▶ 23218 CCK/W33	AHX 3218
	190	43	57	6,4	▶ 21318 EK	AHX 318
	190	64	83	9,5	▶ 22318 EK	AHX 2318

SKF Explorer bearing

▶ Popular item

¹⁾ For additional bearing data → [product table, page 792](#)

²⁾ For additional withdrawal sleeve data → skf.com/go/17000-24-1

³⁾ Width before the sleeve is driven into the bearing bore

Principal dimensions				Mass	Designations	Sleeve ²⁾
d ₁	D	B	B ₂ ³⁾ ≈	Bearing + sleeve	Bearing ¹⁾	
mm				kg	–	
90	170	43	61	4,6	▶ 22219 EK	AHX 319
	200	45	61	7,4	21319 EK	AHX 319
	200	67	89	11	▶ 22319 EK	AHX 2319
95	165	52	68	5	▶ 23120 CCK/W33	AHX 3120
	180	46	63	5,4	▶ 22220 EK	AHX 320
	180	60,3	77	7,3	▶ 23220 CCK/W33	AHX 3220
	215	47	63	9,1	21320 EK	AHX 320
	215	73	94	14	▶ 22320 EK	AHX 2320
105	170	45	67	4,45	23022 CCK/W33	AHX 322
	180	56	72	6,35	▶ 23122 CCK/W33	AHX 3122
	180	69	91	7,7	24122 CCK30/W33	AH 24122
	200	53	72	7,5	▶ 22222 EK	AHX 3122
	200	69,8	86	10,5	▶ 23222 CCK/W33	AHX 3222 G
	240	80	102	19,5	▶ 22322 EK	AHX 2322 G
115	180	46	64	4,8	▶ 23024 CCK/W33	AHX 3024
	180	60	82	5,95	▶ 24024 CCK30/W33	AH 24024
	200	62	79	8,7	▶ 23124 CCK/W33	AHX 3124
	200	80	102	11	24124 CCK30/W33	AH 24124
	215	58	79	9,55	▶ 22224 EK	AHX 3124
	215	76	94	13	▶ 23224 CCK/W33	AHX 3224 G
	260	86	109	24	▶ 22324 CCK/W33	AHX 2324 G
125	200	52	71	6,75	▶ 23026 CCK/W33	AHX 3026
	200	69	93	8,65	▶ 24026 CCK30/W33	AH 24026
	210	64	82	9,6	▶ 23126 CCK/W33	AHX 3126
	210	80	104	11,5	24126 CCK30/W33	AH 24126
	230	64	82	11,5	▶ 22226 EK	AHX 3126
135	230	80	102	15,5	▶ 23226 CCK/W33	AHX 3226 G
	280	93	119	30,5	▶ 22326 CCK/W33	AHX 2326 G
	210	53	73	7,35	▶ 23028 CCK/W33	AHX 3028
	210	69	93	9,2	▶ 24028 CCK30/W33	AH 24028
	225	68	88	11,5	▶ 23128 CCK/W33	AHX 3128
	225	85	109	14,5	▶ 24128 CCK30/W33	AH 24128
	250	68	88	15	▶ 22228 CCK/W33	AHX 3128
	250	88	109	20,5	▶ 23228 CCK/W33	AHX 3228 G
	300	102	130	38	▶ 22328 CCK/W33	AHX 2328 G
	145	225	56	77	8,85	▶ 23030 CCK/W33
225		75	101	11,5	24030 CCK30/W33	AH 24030
250		80	101	17	▶ 23130 CCK/W33	AHX 3130 G
250		100	126	21	▶ 24130 CCK30/W33	AH 24130
270		73	101	19	▶ 22230 CCK/W33	AHX 3130 G
270		96	119	26	▶ 23230 CCK/W33	AHX 3230 G
320		108	140	45,5	▶ 22330 CCK/W33	AHX 2330 G

SKF Explorer bearing

▶ Popular item

¹⁾ For additional bearing data → [product table, page 792](#)

²⁾ For additional withdrawal sleeve data → skf.com/go/17000-24-1

³⁾ Width before the sleeve is driven into the bearing bore



9.3 Spherical roller bearings on a withdrawal sleeve

d_1 150 – 300 mm

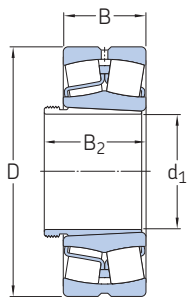

Bearing on an
AH sleeve

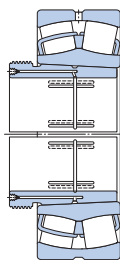

Bearing on an
AOH sleeve

Principal dimensions				Mass	Designations	Sleeve ²⁾	
d_1	D	B	$B_2^{3)}$	Bearing + sleeve	Bearing ¹⁾		
mm				kg	–		
150	240	60	82	11,5	▶ 23032 CCK/W33	AH 3032	
	240	80	106	15	▶ 24032 CCK30/W33	AH 24032	
	270	86	108	23	▶ 23132 CCK/W33	AH 3132 G	
	270	109	135	28,5	▶ 24132 CCK30/W33	AH 24132	
	290	80	108	25	▶ 22232 CCK/W33	AH 3132 G	
	290	104	130	34,5	▶ 23232 CCK/W33	AH 3232 G	
	340	114	146	56	22332 CCK/W33	AH 2332 G	
	160	260	67	90	15	▶ 23034 CCK/W33	AH 3034
		260	90	117	20	▶ 24034 CCK30/W33	AH 24034
		280	88	109	25	▶ 23134 CCK/W33	AH 3134 G
280		109	136	30	▶ 24134 CCK30/W33	AH 24134	
310		86	109	31	▶ 22234 CCK/W33	AH 3134 G	
310		110	140	41	▶ 23234 CCK/W33	AH 3234 G	
360		120	152	65	22334 CCK/W33	AH 2334 G	
170		280	74	98	19,5	▶ 23036 CCK/W33	AH 3036
		280	100	127	25,5	24036 CCK30/W33	AH 24036
		300	96	122	32	▶ 23136 CCK/W33	AH 3136 G
	300	118	145	37	24136 CCK30/W33	AH 24136	
	320	86	110	32,5	22236 CCK/W33	AH 2236 G	
	320	112	146	43,5	▶ 23236 CCK/W33	AH 3236 G	
	380	126	160	76	▶ 22336 CCK/W33	AH 2336 G	
	180	290	75	102	21	▶ 23038 CCK/W33	AH 3038 G
		290	100	131	27,5	24038 CCK30/W33	AH 24038
		320	104	131	38,5	▶ 23138 CCK/W33	AH 3138 G
320		128	159	46,5	24138 CCK30/W33	AH 24138	
340		92	117	39,5	22238 CCK/W33	AH 2238 G	
340		120	152	52,5	▶ 23238 CCK/W33	AH 3238 G	
400		132	167	87,5	▶ 22338 CCK/W33	AH 2338 G	

SKF Explorer bearing

▶ Popular item

¹⁾ For additional bearing data → [product table, page 792](#)

²⁾ For additional withdrawal sleeve data → skf.com/go/17000-24-1

³⁾ Width before the sleeve is driven into the bearing bore

Principal dimensions				Mass	Designations	Sleeve ²⁾	
d ₁	D	B	B ₂ ³⁾ ≈	Bearing + sleeve	Bearing ¹⁾		
mm				kg	–		
190	310	82	108	26,5	▶ 23040 CCK/W33	AH 3040 G	
	310	109	140	34,5	▶ 24040 CCK30/W33	AH 24040	
	340	112	140	48,5	▶ 23140 CCK/W33	AH 3140	
	340	140	171	57,5	▶ 24140 CCK30/W33	AH 24140	
	360	128	160	63	▶ 23240 CCK/W33	AH 3240	
	420	138	177	100	▶ 22340 CCK/W33	AH 2340	
	200	340	90	117	36,5	▶ 23044 CCK/W33	AOH 3044 G
		340	118	152	47,5	▶ 24044 CCK30/W33	AOH 24044
370		120	151	61,5	▶ 23144 CCK/W33	AOH 3144	
370		150	184	76	▶ 24144 CCK30/W33	AOH 24144	
400		108	136	68	▶ 22244 CCK/W33	AOH 2244	
400		144	189	93	▶ 23244 CCK/W33	AOH 2344	
460		145	189	130	▶ 22344 CCK/W33	AOH 2344	
220		360	92	123	40,5	▶ 23048 CCK/W33	AOH 3048
	360	118	153	50,5	▶ 24048 CCK30/W33	AOH 24048	
	400	128	161	76,5	▶ 23148 CCK/W33	AOH 3148	
	400	160	195	91,5	▶ 24148 CCK30/W33	AOH 24148	
	440	160	197	120	▶ 23248 CCK/W33	AOH 2348	
	500	155	197	165	▶ 22348 CCK/W33	AOH 2348	
	240	400	104	135	56,5	▶ 23052 CCK/W33	AOH 3052
		400	140	178	75	▶ 24052 CCK30/W33	AOH 24052 G
440		144	179	105	▶ 23152 CCK/W33	AOH 3152 G	
440		180	218	120	▶ 24152 CCK30/W33	AOH 24152	
480		130	161	120	▶ 22252 CCK/W33	AOH 2252 G	
480		174	213	155	▶ 23252 CCK/W33	AOH 2352 G	
540		165	213	205	▶ 22352 CCK/W33	AOH 2352 G	
260		420	106	139	62	▶ 23056 CCK/W33	AOH 3056
	420	140	179	79	▶ 24056 CCK30/W33	AOH 24056 G	
	460	146	183	110	▶ 23156 CCK/W33	AOH 3156 G	
	460	180	219	130	▶ 24156 CCK30/W33	AOH 24156	
	500	130	163	125	▶ 22256 CCK/W33	AOH 2256 G	
	500	176	220	160	▶ 23256 CCK/W33	AOH 2356 G	
	580	175	220	245	▶ 22356 CCK/W33	AOH 2356 G	
	280	460	118	153	82,5	▶ 23060 CCK/W33	AOH 3060
460		160	202	110	▶ 24060 CCK30/W33	AOH 24060 G	
500		160	200	140	▶ 23160 CCK/W33	AOH 3160 G	
500		200	242	180	▶ 24160 CCK30/W33	AOH 24160	
540		140	178	155	▶ 22260 CCK/W33	AOH 2260 G	
540		192	236	200	▶ 23260 CCK/W33	AOH 3260 G	
300		480	121	157	89	▶ 23064 CCK/W33	AOH 3064 G
		480	160	202	115	▶ 24064 CCK30/W33	AOH 24064 G
	540	176	217	175	▶ 23164 CCK/W33	AOH 3164 G	
	540	218	260	225	▶ 24164 CCK30/W33	AOH 24164	
	580	150	190	185	▶ 22264 CCK/W33	AOH 2264 G	
	580	208	254	250	▶ 23264 CCK/W33	AOH 3264 G	

SKF Explorer bearing

▶ Popular item

¹⁾ For additional bearing data → [product table, page 792](#)

²⁾ For additional withdrawal sleeve data → [skf.com/go/17000-24-1](#)

³⁾ Width before the sleeve is driven into the bearing bore



9.3 Spherical roller bearings on a withdrawal sleeve

d_1 320 – 670 mm

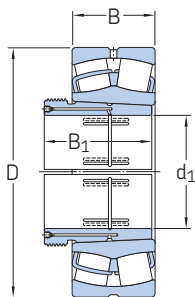

Principal dimensions				Mass	Designations	Sleeve ²⁾
d_1	D	B	$B_2^{3)}$	Bearing + sleeve	Bearing ¹⁾	
mm			≈	kg	–	
320	520	133	171	120	▶ 23068 CCK/W33	AOH 3068 G
	520	180	225	160	▶ 24068 CCK30/W33	AOH 24068
	580	190	234	225	▶ 23168 CCK/W33	AOH 3168 G
	580	243	288	295	24168 ECCK30J/W33	AOH 24168
	620	224	273	315	23268 CAK/W33	AOH 3268 G
	620	224	273	315		
340	540	134	176	125	23072 CCK/W33	AOH 3072 G
	540	180	226	165	24072 CCK30/W33	AOH 24072
	600	192	238	235	23172 CCK/W33	AOH 3172 G
	600	243	289	295	24172 ECCK30J/W33	AOH 24172
	650	170	238	275	22272 CAK/W33	AOH 3172 G
	650	232	283	345	23272 CAK/W33	AOH 3272 G
360	560	135	180	135	23076 CCK/W33	AOH 3076 G
	560	180	228	170	24076 CCK30/W33	AOH 24076
	620	194	242	250	▶ 23176 CAK/W33	AOH 3176 G
	620	243	291	325	24176 ECAK30/W33	AOH 24176
	680	240	294	390	23276 CAK/W33	AOH 3276 G
	680	240	294	390		
380	600	148	193	165	23080 CCK/W33	AOH 3080 G
	600	200	248	220	24080 ECCK30J/W33	AOH 24080
	650	200	250	290	23180 CAK/W33	AOH 3180 G
	650	250	298	365	24180 ECAK30/W33	AOH 24180
	720	256	312	470	23280 CAK/W33	AOH 3280 G
	820	243	312	675	22380 CAK/W33	AOH 3280 G
400	620	150	196	175	23084 CAK/W33	AOH 3084 G
	620	200	252	230	24084 ECAK30/W33	AOH 24084
	700	224	276	375	23184 CKJ/W33	AOH 3184 G
	700	280	332	470	24184 ECAK30/W33	AOH 24184
	760	272	331	550	23284 CAK/W33	AOH 3284 G
	760	272	331	550		
420	650	157	205	200	23088 CAK/W33	AOHX 3088 G
	650	212	264	275	24088 ECAK30/W33	AOH 24088
	720	226	281	380	23188 CAK/W33	AOHX 3188 G
	720	280	332	490	24188 ECAK30/W33	AOH 24188
	790	280	341	620	23288 CAK/W33	AOHX 3288 G
	790	280	341	620		

SKF Explorer bearing

▶ Popular item

¹⁾ For additional bearing data → [product table, page 792](#)

²⁾ For additional withdrawal sleeve data → skf.com/go/17000-24-1

³⁾ Width before the sleeve is driven into the bearing bore

Principal dimensions				Mass	Designations	Sleeve ²⁾	
d ₁	D	B	B ₂ ³⁾ ≈	Bearing + sleeve	Bearing ¹⁾		
mm				kg	–		
440	680	163	213	225	23092 CAK/W33	AOHX 3092 G	
	680	218	273	300	24092 ECAK30/W33	AOH 24092	
	760	240	296	465	23192 CAK/W33	AOHX 3192 G	
	760	300	355	590	24192 ECAK30/W33	AOH 24192	
	830	296	360	725	23292 CAK/W33	AOHX 3292 G	
	460	700	165	217	235	23096 CAK/W33	AOHX 3096 G
700		218	273	310	24096 ECAK30/W33	AOH 24096	
790		248	307	515	23196 CAK/W33	AOHX 3196 G	
790		308	363	635	24196 ECAK30/W33	AOH 24196	
870		310	376	860	23296 CAK/W33	AOHX 3296 G	
480		720	167	221	250	230/500 CAK/W33	AOHX 30/500 G
	720	218	276	325	240/500 ECAK30/W33	AOH 240/500	
	830	264	325	610	231/500 CAK/W33	AOHX 31/500 G	
	830	325	383	735	241/500 ECAK30/W33	AOH 241/500	
	920	336	405	1 020	232/500 CAK/W33	AOHX 32/500 G	
	500	780	185	242	365	230/530 CAK/W33	AOH 30/530
780		250	309	455	240/530 ECAK30/W33	AOH 240/530 G	
870		272	337	720	231/530 CAK/W33	AOH 31/530	
870		335	394	885	241/530 ECAK30/W33	AOH 241/530 G	
980		355	424	1 290	232/530 CAK/W33	AOH 32/530 G	
530		820	195	252	430	230/560 CAK/W33	AOHX 30/560
	820	258	320	515	240/560 ECAK30/W33	AOH 240/560 G	
	920	280	347	850	231/560 CAK/W33	AOH 31/560	
	920	355	417	1 060	241/560 ECK30J/W33	AOH 241/560 G	
	1 030	365	434	1 500	232/560 CAK/W33	AOHX 32/560	
	570	870	200	259	480	230/600 CAK/W33	AOHX 30/600
870		272	336	600	240/600 ECAK30/W33	AOHX 240/600	
980		300	369	1 010	231/600 CAK/W33	AOHX 31/600	
980		375	439	1 290	241/600 ECAK30/W33	AOHX 241/600	
1 090		388	459	1 760	232/600 CAK/W33	AOHX 32/600 G	
600		920	212	272	575	230/630 CAK/W33	AOH 30/630
	920	290	356	730	240/630 ECK30J/W33	AOH 240/630 G	
	1 030	315	389	1 190	231/630 CAK/W33	AOH 31/630	
	1 030	400	466	1 500	241/630 ECAK30/W33	AOH 241/630 G	
	630	980	230	294	720	230/670 CAK/W33	AOH 30/670
		980	308	374	900	240/670 ECAK30/W33	AOH 240/670 G
1 090		336	409	1 430	231/670 CAK/W33	AOHX 31/670	
1 090		412	478	1 730	241/670 ECAK30/W33	AOH 241/670	
1 220		438	514	2 500	232/670 CAK/W33	AOH 32/670 G	
670		1 030	236	302	800	230/710 CAK/W33	AOHX 30/710
	1 030	315	386	1 010	240/710 ECAK30/W33	AOH 240/710 G	
	1 150	345	421	1 650	231/710 CAK/W33	AOHX 31/710	
	1 150	438	509	2 040	241/710 ECAK30/W33	AOH 241/710	
	1 280	450	531	2 810	232/710 CAK/W33	AOH 32/710 G	

SKF Explorer bearing

¹⁾ For additional bearing data → [product table, page 792](#)

²⁾ For additional withdrawal sleeve data → [skf.com/go/17000-24-1](#)

³⁾ Width before the sleeve is driven into the bearing bore



9.3 Spherical roller bearings on a withdrawal sleeve

d_1 710 – 1 000 mm

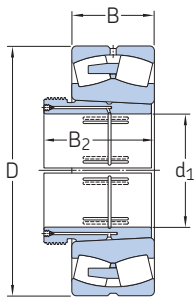

Principal dimensions				Mass	Designations	Sleeve ²⁾
d_1	D	B	$B_2^{3)}$	Bearing + sleeve	Bearing ¹⁾	
mm				kg	–	
710	1 090	250	316	950	230/750 CAK/W33	A0H 30/750
	1 090	335	408	1 200	240/750 ECAK30/W33	A0H 240/750 G
	1 220	365	441	1 930	231/750 CAK/W33	A0H 31/750
	1 220	475	548	2 280	241/750 ECAK30/W33	A0H 241/750 G
750	1 150	258	326	1 100	230/800 CAK/W33	A0H 30/800
	1 150	345	423	1 380	240/800 ECAK30/W33	A0H 240/800 G
	1 280	375	456	2 200	231/800 CAK/W33	A0H 31/800
	1 280	475	553	2 540	241/800 ECAK30/W33	A0H 241/800 G
800	1 220	272	343	1 250	230/850 CAK/W33	A0H 30/850
	1 220	365	445	1 670	240/850 ECAK30/W33	A0H 240/850 G
	1 360	500	600	3 050	241/850 ECAK30F/W33	A0H 241/850
850	1 280	280	355	1 450	230/900 CAK/W33	A0H 30/900
	1 280	375	475	1 850	240/900 ECAK30/W33	A0H 240/900
	1 420	515	620	3 700	241/900 ECAK30F/W33	A0H 241/900
900	1 360	300	375	1 720	230/950 CAK/W33	A0H 30/950
	1 360	412	512	2 300	240/950 CAK30F/W33	A0H 240/950
	1 500	545	650	3 950	241/950 ECAK30F/W33	A0H 241/950
950	1 420	412	519	2 500	240/1000 CAK30F/W33	A0H 240/1000
	1 580	462	547	3 950	231/1000 CAKF/W33	A0H 31/1000
	1 580	580	695	4 800	241/1000 ECAK30F/W33	A0H 241/1000
1 000	1 500	438	548	2 950	240/1060 CAK30F/W33	A0H 240/1060



SKF Explorer bearing

¹⁾ For additional bearing data → [product table, page 792](#)

²⁾ For additional withdrawal sleeve data → [skf.com/go/17000-24-1](#)

³⁾ Width before the sleeve is driven into the bearing bore

