



BEARINGS

Tapered roller bearings



Tapered roller bearings

Tapered roller bearings have the rolling elements under the form of frustra of cones. They roll on tapered surfaces which, if extended, converge towards a single point on the bearing axis.

The rollers are guided tangentially by the cage and axially by the big rib of the outer ring, on which they have point contact. As between rollers and raceways there is

linear contact, tapered roller bearings can take heavy radial loads. They can also take heavy axial or combined loads, depending on the contact angle caused by the tapered rolling elements. The contact angle is the angle of the outer raceway generatrix.

Tapered roller bearings can be manufactured in the versions : single, double and four row rollers.

Basic types and constructive versions:

- single row

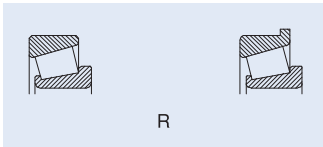

- paired

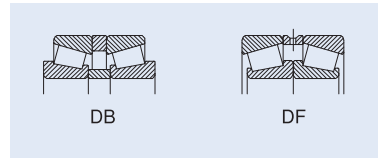

- double row

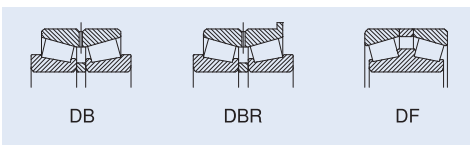

Suffixes

- A** - increased basic load
- A...** - axial clearance of bearing set
- B** - enlarged contact angle
- DB** - set of two bearings mounted in back-to-back arrangement (O)
- DF** - set of two bearings mounted in face-to-face arrangement (X)
- DF** - bearings with double row of rollers in face-to-face arrangement (X)
- F** - machined cage of hardened steel or special cast iron
- F2** - constructive modifications
- F32** - bearings with double row rollers in face-to-face arrangement, without distance ring between the outer rings

- J** - pressed cage of not hardened steel sheet
- K** - tapered bore 1:12
- M** - machined brass cage
- P6X** - tolerance class with smaller values than normal
- P5** - tolerance class with smaller values than P6X
- P4** - tolerance class with smaller values than P5
- P2** - tolerance class with smaller values than P4
- R** - rib on the outer ring
- S0** - operating temperature up to +150°C
- S1** - operating temperature up to +200°C
- T...** - bearing set width
- TN** - polyamide cage
- W6** - keygroove on the bore
- W7** - locating hole on the outer ring

- W28** - helical groove on bore surface
- W67** - locating groove on the inner ring face

- W69** - keygroove on the bore and locating ring on the inner ring face
- X** - modified main dimensions according to ISO

Single row tapered roller bearings

Single row tapered roller bearings are of separable design, i.e. the outer ring and the inner ring with rollers and cage assembly can be separately mounted. These two assemblies are interchangeable.

Tapered roller bearings can be manufactured both in standardized constructive versions with dimensions series 320, 302, 322, 303, 323, 313 and with non-standardized dimensions, mm or inch.

Tapered roller bearings can carry only single direction axial loads. Under pure radial loads, an axial force occurs which is supposed to distance the bearing rings in axial direction. Therefore, tapered roller bearings are generally pair mounted on both ends of the shaft, in "X" or "O" arrangements, so that the shaft will be axially located in both directions (table 4). Thus, the optimum clearance in these two bearings can be adjusted.

Single row tapered roller bearings can also be manufactured with rib on the outer ring. This design is to be used when the housing cannot be manufactured with shoulder, but only with a passed through bore. In this case, axial location can be provided by the bearing ring.

Paired single row tapered roller bearings

If tapered roller bearings are pair mounted in "X" or "O" arrangements, the load carrying capacity increases and loads can be taken in both directions in the same bearing.

These bearing sets have guaranteed clearance after mounting since the distance rings are mounted between the bearing rings.

For certain applications, paired bearings can be delivered with small clearance or lightly preloaded.

Double row tapered roller bearings

Double row tapered roller bearings are used where load carrying capacity should be greater, loads should be taken in both directions and axial space is smaller than in case of a set of two single row tapered roller bearings.

Double row tapered roller bearings can have the rollers in face- to-face arrangement, double inner ring and two outer rings respectively or the rollers in back-to-back arrangement, i.e. double outer ring and two inner rings.

The first design provides greater stiffness, can take tilting moments and shaft expansions can be compensated.

The bearings of the second design can be manufactured with tapered bore so that they can be frequently mounted /dismounted.

Double row tapered roller bearings can have or not

distance rings with lubrication holes, mounted between the simple rings.

In case of bearings with distance rings, the bearing clearance or preload are pre-adjusted; in case of those without distance rings, bearing clearance and preload can and should be adjusted while mounting.

Double row tapered roller bearings with rollers in back-to-back arrangement can also be manufactured in the following two versions:

- with rib on the outer ring; the housing has no shoulder and the bearing is axially located by the rib
- with two seals; this design is used in motor vehicles construction. The bearings are delivered filled with grease and relubrication is not needed.

Dimensions

Tapered roller bearings are manufactured with the following dimensions:

- metric dimensions (mm), according to ISO 355;
- inch dimensions

Misalignment

As between rollers and raceway there is a linear contact, tapered roller bearings have low capacity to compensate for errors of alignment between shaft and housing.

Permissible values of misalignment between shaft and housing are given in table 1, depending on bearing size and load magnitude.

Permissible misalignment

Table 1

Bearing series	Load magnitude	Permissible t misalignmen
329, 320, 302, 322, 303, 313	$F_r/C_{0r} < 0,1$ $F_r/C_{0r} > 0,1$	2' 4'
323, 34	$F_r/C_{0r} < 0,1$ $F_r/C_{0r} > 0,1$	1'30" 3'
35, 36 seturi DB, DF	$F_r/C_{0r} < 0,1$ $F_r/C_{0r} > 0,1$	1' 2'

Tolerances

Tapered roller bearings are generally manufactured to the normal tolerance class ISO and AFBMA, respectively (for bearings with inch dimensions).

For certain applications (e.g. bearings for machine-tools), they can be also manufactured to tolerance classes P5 and P6X or 3 AFBMA.

At request, they can be manufactured to tolerance class P4.

Single row tapered roller bearings have the outer rings interchangeable with the inner ring - rollers - cage assembly (if they have the same mark) and also with bearings produced by other companies, according to ISO and

AFBMA respectively.

The parts of the two and four row tapered roller bearings are non-interchangeable.

The tolerances for bearings overall dimensions are given in tables on page 24 for tapered roller bearings, both with metric and inch dimensions. Tolerances for mounting chamfer are given in tables on page 41.

Radial and axial clearance

In case of tapered roller bearings, clearance should be in radial direction, but it is measured and adjusted in axial direction. As tapered roller bearings are dismountable, their clearance is not guaranteed by design and it is adjusted while mounting. Thus, optimum clearance can be obtained for that application.

In case of double and four row tapered roller bearings with distance rings between bearing rings, the clearance is guaranteed and its values are given in table 2. The bearing parts are numbered for each bearing so that the prescribed clearance on each row should be observed while mounting.

In case of bearings without distance rings, clearance is adjusted as for single row tapered roller bearings: for DB design - by the inner rings and for DF design by the outer rings. The above specifications are also available for bearings matched in sets.

The values of the axial clearance can be calculated using the equation:

$$\text{axial clearance} = \frac{\text{radial clearance}}{2 \operatorname{tg} \alpha}$$

where α is the contact angle.

In case of certain applications where clearance between shaft and housing should be avoided, tapered roller bearings can also be pre-tightened. This can be adjusted while mounting or is pre-adjusted by distance rings, in case of two or four row tapered roller bearings.

Contact angle

Contact angle of tapered roller bearings is the angle of the outer ring raceway generatrix. In case of standardized single row tapered roller bearings, this angle can be found in the standard of dimensions (ISO 355 and national standard STAS 3920 respectively). Bearings series 329, 302, 322, 303 and 323 have a contact angle between 10° and 17° and those of series 313 have a contact angle of 28° 48' 39", so that they can take heavier axial loads. Non-standardized single row tapered roller bearings and also all double and four-row tapered roller bearings have the contact angle between 9° and 30°.

Cages

Small and medium sized tapered roller bearings are generally fitted with pressed sheet cages. Large sized bearings are generally fitted with machined steel or brass cages, with welded pins. In some cases, median or large sized bearings can also be fitted with machined steel or brass cages. In all cases, the cage is guided on rollers.

Radial clearance of double tapered roller bearings

Table 2

Bore diameter d		Radial clearance symbol				Normal		C3		C4		C5	
over	up to	C1		C2									
		min.	max.	min.	max.	min.	max.	min.	max.	min.	max.	min.	max.
mm		μm											
50	65	0	15	15	30	30	50	50	70	70	90	90	120
65	80	0	20	20	40	40	60	60	80	80	110	110	150
80	100	0	20	20	45	45	70	70	100	100	130	130	170
100	120	0	25	25	50	50	80	80	110	110	150	150	200
120	140	0	30	30	60	60	90	90	120	120	170	170	230
140	160	0	30	30	65	65	100	100	140	140	190	190	260
160	180	0	35	35	70	70	110	110	150	150	210	210	280
180	200	0	40	40	80	80	120	120	170	170	230	230	310
200	225	0	40	40	90	90	140	140	190	190	260	260	340
225	250	0	50	50	100	100	150	150	210	210	290	290	380
250	280	0	50	50	110	110	170	170	230	230	320	320	420
280	315	0	60	60	120	120	180	180	250	250	350	350	460
315	355	0	70	70	140	140	210	210	280	280	390	390	510
355	400	0	70	70	150	150	230	230	310	310	440	440	580
400	450	0	80	80	170	170	260	260	350	350	490	490	650
450	500	0	90	90	190	190	290	290	390	390	540	540	720
500	560	0	100	100	210	210	320	320	430	430	590	590	790
560	630	0	110	110	230	230	350	350	480	480	660	660	880
630	710	0	130	130	260	260	400	400	540	540	740	740	910
710	800	0	140	140	290	290	450	450	610	610	830	830	1 100
800	900	0	160	160	330	330	500	500	670	670	920	920	1 240

For small and medium sized bearings, glass fibre reinforced polyamide 6.6 cages can be successfully used if the operating temperature doesn't exceed +120°C. They have low weight, are noiseless in operation and have low coefficient of friction.

Designs and some technical data are given in table 3.

Equivalent dynamic radial load

Equivalent dynamic radial load can be calculated using the following equations:

- for single row tapered roller bearings:

$$P_r = F_r, \text{ kN, when } F_a/F_r \leq e$$

$$P_r = 0,4 F_r + Y F_a, \text{ kN, when } F_a/F_r > e$$

- for paired bearings and double or four-row tapered roller bearings:

$$P_r = F_r + Y_1 F_a, \text{ kN, when } F_a/F_r \leq e$$

$$P_r = 0,67 F_r + Y_2 F_a, \text{ kN, when } F_a/F_r > e$$

For single row tapered roller bearings, the F_a values can be calculated using the equations in table 4. These equations are available when bearings are mounted so that axial clearance is in fact zero without preloading. F_{rA} and F_{rB} should always be considered as being positive, even if they act in the opposite direction to that in the figure.

In case of paired bearings and of double or four row tapered roller bearings, F_a and F_r are the loads acting upon the paired bearings or single bearings.

The values of e , Y , Y_1 and Y_2 are given in bearing tables.

Equivalent static radial load

Equivalent static radial load can be calculated using the equations:

- for single row tapered roller bearings:

$$P_{0r} = F_r, \text{ kN, when } F_a/F_r \leq 1/2 Y_0$$

$$P_{0r} = 0,5 F_r + Y_0 F_a, \text{ kN, when } F_a/F_r > 1/2 Y_0$$

- for paired double or four row tapered roller bearings

$$P_{0r} = F_r + Y_0 F_a, \text{ kN}$$





F_a is calculated as in case of equivalent dynamic radial load. The values of Y_0 are given in bearing tables.

Abutment dimensions

The mounting dimensions of tapered roller bearings are given in the bearings tables, for single row tapered roller bearings. These dimensions are also available for bearings with ribs and for standardized paired bearings. For the other types of tapered roller bearings, the mounting dimensions should be adapted depending on the cross section size and mounting chamfer.

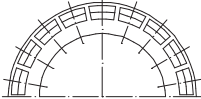
Cage designs and some technical data

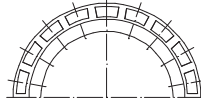
Table 3

Cage	Design Bearing	Cage	Application	Max. value $D_m n$	oil	grease
Pressed sheet cage				- General application - Small and medium sized bearings $d \leq 250 \text{ mm}$	350×10^3	245×10^3
Machined brass cage M				- General application - Median and large sized bearings $d > 150 \text{ mm}$	450×10^3	315×10^3

Calculating relations for axial loadings F_a

Table 4

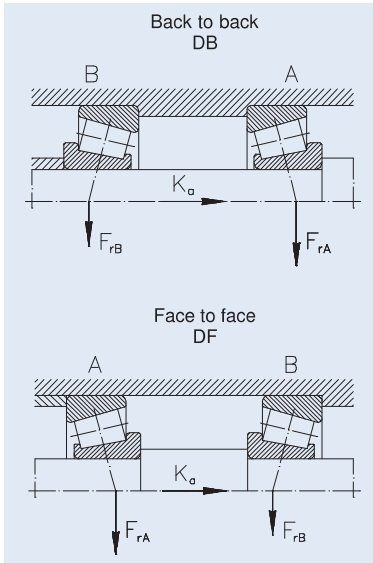

Loading versions Axial load

$$1a) \quad \frac{F_{rA}}{Y_A} \geq \frac{F_{rB}}{Y_B} \quad F_{aA} = \frac{0,5 F_{rA}}{Y_A}$$

$$K_a \geq 0 \quad F_{aB} = F_{aA} + K_a$$

$$1b) \quad \frac{F_{rA}}{Y_A} < \frac{F_{rB}}{Y_B} \quad F_{aA} = \frac{0,5 F_{rA}}{Y_A}$$

$$K_a \geq 0,5 \left(\frac{F_{rB}}{Y_B} - \frac{F_{rA}}{Y_A} \right) \quad F_{aB} = F_{aA} + K_a$$

$$1c) \quad \frac{F_{rA}}{Y_A} < \frac{F_{rB}}{Y_B} \quad F_{aA} = F_{aB} - K_a$$

$$K_a < 0,5 \left(\frac{F_{rB}}{Y_B} - \frac{F_{rA}}{Y_A} \right) \quad F_{aB} = \frac{0,5 F_{rB}}{Y_B}$$

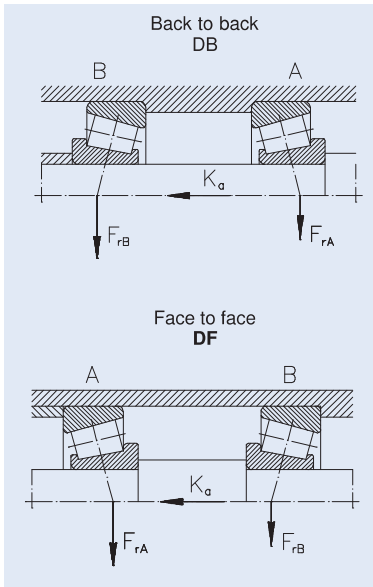

$$2a) \quad \frac{F_{rA}}{Y_A} \leq \frac{F_{rB}}{Y_B} \quad F_{aA} = F_{aB} + K_a$$

$$K_a \geq 0 \quad F_{aB} = \frac{0,5 F_{rB}}{Y_B}$$

$$2b) \quad \frac{F_{rA}}{Y_A} > \frac{F_{rB}}{Y_B} \quad F_{aA} = F_{aB} + K_a$$

$$K_a \geq 0,5 \left(\frac{F_{rA}}{Y_A} - \frac{F_{rB}}{Y_B} \right) \quad F_{aB} = \frac{0,5 F_{rB}}{Y_B}$$

$$2c) \quad \frac{F_{rA}}{Y_A} > \frac{F_{rB}}{Y_B} \quad F_{aA} = \frac{0,5 F_{rA}}{Y_A}$$

$$K_a < 0,5 \left(\frac{F_{rA}}{Y_A} - \frac{F_{rB}}{Y_B} \right) \quad F_{aB} = F_{aA} - K_a$$

Tapered roller bearings, single row

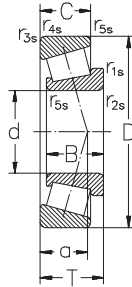

Dimensions					Designation		ISO series	Basic radial load. Factors							
d	D	B	C	T	r _{1s} , r _{2s} min. min.	r _{3s} , r _{4s} min. min.	r _{5s}	a	dyn. C _r	e	Y	stat. C _{0r}	Y ₀		
mm									—	kN	—	kN	—		
15	42	13	11	14,25	1	1	0,3	9	30302 A	2FB	21,5	0,28	2,1	19,8	1,1
17	40	12	11	13,25	1	1	0,3	10	30203 A	2DB	18,3	0,35	1,7	190,9	
	47	14	12	15,25	1	1	0,3	10	30303 A	2FB	26	0,28	2,1	24,5	1,1
	47	19	16	20,25	1	1	0,3	12	32303 A	2FD	34	0,28	2,1	35,5	1,1
20	42	15	12	15	0,6	0,6	0,3	10	32004 XA	3CC	26	0,37	1,6	28,5	0,9
	47	14	12	15,25	1	1	0,3	11	30204 A	2DB	25,8	0,35	1,7	26,4	0,9
	52	15	13	16,25	1,5	1,5	0,6	11	30304 A	2FB	32	0,3	2	321,1	
	52	21	18	22,25	1,5	1,5	0,6	14	32304 A	2FD	42,5	0,3	2	471,1	
25	47	15	11,5	15	0,6	0,6	0,3	11	32005 XA	4CC	26	0,43	1,4	33,5	0,8
	52	15	13	16,25	1	1	0,3	12	30205 A	3CC	30,1	0,37	1,6	32,9	0,9
	52	18	15	19,25	1	1	0,3	16	32205 A	2CD	31	0,33	1,8	37,1	
	62	17	15	18,25	1,5	1,5	0,6	13	30305 A	2FB	43	0,3	2	431,1	
	62	17	13	18,25	1,5	1,5	0,6	20	31305 A	7FB	39	0,83	0,7	410,4	
	62	24	20	25,25	1,5	1,5	0,6	15	32305 A	2FD	58,3	0,3	2	60,3	1,1
30	55	17	13	17	1	1	0,3	13	32006 XA	4CC	34	0,43	1,4	45,5	0,8
	62	16	14	17,25	1	1	0,3	14	30206 A	3DB	40,5	0,37	1,6	45,1	0,9
	62	20	17	21,25	1	1	0,3	15	32206 A	3DC	49	0,37	1,6	610,9	
	72	19	16	20,75	1,5	1,5	0,6	15	30306 A	2FB	52,9	0,31	1,9	51,8	1,1
	72	19	14	20,75	1,5	1,5	0,6	22	31306 A	7FB	46,5	0,83	0,7	49,5	0,4
	72	27	23	28,75	1,5	1,5	0,6	18	32306 A	2FD	75,8	0,31	1,9	82,7	1,1
35	62	18	14	18	1	1	0,3	15	32007 XA	4CC	35,9	0,46	1,3	52,4	0,7
	72	17	15	18,25	1,5	1,5	0,6	15	30207 A	3DB	50,5	0,37	1,6	54,7	0,9
	72	23	19	24,25	1,5	1,5	0,6	17	32207 A	3DC	66,2	0,37	1,6	77,5	0,9
	80	21	18	22,75	2	1,5	0,6	16	30307 A	2FB	71,2	0,31	1,9	72,5	1,1
	80	21	15	22,75	2	1,5	0,6	25	31307 A	7FB	58,1	0,83	0,7	640,4	
	80	31	25	32,75	2	1,5	0,6	20	32307 A	2FE	95,3	0,31	1,9	106	1,1
40	68	19	14,5	19	1	1	0,3	15	32008 XA	3CD	48,8	0,37	1,6	65,6	0,9
	80	18	16	19,75	1,5	1,5	0,6	16	30208 A	3DB	57,9	0,37	1,6	62,4	0,9
	80	23	19	24,75	1,5	1,5	0,6	19	32208 A	3DC	66,2	0,37	1,6	79,5	0,9
	90	23	20	25,25	2	1,5	0,6	19	30308 A	2FB	83,9	0,35	1,7	91,3	0,9
	90	23	17	25,25	2	1,5	0,6	28	31308 A	7FB	74,6	0,83	0,7	60,8	0,4
	90	33	27	35,25	2	1,5	0,6	23	32308 A	2FD	105	0,35	1,7	122	0,9
45	75	20	15,5	20	1	1	0,3	16	32009 XA	3CC	57	0,4	1,5	82,2	0,8
	85	19	16	20,75	1,5	1,5	0,6	18	30209 A	3DB	60,1	0,4	1,5	67,1	0,8
	85	23	19	24,75	1,5	1,5	0,6	20	32209 A	3DC	76,5	0,4	1,5	91,6	0,8
	100	25	22	27,25	2	1,5	0,6	21	30309 A	2FB	106	0,35	1,7	118	0,9
	100	25	18	27,25	2	1,5	0,6	31	31309 A	7FB	88,9	0,83	0,7	97,1	0,4
100	36	30	38,25	2	1,5	0,6	25	32309 A	2FD	133	0,35	1,7	159	0,9	
50	80	20	15,5	20	1	1	0,3	18	32010 XA	3CC	58,5	0,43	1,4	88,5	0,8

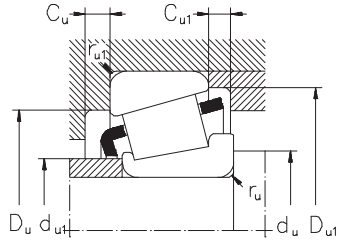

Speed limit		Weight	Mounting dimensions								
grease	oil		d_{u1} max.	d_u min.	D_u min.	max.	D_{u1} min.	C_u min.	C_{u1} min.	r_u max.	r_{u1} max.
min ⁻¹		kg	mm								
9 000	13 000	0,090	22	21	36	36	38	2	3	1	1
9 000	13 000	0,074	23	23	34	34	37	2	2	1	1
8 500	12 000	0,130	25	23	40	41	42	2	3	1	1
8 000	11 000	0,170	24	23	39	41	43	3	4	1	1
8 500	12 000	0,097	25	25	36	37	39	3	3	0,6	0,6
8 000	11 000	0,120	27	26	40	41	43	2	3	1	1
8 000	11 000	0,170	28	27	44	45	47	2	3	1,5	1,5
7 500	10 000	0,221	27	27	43	45	47	3	4	1,5	1,5
8 000	11 000	0,113	30	30	40	42	44	3	3,5	0,6	0,6
7 500	10 000	0,150	31	31	44	46	48	2	3	1	1
7 500	10 000	0,182	31	31	44	46	48	3	4	1	1
6 700	9 000	0,250	34	32	54	55	57	2	3	1,5	1,5
5 600	7 500	0,255	34	32	47	55	59	3	5	1,5	1,5
6 000	8 000	0,360	33	32	53	55	57	3	5	1,5	1,5
6 700	9 000	0,017	35	36	48	49	52	3	4	1	1
6 300	8 500	0,220	37	36	53	56	57	2	3	1	1
6 300	8 500	0,280	37	36	52	56	59	3	4	1	1
5 600	7 500	0,380	40	37	62	65	66	3	4,5	1,5	1,5
5 000	6 700	0,390	40	37	55	65	68	3	6,5	1,5	1,5
5 300	7 000	0,550	39	37	59	65	66	4	5,5	1,5	1,5
6 000	8 000	0,220	40	41	54	56	59	4	4	1	1
5 300	7 000	0,320	44	42	62	65	67	3	3	1,5	1,5
5 300	7 000	0,420	43	42	61	65	67	3	5,5	1,5	1,5
5 000	6 700	0,520	45	44	70	71	74	3	4,5	2	1,5
4 500	6 000	0,520	44	44	62	71	76	4	7,5	2	1,5
4 800	6 300	0,730	44	44	66	71	74	4	7,5	2	1,5
5 300	7 000	0,270	46	46	60	62	65	4	4,5	1	1
4 800	6 300	0,420	49	47	69	73	74	3	3,5	1,5	1,5
4 800	6 300	0,510	48	47	68	73	75	3	5,5	1,5	1,5
4 500	6 000	0,700	52	49	77	81	82	3	5	2	1,5
4 000	5 300	0,685	51	49	71	81	86	4	8	2	1,5
4 000	5 300	0,993	50	49	73	81	82	4	8	2	1,5
4 800	6 300	0,330	51	51	67	69	72	4	4,5	1	1
4 500	6 000	0,470	54	52	74	78	80	3	4,5	1,5	1,5
4 500	6 000	0,560	53	52	73	78	80	3	5,5	1,5	1,5
4 000	5 300	0,920	59	54	86	91	92	3	5	2	1,5
3 400	4 500	0,915	56	54	79	91	95	4	9	2	1,5
3 600	4 800	1,25	56	54	82	91	93	4	8	2	1,5
4 500	6 000	0,360	56	56	72	74	77	4	4,5	1	1

Tapered roller bearings, single row

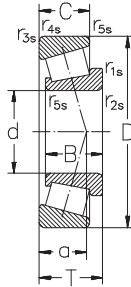

Dimensions					Designation		ISO series	Basic radial load. Factors							
d	D	B	C	T	r _{1s} , r _{2s} min. min.	r _{3s} , r _{4s} min. min.	r _{5s}	a	dyn. C _r	e	Y	stat. C _{0r}	Y ₀		
mm									kN	—		kN	—		
50	90	20	17	21,75	1,5	1,5	0,6	19	30210 A	3DB	69,7	0,43	1,4	81,3	0,8
	90	23	19	24,75	1,5	1,5	0,6	21	32210 A	3DC	79,1	0,43	1,4	95,8	0,8
	110	27	23	29,25	2,5	2	0,6	23	30310 A	2FB	120	0,35	1,7	133	0,9
	110	27	19	29,25	2,5	2	0,6	34	31310 A	7FB	102	0,83	0,7	112	0,4
	110	40	33	42,25	2,5	2	0,6	27	32310 A	2FD	160	0,35	1,7	194	0,9
55	90	23	17,5	23	1,5	1,5	0,6	20	32011 XA	3CC	77	0,4	1,5	117	0,8
	100	21	18	22,75	2	1,5	0,6	20	30211 A	3DB	83	0,4	1,5	95,2	0,8
	100	25	21	26,75	2	1,5	0,6	22	32211 A	3DC	96,2	0,4	1,5	115	0,8
	120	29	25	31,5	2,5	2	0,6	24	30311 A	2FB	146	0,35	1,7	166	0,9
	120	29	21	31,5	2,5	2	0,6	37	31311 A	7FB	118	0,83	0,7	133	0,4
	120	43	35	45,5	2,5	2	0,6	29	32311 A	2FD	191	0,35	1,7	235	0,9
	120	43	35	45,5	2,5	2	0,6	29	32311 A	2FD	191	0,35	1,7	235	0,9
60	95	23	17,5	23	1,5	1,5	0,6	21	32012 XA	4CC	78,5	0,43	1,4	119	0,8
	110	22	19	23,75	2	1,5	0,6	22	30212 A	3EB	91,6	0,4	1,5	105	0,8
	110	28	24	29,75	2	1,5	0,6	24	32212 A	3EC	122	0,4	1,5	152	0,8
	130	31	26	33,5	3	2,5	1	26	30312 A	2FB	164	0,35	1,7	187	0,9
	130	31	22	33,5	3	2,5	1	39	31312 A	7FB	140	0,83	0,7	158	0,4
	130	46	37	48,5	3	2,5	1	31	32312 A	2FD	229	0,35	1,7	288	0,9
65	100	23	17,5	23	1,5	1,5	0,6	22	32013 XA	4CC	80,6	0,46	1,3	123	0,7
	120	23	20	24,75	2	1,5	0,6	23	30213 A	3EB	111	0,4	1,5	129	0,8
	120	31	27	32,75	2	1,5	0,6	27	32213 A	3EC	149	0,4	1,5	189	0,8
	140	33	28	36	3	2,5	1	28	30313 A	2GB	191	0,35	1,7	220	0,9
	140	33	23	36	3	2,5	1	42	31313 A	7GB	164	0,83	0,7	189	0,4
	140	48	39	51	3	2,5	1	33	32313 A	2GO	256	0,35	1,7	322	0,9
	140	48	39	51	3	2,5	1	33	32313 A	2GO	256	0,35	1,7	322	0,9
70	110	25	19	25	1,5	1,5	0,6	23	32014 XA	4CC	95,6	0,43	1,4	143	0,8
	125	24	21	26,25	2	1,5	0,6	25	30214 A	3EB	119	0,43	1,4	143	0,8
	125	31	27	33,25	2	1,5	0,6	28	32214 A	3EC	157	0,43	1,4	204	0,8
	150	35	30	38	3	2,5	1	29	30314 A	2GB	224	0,35	1,7	264	0,9
	150	35	25	38	3	2,5	1	45	31314 A	7GB	185	0,83	0,7	215	0,4
	150	51	42	54	3	2,5	1	36	32314 A	2GD	297	0,35	1,7	381	0,9
75	115	25	19	25	1,5	1,5	0,6	25	32015 XA	4CC	97,3	0,46	1,3	149	0,7
	130	25	22	27,25	2	1,5	0,6	27	30215 A	4DB	134	0,43	1,4	166	0,8
	130	31	27	33,25	2	1,5	0,6	29	32215 A	4DC	157	0,43	1,4	205	0,8
	160	37	31	40	3	2,5	1	31	30315 A	2GB	246	0,35	1,7	289	0,9
	160	37	26	40	3	2,5	1	48	31315 A	7GB	213	0,83	0,7	251	0,4
	160	55	45	58	3	2,5	1	38	32315 A	2GD	350	0,35	1,7	460	0,9
80	125	29	22	29	1,5	1,5	0,6	27	32016 XA	3CC	130	0,43	1,4	198	0,8
	140	26	22	28,25	2,5	2	0,6	28	30216 A	3EB	145	0,43	1,4	177	0,8
	140	33	28	35,25	2,5	2	0,6	30	32216 A	3EC	180	0,43	1,4	232	0,8
	170	39	33	42,5	3	2,5	1	33	30316 A	2GB	277	0,35	1,7	329	0,9
	170	39	27	42,5	3	2,5	1	52	31316 A	7GB	222	0,83	0,7	275	0,4

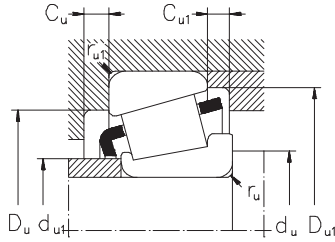

Speed limit		Weight	Mounting dimensions								
grease	oil		d_{u1} max.	d_u min.	D_u min.	max.	D_{u1} min.	C_u min.	C_{u1} min.	r_u max.	r_{u1} max.
min^{-1}	kg	mm									
4 300	5 600	0,530	58	57	79	83	85	3	4,5	1,5	1,5
4 300	5 600	0,600	58	57	78	83	85	3	5,5	1,5	1,5
3 600	4 800	1,19	65	60	95	100	102	4	6	2,5	2
3 200	4 300	1,16	62	60	87	100	104	4	10	2,5	2
3 200	4 300	1,83	62	60	90	100	102	5	9	2,5	2
4 000	5 300	0,540	63	62	81	83	86	4	5,5	1,5	1,5
3 800	5 000	0,690	64	64	88	91	94	4	4,5	1,5	1,5
3 800	5 000	0,820	63	64	87	91	95	4	5,5	1,5	1,5
3 200	4 300	1,53	71	65	104	110	111	4	6,5	2	2
2 800	3 800	1,49	68	65	94	110	113	4	10,5	2	2
3 000	4 000	2,21	68	65	99	110	111	5	10,5	2	2
3 800	5 000	0,580	67	67	85	88	91	4	5,5	1,5	1,5
3 400	4 500	0,860	70	69	96	101	103	4	4,5	2	1,5
3 400	4 500	1,10	69	69	95	101	104	4	5,5	2	1,5
3 000	4 000	1,90	77	72	112	118	120	5	7,5	3	2,5
2 600	3 600	1,83	73	72	103	118	123	5	11,5	3	2,5
2 600	3 600	2,80	74	72	107	118	120	6	11,5	3	2,5
3 400	4 500	0,620	72	72	90	93	97	4	5,5	1,5	1,5
3 000	4 000	1,10	77	74	106	111	113	4	4,5	2	1,5
3 000	4 000	1,48	76	74	104	111	115	4	5,5	2	1,5
2 600	3 600	2,30	83	77	122	128	130	5	8	3	2,5
2 200	3 200	2,25	79	77	111	128	132	5	13	3	2,5
2 400	3 400	3,49	80	77	117	128	130	6	12	3	2,5
3 200	4 300	0,830	78	77	98	103	105	5	6	1,5	1,5
3 000	4 000	1,22	81	79	110	116	118	4	5	2	1,5
2 800	3 800	1,56	80	79	108	116	119	4	6	2	1,5
2 400	3 400	3,00	89	82	130	138	140	5	8	3	2,5
2 000	3 000	2,82	84	82	118	138	141	5	13	3	2,5
2 200	3 200	4,10	86	82	125	138	140	6	12	3	2,5
3 000	4 000	0,880	83	82	103	108	110	5	6	1,5	1,5
2 800	3 800	1,33	86	84	115	121	124	4	5	2	1,5
2 600	3 600	2,62	85	84	115	121	124	4	6	2	1,5
2 600	3 600	3,40	95	87	139	148	149	5	9	3	2,5
1 900	2 800	3,50	91	87	127	148	151	6	14	3	2,5
2 000	3 000	5,00	91	87	133	148	149	7	13	3	2,5
2 600	3 600	1,24	89	87	112	117	120	6	7	1,5	1,5
2 400	3 400	1,59	91	90	124	130	132	4	6	2,5	2
2 400	3 400	2,00	90	90	122	130	134	5	7	2,5	2
2 000	3 000	4,00	102	92	148	158	159	5	9,5	3	2,5
1 900	2 800	4,07	97	92	134	158	159	6	15,5	3	2,5

Tapered roller bearings, single row

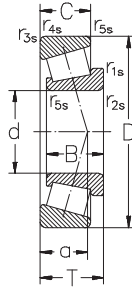

Dimensions						Designation				ISO series	Basic radial load. Factors				
d	D	B	C	T	r _{1s} , r _{2s} min. min.	r _{3s} , r _{4s} min. min.	r ₅	a	dyn. C _r	e	Y	stat. C _{0r}	Y ₀		
mm										—	kN	—	kN	—	
80	170	58	48	61,5	3	2,5	1	41	32316 A	2GD	383	0,35	1,7	503	0,9
85	130	29	22	29	1,5	1,5	0,6	28	32017 XA	4CC	136	0,44	1,4	213	0,8
	150	28	24	30,5	2,5	2	0,6	30	30217 A	3EB	167	0,43	1,4	206	0,8
	150	36	30	38,5	2,5	2	0,6	33	32217 A	3EC	213	0,43	1,4	283	0,8
	180	41	34	44,5	4	3	1	35	30317 A	2GB	298	0,35	1,7	354	0,9
	180	41	28	44,5	4	3	1	55	31317 A	7GB	245	0,83	0,7	298	0,4
	180	60	49	63,5	4	3	1	42	32317 A	2GD	400	0,35	1,7	555	0,9
90	140	32	24	32	2	1,5	0,6	30	32018 XA	3CC	159	0,43	1,4	246	0,8
	160	30	26	32,5	2,5	2	0,6	31	30218 A	3FB	190	0,43	1,4	238	0,8
	160	40	34	42,5	2,5	2	0,6	36	32218 A	3FC	251	0,43	1,4	340	0,8
	190	43	36	46,5	4	3	1	36	30318 A	2GB	328	0,35	1,7	394	0,9
	190	43	30	46,5	4	3	1	57	31318 A	7GB	270	0,83	0,7	330	0,4
	190	64	53	67,5	4	3	1	44	32318 A	2GD	461	0,35	1,7	612	0,9
95	145	32	24	32	2	1,5	0,6	31	32019 XA	4CC	163	0,44	1,4	257	0,8
	170	32	27	34,5	3	2,5	1	33	30219 A	2FB	210	0,43	1,4	264	0,8
	170	43	37	45,5	3	2,5	1	39	32219 A	3FC	281	0,43	1,4	390	0,8
	200	45	38	49,5	4	3	1	39	30319 A	2GB	350	0,35	1,7	449	0,9
	200	45	32	49,5	4	3	1	60	31319 A	7GB	300	0,83	0,7	365	0,4
	200	67	55	71,5	4	3	1	47	32319 A	2GD	500	0,35	1,7	670	0,9
100	150	32	24	32	2	1,5	0,6	32	32020 XA	4CC	171	0,46	1,3	277	0,7
	180	34	29	37	3	2,5	1	35	30220 A	3FB	238	0,43	1,4	303	0,8
	180	46	39	49	3	2,5	1	41	32220 A	3FC	320	0,43	1,4	444	0,8
	215	47	39	51,5	4	3	1	40	30320 A	2GB	404	0,35	1,7	492	0,9
	215	73	60	77,5	4	3	1	53	32320 A	2GD	578	0,35	1,7	780	0,9
105	160	35	26	35	2,5	2	0,6	34	32021 XA	4DC	204	0,44	1,4	334	0,8
	190	36	30	39	3	2,5	1	37	30221 A	3FB	270	0,43	1,4	350	0,8
	190	50	43	53	3	2,5	1	44	32221 A	3FC	358	0,43	1,4	510	0,8
	225	77	63	81,5	4	3	1	53	32321 A	2GD	405	0,35	1,7	815	0,9
110	170	38	29	38	2,5	2	0,6	36	32022 XA	4DC	235	0,43	1,4	382	0,8
	200	38	32	41	3	2,5	1	39	30222 A	3FB	304	0,43	1,4	396	0,8
	200	53	46	56	3	2,5	1	46	32222 A	3FC	406	0,43	1,4	580	0,8
	240	50	42	54,5	4	3	1	43	30322 A	2GB	479	0,35	1,7	588	0,9
	240	80	65	84,5	4	3	1	55	32322 A	2GD	699	0,35	1,7	956	0,9
120	180	38	29	38	2,5	2	0,6	39	32024 XA	4DC	238	0,46	1,3	397	0,7
	215	40	34	43,5	3	2,5	1	43	30224 A	4FB	340	0,43	1,4	459	0,8
	215	58	50	61,5	3	2,5	1	51	32224 A	4FD	446	0,43	1,4	653	0,8
	260	55	46	59,5	4	3	1	47	30324 A	2GB	568	0,35	1,7	712	0,9
	260	86	69	90,5	4	3	1	60	32324 A	2GD	799	0,35	1,7	1104	0,9
130	200	45	34	45	2,5	2	0,6	42	32026 XA	4EC	315	0,43	1,4	526	0,8
	230	40	34	43,75	4	3	1	45	30226 A	4FB	367	0,43	1,4	485	0,8
	230	64	54	67,75	4	3	1	56	32226 A	4FD	551	0,43	1,4	836	0,8

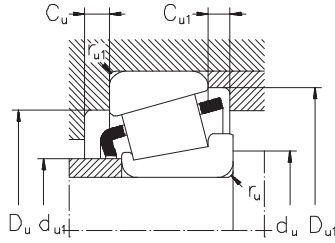

Speed limit		Weight	Mounting dimensions								
grease	oil		d_{u1} max.	d_u min.	D_u min.	max.	D_{u1} min.	C_u min.	C_{u1} min.	r_u max.	r_{u1} max.
min^{-1}	kg	mm									
1 900	2 800	5,90	98	92	142	158	159	7	13,5	3	2,5
2 400	3 400	1,30	94	92	117	122	125	6	7	1,5	1,5
2 200	3 200	2,00	97	95	132	140	141	5	6,5	2,5	2
2 200	3 200	2,50	96	95	130	140	142	5	8,5	2,5	2
1 900	2 800	4,70	107	99	156	166	167	6	10,5	4	3
1 800	2 600	5,08	103	99	143	166	169	6	16,5	4	3
1 800	2 600	6,85	103	99	150	166	167	8	14,5	4	3
2 200	3 200	1,70	100	99	125	131	134	6	8	2	1,5
2 200	3 000	2,49	103	100	140	150	150	5	6,5	2,5	2
2 000	3 000	3,30	102	100	138	150	152	5	8,5	2,5	2
1 700	2 400	5,50	113	104	165	176	176	6	10,5	4	3
1 700	2 400	5,92	109	104	151	176	179	6	16,5	4	3
1 700	2 400	8,21	108	104	157	176	177	8	14,5	4	3
2 200	3 200	1,80	105	104	130	136	140	6	8	2	1,5
1 900	2 800	2,96	110	107	149	158	159	5	7,5	3	2,5
1 900	2 800	4,00	108	107	145	158	161	5	8,5	3	2,5
1 800	2 600	6,70	118	109	172	186	184	6	11,5	4	3
1 700	2 400	6,95	114	109	157	186	187	6	17,5	4	3
1 700	2 400	11,0	115	109	166	186	186	8	16,5	4	3
2 000	3 000	1,85	109	109	134	141	144	6	8	2	1,5
1 900	2 800	3,54	116	112	157	168	168	5	8	3	2,5
1 800	2 600	4,76	114	112	154	168	171	5	10	3	2,5
1 700	2 400	7,90	127	114	184	201	197	6	12,5	4	3
1 600	2 200	14,0	123	114	177	201	200	8	17,5	4	3
1 900	2 800	2,42	116	115	143	150	154	6	9	2,5	2
1 800	2 600	4,26	122	117	165	178	177	6	9	3	2,5
1 800	2 600	5,90	120	117	161	178	180	5	10	3	2,5
1 500	2 000	14,5	128	119	185	211	209	9	18,5	4	3
1 800	2 600	3,06	122	120	152	160	163	7	9	2,5	2
1 700	2 400	5,00	129	122	174	188	187	6	9	3	2,5
1 700	2 400	6,90	126	122	170	188	190	6	10	3	2,5
1 600	2 200	12,5	141	124	206	226	220	8	12,5	4	3
1 400	1 900	16,4	137	124	198	226	222	9	19,5	4	3
1 700	2 400	3,25	131	130	161	170	173	7	9	2,5	2
1 600	2 200	6,01	140	132	187	203	201	6	9,5	3	2,5
1 600	2 200	8,59	136	132	181	203	204	7	11,5	3	2,5
1 500	2 000	13,6	152	134	221	246	237	10	13,5	4	3
1 300	1 800	24,5	148	134	213	246	239	9	21,5	4	3
1 600	2 200	4,93	144	140	178	190	192	8	11	2,5	2
1 500	2 000	7,60	152	144	203	216	217	7	9,5	4	3
1 500	2 000	10,7	146	144	193	216	219	7	13,5	4	3

Tapered roller bearings, single row

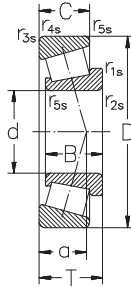

Dimensions					Designation				ISO series	Basic radial load. Factors					
d	D	B	C	T	r _{1s} , r _{2s} min. min.	r _{3s} , r _{4s} min.	r ₅	a	dyn. C _r	e	Y	stat. C _{0r}	Y ₀		
mm									—	—	—	—	—		
130	280	58	49	63,75	5	4	1,5	51	30326 A	2GB	640	0,35	1,7	820	0,9
	280	66	44	72	5	4	1,5	87	31326 XA	7GB	597	0,83	0,7	761	0,4
	280	93	78	98,75	5	4	1,5	66	32326 A	-	947	0,35	1,7	1333	0,9
140	210	45	34	45	2,5	2	0,6	46	32028 XA	4DC	312	0,46	1,3	529	0,7
	250	42	36	45,75	4	3	1	47	30228 A	4FB	396	0,43	1,4	527	0,8
	250	68	58	71,75	4	3	1	60	32228 A	4FD	602	0,43	1,4	907	0,8
	300	70	47	77	5	4	1,5	90	31328 XA	7GB	714	0,83	0,7	935	0,4
150	225	48	36	48	3	2,5	1	49	32030 XA	4EC	355	0,46	1,3	620	0,7
	270	45	38	49	4	3	1	50	30230 A	4GB	457	0,43	1,4	618	0,8
	270	73	60	77	4	3	1	64	32230 A	4GD	705	0,43	1,4	1 080	0,8
160	240	51	38	51	3	2,5	1	52	32032 XA	4EC	402	0,46	1,3	696	0,7
	290	48	40	52	4	3	1	54	30232 A	4GB	520	0,43	1,4	710	0,8
	290	80	67	84	4	3	1	70	32232 A	4GD	840	0,43	1,4	1 400	0,8
170	230	38	30	38	2,5	2	0,6	42	32934 A	3DC	280	0,37	1,6	572	0,9
	260	57	43	57	3	2,5	1	56	32034 XA	4EC	480	0,44	1,4	865	0,8
	310	52	43	57	5	4	1,5	58	30234 A	4GB	610	0,43	1,4	844	0,8
	310	86	71	91	5	4	1,5	75	32234 A	4GD	889	0,43	1,4	1 377	0,8
180	250	45	34	45	2,5	2	0,6	53	32936 A	4DC	350	0,48	1,3	727	0,7
	280	64	48	64	3	2,5	1	59	32036 XA	3FD	599	0,43	1,4	1 037	0,8
	320	52	43	57	5	4	1,5	61	30236 A	4GB	584	0,46	1,3	825	0,7
	320	86	71	91	5	4	1,5	78	32236 A	4GD	974	0,46	1,3	1 571	0,7
190	260	45	34	45	2,5	2	0,6	55	32938 A	4DC	358	0,48	1,3	772	0,7
	290	64	48	64	3	2,5	1	62	32038 XA	4FD	609	0,44	1,4	1 077	0,8
	340	92	75	97	5	4	1,5	81	32238 A	4GD	1 080	0,43	1,4	1 860	0,8
200	280	51	39	51	3	2,5	1	53	32940 A	3EC	474	0,4	1,5	950	0,8
	310	70	53	70	3	2,5	1	66	32040 XA	4FD	716	0,43	1,4	1 356	0,8
	310	70	53	70	3	2,5	1	66	T-32040 X	4FD	716	0,43	1,4	1 356	0,8
	310	70	53	70	3	2,5	1	66	T-32040 XP5	4FD	716	0,43	1,4	1 356	0,8
	360	98	82	104	5	4	1,5	83	32240 A	3GD	1 220	0,4	1,5	2 020	0,8
220	300	51	39	51	3	2,5	1	58	32944 M	3EC	407	0,43	1,4	827	0,8
	340	76	57	76	4	3	1	72	32044 XA	4FD	850	0,43	1,4	1 537	0,8

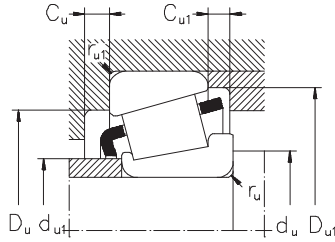

Speed limit		Weight	Mounting dimensions								
grease	oil		d _{u1} max.	d _u min.	D _u min.	max.	D _{u1} min.	C _u min.	C _{u1} min.	r _u max.	r _{u1} max.
min ⁻¹		kg	mm								
1 300	1 800	19,5	164	148	239	262	255	8	14,5	5	4
1 200	1 700	18,6	157	148	218	262	261	9	28	5	4
1 100	1 600	27,6	160	148	230	262	260	10	20,5	5	4
1 600	2 200	5,23	153	150	187	200	202	8	11	2,5	2
1 400	1 900	8,50	163	154	219	236	234	9	9,5	4	3
1 400	1 900	13,9	159	154	210	236	238	8	13,5	4	3
1 200	1 700	23,9	169	158	235	282	280	9	30	5	4
1 500	2 000	6,35	164	162	200	213	216	8	12	3	2,5
1 300	1 800	10,7	175	164	234	256	250	9	11	4	3
1 200	1 700	17,9	171	164	226	256	254	8	17	4	3
1 300	1 800	7,75	175	172	213	228	231	8	13	3	2,5
1 100	1 600	13,6	189	174	252	276	269	9	12	4	3
1 100	1 600	25,5	183	174	242	276	274	10	17	4	3
1 400	1 900	4,50	183	180	213	220	222	7	8	2,5	2
1 200	1 700	10,5	187	182	230	248	249	10	14	3	2,5
1 000	1 500	19,0	203	188	269	292	288	8	14	5	4
1 000	1 500	29,3	196	188	259	292	294	10	20	5	4
1 200	1 700	6,65	193	190	225	240	241	8	11	2,5	2
1 100	1 600	14,5	199	192	247	268	267	10	16	3	2,5
1 000	1 500	20,0	211	198	278	302	297	9	14	5	4
950	1 400	27,4	204	198	267	302	303	10	20	5	4
1 100	1 600	7,00	204	200	235	249	251	8	11	2,5	2
1 000	1 500	15,0	209	202	257	278	279	10	16	3	2,5
900	1 300	39,5	216	207	286	322	323	10	22	5	4
1 000	1 500	9,50	216	212	257	268	271	9	12	3	2,5
950	1 400	19,5	221	212	273	298	297	11	17	3	2,5
950	1 400	19,5	221	212	273	298	297	11	17	3	2,5
950	1 400	19,5	221	212	273	298	297	11	17	3	2,5
900	1 300	33,0	226	217	302	342	340	11	22	5	4
950	1 400	11,2	234	232	275	288	290	9	12	3	2,5
900	1 300	25,5	243	234	300	326	326	12	19	4	3

Tapered roller bearings, single row with flanged outer ring

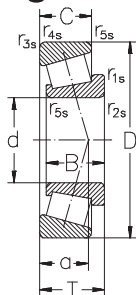

Dimensions										Designation	ISO series
d	D	B	C	T	r _{1s} , r _{2s} min.	r _{3s} , r _{4s} min.	D ₁	b	a		
mm											
20	47	14	12	6,25	1	1	51	3	11	30204 AR	2DB
25	52	15	13	6,25	1	1	57	3,5	12	30205 AR	3CC
30	62	16	14	6,75	1	1	67	3,5	14	30206 AR	3DB
	62	20	17	8,25	1	1	67	4	15	32206 AR	3DC
	72	19	16	8,75	1,5	1,5	77	4	15	30306 AR	2FB
	72	27	23	11,75	1,5	1,5	77	6	18	32306 AR	2FD
35	72	17	15	7,25	1,5	1,5	77	4	15	30207 AR	3DB
	72	23	19	10,25	1,5	1,5	77	4,5	17	32207 AR	3DC
	80	21	18	8,25	2	1,5	85	4,5	16	30307 AR	2FB
	80	31	25	13,75	2	1,5	85	6	20	32307 AR	2FE
40	80	18	16	7,75	1,5	1,5	85	4	16	30208 AR	3DB
	80	23	19	10,25	1,5	1,5	85	4,5	19	32208 AR	3DC
	90	23	20	9,75	2	1,5	95	4,5	19	30308 AR	2FB
	90	33	27	14,25	2	1,5	95	6	23	32308 AR	2FD
45	85	19	16	8,75	1,5	1,5	90	4	18	30209 AR	3DB
	85	23	19	10,25	1,5	1,5	90	4,5	20	32209 AR	3DC
	100	25	22	10,25	2	1,5	106	5	21	30309 AR	2FB
	100	36	30	15,25	2	1,5	106	7	25	32309 AR	2FD
50	90	20	17	8,75	1,5	1,5	95	4	19	30210 AR	3DB
	90	23	19	10,25	1,5	1,5	95	4,5	21	32210 AR	3DC
	110	27	23	11,25	2,5	2	116	5	23	30310 AR	2FB
	110	40	33	17,25	2,5	2	116	8	27	32310 AR	2FD
55	100	21	18	9,25	2	1,5	106	4,5	20	30211 AR	3DB
	100	25	21	10,75	2	1,5	106	5	22	32211 AR	3DC
	120	43	35	18,5	2,5	2	127	8	29	32311 AR	2FD
60	110	22	19	9,25	2	1,5	116	4,5	22	30212 AR	2EB
	110	28	24	10,75	2	1,5	116	5	24	32212 AR	2EC
	130	46	37	19,5	3	2,5	137	8	31	32312 AR	2FD
65	120	23	20	9,25	2	1,5	127	4,5	23	30213 AR	3EB
	120	31	27	11,75	2	1,5	127	6	27	32213 AR	3EC
70	125	24	21	10,25	2	1,5	132	5	25	30214 AR	3EB
	125	31	27	12,25	2	1,5	132	6	28	32214 AR	3EC

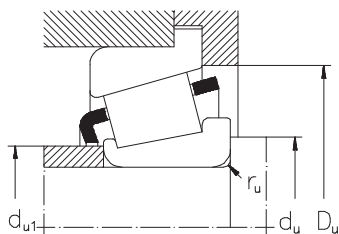

Basic radial load. Factors					Speed limit		Weight	Mounting dimensions			
dyn. C _r	e	Y	stat. C _{0r}	Y ₀	grease	oil		d _{u1} max.	d _u min.	D _u min.	r _u max.
kN	—		kN	—	min ⁻¹		kg	mm			
26	0,35	1,7	29	0,9	8 000	11 000	0,127	27	26	43	1
29,5	0,37	1,6	36	0,9	7 500	10 000	0,161	31	31	48	1
38	0,37	1,6	48	0,9	6 300	8 500	0,233	37	36	57	1
47,5	0,37	1,6	65	0,9	6 300	8 500	0,290	37	36	59	1
53	0,31	1,9	65	1,1	5 600	7 500	0,398	39	37	66	1,5
72,3	0,31	1,9	97	1,1	5 300	7 000	0,577	40	37	66	1,5
49,4	0,37	1,6	58	0,9	5 300	7 000	0,338	44	42	67	1,5
61,6	0,37	1,6	80	0,9	5 300	7 000	0,422	43	42	67	1,5
68,2	0,31	1,9	83	1,1	5 000	6 700	0,543	45	44	74	2
88,2	0,31	1,9	120	1,1	4 800	6 300	0,760	44	44	74	2
58,5	0,37	1,6	70	0,9	4 800	6 300	0,440	49	47	74	1,5
71	0,37	1,6	95	0,9	4 800	6 300	0,533	48	47	75	1,5
81	0,35	1,7	105	0,9	4 500	6 000	0,725	52	49	82	2
110	0,35	1,7	156	0,9	4 000	5 300	1,027	50	49	82	2
63	0,4	1,5	83	0,8	4 500	6 000	0,491	54	52	80	1,5
75	0,4	1,5	103	0,8	4 500	6 000	0,584	53	52	80	1,5
101	0,35	1,7	130	0,9	4 000	5 300	0,958	59	54	92	2
132	0,35	1,7	188	0,9	3 600	4 800	1,30	56	54	93	2
70,5	0,43	1,4	95	0,8	4 300	5 600	0,552	58	57	85	1,5
76,5	0,43	1,4	106	0,8	4 300	5 600	0,625	58	57	85	1,5
120	0,35	1,7	156	0,9	3 600	4 800	1,23	65	60	102	2,5
165	0,35	1,7	239	0,9	3 200	4 300	1,89	62	60	102	2,5
84,5	0,4	1,5	112	0,8	3 800	5 000	0,724	64	64	94	1,5
99	0,4	1,5	138	0,8	3 800	5 000	0,858	63	64	95	1,5
187	0,35	1,7	276	0,9	3 000	4 000	2,29	68	65	111	2
91,5	0,4	1,5	122	0,8	3 400	4 500	0,897	70	69	103	2
120	0,4	1,5	170	0,8	3 400	4 500	1,14	69	69	104	2
216	0,35	1,7	318	0,9	2 600	3 600	1,92	74	72	120	3
110	0,4	1,5	147	0,8	3 000	4 000	1,14	77	74	113	2
142	0,4	1,5	206	0,8	3 000	4 000	1,54	76	74	115	2
120	0,43	1,4	163	0,8	3 000	4 000	1,27	81	79	118	2
150	0,43	1,4	220	0,8	2 800	3 800	1,62	80	79	119	2

Tapered roller bearings, single row, paired mounted

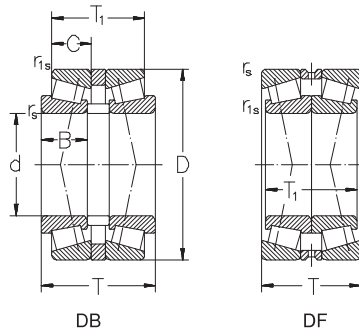

Dimensions								Designation	Speed limit		Weight
d	D	B	C	T	T ₁	r _s min.	r _{1s} min.		grease	oil	
mm								—	min ⁻¹		kg
45	85	21	19	57,5	46	1,5	0,6	32209AP2F2DBT57,5 32209AP4DBT55	3 600	4 800	1,28
	85	23	19	55	43,5	1,5	0,6		3 600	4 800	1,26
55	100	22,5 ²	21	69,5	57,66	2	0,6	32211AP2F2DBT69,5 32211AUPDBT69,5	3 000	4 000	2,06
	100	25	21	69,5	58	2	0,6		3 000	4 000	1,15
70	110	25	19	58	46	1,5	0,5	32014XADBT58	2 600	3 400	1,87
80	125	29	22	70	56	1,5	0,6	32016XADBT70	2 000	2 800	3,08
90	140	32	24	75	59	2	0,6	32018XADBT75	1 800	2 600	3,95
100	180	46	39	140	120	3	0,8	32220AS1DBT140	1 400	2 000	12,6
110	200	52,5	46	112	105	0,6	2,5	32222ADFT112 30322ADFT109	1 400	1 900	7,77
	240	50	42	109	100	1	3		1 300	1 800	12,6
120	215	58	50	123	116	0,6	2	32224ADFT123	1 300	1 800	18,7
	260	55	46	119	110	1	3	30324ADFT119	1 200	1 600	29,8
	260	86	69	181	172	1	3	32324ADFT181	1 000	1 400	46,2
130	200	45	34	90	90	0,6	2	32026XAP50DFT90 32226ADFT135,5 31326ADFT144	1 300	1 800	10,6
	230	64	54	135,5	128	1	3		1 200	1 600	23,1
	280	66	45	144	132	2	4		950	1 400	40,5
140	250	68	58	163,5	136	3	1	32228ADBT164	1 100	1 500	30,9
170	310	86	71	202	162	5	1,5	32234AMDBT202 32234AMP5DBT202	800	1 200	64,1
	310	86	71	202	162	5	1,5		800	1 200	64,1

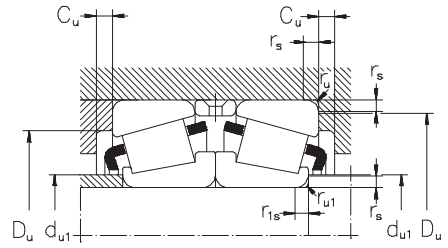
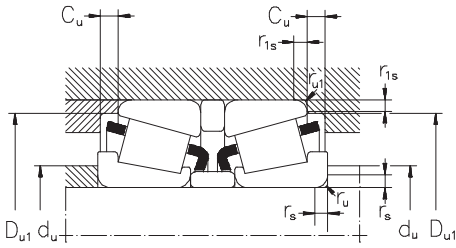

Basic radial load. Factors

Mounting dimensions

dyn. C_r	e	Y_1	Y_2	stat. C_{0r}	Y_0	d_u min./max.	D_u min.	max.	C_u min.	r_u max.	r_{u1} max.
kN	—			kN	—	mm					
125	0,4	1,7	2,5	185	1,6	52	80		5,5	1,5	0,6
125	0,4	1,7	2,5	185	1,6	52	80		5,5	1,5	0,6
155	0,4	1,7	2,5	230	1,6	64	95		5,5	1,5	0,6
155	0,4	1,7	2,5	230	1,6	64	95		5,5	1,5	0,6
155	0,43	1,6	2,3	285	1,6	77	105		6	1,5	0,6
210	0,43	1,6	2,3	395	1,6	87	120		7	1,5	0,6
260	0,43	1,6	2,3	490	1,6	99	134		8	2	0,6
520	0,43	1,6	2,3	890	1,6	112	171		10	3	1
660	0,43	1,6	2,3	1 160	1,6	126	170	188	6	2,5	1
780	0,35	1,9	2,8	1 180	1,8	141	206	226	8	3	1
720	0,43	1,6	2,3	1 310	1,6	136	181	203	7	2,5	1
920	0,35	1,9	2,8	1 420	1,8	152	221	246	10	3	1
1 290	0,35	1,9	2,8	2 210	1,8	148	213	246	9	3	1
510	0,43	1,6	2,3	1 050	1,6	144	178	190	8	2	0,6
890	0,43	1,6	2,3	1 670	1,6	146	193	216	7	3	1
970	0,83	0,8	1,2	1 520	0,8	157	218	262	9	4	1,5
980	0,43	1,6	2,3	1 810	1,6	154	238		13,5	4	1
1 440	0,43	1,6	2,3	2 750	1,6	188	294		20	5	1,5
1 440	0,43	1,6	2,3	2 750	1,6	188	294		20	5	1,5

Tapered roller bearings, single row

Inch dimensions

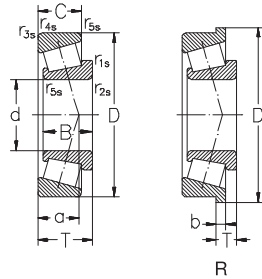

Dimensions										Designation
d	D	B	C	T	r _{1s} , r _{2s} min.	r _{3s} , r _{4s} min.	D ₁	b	a	
mm										—
11,112	34,988	10,988	8,73	10,998	1,3	1,3			9	A4044/A4138
12,7	34,988	10,988	8,73	10,998	1,3	1,3			9	A4050/4138
14,989	34,988	10,988	8,73	10,998	0,8	1,3			9	A4059/4138
17,462	39,878	14,605	10,668	13,843	1,3	1,3			9	LM11749/LM11710
19,05	45,237	16,637	12,065	15,494	1,3	1,3			10	LM11949/LM11910
	45,237	16,637	12,065	15,494	1,3	1,3			10	LM11949/LM11910
	49,225	19,05	14,288	18,034	1,3	1,3			11	09067/09195
21,43	50,005	18,288	13,97	17,526	1,3	1,3			11	M12649/M12610
	50,005	18,288	13,97	17,526	1,3	1,3			11	M12649/M12610
21,986	45,237	16,637	12,065	15,494	1,3	1,3			10	LM12749/LM12710
	45,237	16,637	12,065	15,494	1,3	1,3			10	LM12749/LM12710
	45,974	16,637	12,065	15,494	1,3	1,3			10	LM12749/LM12711
25	51,994	14,26	12,7	15,011	1,5	1,3			12	07097/07204
25,4	50,005	14,26	9,525	13,495	1	1			11	07100/07196
	50,292	14,732	10,668	14,224	1,3	1,3			11	L44643/L44610
	50,292	14,732	10,668	14,224	1,3	1,3			11	L44643/L44610
26,988	50,292	14,732	10,668	14,224	3,5	1,3			11	L44649/L44610
	50,292	14,732	10,668	14,224	3,5	1,3			11	44649/L44610
29	50,292	14,732	10,688	14,224	3,5	1,3			11	L45449/L45410
31,75	59,131	16,764	11,811	15,875	*	1,3			13	LM67048/LM67010
	59,131	16,764	11,811	15,875	*	1,3			13	LM67048/LM67010
	62	19,05	14,288	18,161	3,5	1,3			13	15123/15245
34,925	65,088	18,288	13,97	18,034	*	1,3			14	LM485448/LM48510
	65,088	18,288	13,97	18,034	*	1,3			14	LM485448/LM48510
	72,233	25,4	19,842	25,4	2,3	2,3			21	HM88649/HM88610
	76,2	28,575	23,02	29,37	3,5	3,3			23	HM89446/HM894410
34,988	59,131	16,764	11,938	15,875	*	1,3			13	L68149/L68110
	59,131	16,764	11,938	15,875	*	1,3			13	L68149/L68110
	59,974	16,764	11,938	15,875	*	1,3			13	L68149/L68111
	59,974	16,764	11,938	15,875	*	1,3			13	L68149/L68111
38	63	17	13,5	17	*	1,3			14	JL69349/JL69310
	63	17	13,5	17	*	1,3			14	JL69349/JL69310
38,1	65,088	18,288	13,97	18,04	2,3	1,3			13	LM29749/LM29710
	79,375	29,771	23,812	29,37	3,5	3,3			20	3490/3420

* Special mounting chamfer.

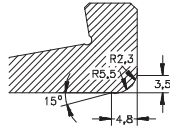

Basic radial load. Factors					Speed limit		Weight
dyn. C _r	e	Y	stat. C _{0r}	Y ₀	grease	oil	
kN	—		kN	—	min ⁻¹		kg
12,0	0,45	1,3	11,85	0,7	11 000	15 000	0,055
12,0	0,45	1,3	11,85	0,7	10 000	15 000	0,058
12,0	0,45	1,3	11,85	0,7	10 000	14 000	0,063
19,8	0,29	2,1	21,1	1,2	8 500	12 000	0,081
25,5	0,30	2,0	25,104	1,1	7 500	11 000	0,123
25,5	0,30	2,0	25,104	1,1	7 500	11 000	0,123
31,1	0,27	2,3	33,1	1,2	7 000	10 000	0,160
34,1	0,28	2,2	38	1,2	7 000	10 000	0,160
34,9	0,28	2,2	35,265	1,2	7 000	10 000	0,180
25,2	0,31	2,0	27,7	1,1	7 500	10 000	0,122
25,2	0,31	2,0	27,70	1,1	7 500	10 000	0,122
25,2	0,31	2,0	27,7	1,1	7 000	10 000	0,123
23,7	0,4	1,5	27,5	0,8	6 300	9 000	0,140
23,7	0,4	1,5	27,5	0,8	6 300	9 500	0,115
23,4	0,37	1,6	25,913	0,9	6 300	9 000	0,125
23,4	0,37	1,6	25,913	0,9	6 300	9 000	0,125
23,4	0,37	1,6	25,913	0,9	6 300	9 000	0,115
23,4	0,37	1,6	25,913	0,9	6 300	9 000	0,115
24,1	0,37	1,6	32,2	0,9	6 300	9 000	0,115
31,1	0,41	1,5	35,912	0,8	5 300	7 500	0,180
31,1	0,41	1,5	35,912	0,8	5 300	7 500	0,180
43,9	0,35	1,7	49,708	0,9	5 300	7 500	0,228
42,9	0,38	1,6	50,696	0,9	4 800	7 000	0,248
42,9	0,38	1,6	50,696	0,9	4 800	7 000	0,248
66,5	0,55	1,1	86,61	0,6	4 500	6 700	0,487
72,5	0,55	1,1	97,9	0,6	4 500	6 300	0,570
30,1	0,42	1,4	38,841	0,8	5 300	7 500	0,170
30,1	0,42	1,4	38,841	0,8	5 300	7 500	0,170
30,1	0,42	1,4	38,841	0,8	5 300	7 500	0,180
30,1	0,42	1,4	38,841	0,8	5 300	7 500	0,180
32,9	0,42	1,4	43,8	0,8	4 800	7 000	0,221
32,9	0,42	1,4	43,785	0,8	4 800	7 000	0,221
38,4	0,33	1,8	48,72	1,0	4 800	6 700	0,227
79,3	0,36	1,6	103	0,9	4 300	6 000	0,550

Tapered roller bearings, single row

Inch dimensions

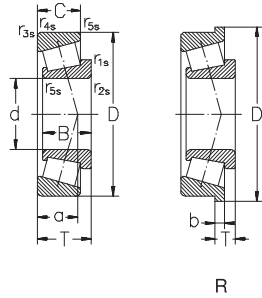

Dimensions										Designation
d	D	B	C	T	r _{1s} ,r _{2s} min.	r _{3s} ,r _{4s} min.	D ₁	b	a	
mm										—
39,688	73,025	22,098	21,336	25,654	0,8	2,3			18	M201047/M201011
41,275	73,431	19,812	14,732	19,559	3,5	0,8			16	LM501349/LM501310
44,45	73,025	18,258	15,083	18,258	1,5	1,5			14	L102849/L102810
	82,931	25,4	19,05	23,813	3,6	0,8			18	25580/25520
	95,25	28,575	22,225	27,783	0,8	0,8			20	460/453A
45,242	73,431	19,812	15,748	19,558	3,5	0,8			15	LM102949/LM102910
45,618	82,931	25,4	19,05	23,812	3,5	0,8			18	25590/25520
	82,931	25,4	22,225	26,988	3,5	2,3			19	25590/25523
46,038	85	25,608	20,638	25,4	0,8	1,3			19	2984A/2924
47,625	93,264	30,302	23,812	30,162	3,5	0,8			21	3779/3730
	93,264	30,302	23,812	30,162	3,5	0,8			21	3779/3730
50	90	22,225	15,875	8,887	2	0,8	94,661	4,762	16	365/362B cl. 3
50,8	82,55	22,225	16,51	21,59	3,5	1,3			16	LM104949/LM104911
	92,075	25,4	19,845	24,608	3,5	0,8			20	28580/28521
	95,25	28,575	22,225	27,783	3,5	0,8			20	33889/33822
	97,63	24,608	19,446	9,124	3,5	0,8	101,549	3,962	21	28678/28622B
	107,95	29,317	22,225	27,783	3,5	0,8			21	33885/33822
53,975	123,825	32,791	25,4	17,462	3,5	3,3	130,073	6,35	37	72212/72487B
57,15	104,775	29,317	24,605	30,162	2,3	3,3			23	462A/453X
	110	29,317	27	27,795	3,5	2			24	462/454
	110	29,317	27	27,795	3,5	2			24	462/454
	112,712	30,162	23,812	30,162	8	3,3			23	39581/39520
60,325	127	36,512	26,988	36,512	3,5	3,3			32	HM813841/HM813810
63,485	95	15,5	12	17	1	1			28	L910349/L910310
63,5	92,075	12,7	9,525	13,495	1,5	1,5			16	LL510749/LL510710
	112,712	30,048	23,812	11,112	3,5	3,3	117,373	4,762	25	3982/3920B
	112,712	30,048	23,812	30,162	3,5	3,3			25	3982/3920
	112,712	30,048	23,812	30,162	3,5	0,8			25	3982/3928
	112,712	30,048	23,812	30,162	3,5	3,3			25	3982/3920
	112,712	30,048	23,812	30,162	3,5	0,8			25	3982/39208
	112,712	30,162	23,812	30,162	3,5	3,3			23	39585/39520
	120	29,007	23,444	29,007	3,5	3,3			26	483/472A
	122,238	38,43	29,77	38,305	3,5	2			27	X3962/X3963
	66,675	110	25,4	19,05	25,4	3,5	1,3			24
112,712		30,048	23,812	30,162	3,5	3,3			25	3984/3920
122,238		38,354	29,718	38,1	3,5	3,3			27	HM212049/HM212011

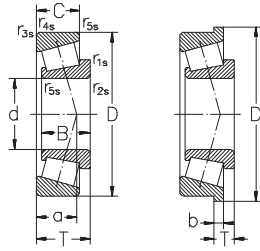

R

Basic radial load. Factors					Speed limit		Weight
dyn. Cr	e	Y	stat. C0r	Y0	grease	oil	
kN	—		kN	—	min ⁻¹		kg
57,5	0,33	1,8	72,0	1,0	4 300	6 300	0,460
48,6	0,40	1,5	64,3	0,8	4 300	6 000	0,320
47,0	0,32	1,9	68,9	1,0	4 300	6 000	0,300
75,7	0,33	1,8	95,1	1,0	3 800	5 600	0,554
96,8	0,33	1,8	127,0	1,0	3 600	5 000	0,970
97,8	0,34	1,8	134	1,0	3 000	4 500	1,10
48,5	0,31	2,0	66,4	1,1	4 000	6 000	0,300
70	0,33	1,8	95,2	1,0	3 800	5 300	0,550
70	0,33	1,8	95,2	1,0	3 800	5 300	0,580
68,3	0,35	1,7	97	1,0	3 800	5 300	0,600
98,0	0,34	1,8	128	1,0	3 400	5 000	0,905
98,0	0,34	1,8	128	1,0	3 400	5 000	0,905
74,3	0,32	1,9	87,26	1,0	3 400	5 000	0,554
65,2	0,31	2,0	86,2	1,1	3 600	5 300	0,411
71	0,38	1,6	103	0,9	3 400	4 800	0,690
102	0,33	1,8	135	1,0	3 400	4 800	0,860
101	0,40	1,5	147	0,8	3 400	4 800	0,850
143	0,74	0,8	162	0,4	2 800	4 000	2,10
97,8	0,34	1,8	134	1,0	3 000	4 300	1,10
97,8	0,34	1,8	134	1,0	3 000	4 500	1,10
109	0,34	1,8	139	1,0	3 000	4 300	1,22
109	0,34	1,8	139	1,0	3 000	4 300	1,22
130	0,34	1,8	196	1,0	2 800	4 000	1,03
161	0,50	1,2	226	0,7	2 600	3 800	2,16
42,3	0,78	0,8	56,8	0,4	3 000	4 500	0,400
31,2	0,40	1,5	46,0	0,8	3 200	4 500	0,250
116	0,40	1,5	174	0,8	2 800	4 000	1,26
116	0,40	1,5	174	0,8	2 800	4 000	1,24
116	0,40	1,5	174	0,8	2 800	4 000	1,24
116	0,40	1,5	174	0,8	2 800	4 000	1,24
116	0,40	1,5	174	0,8	2 800	4 000	1,24
130	0,34	1,8	196	1,0	2 800	4 000	1,22
133	0,38	1,6	167	0,9	2 600	3 800	1,44
189	0,34	1,8	248	1,0	2 600	3 800	2,03
92,0	0,44	1,4	138	0,7	2 800	4 000	0,900
113	0,40	1,5	172	0,8	2 800	4 000	1,20
189	0,34	1,8	248	1,0	2 600	3 800	1,92

Tapered roller bearings, single row

Inch dimensions

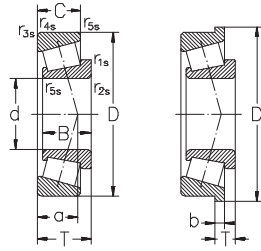

R

Dimensions										Designation
d	D	B	C	T	r _{1s} ,r _{2s} min.	r _{3s} ,r _{4s} min.	D ₁	b	a	
mm										—
71,438	127	36,17	28,575	36,512	3,5	3,3			28	567A/563 cl. 3
	136,525	46,038	36,512	46,038	3,5	3,3			38	H715345/H715311
	136,525	46,038	36,512	46,038	3,5	3,3			38	H715345/H715311
73,025	127	36,17	28,575	36,512	3,5	3,3			28	567/563 cl. 3
	146,05	41,275	31,75	41,275	3,5	3,3			34	657/653
	146,05	41,275	31,75	41,275	3,5	3,3			34	657/653
76,2	139,992	36,098	28,575	36,512	3,5	3,3			31	575/572
	161,925	55,1	42,862	53,975	3,5	3,3			40	6576/6535
	161,925	55,1	42,862	53,975	3,5	3,3			40	6576/6535
77,788	120	23,012	16	23	3,5	2,3			24	34306/34472X
	120	23,012	16	23	3,5	2,3			24	34306/34472X
82,55	139,992	36,098	28,575	36,512	3,5	3,3			31	580/572
	146,05	41,275	31,75	41,275	3,5	3,3			34	663/653
	161,925	48,26	38,1	47,625	3,5	3,3			35	757/752
	161,925	48,26	38,1	47,625	3,5	3,3			35	757/752
85,725	133,35	29,769	25,4	33,338	3,5	3,3			31	497/492W cl. 0
	146,05	41,275	31,75	41,275	6,4	3,3			34	665A/653 cl. 0
88,9	152,4	39,688	30,163	39,688	6,4	3,3			34	HM518445/HM518410
	190,5	57,531	46,038	57,15	8	3,3			41	HM221434/HM221410
89,974	146,975	40	32,5	40	7	3,5			31	HM218248/HM218210
92	140	30	22	30	3,5	1,5			32	LM718947/XC18140D
	140	30	22	30	3,5	1,5			32	LM718947/XC18140D
92,075	152,4	36,322	30,162	39,688	6,4	3,3			35	598A/592A
	171,45	48,26	38,1	47,625	3,5	3,3			37	77362/77675
	171,45	48,26	38,1	47,625	3,5	3,3			37	77362/77675
95,25	148,43	28,971	21,433	28,575	3	3			33	42375/42584
	148,43	28,971	21,433	28,575	3	3			33	42375/42584
	152,4	36,322	30,162	15,875	3,5	3,3	158,648	6,35	35	594/592 cl. 0
96,838	149,225	28,971	24,608	12,7	3,5	3,3	154,681	5,558	34	42381/42587B cl. 3
100,012	157,162	36,116	26,195	36,512	3,5	3,3			36	52393/52618 cl. 0
101,6	180,975	48,006	38,1	17,462	3,5	3,3	188,798	7,938	40	780/772B cl. 0
	212,725	66,675	53,975	66,675	7	3,3			48	HH224335/HH224310
	212,725	66,675	53,975	66,675	7	3,3			48	HH224335/HH224310

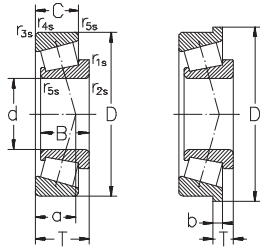

R

Basic radial load. Factors

Speed limit

Weight

dyn. Cr	e	Y	stat. C0r	Y0	Speed limit		Weight
					grease	oil	
kN	—	—	kN	—	min ⁻¹	—	kg
161	0,36	1,7	226	0,9	2 400	3 600	1,64
219	0,48	1,2	296	0,7	2 400	3 400	2,91
219	0,48	1,2	296	0,7	2 400	3 400	2,91
161	0,36	1,7	226	0,9	2 400	3 400	2,68
213	0,41	1,5	307	0,8	2 200	3 200	3,31
213	0,41	1,5	307	0,8	2 200	3 200	3,31
184	0,40	1,5	239	0,8	2 200	3 200	2,35
327	0,40	1,5	448	0,8	2 000	3 000	5,37
327	0,40	1,5	448	0,8	2 000	3 000	5,37
84,91	0,45	1,3	117	0,7	2 400	3 600	0,836
84,91	0,45	1,3	117	0,7	2 400	3 600	0,836
168	0,40	1,5	247	0,8	2 200	3 200	2,13
201	0,41	1,5	286	0,8	2 200	3 000	2,73
272	0,34	1,8	358	1,0	2 000	2 800	4,70
272	0,34	1,8	358	1,0	2 000	2 800	4,70
135	0,45	1,3	203	0,7	2 200	3 200	1,34
213	0,41	1,5	307	0,8	2 200	3 000	2,60
235	0,40	1,5	338	0,8	2 000	3 000	2,80
395	0,34	1,8	526	1,0	1 800	2 600	8,85
220	0,33	1,8	386	1,0	2 000	3 000	2,59
140	0,48	1,3	213	0,7	2 200	3 000	1,52
140	0,48	1,3	213	0,7	2 200	3 000	1,52
174	0,44	1,4	268	0,7	2 000	2 800	2,59
305	0,37	1,6	416	0,9	1 900	2 600	4,79
305	0,37	1,6	416	0,9	1 900	2 600	4,79
136	0,49	1,2	416	0,7	2 000	2 800	1,72
136	0,49	1,2	416	0,7	2 000	2 800	1,72
204	0,44	1,4	313	0,7	2 000	2 800	2,64
136	0,49	1,2	210	0,7	2 000	2 800	1,74
142	0,47	1,3	195	0,7	1 900	2 800	2,47
321	0,39	1,6	462	0,9	1 700	2 400	5,50
557	0,33	1,8	783	1,0	1 600	2 200	11,1
557	0,33	1,8	783	1,0	1 600	2 200	11,1

Tapered roller bearings, single row

Inch dimensions

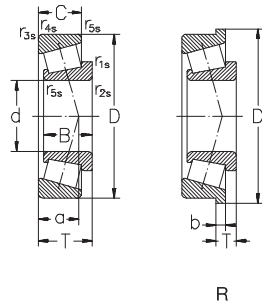

Dimensions										Designation
d	D	B	C	T	r _{1s} ,r _{2s} min.	r _{3s} ,r _{4s} min.	D ₁	b	a	
mm										—
120,65	174,625	36,512	27,783	35,72	3,5	1,5			32	M224749/M224710
	174,625	36,512	27,783	35,72	3,5	1,5			32	M224749/M224710
	206,375	47,625	34,925	47,625	3,5	3,5			45	795/792
127	215,9	47,625	34,925	47,625	3,5	3,3			49	74500/74850
130	234,95	63,5	49,213	63,5	6	3,3			50	95512/95925
133,35	215,9	47,625	34,925	20,638	3,5	3,3	223,733	7,938	49	74525/74850B cl. 0
136,525	215,9	47,625	34,925	20,638	3,5	3,3	223,733	7,938	49	74537/74850B cl. 0
139,7	215,9	47,625	34,925	20,638	3,5	3,3	223,733	7,938	49	74550/74850B
	215,9	47,625	34,925	20,638	3,5	3,3	223,733	7,938	49	74550/74850B cl. 0
	215,9	47,625	34,925	47,625	3,5	3,3			49	74550/74850
	215,9	47,625	34,925	47,625	3,5	3,3			49	74550/74850 cl.0
158,75	225,425	39,688	33,338	13,495	3,5	3,3	230,881	5,558	43	46780/46720B cl. 0
	225,425	39,688	33,338	41,275	3,5	3,3			43	46780/46720 cl. 0
180	250	45	37	47	3	3			55	JM736149/JM736110
196,85	254	27,783	21,433	28,575	1,5	1,5			41	L540049/L540010
203,2	261,142	27,783	21,433	28,575	1,5	1,5			44	LL641149/LL641110
209,55	282,575	46,038	36,512	46,038	3,5	3,3			62	67989/67920
	317,5	63,5	46,038	63,5	4,3	3,3			62	93825/93125 cl. 3
234,95	327,025	52,388	36,512	52,388	6,4	3,3			59	8575/8520
	327,025	52,388	36,512	52,388	6,4	3,3			59	8575/8520 cl. 3
241,3	327,025	52,388	36,512	25,4	6,4	3,3	336,448	9,525	59	8578/8520B
	327,025	52,388	36,512	25,4	6,4	3,3	336,448	9,525	59	8578/8520B cl. B

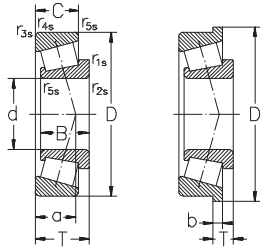

R

Basic radial load. Factors

dyn. Cr	e	Y	stat. C0r	Y0	Speed limit	Weight	
					grease	oil	
kN	—		kN	—	min ⁻¹	kg	
220	0,33	1,8	375	1,0	1 700	2 400	2,70
317	0,46	1,3	525	0,7	1 500	2 200	6,10
308	0,49	1,2	523	0,7	1 400	2 000	6,97
507	0,36	1,6	784	0,9	1 300	1 900	11,3
313	0,49	1,2	528	0,7	1 400	2 000	6,78
313	0,49	1,2	528	0,7	1 400	2 000	6,53
310	0,49	1,2	531	0,7	1 400	2 000	6,17
310	0,49	1,2	531	0,7	1 400	2 000	6,17
310	0,49	1,2	531	0,7	1 400	2 000	6,08
310	0,49	1,2	531	0,7	1 400	2 000	6,08
305	0,38	1,6	541	0,9	1 300	1 800	5,40
305	0,38	1,6	541	0,9	1 300	1 800	5,35
334	0,48	1,3	703	0,7	1 100	1 600	7,85
170	0,39	1,5	334	0,9	1 100	1 600	3,32
174	0,41	1,5	353	0,8	1 100	1 500	3,56
331	0,51	1,2	661	0,6	1 000	1 400	8,84
651	0,52	1,2	1 098	0,6	950	1 300	18,5
468	0,41	1,5	934	0,8	850	1 200	12,3
468	0,41	1,5	934	0,8	850	1 200	12,3
468	0,41	1,5	934	0,8	850	1 200	11,9
468	0,41	1,5	934	0,8	850	1 200	11,9

Tapered roller bearings, double row

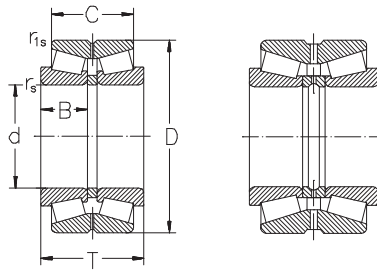

d<220

d>220

Dimensions							Designation
d	D	B	C	T	r ₁ min.	r _{1s} min.	
mm							—
160	240	48	94	115	3	1	35032
180	280	60	108	134	3	1	35036
200	310	66	123	152	3	1	35040
220	340	72	130	165	4	1	35044

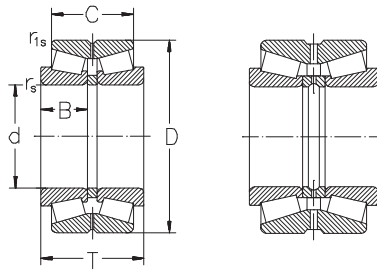

d<220

d>220

Basic radial load. Factors						Speed limit		Weight
dyn. Cr	e	Y ₁	Y ₂	stat. C _{0r}	Y ₀	grease	oil	
kN	—			kN	—	min ⁻¹		kg
662	0,37	1,8	2,7	1 288	1,8	950	1 400	17,0
1 154	0,29	2,3	3,5	2 352	2,3	850	1 200	29,9
1268	0,37	1,0	2,7	2 526	1,8	800	1 100	39,3
1 469	0,34	2,0	2,9	3 032	1,9	750	1 000	50,1

Tapered roller bearings, double row

Inch dimensions

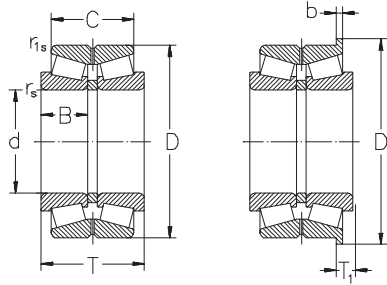

Fig. 1

Fig. 2

Dimensions							Designation
d	D	B	C	T	r ₁ min.	r _{1s} min.	
mm							—
69,85	114,287	25,4	46,038	58,738	1,5	0,8	29675/29622DC
	114,287	25,4	46,038	58,738	1,5	0,8	29675/29622DC
	120	29,007	53,975	65,09	3,5	0,8	482/472D
73,025	114,287	25,4	46,038	58,738	3,5	0,8	29685/29622D
	114,287	25,4	46,038	58,738	3,5	0,8	29685/29622D
82,55	136,525	29,769	53,975	69,85	3,5	0,8	495/493D
85,725	136,525	29,769	53,975	69,85	3,5	0,8	497/493DC
92,075	149,225	28,971	52,387	66,672	3,5	0,8	42362/42587D
107,95	158,75	21,4	39,688	53,978	3,5	0,8	37425/37626D cl. 3
	159,987	34,925	58,738	74,89	3,6	0,8	LM4522546/LM522510DC
	159,987	34,925	58,738	74,89	3,6	0,8	LM4522546/LM522510DC
114,3	190,5	49,2	80,962	106,362	3,5	1,5	71450/71751D
	190,5	49,2	80,962	106,362	3,5	1,5	71450/71751D
115	190,5	50	82,6	108	3,5	1	181115/181190XG
127	196,85	46	85,725	101,6	3,5	0,8	67388/67322D
	196,85	46	85,725	101,6	3,5	0,8	67388/67322D
136,525	190,5	39,7	73,025	85,725	3,5	0,8	48393/48320D
	215,9	51	92	110	2,5	1	200136X/200215XH ¹⁾
152,4	222,25	46,8	76,2	100,01	3,5	0,8	M231649/M231610D
	222,25	46,8	76,2	100,01	3,5	0,8	M231649/M231610D
	222,25	46,8	76,2	100,01	3,5	0,8	M231649/M231610D cl. 3
203,2	282,575	46,038	82,55	101,6	3,5	0,8	67983/67920DC cl. 0
	282,575	46,038	82,55	101,6	3,5	0,8	67983/67920DC cl.0

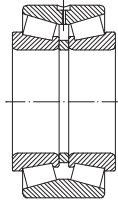

Fig. 3

Basic radial load. Factors					Speed limit		Weight	Fig.	
dyn. C _r	e	Y ₁	Y ₂	stat. C _{0r}	Y ₀	grease	oil		
kN	—			kN	—	min ⁻¹	kg		
180	0,49	1,4	2,1	295	1,4	2 400	3 000	2,05	3
180	0,49	1,4	2,1	295	1,4	2 400	3 000	2,05	3
255	0,38	1,8	2,6	415	1,7	2 200	2 800	2,45	1
180	0,49	1,4	2,1	295	1,4	2 400	2 800	1,91	1
180	0,49	1,4	2,1	295	1,4	2 400	2 800	1,91	1
255	0,44	1,5	2,3	450	1,5	2 000	2 400	3,84	1
255	0,44	1,5	2,3	450	1,5	1 900	2 400	3,72	3
275	0,49	1,4	2,1	510	1,4	1 800	2 200	4,37	1
170	0,61	1,1	1,7	335	1,1	1 600	2 000	3,26	1
280	0,40	1,7	2,5	630	1,6	1 600	2 000	4,97	3
280	0,40	1,7	2,5	630	1,6	1 600	2 000	4,97	3
530	0,42	1,6	2,4	980	1,6	1 400	1 800	10,8	1
530	0,42	1,6	2,4	980	1,6	1 400	1 800	10,8	1
435	0,26	2,6	3,8	750	2,5	1 400	1 800	10,1	1
540	0,34	2,0	2,9	1 130	1,9	1 300	1 700	10,6	1
540	0,34	2,0	2,9	1 130	1,9	1 300	1 700	10,6	1
395	0,33	2,1	3,1	940	2,0	1 300	1 700	6,88	1
540	0,25	2,7	4,1	960	2,7	1 200	1 500	12,2	2
540	0,33	2,0	3,0	1 190	2,0	1 200	1 400	11,7	1
540	0,33	2,0	3,0	1 190	2,0	1 200	1 400	11,7	1
540	0,33	2,0	3,0	1 190	2,0	1 200	1 400	11,7	1
600	0,51	1,3	2,0	1 410	1,3	900	1 100	17,8	1
600	0,51	1,3	2,0	1 410	1,3	900	1 100	17,8	1