

SPHERICAL BUSHINGS

- Steel-on-steel Spherical Bushings
- Maintenance-free Spherical Bushings



Structure and Features

IKO Spherical Bushings are self-aligning spherical plain bushings that have inner and outer rings with spherical sliding surfaces, and can take a large radial load and a bi-directional axial load at the same time. There are many types of Spherical Bushings, but they are basically divided into steel-on-steel types and maintenance-free types according to the kind of sliding surfaces.

Steel-on-steel Spherical Bushings have inner and outer rings of high carbon chromium bearing steel, of which sliding surfaces are phosphate-treated and then dry-coated with molybdenum disulfide (MoS₂). They can, therefore, operate with low torque, and have excellent wear resistance and large load capacity. They are especially suitable for applications where there are alternate loads and shock loads. They have wide applications mainly in industrial and construction machinery.

Maintenance-free Spherical Bushings consist of an outer ring which has a special PTFE liner reinforced with copper alloy meshes on the sliding surface, and a spherical inner ring of which sliding surface has a hard chromium plating. Creep deformation due to compressive load is small, and wear resistance is superior. Thus, they are maintenance-free and can be used for extended periods of time without re-lubrication. They are especially suitable in cases where fixed directional loads are applied and are used mainly in food processing machines and construction machinery and in other applications in which the use of oil is undesirable or lubrication is not possible.

Types

Spherical Bushings are available in various types shown in Table 1.

Table 1 Type of bearing

Type	Steel-on-steel		Maintenance-free	
	Without seals	With seals	Without seals	With seals
Metric	SB	—	GE···EC	GE···EC-2RS
	SB···A	—		
	GE···E, ES	GE···ES-2RS		
	GE···G, GS	GE···GS-2RS		
Inch	SBB	SBB···-2RS	—	—

Structures of Spherical Bushings

Steel-on-steel type

SB···A

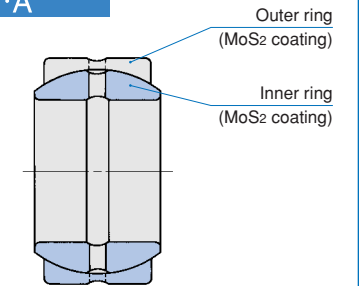

Steel-on-steel type

GE···ES-2RS

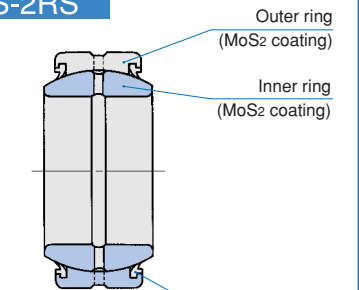

Maintenance-free type

GE···EC

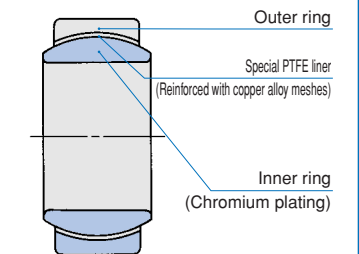

Maintenance-free type

GE···EC-2RS

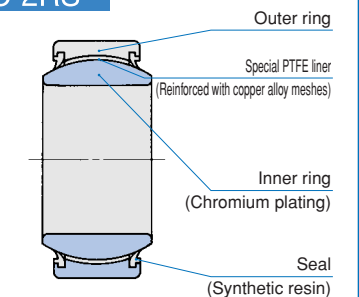

K

SB
GE
SBB

Steel-on-steel Spherical Bushings SB

These bushings have an outer ring split into halves. The split outer ring and the inner ring are held together by a snap ring placed in the groove around the outer periphery of the outer ring.

Steel-on-steel Spherical Bushings SB...A

These bushings have an outer ring split only at one position, and therefore, the outer and inner rings will not separate. Handling before mounting and mounting to the housing are simple. The boundary dimensions are the same as those of the SB type. Therefore, SB and SB...A types are dimensionally interchangeable, but the radial internal clearances of the SB...A type are smaller than those of the SB type.

Steel-on-steel Spherical Bushings GE...E, GE...ES

The dimension series of these types conform to ISO standards and they can be used internationally. The outer ring is split at one position. The GE...E and GE...ES types are available. These are classified by bushing size.

The GE...ES type can be provided with seals, which are double-lip type polyurethane seals effective for prevention against grease leakage and dust penetration. The sealed type is indicated by the suffix "-2RS" at the end of the identification number.

Steel-on-steel Spherical Bushings GE...G, GE...GS

As compared with the GE...E and GE...ES types, these bushings have larger load capacities and larger permissible tilting angles. The dimension series also conform to ISO standards, and they can be used internationally. The outer ring is split at one position. The GE...G and GE...GS types are available. They are classified by bushing size.

The GE...GS type can be provided with seals, which are double-lip type polyurethane seals effective for prevention against grease leakage and dust penetration.

Steel-on-steel Spherical Bushings SBB

These are inch series bushings. The outer ring is split at one position.

These bushings can be provided with seals, which are double-lip type polyurethane seals effective for prevention against grease leakage and dust penetration.

Maintenance-free Spherical Bushings GE...EC

These bushings have the same boundary dimensions as the GE...ES type and can be used internationally. A special PTFE liner reinforced with copper alloy meshes is used on the sliding surface. Therefore, creep deformation due to compressive loads is small, and wear resistance is superior. These bushings are used as maintenance-free bushings.

These bushings can be provided with synthetic resin seals which are effective in preventing dust penetration. They are indicated by the suffix "-2RS" at the end of the identification number.

Spherical Bushings with superior rust prevention properties, which can be used in a corrosive environment or in an environment where water splashes, are also available on request. Please consult **IKO**.

Identification number

The identification number of Spherical Bushings consists of a model code, a size and any supplemental codes. Examples are shown below.

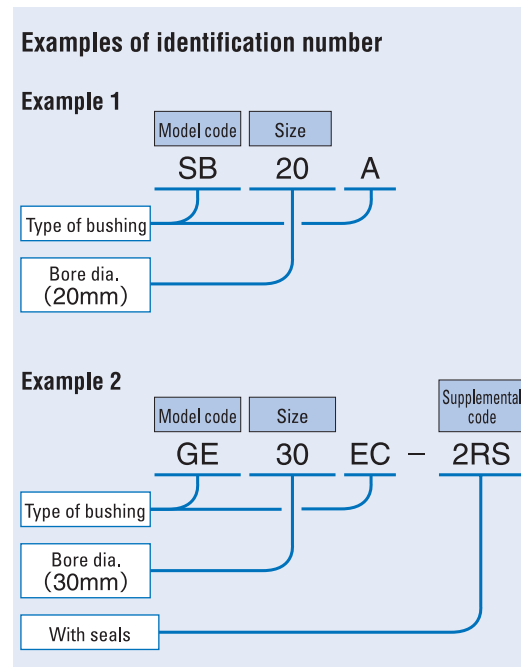

Accuracy

The tolerances of Steel-on-steel Spherical Bushings of the metric series is shown in Table 2.

The tolerances of the GE type are applicable to bushings before splitting the outer ring and after surface treatment.

The tolerances of the SB and SB...A types are applicable to bushings before splitting the outer ring and before surface treatment.

The tolerances of the GE...EC type are applicable to bushings before splitting the outer ring.

The tolerances of the Spherical Bushings of the inch series are shown in Table 3. The tolerances of the bore diameter are applicable to bushings after surface treatment, while other tolerances are applicable to bushings before splitting the outer ring and before surface treatment.

Although minor dimensional changes may occur during surface treatment, they have negligible influence on the overall performance.

Table 2 Tolerances of inner and outer rings of metric series (JIS Class 0) unit: μm

d or D ⁽¹⁾ Nominal bore dia. or outside dia. mm	Δ_{dmp} Single plane mean bore dia. deviation	Δ_{Dmp} Single plane mean outside dia. deviation		Δ_{Bs} or Δ_{Cs} Deviation of a single inner ring width or outer ring width			
		High	Low	High	Low		
Over	Incl.	High	Low	High	Low		
2.5	6	0	-8	-	-	0	-120
6	18	0	-8	0	-8	0	-120
18	30	0	-10	0	-9	0	-120
30	50	0	-12	0	-11	0	-120
50	80	0	-15	0	-13	0	-150
80	120	0	-20	0	-15	0	-200
120	150	0	-25	0	-18	0	-250
150	180	0	-25	0	-25	0	-250
180	250	0	-30	0	-30	0	-300
250	315	0	-35	0	-35	0	-350
315	400	0	-40	0	-40	0	-400
400	500	0	-45	0	-45	0	-450

Note⁽¹⁾ d for Δ_{dmp} , Δ_{Bs} and Δ_{Cs} and D for Δ_{Dmp} , respectively.

Table 3 Tolerances of inner and outer rings of inch series SBB unit: μm

d or D ⁽¹⁾ Nominal bore dia. or outside dia. mm	Δ_{dmp} Single plane mean bore dia. deviation	Δ_{Dmp} Single plane mean outside dia. deviation		Δ_{Bs} or Δ_{Cs} Deviation of a single inner ring width or outer ring width			
		High	Low	High	Low		
Over	Incl.	High	Low	High	Low		
-	50.800	0	-13	0	-13	0	-130
50.800	76.200	0	-15	0	-15	0	-130
76.200	80.962	0	-20	0	-15	0	-130
80.962	120.650	0	-20	0	-20	0	-130
120.650	152.400	0	-25	0	-25	0	-130
152.400	177.800	-	-	0	-25	0	-130
177.800	222.250	-	-	0	-30	0	-130

Note⁽¹⁾ d for Δ_{dmp} , Δ_{Bs} and Δ_{Cs} and D for Δ_{Dmp} , respectively.

Clearance

The radial internal clearances of Spherical Bushings are the values before splitting the outer ring, and are shown in Tables 4, 5 and 6. The radial internal clearances of the inch series are shown in the dimension table.

Clearances other than these can also be prepared on request. Please consult **IKO**.

Table 4 Radial internal clearance of SB and SB...A types (Steel-on-steel) unit: μm

d Nominal bore dia. mm	SB type		SB...A type	
	Min.	Max.	Min.	Max.
12			32	68
15	70	125	40	82
20				
22	75	140	50	100
25				
30				
35	85	150	60	120
40				
45				
50				
55	90	160		
60				
65				
70			72	142
75	95	170		
80				
85				
90	100	185		
95				
100			85	165
110				
115	110	200		
120				
130				
150	120	215	100	192

Table 5 Radial internal clearance of GE type (Steel-on-steel)

unit: μm

d Nominal bore dia. mm		Radial internal clearance	
GE...E GE...ES	GE...G GE...GS	Min.	Max.
4	—	32	68
5	—		
6	—		
8	6		
10	8		
12	10		
15	12	40	82
17	15		
20	17		
25	20		
30	25	50	100
35	30		
40	35		
45	40		
50	45		
60	50		
70	60	72	142
80	70		
90	80		
100	90		
110	100	85	165
120	110		
140	120		
160	140		
180	160		
200	180	100	192
220	200		
240	220		
260	240		
280	260	110	214
300	280		

Remark Also applicable to bushings with seals.

Table 6 Radial internal clearance of GE...EC type (Maintenance-free)

unit: μm

d Nominal bore dia. mm	Radial internal clearance	
	Min.	Max.
15	0	40
17		
20		
25	0	50
30		
35		
40	0	60
45		
50		
60		
70		

Remark Also applicable to bushings with seals.

Fit

The recommended fits for Spherical Bushings are shown in Tables 7 and 8.

Table 7 Recommended fits for Steel-on-steel Spherical Bushings

Condition	Tolerance class	
	Shaft	Housing bore
Normal operation	h6, j6	H7, J7
With directionally indeterminate load	m6, n6	M7, N7

Remark N7 tolerance is recommended for light metal housings.

Table 8 Recommended fits for Maintenance-free Spherical Bushings

Tolerance class of shaft	Tolerance class of housing bore
h6, j6	H7, J7, K7

Remark K7 tolerance is recommended for light metal housings.

Selection of Spherical Bushings

Selection between the steel-on-steel type and the maintenance-free type is made considering the operating conditions such as load, lubrication, temperature, and sliding velocity.

Load capacity

1 Dynamic load capacity

The dynamic load capacity C_d is the maximum allowable load that can be applied on a spherical bushing under oscillating motion. It is obtained on the basis of the contact pressure on the spherical surfaces. The dynamic load capacity is also used for calculating the life of spherical bushings.

The recommended value of bushing load is obtained by multiplying the dynamic load capacity C_d by a numerical factor, which differs depending on the bushing type and the load condition. A guideline for selection is shown in Table 9.

Table 9 Guide for determination of load

Type of bushing	Load direction	
	Constant	Alternate
Steel-on-steel	$\leq 0.3C_d$	$\leq 0.6C_d$
Maintenance-free	$\leq C_d$	$\leq 0.5C_d$

When the magnitude of load exceeds the value given in Table 9, please consult **IKO**.

The dynamic load capacity C_{dt} considering the influence of bushing temperature can be obtained from the following equation using the temperature factor.

$$C_{dt} = f_t C_d \quad \dots \dots \dots (1)$$

where, C_{dt} : Dynamic load capacity considering temperature increase N

f_t : Temperature factor (Refer to Table 10.)

C_d : Dynamic load capacity N (Refer to the dimension tables.)

Table 10 Temperature factor f_t

Type of bushing		Temperature $^{\circ}\text{C}$					
		-30 +80	+80 +90	+90 +100	+100 +120	+120 +150	+150 +180
Steel-on-steel	Without seals	1	1	1	1	1	0.7
	With seals	1	—	—	—	—	—
Maintenance-free	Without seals	1	1	0.9	0.75	0.55	—
	With seals	1	—	—	—	—	—

2 Static load capacity

The static load capacity C_s is the maximum static load that can be applied on the spherical bushing without breaking inner and outer rings or causing any permanent deformation severe enough to render the bushing unusable.

It must be noted that if the magnitude of the applied load becomes comparable to the static load capacity of bushing, the stresses in the shaft or housing may also reach to their limits. This possibility must be taken into consideration in the design.

Equivalent radial load

Spherical Bushings can take radial and axial loads at the same time. When the magnitude and direction of loads are constant, the equivalent radial load can be obtained from the following formula.

$$P = F_r + YF_a \quad \dots \dots \dots (2)$$

where, P : Equivalent radial load N

F_r : Radial load N

F_a : Axial load N

Y : Axial load factor (Refer to Table 11.)

Table 11 Axial load factor Y

F_a/F_r	0.1	0.2	0.3	0.4	0.5	>0.5
Steel-on-steel	1	2	3	4	5	Unusable
Maintenance-free	1	2	3	Unusable		

Life

The life of Spherical Bushings is defined as the total number of oscillating motions before the bushings cannot be operated normally because of wear, increase in internal clearance, increase in sliding torque, rise of operating temperature, etc.

As the actual life is affected by many factors such as the material of the sliding surface, the magnitude and direction of load, lubrication, sliding velocity, etc., the calculated life can be used as a practical measure of expected service life.

1 Life of Steel-on-steel spherical bushings

[1] Confirmation of pV value

Before attempting to calculate the life, make sure that the operating conditions are within the permissible range by referring to the pV diagram in Fig.1.

When the operating conditions are out of the permissible range, please consult **IKO**.

The contact pressure p and the sliding velocity V are obtained from the following formulae.

$$p = \frac{100P}{C_{dt}} \quad \dots \dots \dots (3)$$

$$V = 5.82 \times 10^{-4} d_k \beta f \quad \dots \dots \dots (4)$$

where, p : Contact pressure N/mm²

P : Equivalent radial load N (Refer to Formula (2).)

C_{dt} : Dynamic load capacity considering temperature increase N (Refer to Formula (1).)

V : Sliding velocity mm/s

d_k : Sphere diameter mm

(Refer to the dimension tables.)

2β : Oscillating angle degrees (Refer to Fig.2.)

when $\beta < 5^{\circ}$, $\beta = 5$

when rotating, $\beta = 90$

f : Number of oscillations per minute cpm

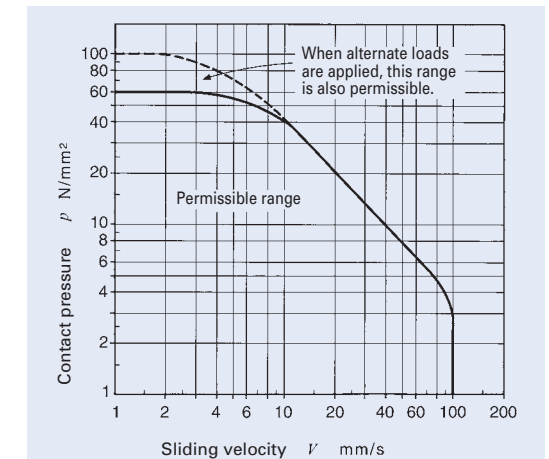

Fig.1 pV diagram of Steel-on-steel spherical bushings

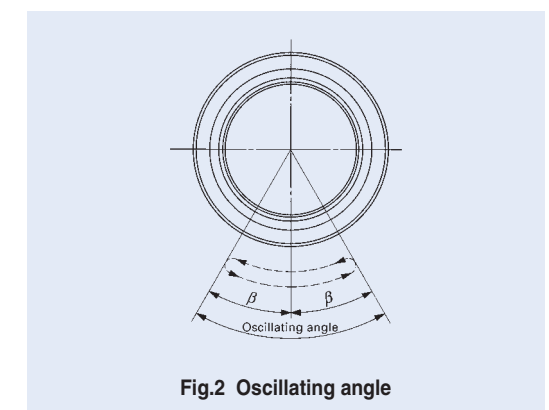

Fig.2 Oscillating angle

[2] Life calculation

The life of steel-on-steel spherical bushings can be calculated from the following formulae.

$$G = \frac{3.18b_1b_2b_3}{\sqrt{d_k\beta}} \left(\frac{C_{dt}}{P}\right)^2 \times 10^5 \dots\dots(5)$$

$$L_h = \frac{G}{60f} \dots\dots(6)$$

- where, G : Life (Total number of oscillations)
- b_1 : Load directional factor (Refer to Table 12.)
- b_2 : Lubrication factor (Refer to Table 13.)
- b_3 : Sliding velocity factor (Refer to Fig.3.)
- C_{dt} : Dynamic load capacity considering temperature increase N
(Refer to Formula (1).)
- P : Equivalent radial load N
(Refer to Formula (2).)
- L_h : Life in hours h
- f : Number of oscillations per minute cpm

Table 12 Load directional factor b_1 (Steel-on-steel)

Load direction	Constant	Alternate
Load directional factor b_1	1	5

Table 13 Lubrication factor b_2

Periodical lubrication	None	Regular
Lubrication factor b_2	1	15

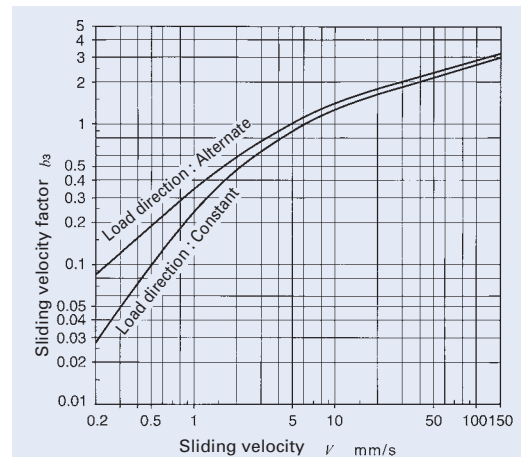

Fig.3 Sliding velocity factor

Life of Maintenance-free spherical bushings

[1] Confirmation of pV value

Before attempting to calculate the life, make sure that the operating conditions are within the permissible range by referring to the pV diagram in Fig.4.

When the operating conditions are out of the permissible range, please consult **IKO**.

The contact pressure p and the sliding velocity V are obtained from Formulae (3) and (4) shown on page 439.

[2] Life calculation

The life of maintenance-free spherical bushings is obtained from the total sliding distance S which is given in Fig.5 for the contact pressure p obtained from Formula (3).

The total number of oscillations and life in hours can be obtained from the following formulae.

$$G = 16.67 \times b_1 \frac{Sf}{V} \dots\dots(7)$$

$$L_h = \frac{G}{60f} \dots\dots(8)$$

- where, G : Life (Total number of oscillations)
- b_1 : Load directional factor (Refer to Table 14.)
- S : Total sliding distance m (Refer to Fig.5.)
- f : Number of oscillations per minute cpm
- V : Sliding velocity mm/s
- L_h : Life in hours h

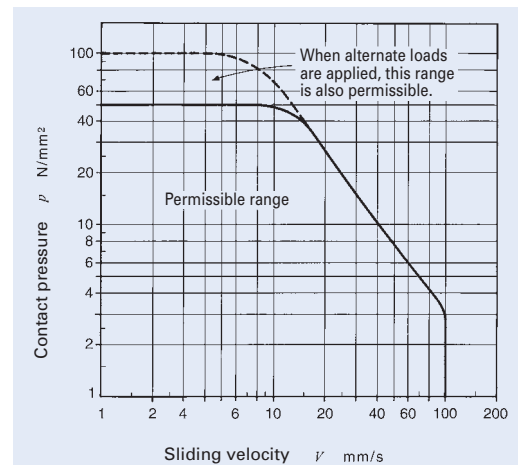

Fig.4 pV diagram of Maintenance-free spherical bushings

Table 14 Load directional factor b_1 (Maintenance-free)

Load direction	Constant	Alternate
Load directional factor b_1	1	0.2 ⁽¹⁾

Note⁽¹⁾ This value is applicable when the load changes comparatively slowly. When the load changes rapidly, please consult **IKO**, as the factor decreases sharply.

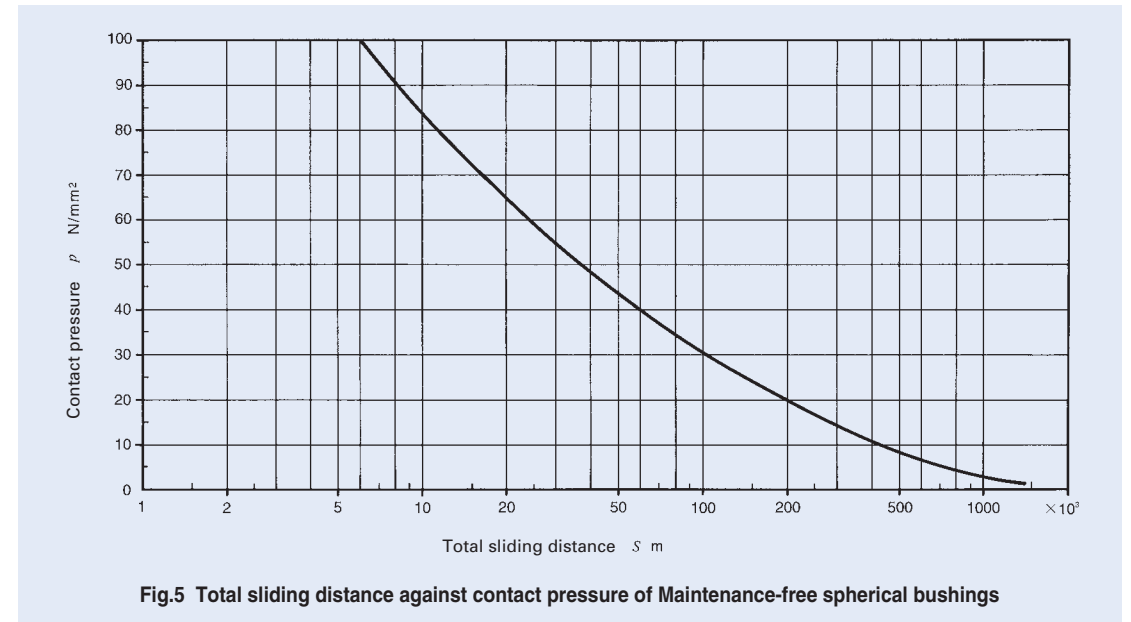

Fig.5 Total sliding distance against contact pressure of Maintenance-free spherical bushings

Lubrication

Steel-on-steel Spherical Bushings can be operated without lubrication when the magnitude of applied load is small and the sliding velocity of oscillation is small. However, in general, it is necessary to supply grease periodically. During initial operation, it is recommended to shorten the lubrication interval. Lithium soap base grease (NLGI consistency No.2) containing molybdenum disulfide (MoS₂) is widely used as the lubricating grease.

Maintenance-free Spherical Bushings can be used without lubrication. However, if lithium soap base grease is supplied before operation, the spherical bushings can be operated for an extended period of time. The spherical bushings can be effectively protected from dust and rust if the space around the bushings is filled with grease.

Oil Hole

The number of oil holes on inner and outer rings is shown in Table 15.

Table 15 Number of oil holes on inner and outer rings

Bushing type			Number of oil holes on inner and outer rings
Steel-on-steel Spherical Bushings	Metric series	GE...E	0
		GE...G	
	Inch series	SB, SB...A	2
		GE...ES, GE...GS	
Maintenance-free Spherical Bushings	Metric series	GE...EC	0

Remark Types with oil holes are also provided with oil grooves on inner and outer rings.

Operating Temperature Range

The operating temperature range for Spherical Bushings with seals is -30°C ~ +80°C. The maximum allowable temperature for Spherical Bushings without seals is +180°C for the steel-on-steel type and +150°C for the maintenance-free type.

Precautions for Use

Design of shaft

When the load is large, sliding may occur between the shaft and the inner ring bore of bushing. For such cases, it is necessary to prepare the shaft with a hardness of 58HRC or greater and surface roughness of 0.8 μmR_a or less. Furthermore, attention must be paid to the strength of shaft because the shear and/or bending stresses in the shaft may surpass the allowable values even when the load is below the static load capacity of Spherical Bushings.

Design of housing

The housing should have sufficient rigidity to avoid harmful deformation under load. When the housing shown in Fig.6 is used, it should be designed with sufficient strength as follows.

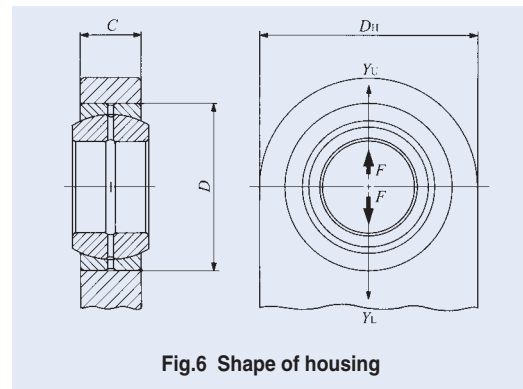

Fig.6 Shape of housing

①When the load acts in the Y_L direction; Select the housing material considering the compressive stress obtained from the following formula.

$$\sigma_1 = \frac{F}{CD} \dots\dots\dots(9)$$

- where, σ_1 : Maximum compressive stress occurring in the housing bore N/mm²
- F : Applied load N
- C : Width of outer ring and housing mm
- D : Outside diameter of outer ring mm

②When the load acts in the Yu direction ; Select the housing material considering the tensile stress obtained from the following formula.

$$\sigma_2 = \frac{F}{C(D_H - D)} k \dots\dots\dots(10)$$

- where, σ_2 : Maximum tensile stress occurring in the housing bore N/mm²
- F : Applied load N
- C : Width of outer ring and housing mm
- D_H : Outside diameter of housing mm
- D : Outside diameter of outer ring mm
- k : Stress concentration factor (Refer to Fig.7.)

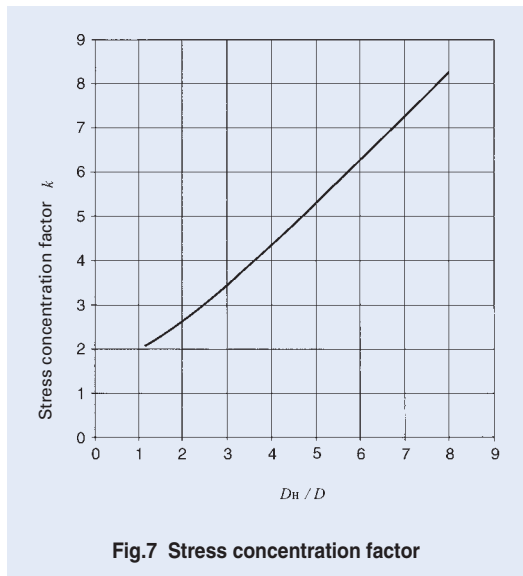

Fig.7 Stress concentration factor

Mounting

- ①When mounting Spherical Bushings, pay attention to the location of the split plane of the outer ring. Set the split plane at right angles to the direction of load to avoid the application of load to the split plane as shown in Fig. 8.
- ②The shoulder dimensions of shaft and housing are shown in the dimension tables.

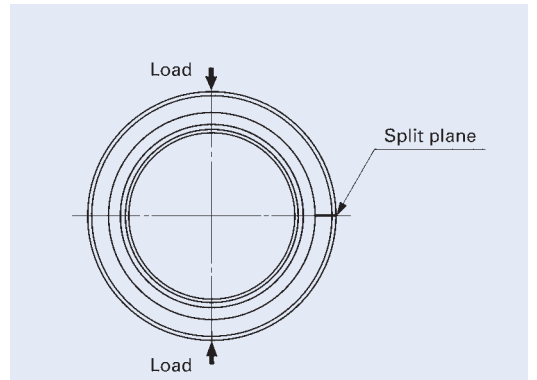

Fig.8 Relationship between the split plane and the loading direction

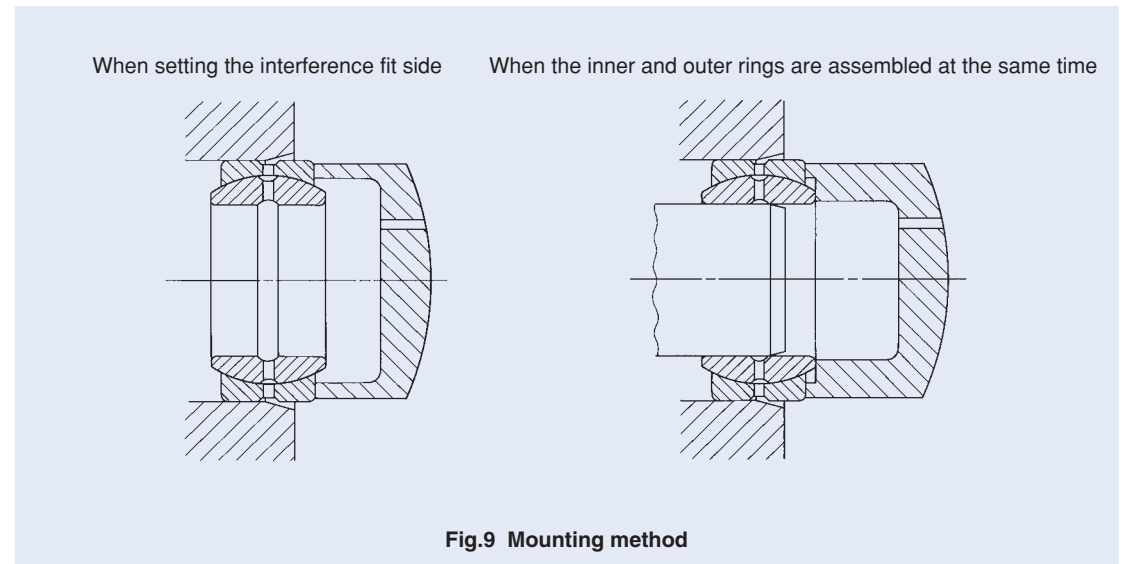

Fig.9 Mounting method

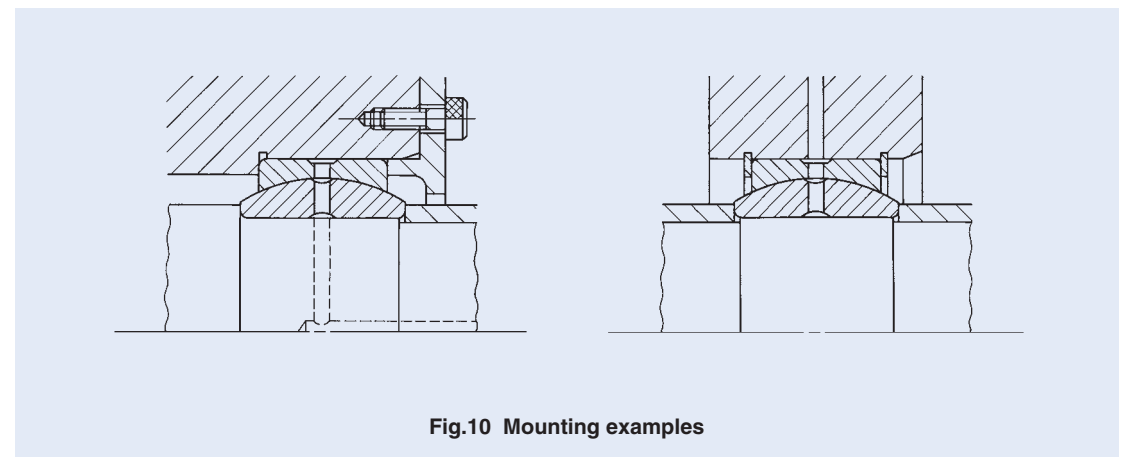

Fig.10 Mounting examples

SPHERICAL BUSHINGS

Steel-on-steel Spherical Bushings



Shaft dia. 12 – 100mm

Shaft dia. mm	Identification number		Mass (Ref.) kg	Boundary dimensions mm						Permissible tilting angle α
				d	D	B	C	d_k	$r_{s\ min}^{(1)}$	
12	SB 12A	SB 122211	0.019	12	22	11	9	18	0.3	7
15	SB 15A	SB 152613	0.028	15	26	13	11	22	0.3	6
20	SB 20A	SB 203216	0.053	20	32	16	14	28	0.3	4
22	SB 22A	SB 223719	0.085	22	37	19	16	32	0.3	6
25	SB 25A	SB 254221	0.116	25	42	21	18	36	0.3	5
30	SB 30A	SB 305027	0.225	30	50	27	23	45	0.6	6
35	SB 35A	SB 355530	0.300	35	55	30	26	50	0.6	5
40	SB 40A	SB 406233	0.375	40	62	33	28	55	0.6	6
45	SB 45A	SB 457236	0.600	45	72	36	31	62	0.6	5
50	SB 50A	SB 508042	0.870	50	80	42	36	72	0.6	5
55	SB 55A	SB 559047	1.26	55	90	47	40	80	0.6	5
60	SB 60A	SB 6010053	1.70	60	100	53	45	90	0.6	6
65	SB 65A	SB 6510555	2.05	65	105	55	47	94	0.6	5
70	SB 70A	SB 7011058	2.22	70	110	58	50	100	0.6	5
75	SB 75A	SB 7512064	3.02	75	120	64	55	110	0.6	5
80	SB 80A	SB 8013070	3.98	80	130	70	60	120	0.6	5
85	SB 85A	SB 8513574	4.29	85	135	74	63	125	0.6	6
90	SB 90A	SB 9014076	4.71	90	140	76	65	130	0.6	5
95	SB 95A	SB 9515082	6.05	95	150	82	70	140	0.6	5
100	SB 100A	SB 10016088	7.42	100	160	88	75	150	1	5

Notes⁽¹⁾ Minimum allowable value of chamfer dimensions r_1 and r_2
⁽²⁾ When Spherical Bushings are used with full tilting angle, the shaft shoulder dimension must be less than the maximum value of d_a .
 Remarks1. The inner ring and the outer ring have an oil groove and two oil holes, respectively.
 2. No grease is prepacked. Perform proper lubrication.

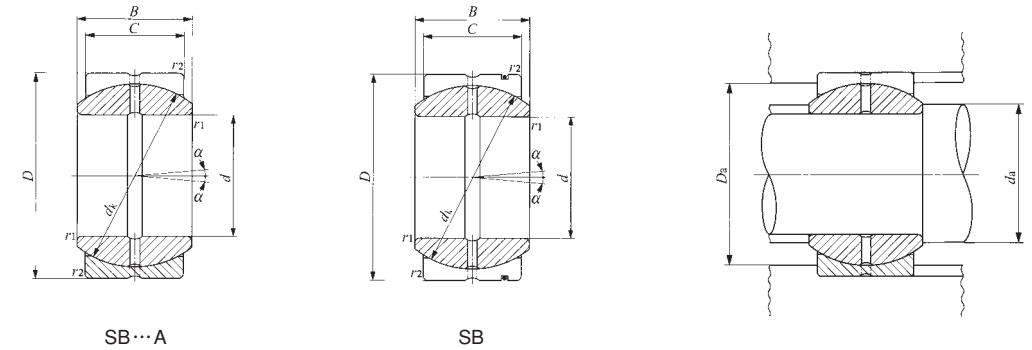

Mounting dimensions mm				Dynamic load capacity C_d N	Static load capacity C_s N
d_a		D_a			
Min.	Max. ⁽²⁾	Max.	Min.		
14	14	19.5	17	15 900	95 300
17.5	17.5	23.5	21	23 700	142 000
22.5	23	29.5	26	38 400	231 000
24.5	25.5	34.5	30	50 200	301 000
27.5	29	39.5	34	63 500	381 000
34.5	36	45.5	42	101 000	609 000
39.5	40	50.5	46.5	127 000	765 000
44	44	57.5	51.5	151 000	906 000
49.5	50.5	67.5	58	188 000	1 130 000
54.5	58.5	75.5	67	254 000	1 530 000
59.5	64.5	85.5	74.5	314 000	1 880 000
64.5	72.5	95.5	83.5	397 000	2 380 000
69.5	76	100.5	87	433 000	2 600 000
74.5	81.5	105.5	93	490 000	2 940 000
79.5	89.5	115.5	102	593 000	3 560 000
84.5	97.5	125.5	112	706 000	4 240 000
89.5	100.5	130.5	116	772 000	4 630 000
94.5	105.5	135.5	121	829 000	4 970 000
99.5	113.5	145.5	130	961 000	5 770 000
105.5	121.5	154.5	139	1 100 000	6 620 000

K

SB
GE
SBB

SPHERICAL BUSHINGS

Steel-on-steel Spherical Bushings



Shaft dia. 110 – 150mm

Shaft dia. mm	Identification number		Mass (Ref.) kg	Boundary dimensions mm						Permissible tilting angle degree α
				d	D	B	C	d_k	$r_{s\ min}^{(1)}$	
110	SB 110A	SB 11017093	8.55	110	170	93	80	160	1	5
115	SB 115A	SB 11518098	10.3	115	180	98	85	165	1	5
120	SB 120A	SB 120190105	12.4	120	190	105	90	175	1	5
130	SB 130A	SB 130200110	13.8	130	200	110	95	185	1	5
150	SB 150A	SB 150220120	17.0	150	220	120	105	205	1	5

Notes⁽¹⁾ Minimum allowable value of chamfer dimensions r_1 and r_2
⁽²⁾ When Spherical Bushings are used with full tilting angle, the shaft shoulder dimension must be less than the maximum value of d_a .
 Remarks1. The inner ring and the outer ring have an oil groove and two oil holes, respectively.
 2. No grease is prepacked. Perform proper lubrication.

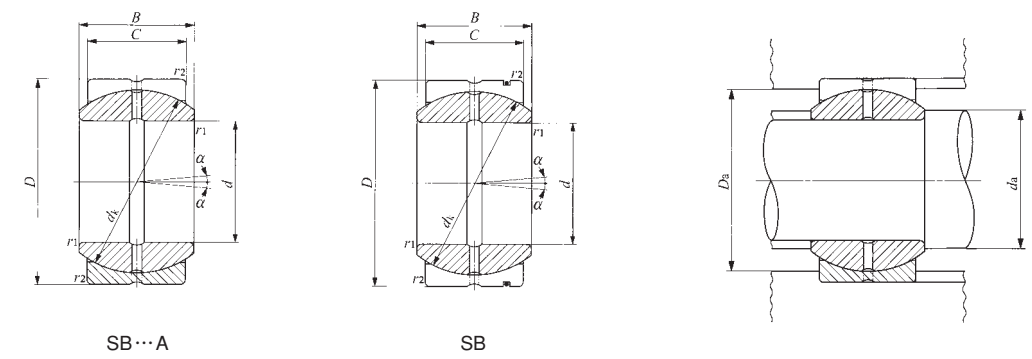

Mounting dimensions mm				Dynamic load capacity C_d N	Static load capacity C_s N
d_a		D_a			
Min.	Max. ⁽²⁾	Max.	Min.		
115.5	130	164.5	149	1 260 000	7 530 000
120.5	132.5	174.5	152	1 380 000	8 250 000
125.5	140	184.5	162	1 540 000	9 270 000
135.5	148.5	194.5	171	1 720 000	10 300 000
155.5	166	214.5	189	2 110 000	12 700 000

SPHERICAL BUSHINGS

Steel-on-steel Spherical Bushings

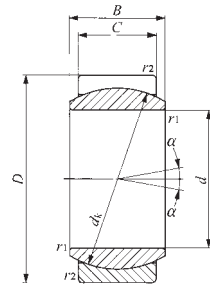

GE...E

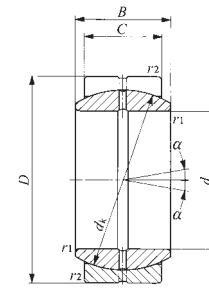

GE...ES

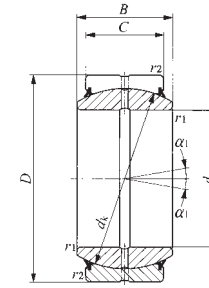

GE...ES-2RS

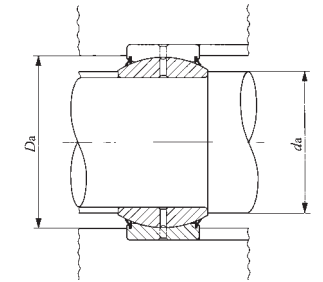

Shaft dia. 4 – 100mm

Shaft dia. mm	Identification number		Mass (Ref.) kg	Boundary dimensions mm							Permissible tilting angle degree	
	Without seals	With seals		d	D	B	C	d_k	$r_{1s \min}^{(1)}$	$r_{2s \min}^{(1)}$	α	α_1
4	GE 4E	—	0.003	4	12	5	3	8	0.3	0.3	16	—
5	GE 5E	—	0.004	5	14	6	4	10	0.3	0.3	13	—
6	GE 6E	—	0.004	6	14	6	4	10	0.3	0.3	13	—
8	GE 8E	—	0.008	8	16	8	5	13	0.3	0.3	15	—
10	GE 10E	—	0.012	10	19	9	6	16	0.3	0.3	12	—
12	GE 12E	—	0.017	12	22	10	7	18	0.3	0.3	11	—
15	GE 15ES	GE 15ES-2RS	0.032	15	26	12	9	22	0.3	0.3	8	5
17	GE 17ES	GE 17ES-2RS	0.049	17	30	14	10	25	0.3	0.3	10	7
20	GE 20ES	GE 20ES-2RS	0.065	20	35	16	12	29	0.3	0.3	9	6
25	GE 25ES	GE 25ES-2RS	0.115	25	42	20	16	35.5	0.6	0.6	7	4
30	GE 30ES	GE 30ES-2RS	0.160	30	47	22	18	40.7	0.6	0.6	6	4
35	GE 35ES	GE 35ES-2RS	0.258	35	55	25	20	47	0.6	1	6	4
40	GE 40ES	GE 40ES-2RS	0.315	40	62	28	22	53	0.6	1	7	4
45	GE 45ES	GE 45ES-2RS	0.413	45	68	32	25	60	0.6	1	7	4
50	GE 50ES	GE 50ES-2RS	0.560	50	75	35	28	66	0.6	1	6	4
60	GE 60ES	GE 60ES-2RS	1.10	60	90	44	36	80	1	1	6	3
70	GE 70ES	GE 70ES-2RS	1.54	70	105	49	40	92	1	1	6	4
80	GE 80ES	GE 80ES-2RS	2.29	80	120	55	45	105	1	1	6	4
90	GE 90ES	GE 90ES-2RS	2.82	90	130	60	50	115	1	1	5	3
100	GE 100ES	GE 100ES-2RS	4.43	100	150	70	55	130	1	1	7	5

Notes⁽¹⁾ Minimum allowable value of chamfer dimensions r_1 and r_2
⁽²⁾ When Spherical Bushings are used with full tilting angle, the shaft shoulder dimension must be less than the maximum value of d_a .
 Remarks1. GE...E has no oil hole. Others are provided with an oil groove and two oil holes on the inner ring and outer ring, respectively.
 2. No grease is prepacked. Perform proper lubrication.

Mounting dimensions mm				Dynamic load capacity C_d N	Static load capacity C_s N
d_a		D_a			
Min.	Max. ⁽²⁾	Max.	Min.		
6	6	9.5	8	2 350	14 100
7.5	8	11.5	10	3 920	23 500
8	8	11.5	10	3 920	23 500
10	10	13.5	13	6 370	38 200
12.5	13	16.5	15.5	9 410	56 500
14.5	15	19.5	17	12 400	74 100
17.5	18	23.5	22.5	19 400	117 000
19.5	20.5	27.5	26	24 500	147 000
22.5	24	32.5	30.5	34 100	205 000
29	29	37.5	37	55 700	334 000
34	34	42.5	41.5	71 800	431 000
39.5	39.5	49.5	48	92 200	553 000
44.5	45	56.5	54.5	114 000	686 000
49.5	50.5	62.5	60	147 000	883 000
54.5	56	69.5	66	181 000	1 090 000
65.5	66.5	84.5	79	282 000	1 690 000
75.5	77.5	99.5	91	361 000	2 170 000
85.5	89	114.5	103	463 000	2 780 000
95.5	98	124.5	112	564 000	3 380 000
105.5	109.5	144.5	127	701 000	4 210 000

SPHERICAL BUSHINGS

Steel-on-steel Spherical Bushings



Shaft dia. 110 – 300mm

Shaft dia. mm	Identification number		Mass (Ref.) kg	Boundary dimensions mm							Permissible tilting angle degree	
	Without seals	With seals		d	D	B	C	d_k	$r_{1s \min}^{(1)}$	$r_{2s \min}^{(1)}$	α	α_1
110	GE 110ES	GE 110ES-2RS	4.94	110	160	70	55	140	1	1	6	4
120	GE 120ES	GE 120ES-2RS	8.12	120	180	85	70	160	1	1	6	4
140	GE 140ES	GE 140ES-2RS	11.4	140	210	90	70	180	1	1	7	5
160	GE 160ES	GE 160ES-2RS	14.4	160	230	105	80	200	1	1	8	6
180	GE 180ES	GE 180ES-2RS	18.9	180	260	105	80	225	1.1	1.1	6	5
200	GE 200ES	GE 200ES-2RS	28.1	200	290	130	100	250	1.1	1.1	7	6
220	GE 220ES	GE 220ES-2RS	36.1	220	320	135	100	275	1.1	1.1	8	6
240	GE 240ES	GE 240ES-2RS	40.4	240	340	140	100	300	1.1	1.1	8	6
260	GE 260ES	GE 260ES-2RS	52.0	260	370	150	110	325	1.1	1.1	7	6
280	GE 280ES	GE 280ES-2RS	66.0	280	400	155	120	350	1.1	1.1	6	5
300	GE 300ES	GE 300ES-2RS	76.0	300	430	165	120	375	1.1	1.1	7	6

Notes⁽¹⁾ Minimum allowable value of chamfer dimensions r_1 and r_2
⁽²⁾ When Spherical Bushings are used with full tilting angle, the shaft shoulder dimension must be less than the maximum value of d_a .
 Remarks1. The inner ring and the outer ring have an oil groove and two oil holes, respectively.
 2. No grease is prepacked. Perform proper lubrication.

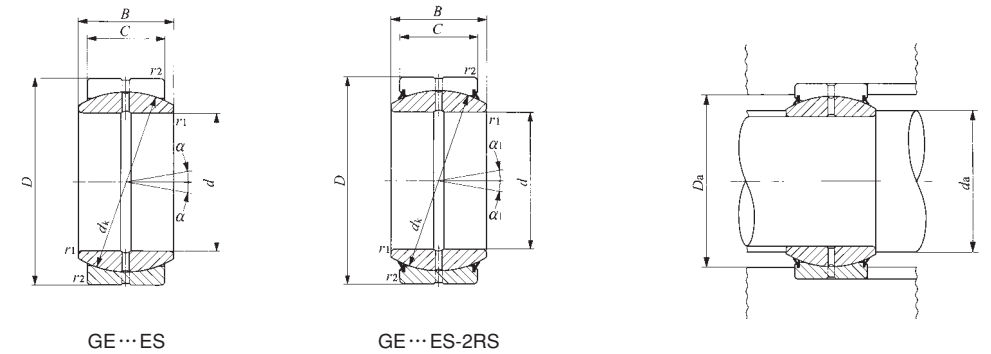

Mounting dimensions mm				Dynamic load capacity C_d N	Static load capacity C_s N
d_a		D_a			
Min.	Max. ⁽²⁾	Max.	Min.		
115.5	121	154.5	138	755 000	4 530 000
125.5	135.5	174.5	154	1 100 000	6 590 000
145.5	155.5	204.5	176	1 240 000	7 410 000
165.5	170	224.5	195	1 570 000	9 410 000
187	199	253	221	1 770 000	10 600 000
207	213.5	283	244	2 450 000	14 700 000
227	239.5	313	269	2 700 000	16 200 000
247	265	333	296	2 940 000	17 700 000
267	288	363	320	3 510 000	21 000 000
287	313.5	393	345	4 120 000	24 700 000
307	336.5	423	371	4 410 000	26 500 000

SPHERICAL BUSHINGS

Steel-on-steel Spherical Bushings

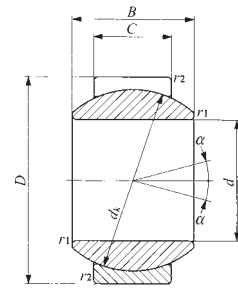

GE...G

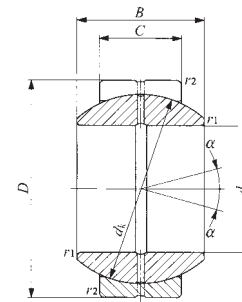

GE...GS

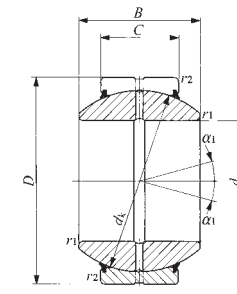

GE...GS-2RS

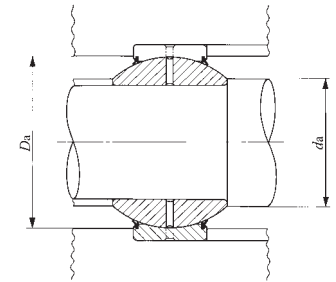

Shaft dia. 6 – 120mm

Shaft dia. mm	Identification number		Mass (Ref.) kg	Boundary dimensions mm							Permissible tilting angle degree	
	Without seals	With seals		d	D	B	C	dk	r _{1s} min ⁽¹⁾	r _{2s} min ⁽¹⁾	α	α ₁
6	GE 6G	—	0.010	6	16	9	5	13	0.3	0.3	21	—
8	GE 8G	—	0.015	8	19	11	6	16	0.3	0.3	21	—
10	GE 10G	—	0.022	10	22	12	7	18	0.3	0.3	18	—
12	GE 12G	—	0.041	12	26	15	9	22	0.3	0.3	18	—
15	GE 15GS	GE 15GS-2RS	0.059	15	30	16	10	25	0.3	0.3	16	13
17	GE 17GS	GE 17GS-2RS	0.083	17	35	20	12	29	0.3	0.3	19	16
20	GE 20GS	GE 20GS-2RS	0.155	20	42	25	16	35.5	0.3	0.6	17	16
25	GE 25GS	GE 25GS-2RS	0.215	25	47	28	18	40.7	0.6	0.6	17	15
30	GE 30GS	GE 30GS-2RS	0.330	30	55	32	20	47	0.6	1	17	16
35	GE 35GS	GE 35GS-2RS	0.400	35	62	35	22	53	0.6	1	16	15
40	GE 40GS	GE 40GS-2RS	0.515	40	68	40	25	60	0.6	1	17	14
45	GE 45GS	GE 45GS-2RS	0.660	45	75	43	28	66	0.6	1	15	13
50	GE 50GS	GE 50GS-2RS	1.50	50	90	56	36	80	0.6	1	17	16
60	GE 60GS	GE 60GS-2RS	2.05	60	105	63	40	92	1	1	17	15
70	GE 70GS	GE 70GS-2RS	3.00	70	120	70	45	105	1	1	16	14
80	GE 80GS	GE 80GS-2RS	3.60	80	130	75	50	115	1	1	14	13
90	GE 90GS	GE 90GS-2RS	5.41	90	150	85	55	130	1	1	15	14
100	GE 100GS	GE 100GS-2RS	6.15	100	160	85	55	140	1	1	14	12
110	GE 110GS	GE 110GS-2RS	9.70	110	180	100	70	160	1	1	12	11
120	GE 120GS	GE 120GS-2RS	15.5	120	210	115	70	180	1	1	16	15

Notes⁽¹⁾ Minimum allowable value of chamfer dimensions r_1 and r_2
⁽²⁾ When Spherical Bushings are used with full tilting angle, the shaft shoulder dimension must be less than the maximum value of d_a .
 Remarks1. GE...G has no oil hole. Others are provided with an oil groove and two oil holes on the inner ring and outer ring, respectively.
 2. No grease is prepacked. Perform proper lubrication.

Mounting dimensions mm				Dynamic load capacity C_d N	Static load capacity C_s N
d_a		D_a			
Min.	Max. ⁽²⁾	Max.	Min.		
8.5	9	13.5	13	6 370	38 200
10.5	11.5	16.5	15.5	9 410	56 500
12.5	13	19.5	17	12 400	74 100
14.5	16	23.5	21	19 400	117 000
17.5	19	27.5	26	24 500	147 000
19.5	21	32.5	30.5	34 100	205 000
22.5	25	37.5	37	55 700	334 000
29.5	29.5	42.5	41.5	71 800	431 000
34	34	49.5	48	92 200	553 000
39.5	39.5	56.5	54.5	114 000	686 000
44.5	44.5	62.5	60	147 000	883 000
49.5	50	69.5	66	181 000	1 090 000
54.5	57	84.5	79	282 000	1 690 000
65.5	67	99.5	91	361 000	2 170 000
75.5	78	114.5	103	463 000	2 780 000
85.5	87	124.5	112	564 000	3 380 000
95.5	98	144.5	127	701 000	4 210 000
105.5	111	154.5	138	755 000	4 530 000
115.5	124.5	174.5	154	1 100 000	6 590 000
125.5	138.5	204.5	176	1 240 000	7 410 000

SPHERICAL BUSHINGS

Steel-on-steel Spherical Bushings



Shaft dia. 140 – 280mm

Shaft dia. mm	Identification number		Mass (Ref.) kg	Boundary dimensions mm							Permissible tilting angle degree	
	Without seals	With seals		d	D	B	C	d_k	$r_{1s \min}^{(1)}$	$r_{2s \min}^{(1)}$	α	α_1
140	GE 140GS	GE 140GS-2RS	19.2	140	230	130	80	200	1	1	16	15
160	GE 160GS	GE 160GS-2RS	25.4	160	260	135	80	225	1	1.1	16	14
180	GE 180GS	GE 180GS-2RS	34.7	180	290	155	100	250	1.1	1.1	14	13
200	GE 200GS	GE 200GS-2RS	43.8	200	320	165	100	275	1.1	1.1	15	14
220	GE 220GS	GE 220GS-2RS	51.3	220	340	175	100	300	1.1	1.1	16	14
240	GE 240GS	GE 240GS-2RS	66.1	240	370	190	110	325	1.1	1.1	15	14
260	GE 260GS	GE 260GS-2RS	81.8	260	400	205	120	350	1.1	1.1	15	14
280	GE 280GS	GE 280GS-2RS	97.4	280	430	210	120	375	1.1	1.1	15	14

Notes⁽¹⁾ Minimum allowable value of chamfer dimensions r_1 and r_2
⁽²⁾ When Spherical Bushings are used with full tilting angle, the shaft shoulder dimension must be less than the maximum value of d_a .
 Remarks1. The inner ring and the outer ring have an oil groove and two oil holes, respectively.
 2. No grease is prepacked. Perform proper lubrication.

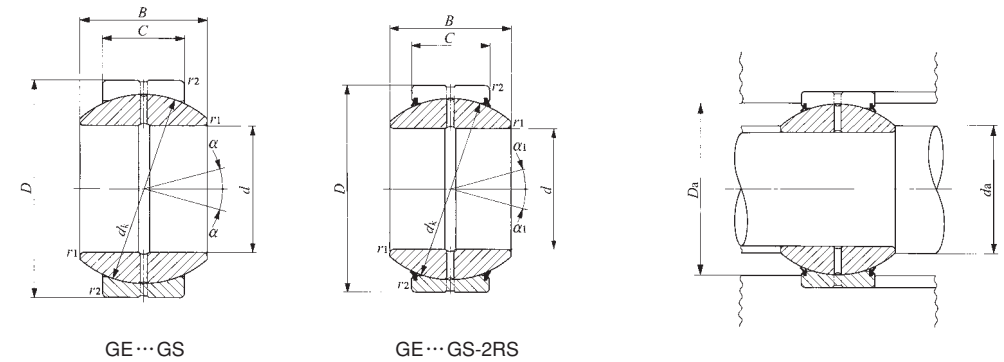

Mounting dimensions mm				Dynamic load capacity C_d N	Static load capacity C_s N
d_a		D_a			
Min.	Max. ⁽²⁾	Max.	Min.		
145.5	152	224.5	195	1 570 000	9 410 000
165.5	180	253	221	1 770 000	10 600 000
187	196	283	244	2 450 000	14 700 000
207	220	313	269	2 700 000	16 200 000
227	243.5	333	296	2 940 000	17 700 000
247	263.5	363	320	3 510 000	21 000 000
267	283.5	393	345	4 120 000	24 700 000
287	310.5	423	371	4 410 000	26 500 000

SPHERICAL BUSHINGS

Steel-on-steel Spherical Bushings **Inch Series**

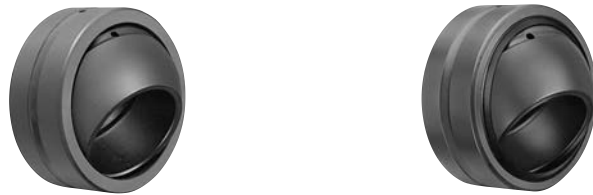

Shaft dia. 12.700 – 63.500mm

Shaft dia. mm (inch)	Identification number		Mass (Ref.) kg	Boundary dimensions mm(inch)			
	Without seal	With seals		<i>d</i>	<i>D</i>	<i>B</i>	<i>C</i>
12.700 (1/2)	SBB 8	—	0.020	12.700(1/2)	22.225(7/8)	11.10(.437)	9.52(.375)
15.875 (5/8)	SBB 10	—	0.036	15.875(5/8)	26.988(1 1/16)	13.89(.547)	11.91(.469)
19.050 (3/4)	SBB 12	SBB 12-2RS	0.057	19.050(3/4)	31.750(1 1/4)	16.66(.656)	14.27(.562)
22.225 (7/8)	SBB 14	SBB 14-2RS	0.088	22.225(7/8)	36.512(1 7/16)	19.43(.765)	16.66(.656)
25.400 (1)	SBB 16	SBB 16-2RS	0.125	25.400(1)	41.275(1 5/8)	22.22(.875)	19.05(.750)
31.750 (1 1/4)	SBB 20	SBB 20-2RS	0.234	31.750(1 1/4)	50.800(2)	27.76(1.093)	23.80(.937)
34.925 (1 3/8)	SBB 22	SBB 22-2RS	0.349	34.925(1 3/8)	55.562(2 1/16)	30.15(1.187)	26.19(1.031)
38.100 (1 1/2)	SBB 24	SBB 24-2RS	0.424	38.100(1 1/2)	61.912(2 3/16)	33.32(1.312)	28.58(1.125)
44.450 (1 3/4)	SBB 28	SBB 28-2RS	0.649	44.450(1 3/4)	71.438(2 13/16)	38.89(1.531)	33.32(1.312)
50.800 (2)	SBB 32	SBB 32-2RS	0.939	50.800(2)	80.962(3 1/16)	44.45(1.750)	38.10(1.500)
57.150 (2 1/4)	SBB 36	SBB 36-2RS	1.32	57.150(2 1/4)	90.488(3 3/16)	50.01(1.969)	42.85(1.687)
63.500 (2 1/2)	SBB 40	SBB 40-2RS	1.85	63.500(2 1/2)	100.012(3 15/16)	55.55(2.187)	47.62(1.875)

Note⁽¹⁾ Maximum allowable corner radius of the shaft or housing
 Remarks1. The value with mark * is applicable to types without seals. For types with seals, the value is 0.4 mm.
 2. The inner ring and the outer ring have an oil groove and two oil holes, respectively.
 3. No grease is prepacked. Perform proper lubrication.

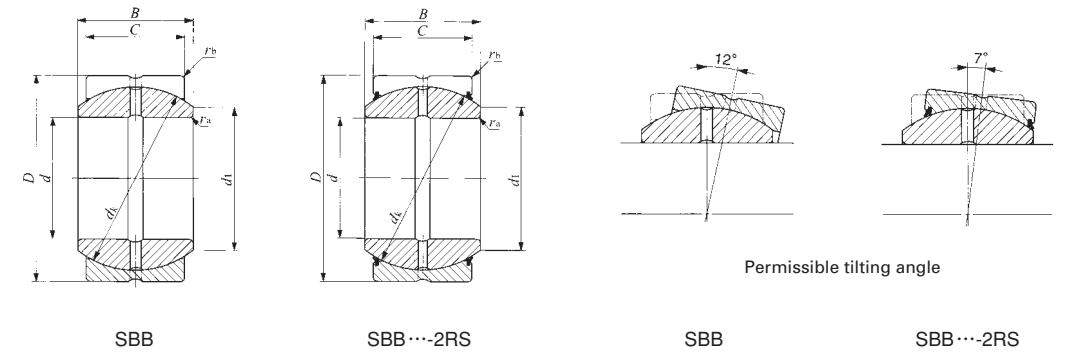

<i>d_k</i>	Radial internal clearance mm Min./Max.	Mounting dimensions mm			Dynamic load capacity <i>C_d</i> N	Static load capacity <i>C_s</i> N
		<i>d₁</i>	<i>r_{as}</i> ⁽¹⁾ Max.	<i>r_{bs}</i> ⁽¹⁾ Max.		
18 (.709)	0.05 / 0.15	14.0	0.2	0.6	16 800	101 000
23 (.906)	0.05 / 0.15	17.9	0.2	0.8	26 900	161 000
27.5(1.083)	0.08 / 0.18	21.4	0.6	*0.8	38 500	231 000
32 (1.260)	0.08 / 0.18	25.0	0.6	*0.8	52 300	314 000
36 (1.417)	0.08 / 0.18	28.0	0.6	*0.8	67 300	404 000
45 (1.772)	0.08 / 0.18	35.1	0.6	0.8	105 000	630 000
49 (1.929)	0.08 / 0.18	38.5	0.6	0.8	126 000	755 000
55 (2.165)	0.08 / 0.18	43.3	0.6	0.8	154 000	925 000
64 (2.520)	0.08 / 0.18	50.4	0.6	0.8	209 000	1 250 000
73 (2.874)	0.08 / 0.18	57.6	0.6	0.8	273 000	1 640 000
82 (3.228)	0.10 / 0.20	64.9	0.6	0.8	345 000	2 070 000
91 (3.583)	0.10 / 0.20	72.0	0.6	0.8	425 000	2 550 000

SPHERICAL BUSHINGS

Steel-on-steel Spherical Bushings **Inch Series**



Shaft dia. 69.850 – 152.400mm

Shaft dia. mm (inch)	Identification number		Mass (Ref.) kg	Boundary dimensions mm(inch)			
	Without seal	With seals		<i>d</i>	<i>D</i>	<i>B</i>	<i>C</i>
69.850 (2 3/4)	SBB 44	SBB 44-2RS	2.44	69.850 (2 3/4)	111.125 (4 3/8)	61.11 (2.406)	52.37 (2.062)
76.200 (3)	SBB 48	SBB 48-2RS	3.12	76.200 (3)	120.650 (4 3/4)	66.68 (2.625)	57.15 (2.250)
82.550 (3 1/4)	SBB 52	SBB 52-2RS	3.92	82.550 (3 1/4)	130.175 (5 1/8)	72.24 (2.844)	61.90 (2.437)
88.900 (3 1/2)	SBB 56	SBB 56-2RS	4.83	88.900 (3 1/2)	139.700 (5 1/2)	77.77 (3.062)	66.68 (2.625)
95.250 (3 3/4)	SBB 60	SBB 60-2RS	5.87	95.250 (3 3/4)	149.225 (5 7/8)	83.34 (3.281)	71.42 (2.812)
101.600 (4)	SBB 64	SBB 64-2RS	7.07	101.600 (4)	158.750 (6 1/4)	88.90 (3.500)	76.20 (3.000)
107.950 (4 1/4)	SBB 68	SBB 68-2RS	8.46	107.950 (4 1/4)	168.275 (6 5/8)	94.46 (3.719)	80.95 (3.187)
114.300 (4 1/2)	SBB 72	SBB 72-2RS	9.94	114.300 (4 1/2)	177.800 (7)	100.00 (3.937)	85.72 (3.375)
120.650 (4 3/4)	SBB 76	SBB 76-2RS	11.6	120.650 (4 3/4)	187.325 (7 3/8)	105.56 (4.156)	90.47 (3.562)
127.000 (5)	SBB 80	SBB 80-2RS	13.5	127.000 (5)	196.850 (7 3/4)	111.12 (4.375)	95.25 (3.750)
152.400 (6)	SBB 96	SBB 96-2RS	17.6	152.400 (6)	222.250 (8 3/4)	120.65 (4.750)	104.78 (4.125)

Note⁽¹⁾ Maximum allowable corner radius of the shaft or housing
 Remarks1. The inner ring and the outer ring have an oil groove and two oil holes, respectively.
 2. No grease is prepacked. Perform proper lubrication.

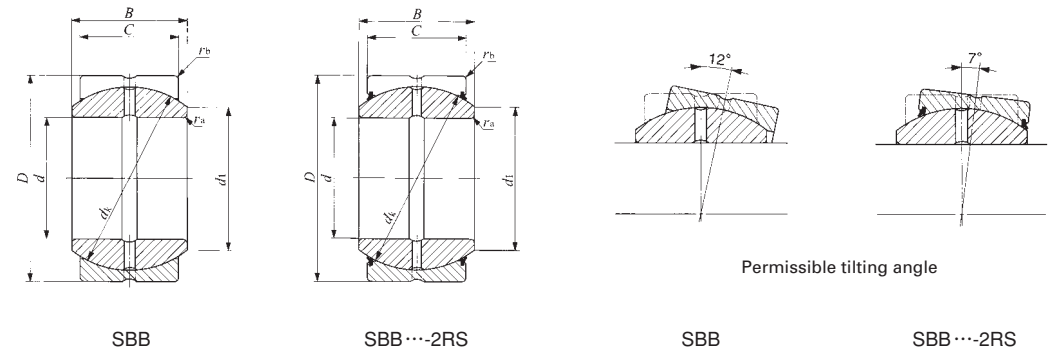

<i>d_k</i>	Radial internal clearance mm Min./Max.	Mounting dimensions mm			Dynamic load capacity <i>C_d</i> N	Static load capacity <i>C_s</i> N
		<i>d₁</i>	⁽¹⁾ <i>r_{as}</i> max Max.	⁽¹⁾ <i>r_{bs}</i> max Max.		
100(3.937)	0.10 / 0.20	79.0	0.6	0.8	514 000	3 080 000
110(4.331)	0.10 / 0.20	86.5	0.6	0.8	616 000	3 700 000
119(4.685)	0.13 / 0.23	94.1	0.6	0.8	722 000	4 330 000
128(5.039)	0.13 / 0.23	101.6	0.6	0.8	837 000	5 020 000
137(5.394)	0.13 / 0.23	108.4	0.6	0.8	960 000	5 760 000
146(5.748)	0.13 / 0.23	115.8	0.6	0.8	1 090 000	6 550 000
155(6.102)	0.13 / 0.23	122.6	0.8	1.1	1 230 000	7 380 000
164(6.457)	0.13 / 0.23	129.8	0.8	1.1	1 380 000	8 270 000
173(6.811)	0.13 / 0.23	136.8	0.8	1.1	1 530 000	9 210 000
183(7.205)	0.13 / 0.23	144.9	0.8	1.1	1 710 000	10 300 000
207(8.150)	0.13 / 0.23	167.5	0.8	1.1	2 130 000	12 800 000

SPHERICAL BUSHINGS

Maintenance-free Spherical Bushings



Shaft dia. 15 – 70mm

Shaft dia. mm	Identification number		Mass (Ref.) kg	Boundary dimensions mm							Permissible tilting angle degree	
	Without seals	With seals		d	D	B	C	d_k	$r_{1s \min}^{(1)}$	$r_{2s \min}^{(1)}$	α	α_1
15	GE 15EC	—	0.032	15	26	12	9	22	0.3	0.3	8	—
17	GE 17EC	—	0.049	17	30	14	10	25	0.3	0.3	10	—
20	GE 20EC	—	0.065	20	35	16	12	29	0.3	0.3	9	—
25	GE 25EC	—	0.115	25	42	20	16	35.5	0.6	0.6	7	—
30	GE 30EC	GE 30EC-2RS	0.160	30	47	22	18	40.7	0.6	0.6	6	4
35	—	GE 35EC-2RS	0.258	35	55	25	20	47	0.6	1	—	4
40	—	GE 40EC-2RS	0.315	40	62	28	22	53	0.6	1	—	4
45	—	GE 45EC-2RS	0.413	45	68	32	25	60	0.6	1	—	4
50	—	GE 50EC-2RS	0.560	50	75	35	28	66	0.6	1	—	4
60	—	GE 60EC-2RS	1.10	60	90	44	36	80	1	1	—	3
70	—	GE 70EC-2RS	1.54	70	105	49	40	92	1	1	—	4

Notes⁽¹⁾ Minimum allowable value of chamfer dimensions r_1 and r_2

⁽²⁾ When Spherical Bushings are used with full tilting angle, the shaft shoulder dimension must be less than the maximum value of d_a .

Remark No oil hole is provided.

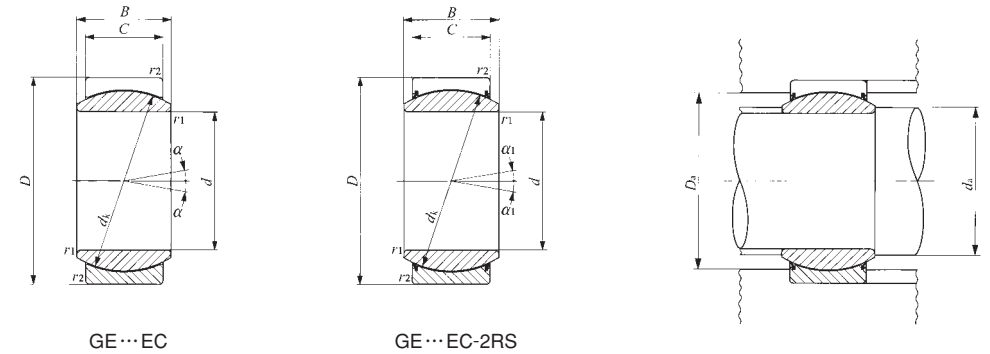

Mounting dimensions mm				Dynamic load capacity C_d N	Static load capacity C_s N
d_a		D_a			
Min.	Max. ⁽²⁾	Max.	Min.		
17.5	18	23.5	21.5	19 400	48 500
19.5	20.5	27.5	24.5	24 500	61 300
22.5	24	32.5	28	34 100	85 300
29	29	37.5	34	55 700	139 000
34	34	42.5	41.5	71 800	180 000
39.5	39.5	49.5	48	92 200	230 000
44.5	45	56.5	54.5	114 000	286 000
49.5	50.5	62.5	60	147 000	368 000
54.5	56	69.5	66	181 000	453 000
65.5	66.5	84.5	79	282 000	706 000
75.5	77.5	99.5	91	361 000	902 000