

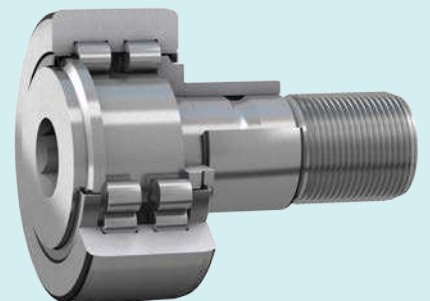

16

# Cam followers

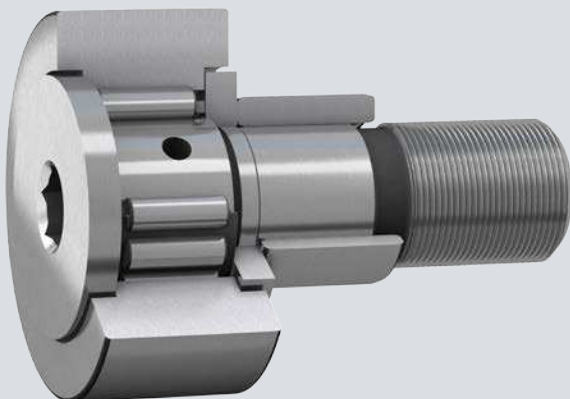

# 16 Cam followers



|   |            |
|---|------------|
| <b>Designs and variants</b> .....   | <b>965</b> |
| KR design cam followers .....   | 966        |
| NUKR .. A design cam followers .....  | 967        |
| PWKR ...2RS design cam followers .....  | 967        |
| Cages .....   | 968        |
| <b>Accessories</b> .....  | <b>968</b> |
| Grease fittings .....   | 968        |
| Hexagonal nuts .....  | 968        |
| VD1 plugs .....   | 968        |
| AP design adapters .....  | 968        |
| <b>Lubrication</b> .....  | <b>971</b> |
| <b>Bearing data</b> .....   | <b>972</b> |
| (Dimension standards, profile of the outer ring running surface, tolerances, internal clearance, defect frequencies)      |            |
| <b>Loads</b> .....  | <b>973</b> |
| (Dynamic loads, static loads, axial loads, minimum load, equivalent dynamic bearing load, equivalent static bearing load) |            |
| <b>Temperature limits</b> .....   | <b>974</b> |
| <b>Speed limits</b> .....   | <b>974</b> |
| <b>Design considerations</b> .....  | <b>974</b> |
| Attachment holes for studs .....  | 974        |
| Support surfaces .....  | 974        |
| <b>Mounting</b> .....   | <b>975</b> |
| <b>Designation system</b> .....   | <b>976</b> |
| <b>Product table</b>  |            |
| <b>16.1</b> Cam followers .....   | 978        |

# 16 Cam followers

## More information

|   |           |
|---|-----------|
| General bearing knowledge . . . . .         | 17        |
| <b>Bearing selection process . . . . .</b>  | <b>59</b> |
| Lubrication . . . . .                       | 109       |
| Bearing interfaces . . . . .                | 139       |
| Sealing, mounting and dismounting . . . . . | 193       |

SKF cam followers (stud-type track rollers) are designed to run on all types of tracks and to be used in cam drives, conveyor systems, etc.

SKF cam followers are based on either needle or cylindrical roller bearings. Instead of an inner ring, they have a threaded solid stud (pin).

SKF supplies them ready-to-mount. To meet the requirements of different applications, they are available in several designs and variants (**fig. 1**):

- with or without a cage
- with different stud designs:
  - a concentric seat
  - an eccentric collar
- with several sealing solutions
- with the outer ring running surface profile:
  - crowned as standard
  - cylindrical (flat)

In contrast to ball and roller bearings, where the bearing size refers to the bore diameter  $d$ , for cam followers the size refers to their outside diameter  $D$ .

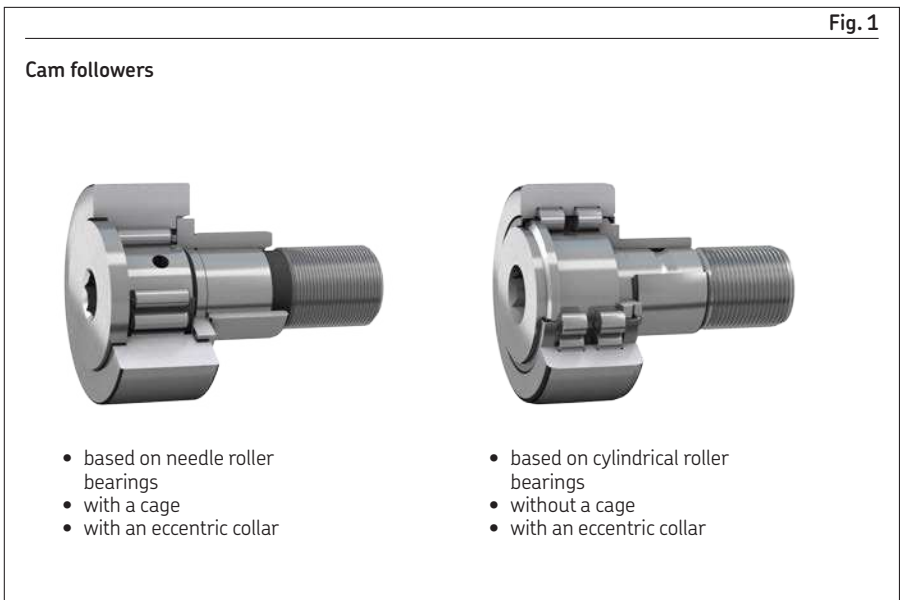

## Cam follower features

- Accommodate high radial loads**  
 The thick-walled outer ring enables high radial loads, while reducing distortion and bending stresses.
- Accommodate axial loads**  
 The flange rings enable cam followers to accommodate axial loads that can occur because of skew or tilting.
- Long service life**  
 The crowned outer ring running surface is beneficial for applications where outer ring tilting relative to the track may occur or where edge stresses need to be minimized.
- Easy to mount**  
 The threaded solid stud (pin) of cam followers can be quickly and easily attached to appropriate machine components by means of a hexagonal nut.

## Designs and variants

SKF cam followers have a thick-walled outer ring with its running surface crowned as standard. However, cam followers with a cylindrical (flat) running surface are also available (designation suffix X).

SKF cam followers are available in three basic designs (fig. 2):

- KR design
- NUKR design
- PWKR design

All three designs have the same main dimensions. They are available in different stud designs (fig. 3):

- a concentric seat
- an eccentric collar (E at the end of the basic designation) on the stud

The eccentric collar has a shrink-fit onto the stud, enabling less stringent positioning tolerances to be specified for associated components. The values of the adjustable eccentricity are listed in the [product table](#), [page 978](#).

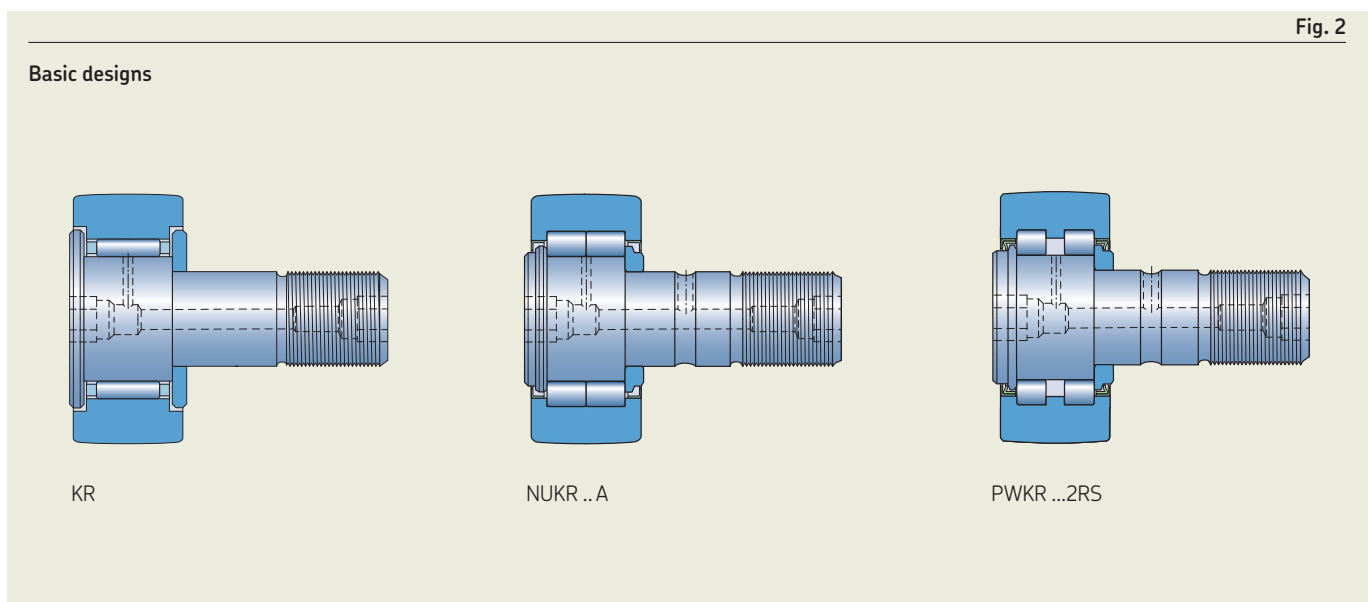
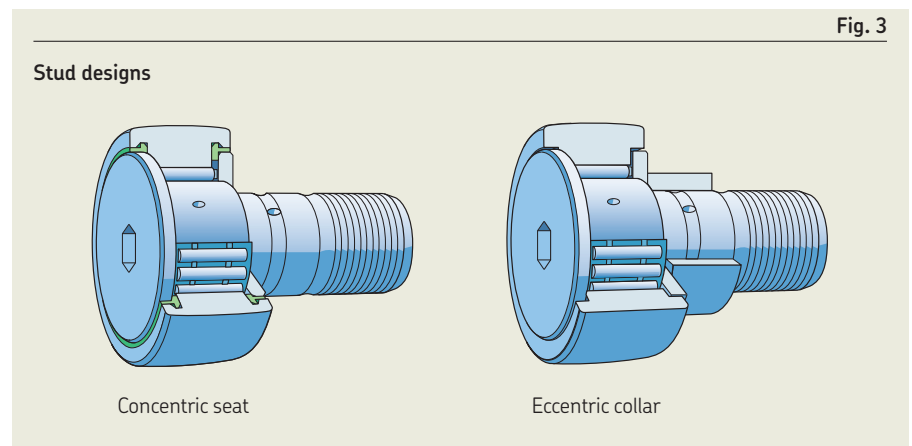

# KR design cam followers

- are available based on:
  - a needle roller and cage assembly (fig. 4)
  - a full complement needle roller set (fig. 5, V in the basic designation)  
 Cam followers based on a full complement of needle rollers accommodate higher loads than same-sized cam followers with a cage.
- have the outer ring axially guided by the pressed-on flange ring and the stud head (integral flange), forming a gap-type seal
- are also available with an axial sliding ring on both sides (designation suffixes PPA, fig. 6, or PPSKA, fig. 7, or PPXA):
  - made of PA66
  - forming narrow labyrinth seals with the outer ring in a radial direction, to protect against coarse contaminants
  - serving as contact seals in an axial direction to retain grease reliably in the bearing
  - improving lubrication conditions in the cam follower, keeping friction and frictional heat low, and extending grease life



## KR design cam followers, sizes 16 and 19

- without a designation suffix or with the designation suffix PPA (fig. 6)
  - have one slot in the head of the stud that enables the stud to be held in place by a screwdriver during mounting
  - have a relubrication hole for a press-in grease fitting or a plug if relubrication is not required in the centre of the slot (Accessories, page 968)
- with the designation suffix PPSKA (fig. 7)
  - have a hexagonal recess in the head of the stud that enables the stud to be held in place by a hexagonal key (Allen wrench) during mounting
  - have no relubrication features

## KR design cam followers, designation suffix B, sizes ≥ 22

- have a hexagonal recess at each end of the stud (fig. 4), enabling the cam follower to be held in place by a hexagonal key (Allen wrench) during mounting
- have a relubrication hole for a press-in grease fitting in the centre of each hexagonal recess
- can accommodate adapters from a centralized lubrication system for sizes ≥ 35 (Accessories, page 968)

Fig. 4

KR .. B design, sizes 22 and 26

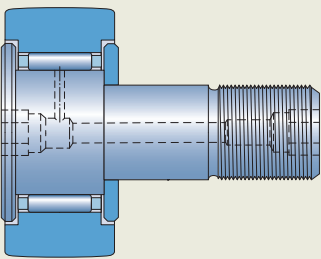

Fig. 5

KRV .. PPA design, sizes ≥ 30

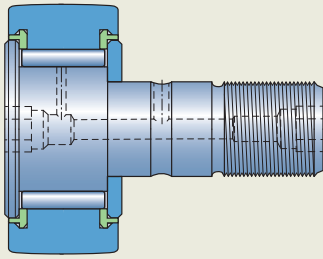
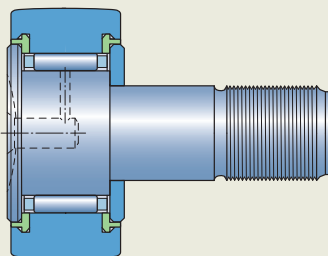
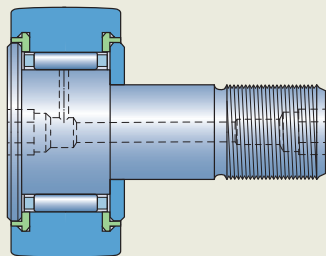

Fig. 6

KR .. PPA designs



Sizes 16 and 19



Sizes 22 and 26

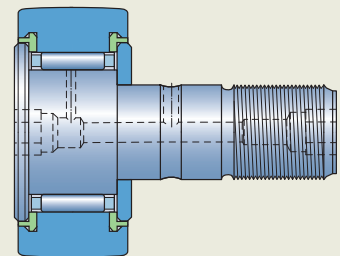

Sizes ≥ 30

## NUKR .. A design cam followers

- are based on double row full complement cylindrical roller bearings without an integral flange between the two roller sets (fig. 8)
- have the outer ring axially guided by the stud head and pressed-on flange ring via the roller sets
- have a sheet metal angle ring pressed into the outer ring shoulder on both sides, forming an effective labyrinth seal
- have a hexagonal recess at each end of the stud, enabling the cam follower to be held in place by a hexagonal key (Allen wrench) during mounting
- have a relubrication hole for a press-in grease fitting or an adapter from a centralized lubrication system in the centre of each hexagonal recess (Accessories, page 968)
- accommodate relatively heavy axial loads that can occur because of skew or tilting

## PWKR ...2RS design cam followers

- are based on double row full complement cylindrical roller bearings (fig. 9)
- have the outer ring axially guided by the stud head and pressed-on flange ring via the roller sets
- are fitted on both sides with an NBR contact seal, being integral with a sheet metal angle ring that is pressed into the outer ring shoulder, to press against the flange ring and the stud head
- have a hexagonal recess at each end of the stud, enabling the cam follower to be held in place by a hexagonal key (Allen wrench) during mounting
- have a relubrication hole for a press-in grease fitting or an adapter from a centralized lubrication system in the centre of each hexagonal recess (Accessories, page 968)
- accommodate relatively heavy axial loads that can occur because of skew or tilting

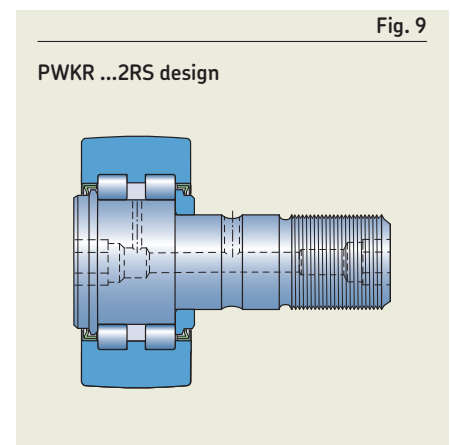
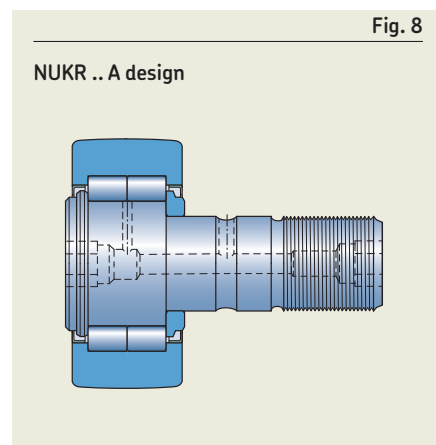
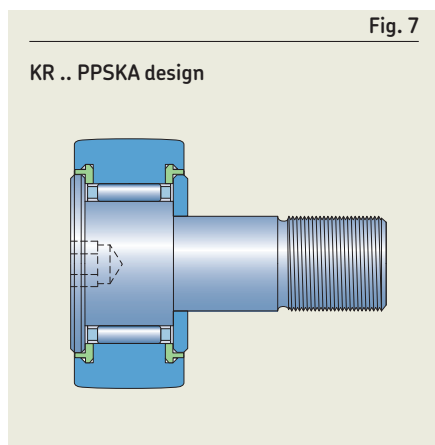

## Cages

Cam followers, if not a full complement of rollers, are fitted with a sheet steel window-type cage that is roller centred (fig. 10).

For information about the suitability of cages, refer to *Cages*, page 187.

## Accessories

SKF supplies accessories to enable reliable lubrication and location of SKF cam followers (table 1). Accessories, other than grease fittings and hexagonal nuts, must be ordered separately.

## Grease fittings

- are supplied with each cam follower as standard (table 1) and are the only ones to be used
- can be pressed into position
- are listed in table 2, page 970 with their dimensions
- have heads that protrude from the stud head end by 1,5 mm for KR design cam followers of sizes 16 and 19

## Hexagonal nuts

- are supplied with each cam follower as standard (table 1)
- are in accordance with ISO 4032 or ISO 8673
- are manufactured to strength class 8.8
- are zinc galvanized in accordance with ISO 4042
- are listed in table 3, page 970 with their dimensions and recommended tightening torques

## VD1 plugs

- are used to plug the relubrication hole end in the stud of KR design cam followers of sizes 16 and 19 without designation suffix PPSKA, where:
  - relubrication is not required
  - there is no space for the head of the grease fitting
- must be ordered separately (table 1)

## AP design adapters

- enable cam followers to be relubricated via a centralized lubrication system
- have a connection that accommodates, for example, 4 × 0,75 polyamide tubing in accordance with DIN 73378, as shown in fig. 11, in which:
  - 1 Connection
  - 2 O-ring
  - 3 Adapter connection
  - 4 Female thread M 10x1
  - 5 Polyamide tube
- must be ordered separately (table 1)
- are listed in table 4, page 970 with their dimensions

Fig. 10

Cage for cam follower

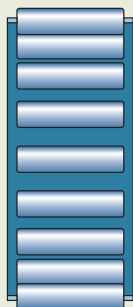

Fig. 11

Adapter for connection to centralized lubrication system

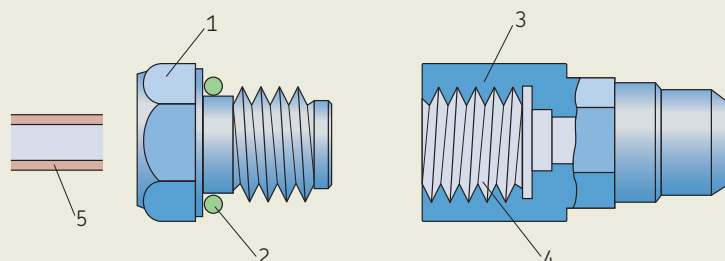
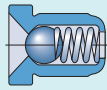

Table 1

## Accessories for cam followers



Grease fitting



Plug

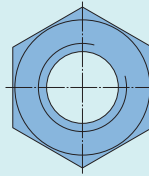

Hexagonal nut

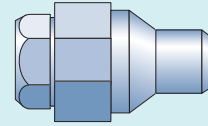

Adapter

| Cam follower<br>Design | Size             |               | Supplied with the cam follower |               | To be ordered separately |         |
|------------------------|------------------|---------------|--------------------------------|---------------|--------------------------|---------|
|                        | without<br>seals | with<br>seals | Grease fitting                 | Hexagonal nut | Plug                     | Adapter |
| KR                     | 16               | 16 PPA        | NIP A1                         | M 6x1         | VD1                      | –       |
| KRE                    | –                | 16 PPSKA      | –                              | M 6x1         | –                        | –       |
| KRV                    | 19               | 19 PPA        | NIP A1                         | M 8x1,25      | VD1                      | –       |
| –                      | –                | 19 PPSKA      | –                              | M 8x1,25      | –                        | –       |
| 22 B                   | –                | 22 PPA        | 2 x NIP A1x4,5                 | M 10x1        | –                        | –       |
| 26 B                   | –                | 26 PPA        | 2 x NIP A1x4,5                 | M 10x1        | –                        | –       |
| 30 B                   | –                | 30 PPA        | 2 x NIP A1x4,5                 | M 12x1,5      | –                        | –       |
| 32 B                   | –                | 32 PPA        | 2 x NIP A1x4,5                 | M 12x1,5      | –                        | –       |
| 35 B                   | –                | 35 PPA        | 2 x NIP A2x7,5                 | M 16x1,5      | –                        | AP 8    |
| 40 B                   | –                | 40 PPA        | 2 x NIP A2x7,5                 | M 18x1,5      | –                        | AP 8    |
| –                      | –                | 47 PPA        | 2 x NIP A2x7,5                 | M 20x1,5      | –                        | AP 10   |
| –                      | –                | 52 PPA        | 2 x NIP A2x7,5                 | M 20x1,5      | –                        | AP 10   |
| –                      | –                | 62 PPA        | 2 x NIP A3x9,5                 | M 24x1,5      | –                        | AP 14   |
| –                      | –                | 72 PPA        | 2 x NIP A3x9,5                 | M 24x1,5      | –                        | AP 14   |
| –                      | –                | 80 PPA        | 2 x NIP A3x9,5                 | M 30x1,5      | –                        | AP 14   |
| –                      | –                | 90 PPA        | 2 x NIP A3x9,5                 | M 30x1,5      | –                        | AP 14   |
| NUKR .. A              | –                | 35            | 2 x NIP A2x7,5                 | M 16x1,5      | –                        | AP 8    |
| NUKRE .. A             | –                | 40            | 2 x NIP A2x7,5                 | M 18x1,5      | –                        | AP 8    |
| PWKRE ...2RS           | –                | 47            | 2 x NIP A2x7,5                 | M 20x1,5      | –                        | AP 10   |
| PWKRE ...2RS           | –                | 52            | 2 x NIP A2x7,5                 | M 20x1,5      | –                        | AP 10   |
| –                      | –                | 62            | 2 x NIP A3x9,5                 | M 24x1,5      | –                        | AP 14   |
| –                      | –                | 72            | 2 x NIP A3x9,5                 | M 24x1,5      | –                        | AP 14   |
| –                      | –                | 80            | 2 x NIP A3x9,5                 | M 30x1,5      | –                        | AP 14   |
| –                      | –                | 90            | 2 x NIP A3x9,5                 | M 30x1,5      | –                        | AP 14   |





Table 2

Grease fittings

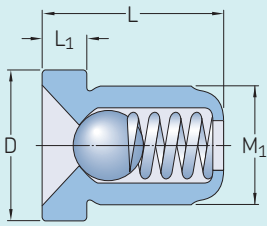

| Designation | Dimensions     |     |     |                |
|-------------|----------------|-----|-----|----------------|
|             | M <sub>1</sub> | D   | L   | L <sub>1</sub> |
| -           | mm             |     |     |                |
| NIP A1      | 4              | 6   | 6   | 1,5            |
| NIP A1x4,5  | 4              | 4,7 | 4,5 | 1              |
| NIP A2x7,5  | 6              | 7,5 | 7,5 | 2              |
| NIP A3x9,5  | 8              | 10  | 9,5 | 3              |

Table 3

Hexagonal nuts

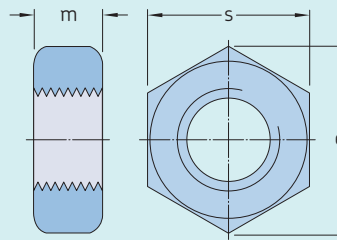

| Size     | Dimensions |      |    | Tightening torque | Standard <sup>1)</sup> |
|----------|------------|------|----|-------------------|------------------------|
|          | m          | e    | s  |                   |                        |
| -        | mm         |      |    | Nm                | -                      |
| M 6x1    | 5,2        | 11   | 10 | 3                 | 1                      |
| M 8x1,25 | 6,8        | 14,4 | 13 | 8                 | 1                      |
| M 10x1   | 8,4        | 17,8 | 16 | 15                | 2                      |
| M 12x1,5 | 10,8       | 20   | 18 | 22                | 2                      |
| M 16x1,5 | 14,8       | 26,8 | 24 | 58                | 2                      |
| M 18x1,5 | 15,8       | 29,6 | 27 | 87                | 2                      |
| M 20x1,5 | 18         | 33   | 30 | 120               | 2                      |
| M 24x1,5 | 21,5       | 39,5 | 36 | 220               | 2                      |
| M 30x1,5 | 25,6       | 50,9 | 46 | 450               | 2                      |

<sup>1)</sup> 1 = EN ISO 4032, ISO 4032  
 2 = EN ISO 8673, ISO 8673

Table 4

Dimensions of adapters for connecting to a centralized lubrication system

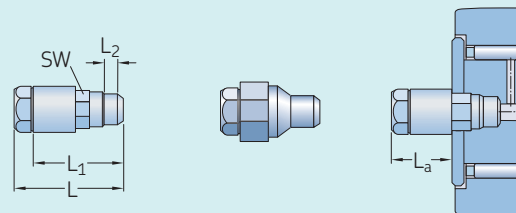

AP 8 and AP 10

AP 14

| Designation | Dimensions |                |                |                |    |
|-------------|------------|----------------|----------------|----------------|----|
|             | L          | L <sub>1</sub> | L <sub>2</sub> | L <sub>a</sub> | SW |
| -           | mm         |                |                |                |    |
| AP 8        | 27         | 22             | 4              | 16             | 8  |
| AP 10       | 27         | 22             | 5              | 15             | 10 |
| AP 14       | 25         | 20             | 6              | 8              | 14 |

# Lubrication

SKF cam followers are supplied greased ([table 1, page 933](#)).

For general information, refer to *Lubrication*, [page 109](#).

## Relubrication requirements

Cam followers:

- should be relubricated regularly to achieve their full service life, even if the initial grease fill still has its full lubricating properties
- used in applications where there are light loads, relatively low speeds and clean surroundings can operate for long periods before relubrication is required
- that operate under contaminated and damp conditions at high speeds or at temperatures  $> 70\text{ }^{\circ}\text{C}$  ( $160\text{ }^{\circ}\text{F}$ ) require more frequent relubrication
- without a cage (full complement of rollers) require more frequent relubrication

KR design cam followers of sizes 16 and 19 with designation suffix PPSKA cannot be relubricated.

## Relubrication features

Cam followers can be relubricated via ducts inside the stud. Depending on series and size, there are up to three positions for relubrication ([fig. 12](#)):

- Positions 1 and 2 can be fitted with the grease fitting supplied with the cam follower.
- Position 3 should be used when relubricating via ducts in the adjacent components.
- For detailed information about the positions, refer to [product tables, page 978](#).
- For cam followers, sizes  $\geq 35$ , positions 1 and 2 can be connected to a centralized lubrication system (*Accessories*, [page 968](#)).
- Positions not used for relubrication should be closed by a grease fitting or a plug (*Accessories*).

16



Fig. 12

### Cam follower relubrication points

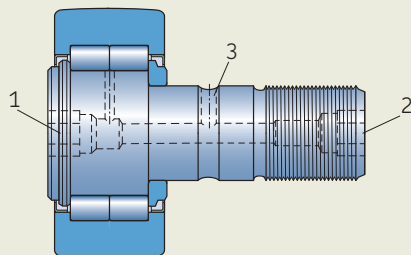

# Bearing data

|  |   |
|--|---|
| <b>Dimension standards</b>                       | ISO 7063 and ANSI/ABMA Standard 18.1 (where standardized)   |
| <b>Profile of the outer ring running surface</b> | <ul style="list-style-type: none"> <li>• <b>KR .. (B) designs</b><br/>Radius = 500 mm</li> <li>• <b>Other designs</b><br/>Improved crowned profile for better load distribution, higher stiffness and reduced wear</li> </ul>   |
| <b>Tolerances</b>                                | <p>Normal, except:</p> <ul style="list-style-type: none"> <li>• KR, KRE, KRV designs: ISO 7063</li> <li>• diameter of the crowned running surface: 0/-0,05 mm</li> <li>• stud shank diameter: h7</li> <li>• eccentric collar diameter: h9</li> </ul> <p>For additional information → <a href="#">page 35</a></p> <p>Values for Normal tolerance class: ISO 492 (<a href="#">table 2, page 38</a>)<br/>Values for ISO tolerance classes: h7 and h9 (<a href="#">table 2, page 970</a>)</p> |
| <b>Internal clearance</b>                        | <p>Between C2 and Normal</p> <p>For additional information → <a href="#">page 182</a></p> <p>Values: ISO 5753-1 (<a href="#">table 11, page 603</a>)<br/>Values are valid for unmounted bearings under zero measuring load.</p>   |
| <b>Defect frequencies</b>                        | → <a href="http://skf.com/bearingcalculator">skf.com/bearingcalculator</a>  |

# Loads

|   |  |   |
|---|--|---|
| <p><b>Dynamic loads</b></p>   | <p>As track rollers are not supported in a housing, the outer rings deform, leading to an altered load distribution and bending stresses in the outer ring.</p> <p>The basic load ratings listed in the <a href="#">product table, page 978</a>, take into account the altered load distribution, while the maximum radial loads <math>F_{r\max}</math> (<a href="#">product table</a>) are based on the bending stresses.</p> | <p><b>Symbols</b></p> <p><math>C_0</math> basic static load rating [kN] (<a href="#">product table, page 978</a>)</p> <p><math>F_r</math> radial load [kN]</p> <p><math>F_{r\max}</math> maximum permissible dynamic radial load [kN] (<a href="#">product table</a>)</p> <p><math>F_{0r\max}</math> maximum permissible static radial load [kN] (<a href="#">product table</a>)</p> <p><math>F_{rm}</math> minimum radial load [kN]</p> <p><math>P</math> equivalent dynamic bearing load [kN]</p> <p><math>P_0</math> equivalent static bearing load [kN]</p> |
| <p><b>Static loads</b></p>  | <p>Permissible static load is the lower value of <math>F_{0r\max}</math> or <math>C_0</math> (<a href="#">product table</a>).</p> <p>Where requirements for smooth running are below normal, the static load may exceed <math>C_0</math>, but should never exceed the maximum permissible static radial load <math>F_{0r\max}</math>.</p>  |   |
| <p><b>Axial loads</b></p>   | <p>Cam followers are intended for radial loads. However, their flange rings enable cam followers to accommodate axial loads that can occur because of skew or tilting. The magnitude of permissible load depends on the internal design.</p>   |   |
| <p><b>Minimum load</b></p> <p>For additional information → <a href="#">page 106</a></p>                   | <p><math>F_{rm} = 0,0167 C_0</math></p>  |   |
| <p><b>Equivalent dynamic bearing load</b></p> <p>For additional information → <a href="#">page 91</a></p> | <p><math>P = F_r</math></p>  |   |
| <p><b>Equivalent static bearing load</b></p> <p>For additional information → <a href="#">page 105</a></p> | <p><math>P_0 = F_r</math></p>  |   |

## Temperature limits

The permissible operating temperature for cam followers can be limited by:

- the dimensional stability of the bearing rings and rollers
- the cage
- the seals
- the lubricant

Where temperatures outside the permissible range are expected, contact SKF.

### Bearing rings and rollers

SKF cam followers are heat stabilized up to at least 140 °C (280 °F).

### Cages

Steel cages can be used at the same operating temperatures as the bearing rings and rollers.

### Seals

The permissible operating temperature for seals depends on the seal material:

- NBR: -40 to +100 °C (-40 to +210 °F)  
Temperatures up to 120 °C (250 °F) can be tolerated for brief periods.
- PA66 sliding rings: -30 to +100 °C (-20 to +210 °F)

Typically, temperature peaks are at the seal lip.

### Lubricants

Temperature limits for greases used in SKF cam rollers are provided in [table 1, page 933](#). For temperature limits of other SKF greases, refer to *Selecting a suitable SKF grease*, [page 116](#).

When using lubricants not supplied by SKF, temperature limits should be evaluated according to the SKF traffic light concept ([page 117](#)).

## Speed limits

The limiting speed listed in the [product table](#) is a mechanical limit that should not be exceeded unless the bearing design and the application are adapted for higher speeds.

For additional information, refer to *Operating temperature and speed*, [page 130](#).

## Design considerations

### Attachment holes for studs

The holes in the adjacent part of machinery that will accommodate the stud or eccentric collar of a cam follower should be machined to tolerance class H7 $\oplus$ .

If the requisite tightening torque for the hexagonal nut ([table 3, page 970](#)) cannot be achieved or the cam followers are subjected to peak loads, the stud or eccentric collar should be mounted with an interference fit. The lead-in chamfer of the holes should be  $\leq 0,5 \times 45^\circ$ .

## Support surfaces

The flange ring that is pressed onto the stud shank should be axially supported:

- over its entire side face ([fig. 13](#))
- according to diameter  $d_1$  ([product table, page 978](#))
- with material that has a sufficiently high strength to accommodate the tightening torque ([table 3, page 970](#))

Fig. 13

#### Supported flange ring

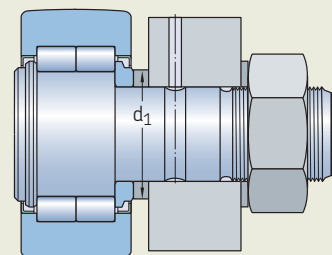

# Mounting

Cam followers can be attached to associated components (fig. 13) using the hexagonal nut (table 3, page 970) supplied with the cam follower. Spring washers, which are not supplied by SKF, serve to secure the nuts.

- To exploit the full load carrying capacity of cam followers, the nuts should be tightened to the recommended torque values (table 3).
- Where heavy vibrations occur, cam followers can be located using:
  - self-locking nuts in accordance with ISO 10511
  - special lock washers
 For self-locking nuts, a higher tightening torque must be applied. Follow the recommendations of the nut manufacturer.
- Cam followers, sizes  $\geq 22$ , have a hexagonal recess in the stud head and can be held in place by a hexagonal key (Allen wrench) while the nut is being tightened.
- Some small cam follower designs (sizes 16 and 19) have a slot in the stud head instead and can be held in place by a screwdriver. For additional information, refer to the illustrations in the product table, page 978.
- Depending on the mounting conditions, cam followers with an eccentric collar can be adjusted to the required eccentricity via the slot or the hexagonal recess.
- Do not hit the head of the stud as damage to the cam follower may result.
- SKF recommends positioning the lubrication hole in the stud head in the unloaded zone of the cam follower. The position of this hole corresponds to the SKF trademark on the head end of the stud.
- The lubrication hole in position 3 that is parallel and in line with the lubrication hole in the stud head (fig. 12, page 971) may be used to incorporate a locking device to prevent the stud from turning.
- When inserting a plug, it should be pressed into place using a mandrel (fig. 14).

Fig. 14

Inserting the VD1 plug with a mandrel

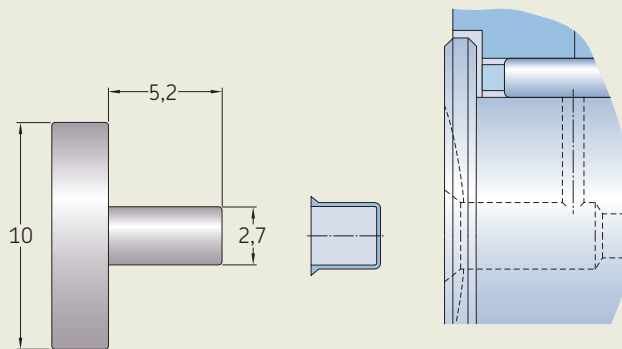

# Designation system



Prefixes

Basic designation

- KR** Cam follower fitted with a needle roller and cage assembly
- KRE** Cam follower fitted with a needle roller and cage assembly, with an eccentric collar pressed onto the stud
- KRV** Cam follower fitted with a full complement of needle rollers
- KRVE** Cam follower fitted with a full complement of needle rollers, with an eccentric collar pressed onto the stud
- NUKR** Cam follower based on a double row full complement cylindrical roller bearing with two integral outer ring flanges
- NUKRE** Cam follower based on a double row full complement cylindrical roller bearing with two integral outer ring flanges, with an eccentric collar pressed onto the stud
- PWKR** Cam follower based on a double row full complement cylindrical roller bearing with three integral outer ring flanges
- PWKRE** Cam follower based on a double row full complement cylindrical roller bearing with three integral outer ring flanges, with an eccentric collar pressed onto the stud

Suffixes

Group 1: Internal design

Group 2: External design (seals, snap ring groove, etc.)

- .2RS** NBR contact seal on both sides.
- A** Improved crowned profile of the outer ring running surface (NUTR design)
- B** Hexagonal recess on both ends of the stud
- PPA** KR design with a PA66 axial sliding and sealing ring on both sides; improved crowned profile of the outer ring running surface
  - Sizes 16 and 19 have one slot in the head of the stud as standard.
  - Sizes  $\geq 22$  have a hexagonal recess on both ends.
- PPSKA** KR design, sizes 16 and 19, with a PA66 axial sliding and sealing ring on both sides, improved crowned profile of the outer ring running surface and a hexagonal recess in the head of the stud, no relubrication features
- PPXA** PPA features except for the outer ring running surface, which has a cylindrical profile
- X** Cylindrical (flat) profile of the outer ring running surface
- XA** Cylindrical (flat) profile of the outer ring running surface (NUKR .. A or NUKRE .. A design)
- XB** Cylindrical (flat) profile of the outer ring running surface and a hexagonal recess on both ends of the stud (NUKR design)

Group 3: Cage design



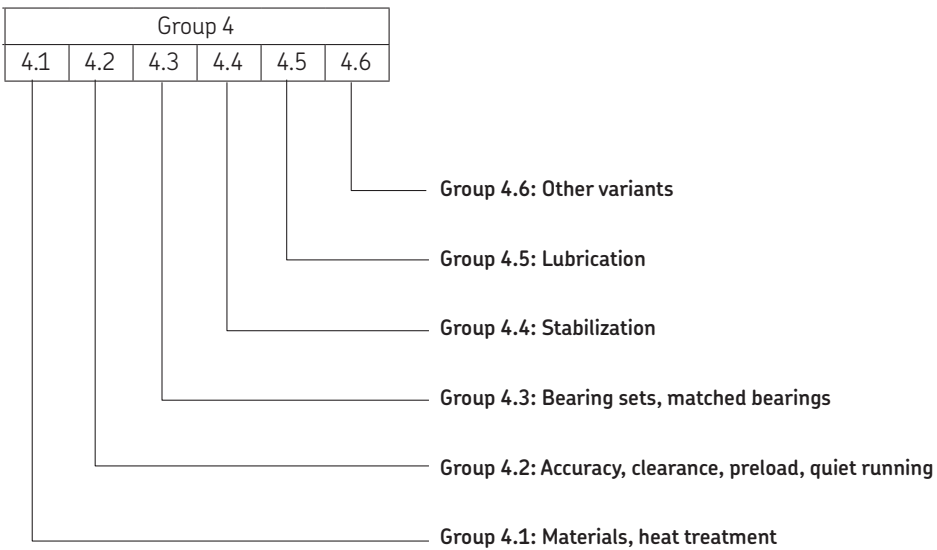



## 16.1 Cam followers

D 16 – 26 mm

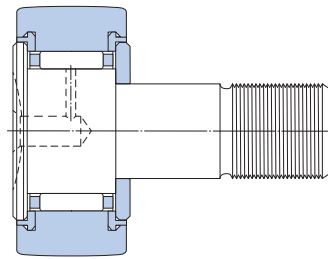
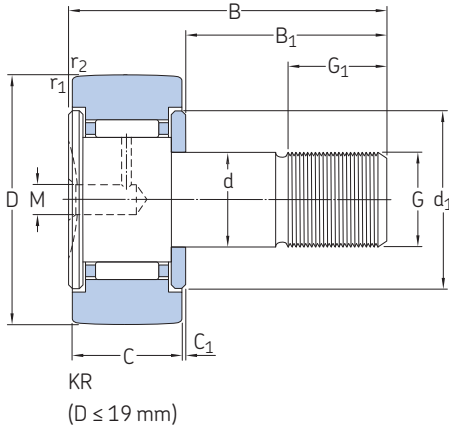

KR..PPA  
(D ≤ 19 mm)

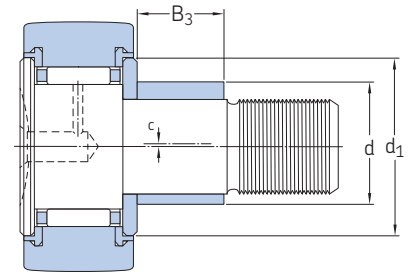

KRE..PPA  
(D ≤ 19 mm)

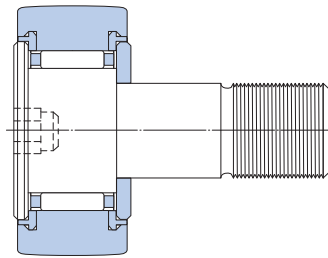

KR..PPSKA  
(D ≤ 19 mm)

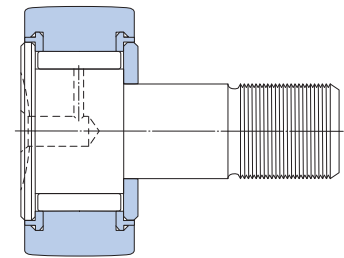

KRV..PPA  
(D ≤ 19 mm)

| Principal dimensions |    |    |    | Basic load ratings |                | Fatigue load limit | Maximum radial loads |                      | Limiting speed | Mass  | Designation   |
|----------------------|----|----|----|--------------------|----------------|--------------------|----------------------|----------------------|----------------|-------|---------------|
| D                    | d  | B  | C  | C                  | C <sub>0</sub> | P <sub>u</sub>     | F <sub>r</sub> max.  | F <sub>0r</sub> max. | r/min          | kg    | –             |
| mm                   |    |    |    | kN                 |                | kN                 | kN                   |                      |                |       |               |
| 16                   | 6  | 28 | 11 | 3,14               | 3,2            | 0,345              | 2,9                  | 4,15                 | 6 000          | 0,019 | ► KR 16       |
|                      | 6  | 28 | 11 | 3,14               | 3,2            | 0,345              | 2,9                  | 4,15                 | 6 000          | 0,018 | ► KR 16 PPA   |
|                      | 6  | 28 | 11 | 3,14               | 3,2            | 0,345              | 2,9                  | 4,15                 | 6 000          | 0,019 | ► KR 16 PPSKA |
|                      | 6  | 28 | 11 | 4,73               | 6,55           | 0,72               | 4,05                 | 5,7                  | 4 300          | 0,019 | ► KRV 16 PPA  |
|                      | 9  | 28 | 11 | 3,14               | 3,2            | 0,345              | 2,9                  | 4,15                 | 6 000          | 0,02  | ► KRE 16 PPA  |
| 19                   | 8  | 32 | 11 | 3,47               | 3,8            | 0,415              | 3,8                  | 5,5                  | 5 600          | 0,029 | ► KR 19       |
|                      | 8  | 32 | 11 | 3,47               | 3,8            | 0,415              | 3,8                  | 5,5                  | 5 600          | 0,029 | ► KR 19 PPA   |
|                      | 8  | 32 | 11 | 3,47               | 3,8            | 0,415              | 3,8                  | 5,5                  | 5 600          | 0,029 | ► KR 19 PPSKA |
|                      | 8  | 32 | 11 | 5,28               | 8              | 0,88               | 5,1                  | 7,35                 | 4 000          | 0,031 | ► KRV 19 PPA  |
|                      | 11 | 32 | 11 | 3,47               | 3,8            | 0,415              | 3,8                  | 5,5                  | 5 600          | 0,032 | ► KRE 19 PPA  |
| 22                   | 10 | 36 | 12 | 4,4                | 5              | 0,56               | 4,25                 | 6                    | 5 300          | 0,045 | ► KR 22 B     |
|                      | 10 | 36 | 12 | 4,4                | 5              | 0,56               | 4,25                 | 6                    | 5 300          | 0,043 | ► KR 22 PPA   |
|                      | 10 | 36 | 12 | 6,05               | 9,15           | 1,04               | 5,7                  | 8,15                 | 3 600          | 0,045 | ► KRV 22 PPA  |
|                      | 13 | 36 | 12 | 4,4                | 5              | 0,56               | 4,25                 | 6                    | 5 300          | 0,047 | ► KRE 22 PPA  |
| 26                   | 10 | 36 | 12 | 4,84               | 6              | 0,655              | 9,3                  | 13,2                 | 5 300          | 0,059 | ► KR 26 B     |
|                      | 10 | 36 | 12 | 4,84               | 6              | 0,655              | 9,3                  | 13,2                 | 5 300          | 0,057 | ► KR 26 PPA   |
|                      | 10 | 36 | 12 | 6,82               | 11             | 1,25               | 11,4                 | 16,3                 | 3 600          | 0,059 | ► KRV 26 PPA  |
|                      | 13 | 36 | 12 | 4,84               | 6              | 0,655              | 9,3                  | 13,2                 | 5 300          | 0,062 | ► KRE 26 PPA  |

► Popular item

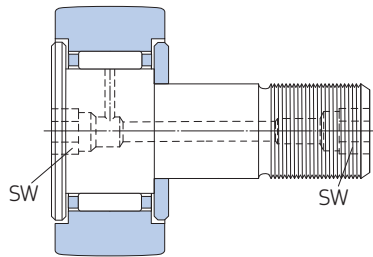

KR..B  
( $22 \leq D \leq 26$  mm)

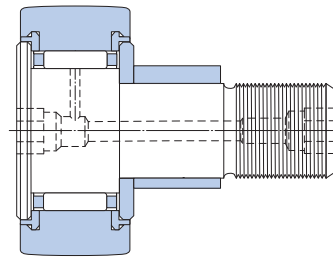

KRE..PPA  
( $22 \leq D \leq 26$  mm)

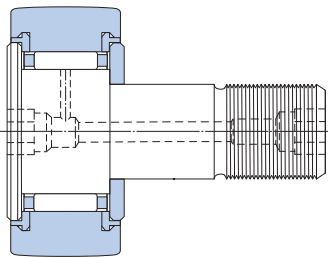

KR..PPA  
( $22 \leq D \leq 26$  mm)

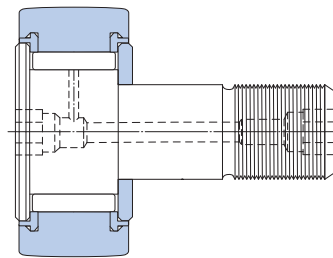

KRV..PPA  
( $22 \leq D \leq 26$  mm)

### Dimensions

| d  | B <sub>1</sub> | B <sub>2</sub> | B <sub>3</sub> | C <sub>1</sub> | d <sub>1</sub> | G      | G <sub>1</sub> | M | M <sub>1</sub> | SW | c   | r <sub>1,2</sub><br>min. |
|----|----------------|----------------|----------------|----------------|----------------|--------|----------------|---|----------------|----|-----|--------------------------|
| mm |                |                |                |                |                |        |                |   |                |    |     |                          |
| 16 | 16             | -              | -              | 0,6            | 12,5           | M 6    | 8              | 4 | -              | -  | -   | 0,15                     |
|    | 16             | -              | -              | 0,6            | 12,5           | M 6    | 8              | 4 | -              | -  | -   | 0,15                     |
|    | 16             | -              | -              | 0,6            | 12,5           | M 6    | 8              | - | -              | 4  | -   | 0,15                     |
| 16 | 16             | -              | -              | 0,6            | 12,5           | M 6    | 8              | 4 | -              | -  | -   | 0,15                     |
|    | 16             | -              | 7              | 0,6            | 12,5           | M 6    | 8              | 4 | -              | -  | 0,5 | 0,15                     |
|    | 16             | -              | -              | 0,6            | 12,5           | M 6    | 8              | 4 | -              | -  | -   | 0,15                     |
| 19 | 20             | -              | -              | 0,6            | 15             | M 8    | 10             | 4 | -              | -  | -   | 0,15                     |
|    | 20             | -              | -              | 0,6            | 15             | M 8    | 10             | 4 | -              | -  | -   | 0,15                     |
|    | 20             | -              | -              | 0,6            | 15             | M 8    | 10             | - | -              | 4  | -   | 0,15                     |
| 19 | 20             | -              | -              | 0,6            | 15             | M 8    | 10             | 4 | -              | -  | -   | 0,15                     |
|    | 20             | -              | 9              | 0,6            | 15             | M 8    | 10             | 4 | -              | -  | 0,5 | 0,15                     |
|    | 20             | -              | -              | 0,6            | 15             | M 8    | 10             | 4 | -              | -  | -   | 0,15                     |
| 22 | 23             | -              | -              | 0,6            | 17,5           | M 10x1 | 12             | 4 | -              | 5  | -   | 0,3                      |
|    | 23             | -              | -              | 0,6            | 17,5           | M 10x1 | 12             | 4 | -              | 5  | -   | 0,3                      |
|    | 23             | -              | -              | 0,6            | 17,5           | M 10x1 | 12             | 4 | -              | 5  | -   | 0,3                      |
| 22 | 23             | -              | 10             | 0,6            | 17,5           | M 10x1 | 12             | 4 | -              | 5  | 0,5 | 0,3                      |
|    | 23             | -              | -              | 0,6            | 17,5           | M 10x1 | 12             | 4 | -              | 5  | -   | 0,3                      |
|    | 23             | -              | -              | 0,6            | 17,5           | M 10x1 | 12             | 4 | -              | 5  | -   | 0,3                      |
| 26 | 23             | -              | 10             | 0,6            | 17,5           | M 10x1 | 12             | 4 | -              | 5  | 0,5 | 0,3                      |
|    | 23             | -              | -              | 0,6            | 17,5           | M 10x1 | 12             | 4 | -              | 5  | -   | 0,3                      |
|    | 23             | -              | -              | 0,6            | 17,5           | M 10x1 | 12             | 4 | -              | 5  | -   | 0,3                      |

## 16.1 Cam followers

D 30 – 35 mm

16.1

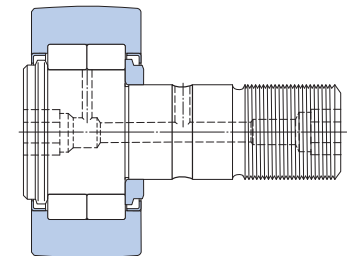
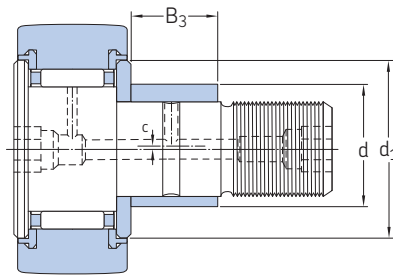
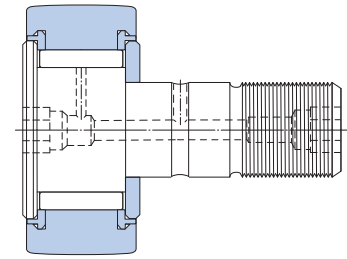
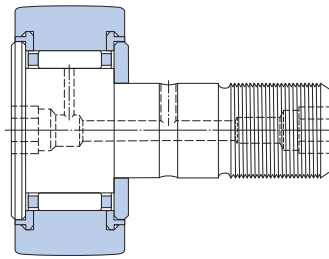
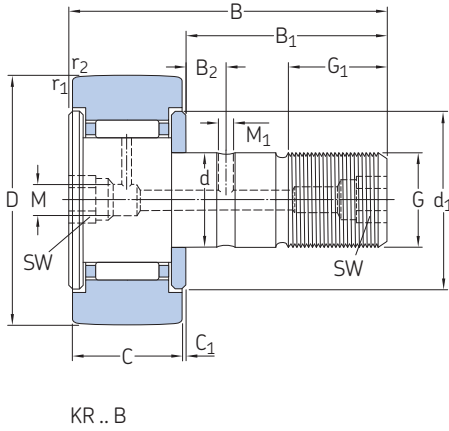

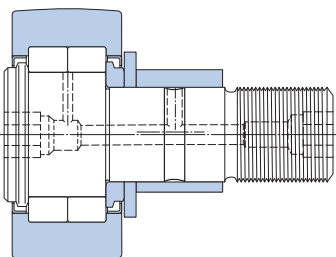

| Principal dimensions |    |    |    | Basic load ratings |                | Fatigue load limit | Maximum radial loads |                      | Limiting speed | Mass  | Designation   |
|----------------------|----|----|----|--------------------|----------------|--------------------|----------------------|----------------------|----------------|-------|---------------|
| D                    | d  | B  | C  | C                  | C <sub>0</sub> | P <sub>u</sub>     | F <sub>r</sub> max.  | F <sub>0r</sub> max. | r/min          | kg    | –             |
| mm                   |    |    |    | kN                 |                | kN                 | kN                   |                      |                |       |               |
| 30                   | 12 | 40 | 14 | 6,44               | 8              | 0,88               | 7,8                  | 11,2                 | 4 800          | 0,092 | ▶ KR 30 B     |
|                      | 12 | 40 | 14 | 6,44               | 8              | 0,88               | 7,8                  | 11,2                 | 4 800          | 0,088 | ▶ KR 30 PPA   |
|                      | 12 | 40 | 14 | 8,97               | 14,6           | 1,66               | 11                   | 15,6                 | 3 200          | 0,091 | ▶ KRV 30 PPA  |
|                      | 15 | 40 | 14 | 6,44               | 8              | 0,88               | 7,8                  | 11,2                 | 4 800          | 0,093 | ▶ KRE 30 PPA  |
| 32                   | 12 | 40 | 14 | 6,71               | 8,5            | 0,95               | 10,6                 | 15                   | 4 800          | 0,1   | ▶ KR 32 B     |
|                      | 12 | 40 | 14 | 6,71               | 8,5            | 0,95               | 10,6                 | 15                   | 4 800          | 0,098 | ▶ KR 32 PPA   |
|                      | 12 | 40 | 14 | 9,35               | 15,3           | 1,76               | 14,3                 | 20,4                 | 3 200          | 0,1   | ▶ KRV 32 PPA  |
|                      | 15 | 40 | 14 | 6,71               | 8,5            | 0,95               | 10,6                 | 15                   | 4 800          | 0,1   | ▶ KRE 32 PPA  |
| 35                   | 16 | 52 | 18 | 9,52               | 13,7           | 1,56               | 11,4                 | 16,3                 | 4 000          | 0,17  | ▶ KR 35 B     |
|                      | 16 | 52 | 18 | 9,52               | 13,7           | 1,56               | 11,4                 | 16,3                 | 4 000          | 0,16  | ▶ KR 35 PPA   |
|                      | 16 | 52 | 18 | 12,3               | 23,2           | 2,7                | 14,6                 | 20,8                 | 2 600          | 0,17  | ▶ KRV 35 PPA  |
|                      | 16 | 52 | 18 | 16,8               | 17,6           | 2                  | 8,65                 | 12,2                 | 5 000          | 0,16  | ▶ NUKR 35 A   |
|                      | 16 | 52 | 18 | 11,9               | 11,4           | 1,2                | 8,65                 | 12,5                 | 5 000          | 0,16  | ▶ PWKR 35.2RS |
|                      | 20 | 52 | 18 | 9,52               | 13,7           | 1,56               | 11,4                 | 16,3                 | 4 000          | 0,18  | ▶ KRE 35 PPA  |
|                      | 20 | 52 | 18 | 16,8               | 17,6           | 2                  | 8,65                 | 12,2                 | 5 000          | 0,18  | ▶ NUKRE 35 A  |

▶ Popular item

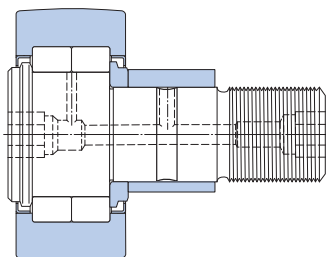

NUKRE ..A  
( $35 \leq D \leq 40$  mm)



NUKRE ..A  
( $D \geq 47$  mm)

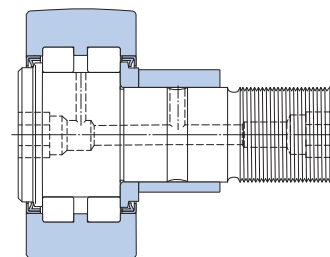

PWKR ...2RS

### Dimensions

| d  | B <sub>1</sub> | B <sub>2</sub> | B <sub>3</sub> | C <sub>1</sub> | d <sub>1</sub> | G       | G <sub>1</sub> | M | M <sub>1</sub> | SW | c   | r <sub>1,2</sub><br>min. |
|----|----------------|----------------|----------------|----------------|----------------|---------|----------------|---|----------------|----|-----|--------------------------|
| mm |                |                |                |                |                |         |                |   |                |    |     |                          |
| 30 | 25             | 6              | –              | 0,6            | 23             | M12x1,5 | 13             | 4 | 3              | 6  | –   | 0,6                      |
|    | 25             | 6              | –              | 0,6            | 23             | M12x1,5 | 13             | 4 | 3              | 6  | –   | 0,6                      |
|    | 25             | 6              | –              | 0,6            | 23             | M12x1,5 | 13             | 4 | 3              | 6  | –   | 0,6                      |
|    | 25             | 6              | 11             | 0,6            | 23             | M12x1,5 | 13             | 4 | 3              | 6  | 0,5 | 0,6                      |
| 32 | 25             | 6              | –              | 0,6            | 23             | M12x1,5 | 13             | 4 | 3              | 6  | –   | 0,6                      |
|    | 25             | 6              | –              | 0,6            | 23             | M12x1,5 | 13             | 4 | 3              | 6  | –   | 0,6                      |
|    | 25             | 6              | –              | 0,6            | 23             | M12x1,5 | 13             | 4 | 3              | 6  | –   | 0,6                      |
|    | 25             | 6              | 11             | 0,6            | 23             | M12x1,5 | 13             | 4 | 3              | 6  | 0,5 | 0,6                      |
| 35 | 32,5           | 8              | –              | 0,8            | 27,6           | M16x1,5 | 17             | 6 | 3              | 8  | –   | 0,6                      |
|    | 32,5           | 8              | –              | 0,8            | 27,6           | M16x1,5 | 17             | 6 | 3              | 8  | –   | 0,6                      |
|    | 32,5           | 8              | –              | 0,8            | 27,6           | M16x1,5 | 17             | 6 | 3              | 8  | –   | 0,6                      |
|    | 32,5           | 7,8            | –              | 0,8            | 20             | M16x1,5 | 17             | 6 | 3              | 8  | –   | 0,6                      |
|    | 32,5           | 7,8            | –              | 0,8            | 20             | M16x1,5 | 17             | 6 | 3              | 8  | –   | 0,6                      |
|    | 32,5           | 8              | 14             | 0,8            | 27,6           | M16x1,5 | 17             | 6 | 3              | 8  | 1   | 0,6                      |
|    | 29,5           | 7,8            | 12             | 3,8            | 27,6           | M16x1,5 | 17             | 6 | 3              | 8  | 1   | 0,6                      |

## 16.1 Cam followers

D 40 – 47 mm

16.1

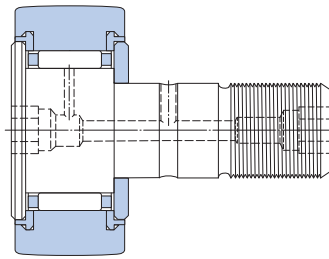
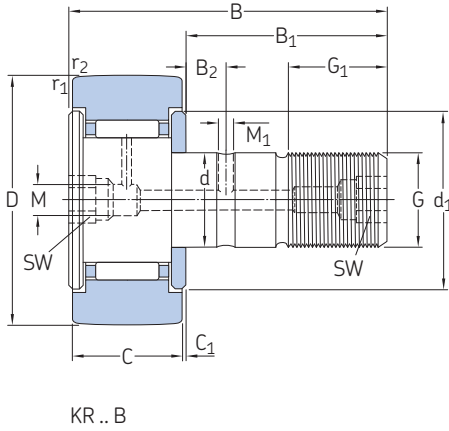
KR..PPA

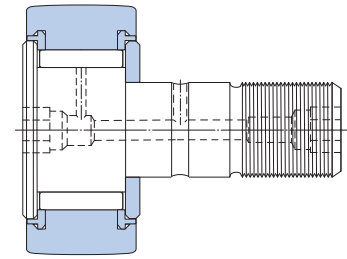

KRV..PPA

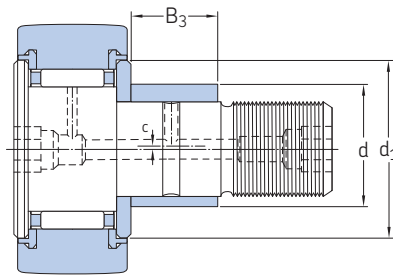

KRE..PPA

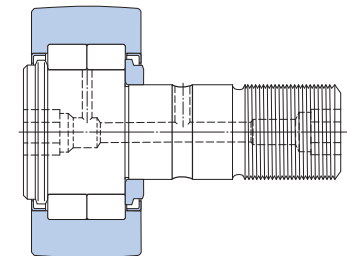

NUKR..A

| Principal dimensions |    |    |    | Basic load ratings |                | Fatigue load limit | Maximum radial loads |                      | Limiting speed | Mass | Designation   |
|----------------------|----|----|----|--------------------|----------------|--------------------|----------------------|----------------------|----------------|------|---------------|
| D                    | d  | B  | C  | C                  | C <sub>0</sub> | P <sub>u</sub>     | F <sub>r</sub> max.  | F <sub>0r</sub> max. |                |      |               |
| mm                   |    |    |    | kN                 |                | kN                 | kN                   |                      | r/min          | kg   | –             |
| 40                   | 18 | 58 | 20 | 10,5               | 14,6           | 1,73               | 12,5                 | 18                   | 3 400          | 0,25 | ► KR 40 B     |
|                      | 18 | 58 | 20 | 10,5               | 14,6           | 1,73               | 12,5                 | 18                   | 3 400          | 0,24 | ► KR 40 PPA   |
|                      | 18 | 58 | 20 | 14,2               | 26,5           | 3,1                | 17                   | 24,5                 | 2 200          | 0,25 | ► KRV 40 PPA  |
|                      | 18 | 58 | 20 | 19                 | 22             | 2,5                | 14                   | 20                   | 4 500          | 0,24 | ► NUKR 40 A   |
|                      | 18 | 58 | 20 | 13,8               | 14,3           | 1,5                | 13,7                 | 19,6                 | 4 500          | 0,24 | ► PWKR 40.2RS |
|                      | 22 | 58 | 20 | 10,5               | 14,6           | 1,73               | 12,5                 | 18                   | 3 400          | 0,26 | ► KRE 40 PPA  |
| 47                   | 22 | 58 | 20 | 19                 | 22             | 2,5                | 14                   | 20                   | 4 500          | 0,26 | ► NUKRE 40 A  |
|                      | 20 | 66 | 24 | 14,7               | 24,5           | 2,9                | 23,6                 | 33,5                 | 3 000          | 0,38 | ► KR 47 PPA   |
|                      | 20 | 66 | 24 | 19,4               | 41,5           | 5                  | 30,5                 | 43                   | 1 900          | 0,39 | ► KRV 47 PPA  |
|                      | 20 | 66 | 24 | 28,6               | 33,5           | 3,9                | 17,6                 | 25                   | 3 800          | 0,38 | ► NUKR 47 A   |
|                      | 20 | 66 | 24 | 22,9               | 24,5           | 2,8                | 18,3                 | 26                   | 3 800          | 0,38 | ► PWKR 47.2RS |
|                      | 24 | 66 | 24 | 14,7               | 24,5           | 2,9                | 23,6                 | 33,5                 | 3 000          | 0,4  | ► KRE 47 PPA  |
|                      | 24 | 66 | 24 | 28,6               | 33,5           | 3,9                | 17,6                 | 25                   | 3 800          | 0,4  | ► NUKRE 47 A  |

► Popular item

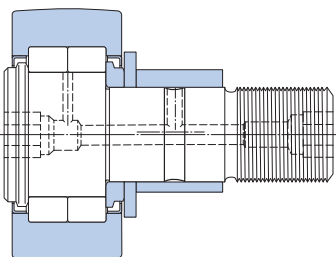

NUKRE ..A  
( $35 \leq D \leq 40$  mm)

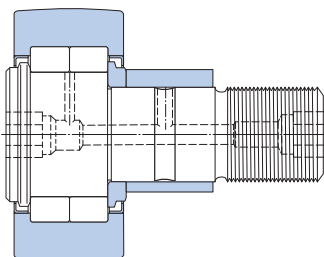

NUKRE ..A  
( $D \geq 47$  mm)

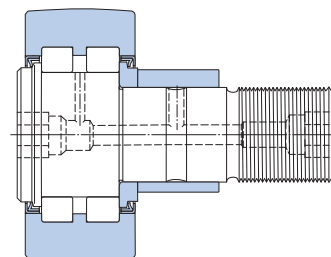

PWKR ...2RS

### Dimensions

| d  | B <sub>1</sub> | B <sub>2</sub> | B <sub>3</sub> | C <sub>1</sub> | d <sub>1</sub> | G       | G <sub>1</sub> | M | M <sub>1</sub> | SW | c | r <sub>1,2</sub><br>min. |
|----|----------------|----------------|----------------|----------------|----------------|---------|----------------|---|----------------|----|---|--------------------------|
| mm |                |                |                |                |                |         |                |   |                |    |   |                          |
| 40 | 36,5           | 8              | –              | 0,8            | 31,5           | M18x1,5 | 19             | 6 | 3              | 8  | – | 1                        |
|    | 36,5           | 8              | –              | 0,8            | 31,5           | M18x1,5 | 19             | 6 | 3              | 8  | – | 1                        |
|    | 36,5           | 8              | –              | 0,8            | 31,5           | M18x1,5 | 19             | 6 | 3              | 8  | – | 1                        |
|    | 36,5           | 8              | –              | 0,8            | 22             | M18x1,5 | 19             | 6 | 3              | 8  | – | 1                        |
|    | 36,5           | 8              | –              | 0,8            | 22             | M18x1,5 | 19             | 6 | 3              | 8  | – | 1                        |
|    | 36,5           | 8              | 16             | 0,8            | 31,5           | M18x1,5 | 19             | 6 | 3              | 8  | 1 | 1                        |
| 47 | 33,5           | 8              | 14             | 3,8            | 30             | M18x1,5 | 19             | 6 | 3              | 8  | 1 | 1                        |
|    | 40,5           | 9              | –              | 0,8            | 36,5           | M20x1,5 | 21             | 6 | 4              | 10 | – | 1                        |
|    | 40,5           | 9              | –              | 0,8            | 36,5           | M20x1,5 | 21             | 6 | 4              | 10 | – | 1                        |
|    | 40,5           | 9              | –              | 0,8            | 27             | M20x1,5 | 21             | 6 | 4              | 10 | – | 1                        |
|    | 40,5           | 9              | –              | 0,8            | 27             | M20x1,5 | 21             | 6 | 4              | 10 | – | 1                        |
|    | 40,5           | 9              | 18             | 0,8            | 36,5           | M20x1,5 | 21             | 6 | 4              | 10 | 1 | 1                        |
|    | 40,5           | 9              | 18             | 0,8            | 27             | M20x1,5 | 21             | 6 | 4              | 10 | 1 | 1                        |
|    | 40,5           | 9              | 18             | 0,8            | 27             | M20x1,5 | 21             | 6 | 4              | 10 | 1 | 1                        |

## 16.1 Cam followers

D 52 – 90 mm

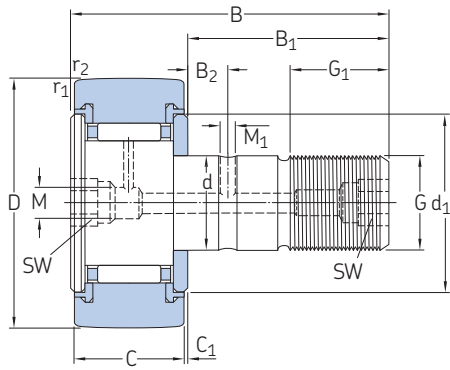

KR .. PPA

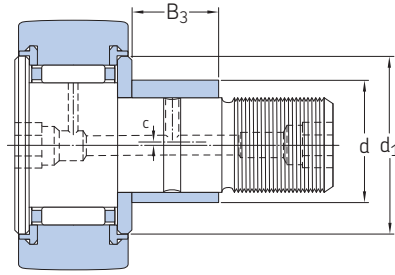

KRE .. PPA

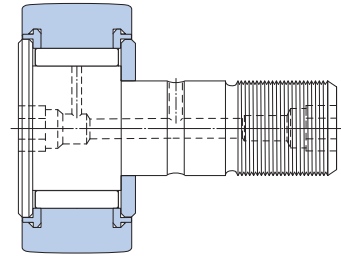

KRV .. PPA

| Principal dimensions |    |     |    | Basic load ratings |                | Fatigue load limit | Maximum radial loads |                      | Limiting speed | Mass | Designation                                   |
|----------------------|----|-----|----|--------------------|----------------|--------------------|----------------------|----------------------|----------------|------|---|
| D                    | d  | B   | C  | C                  | C <sub>0</sub> |                    | F <sub>r</sub> max.  | F <sub>0r</sub> max. |                |      |   |
| mm                   |    |     |    | kN                 |                | kN                 | kN                   |                      | r/min          | kg   | –   |
| 52                   | 20 | 66  | 24 | 15,7               | 27             | 3,2                | 36                   | 51                   | 3 000          | 0,45 | ▶ KR 52 PPA<br>▶ KRV 52 PPA<br>▶ NUKR 52 A    |
|                      | 20 | 66  | 24 | 20,9               | 46,5           | 5,6                | 45                   | 64                   | 1 900          | 0,46 |   |
|                      | 20 | 66  | 24 | 29,7               | 36             | 4,25               | 18                   | 25,5                 | 3 200          | 0,45 |   |
|                      | 20 | 66  | 24 | 23,8               | 26,5           | 3,05               | 18,6                 | 26,5                 | 3 200          | 0,45 | ▶ PWKR 52.2RS<br>▶ KRE 52 PPA<br>▶ NUKRE 52 A |
|                      | 24 | 66  | 24 | 15,7               | 27             | 3,2                | 36                   | 51                   | 3 000          | 0,47 |   |
|                      | 24 | 66  | 24 | 29,7               | 36             | 4,25               | 18                   | 25,5                 | 3 200          | 0,47 |   |
| 62                   | 24 | 80  | 29 | 24,6               | 44             | 5,5                | 58,5                 | 85                   | 2 400          | 0,77 | ▶ KR 62 PPA<br>▶ KRV 62 PPA<br>▶ NUKR 62 A    |
|                      | 24 | 80  | 29 | 31,4               | 72             | 9                  | 72                   | 102                  | 1 700          | 0,79 |   |
|                      | 24 | 80  | 28 | 41,3               | 48             | 5,85               | 25                   | 36                   | 2 600          | 0,8  |   |
|                      | 24 | 80  | 28 | 31,9               | 32,5           | 4,05               | 20,4                 | 29                   | 2 600          | 0,8  | ▶ PWKR 62.2RS<br>▶ KRE 62 PPA<br>▶ NUKRE 62 A |
|                      | 28 | 80  | 29 | 24,6               | 44             | 5,5                | 58,5                 | 85                   | 2 400          | 0,8  |   |
|                      | 28 | 80  | 28 | 41,3               | 48             | 5,85               | 25                   | 36                   | 2 600          | 0,82 |   |
| 72                   | 24 | 80  | 29 | 26                 | 48             | 6                  | 100                  | 143                  | 2 400          | 1    | ▶ KR 72 PPA<br>▶ KRV 72 PPA<br>▶ NUKR 72 A    |
|                      | 24 | 80  | 29 | 33                 | 80             | 9,8                | 118                  | 170                  | 1 700          | 1,05 |   |
|                      | 24 | 80  | 28 | 45,7               | 58,5           | 7,1                | 34,5                 | 50                   | 2 000          | 1    |   |
|                      | 24 | 80  | 28 | 39,6               | 45             | 5,6                | 47,5                 | 68                   | 2 600          | 1    | ▶ PWKR 72.2RS<br>▶ KRE 72 PPA<br>▶ NUKRE 72 A |
|                      | 28 | 80  | 29 | 26                 | 48             | 6                  | 100                  | 143                  | 2 400          | 1,05 |   |
|                      | 28 | 80  | 28 | 45,7               | 58,5           | 7,1                | 34,5                 | 50                   | 2 000          | 1,05 |   |
| 80                   | 30 | 100 | 35 | 36,9               | 72             | 9                  | 106                  | 150                  | 1 800          | 1,6  | ▶ KR 80 PPA<br>▶ KRV 80 PPA<br>▶ NUKR 80 A    |
|                      | 30 | 100 | 35 | 45,7               | 114            | 14                 | 122                  | 176                  | 1 400          | 1,65 |   |
|                      | 30 | 100 | 35 | 69,3               | 86,5           | 10,8               | 48                   | 69,5                 | 1 900          | 1,6  |   |
|                      | 30 | 100 | 35 | 57,2               | 73,5           | 9,3                | 64                   | 91,5                 | 2 000          | 1,6  | ▶ PWKR 80.2RS<br>▶ KRE 80 PPA<br>▶ NUKRE 80 A |
|                      | 35 | 100 | 35 | 36,9               | 72             | 9                  | 106                  | 150                  | 1 800          | 1,65 |   |
|                      | 35 | 100 | 35 | 69,3               | 86,5           | 10,8               | 48                   | 69,5                 | 1 900          | 1,65 |   |
| 90                   | 30 | 100 | 35 | 38                 | 76,5           | 9,5                | 160                  | 228                  | 1 800          | 2    | ▶ KR 90 PPA<br>▶ KRV 90 PPA<br>▶ NUKR 90 A    |
|                      | 30 | 100 | 35 | 47,3               | 122            | 15                 | 183                  | 260                  | 1 400          | 2    |   |
|                      | 30 | 100 | 35 | 78,1               | 102            | 12,7               | 86,5                 | 125                  | 1 900          | 1,95 |   |
|                      | 30 | 100 | 35 | 62,7               | 85             | 10,8               | 108                  | 153                  | 2 000          | 1,95 | ▶ PWKR 90.2RS<br>▶ KRE 90 PPA<br>▶ NUKRE 90 A |
|                      | 35 | 100 | 35 | 38                 | 76,5           | 9,5                | 160                  | 228                  | 1 800          | 2,05 |   |
|                      | 35 | 100 | 35 | 78,1               | 102            | 12,7               | 86,5                 | 125                  | 1 900          | 2    |   |

▶ Popular item

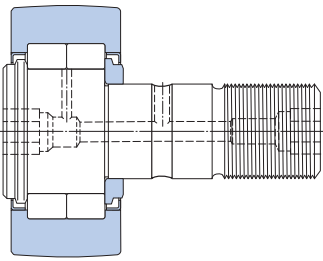

NUKR ..A

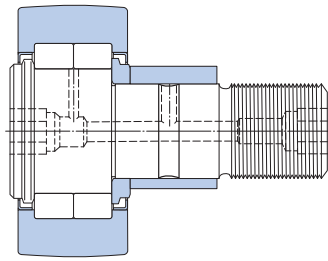

NUKRE ..A

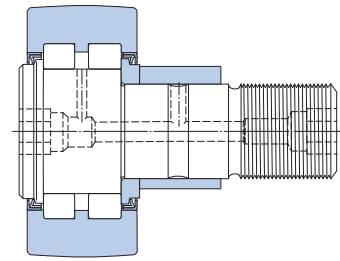

PWKR ...2RS

**Dimensions**

| d  | B <sub>1</sub> | B <sub>2</sub> | B <sub>3</sub> | C <sub>1</sub> | d <sub>1</sub> | G        | G <sub>1</sub> | M | M <sub>1</sub> | SW | c   | r <sub>1,2</sub><br>min. |
|----|----------------|----------------|----------------|----------------|----------------|----------|----------------|---|----------------|----|-----|--------------------------|
| mm |                |                |                |                |                |          |                |   |                |    |     |                          |
| 52 | 40,5           | 9              | –              | 0,8            | 36,5           | M 20x1,5 | 21             | 6 | 4              | 10 | –   | 1                        |
|    | 40,5           | 9              | –              | 0,8            | 36,5           | M 20x1,5 | 21             | 6 | 4              | 10 | –   | 1                        |
|    | 40,5           | 9              | –              | 0,8            | 31             | M 20x1,5 | 21             | 6 | 4              | 10 | –   | 1                        |
|    | 40,5           | 9              | –              | 0,8            | 31             | M 20x1,5 | 21             | 6 | 4              | 10 | –   | 1                        |
|    | 40,5           | 9              | 18             | 0,8            | 36,5           | M 20x1,5 | 21             | 6 | 4              | 10 | 1   | 1                        |
|    | 40,5           | 9              | 18             | 0,8            | 31             | M 20x1,5 | 21             | 6 | 4              | 10 | 1   | 1                        |
| 62 | 49,5           | 11             | –              | 0,8            | 44             | M 24x1,5 | 25             | 8 | 4              | 14 | –   | 1                        |
|    | 49,5           | 11             | –              | 0,8            | 44             | M 24x1,5 | 25             | 8 | 4              | 14 | –   | 1                        |
|    | 49,5           | 11             | –              | 1,3            | 38             | M 24x1,5 | 25             | 8 | 4              | 14 | –   | 1                        |
|    | 49,5           | 11             | –              | 1,3            | 38             | M 24x1,5 | 25             | 8 | 4              | 14 | –   | 1                        |
|    | 49,5           | 11             | 22             | 0,8            | 44             | M 24x1,5 | 25             | 8 | 4              | 14 | 1   | 1                        |
|    | 49,5           | 11             | 22             | 1,3            | 38             | M 24x1,5 | 25             | 8 | 4              | 14 | 1   | 1                        |
| 72 | 49,5           | 11             | –              | 0,8            | 44             | M 24x1,5 | 25             | 8 | 4              | 14 | –   | 1,1                      |
|    | 49,5           | 11             | –              | 0,8            | 44             | M 24x1,5 | 25             | 8 | 4              | 14 | –   | 1,1                      |
|    | 49,5           | 11             | –              | 1,3            | 44             | M 24x1,5 | 25             | 8 | 4              | 14 | –   | 1,1                      |
|    | 49,5           | 11             | –              | 1,3            | 44             | M 24x1,5 | 25             | 8 | 4              | 14 | –   | 1,1                      |
|    | 49,5           | 11             | 22             | 0,8            | 44             | M 24x1,5 | 25             | 8 | 4              | 14 | 1   | 1,1                      |
|    | 49,5           | 11             | 22             | 1,3            | 44             | M 24x1,5 | 25             | 8 | 4              | 14 | 1   | 1,1                      |
| 80 | 63             | 15             | –              | 1              | 53             | M 30x1,5 | 32             | 8 | 4              | 14 | –   | 1,1                      |
|    | 63             | 15             | –              | 1              | 53             | M 30x1,5 | 32             | 8 | 4              | 14 | –   | 1,1                      |
|    | 63             | 15             | –              | 1              | 47             | M 30x1,5 | 32             | 8 | 4              | 14 | –   | 1,1                      |
|    | 63             | 15             | –              | 1              | 47             | M 30x1,5 | 32             | 8 | 4              | 14 | –   | 1,1                      |
|    | 63             | 15             | 29             | 1              | 53             | M 30x1,5 | 32             | 8 | 4              | 14 | 1,5 | 1,1                      |
|    | 63             | 15             | 29             | 1              | 47             | M 30x1,5 | 32             | 8 | 4              | 14 | 1,5 | 1,1                      |
| 90 | 63             | 15             | –              | 1              | 53             | M 30x1,5 | 32             | 8 | 4              | 14 | –   | 1,1                      |
|    | 63             | 15             | –              | 1              | 53             | M 30x1,5 | 32             | 8 | 4              | 14 | –   | 1,1                      |
|    | 63             | 15             | –              | 1              | 47             | M 30x1,5 | 32             | 8 | 4              | 14 | –   | 1,1                      |
|    | 63             | 15             | –              | 1              | 47             | M 30x1,5 | 32             | 8 | 4              | 14 | –   | 1,1                      |
|    | 63             | 15             | 29             | 1              | 53             | M 30x1,5 | 32             | 8 | 4              | 14 | 1,5 | 1,1                      |
|    | 63             | 15             | 29             | 1              | 47             | M 30x1,5 | 32             | 8 | 4              | 14 | 1,5 | 1,1                      |

