

## WELD IN HUBS

Made from high quality C45 steel, weld in hubs are used to adapt pulleys, sprockets, platewheels, rotors, impellers, and many other devices, so that they can be firmly attached to a shaft.

The hubs are taper-bored, tapped and drilled, to receive standard taper-bore bushes.



## BOLT IN HUBS

Bolt in hubs perform a similar role as the previously described Weld In Hubs but, as the name suggests, the hub is secured to the device being secured to the shaft by bolts, rather than being welded.



**WELD IN HUB - DIAGRAM AND DIMENSIONS**

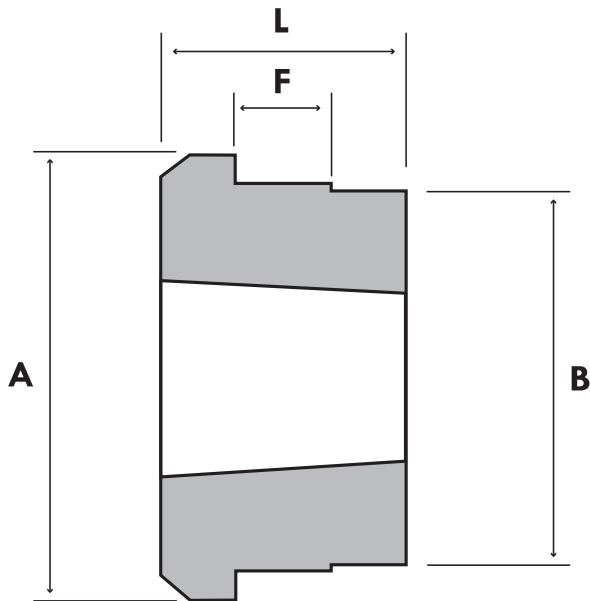

Hub Reference	Bush Size	A	B +0 -0,05	F	L
WH12	1210	70	65	10	25
WH16	1610	80	75	10	25
WH20	2012	95	90	12	32
WH25	2517	115	110	15	44
WH30	3020	145	140	15	50
WH35	3525	190	180	25	65
WH40	4030	200	190	30	76
WH45	4535	210	200	30	89
WH50	5040	230	220	35	102

**BOLT IN HUB - DIAGRAM AND DIMENSIONS**

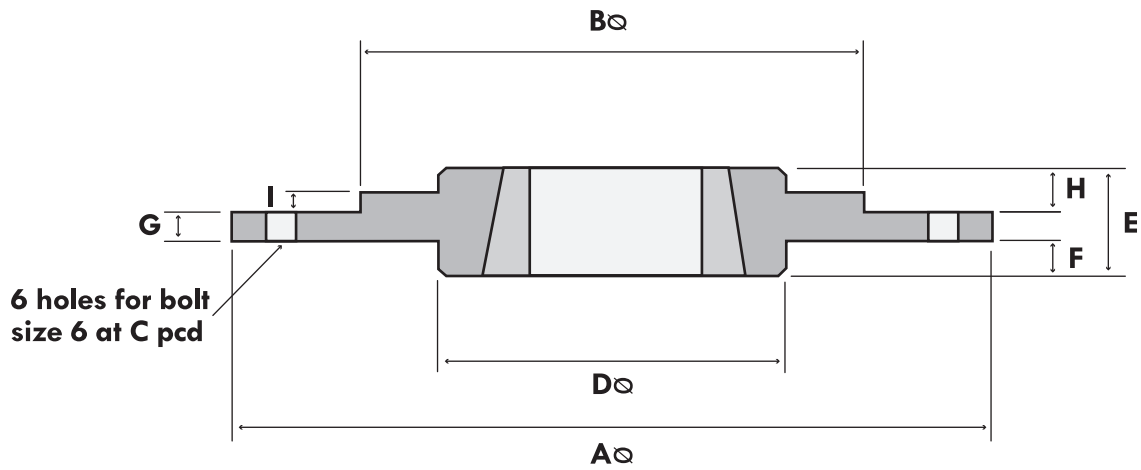

Hub Reference	Bush Size	Dimensions (mm)									
		A dia	B dia	C pcd	D dia	E nominal	F nominal	G nominal	H nominal	I nominal	J Clearance for
BF12	1210	120	N/A	100	80*	25	10	5.5	9.5	N/A	M6
BF16	1610	130	N/A	110	90*	25	10	6.5	8.5	N/A	M6
BF20	2012	145	N/A	125	100*	32	13	8.5	10.5	N/A	M8
BF25	2517	185	130*	155	120	44	20	11.5	12.5	2.5	M10
BF30	3020	220	165*	190	147	50	20	11.3	18.7	2.5	M12