

18

High temperature bearings



18 High temperature bearings

Deep groove ball bearings for high temperature applications	1008
Designs and variants	1008
Sealing solutions.	1008
Insert bearings for high temperature applications.	1010
Designs and variants	1010
Sealing solutions.	1011
Bearing data	1011
(Dimension standards, tolerances, radial internal clearance, permissible misalignment, stabilization)	
Loads and selecting bearing size	1012
Design considerations	1013
Location of bearings	1013
Operating environment	1013
Axial displacement	1013
Relubrication and running in.	1014
Mounting	1014
Designation system	1014
Product tables	
18.1 Single row deep groove ball bearings for high temperature applications.	1016
18.2 Insert bearings for high temperature applications, metric shafts	1020
18.3 Insert bearings for high temperature applications, inch shafts	1021

18 High temperature bearings

More information

General bearing knowledge	17
Bearing selection process	59
Bearing interfaces	139
Seat tolerances for standard conditions	148
Sealing, mounting and dismounting	193

Mounting instructions for individual bearings → skf.com/mount

SKF bearing maintenance handbook ISBN 978-91-978966-4-1

SKF high temperature bearings are designed to deliver increased reliability, reduced complexity and decreased environmental impact in operating temperatures up to 350 °C (660 °F). Because SKF high temperature bearings correspond to the ISO dimensions of grease-lubricated bearings, production efficiencies and cost savings can be realized with a simple change to the SKF bearing solution.

The environmental benefits of SKF high temperature bearings are so significant in many applications that they are included in the “SKF Beyond Zero” product portfolio.

Bearing benefits and features

- **Reduced total operating cost**
The bearings are designed to maintain the radial clearance needed for high temperature operation and so will not seize, even

when they cool rapidly, and therefore provide a long service life.

- **Excellent performance under severe conditions:**
 - hot conditions
 - dry environments
 - low rotational speeds
- **Reduced environmental impact**
- **Reduced machine design complexity**

Additionally, the benefits and features of high temperature bearings include (fig. 1):

1 No need for relubrication

All variants, except open (without shields) VA201 deep groove ball bearings, are lubricated for the life of the bearing with graphite-based high temperature lubricants. Open VA201 bearings require relubrication (*Relubrication and running in*, page 1014).

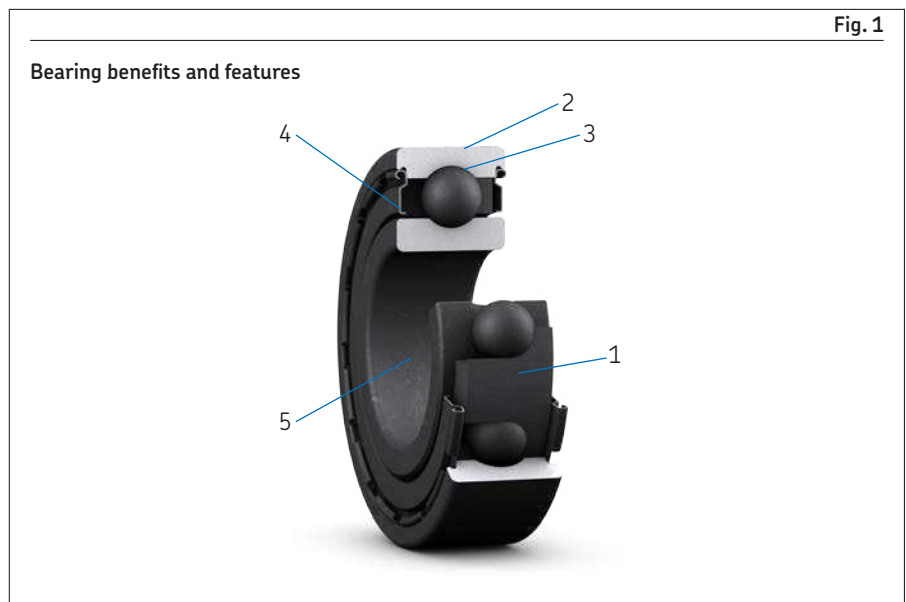

Fig. 1

Bearing benefits and features

2 Simple replacement

The boundary dimensions are the same as those of standard bearings.

3 Operating temperature up to 350 °C (660 °F)

The internal radial clearance and the lubricant are optimized for operation at high temperatures.

4 Protection against solid contamination

- Shields (designation suffix 2Z) protect the deep groove ball bearing.
- Shields and flingers (designation suffix 2F) protect the insert bearing.

5 Improved running in

The entire bearing surface is manganese phosphate coated.

Lubrication solutions

SKF high temperature bearing designs and variants incorporate various graphite-based lubrication solutions, including:

- lubricating paste composed of a poly-alkylene glycol/graphite mixture
- graphite cages (segmented or coronet)

For an overview of lubricant types, and other characteristics, for high temperature deep groove ball bearings and insert bearings, refer to [table 1, page 1009](#), and [table 2, page 1010](#).

During operation, the graphite maintains a very thin film on the bearing's raceways and rolling elements to reduce wear significantly. Graphite ages at a much higher temperature than oil and grease, and therefore does not lose its lubricating properties at the high temperatures at which it is recommended for use, so the need for relubrication is eliminated.

With many variants, all surfaces of the bearing and, where applicable, shields and flingers are manganese phosphate coated to enhance adhesion of the lubricant to the metal and provide some protection against corrosion.

Typical applications

- metals industry (cooling beds, roller tables, furnaces)
- food and beverage industry (continuous baking ovens, wafer baking ovens)
- automotive industry (paint lines, heat treatment ovens)
- glass industry (glass tableware or flat glass manufacturing processes)
- construction industry (tiles, mineral wool manufacturing)

Assortment

The SKF standard assortment of high temperature bearings and bearing units corresponding to ISO standards includes:

- Deep groove ball bearings ([fig. 2](#))
- Insert bearings (Y-bearings, [fig. 3](#))
- Ball bearing units ([fig. 4](#), skf.com/go/17000-18)
 - Zinc chromate plummer block units
 - Zinc chromate square flanged units
 - Zinc chromate oval flanged units

The assortment includes variants that contain food-grade lubricants registered by NSF as category H1 (lubricant acceptable with incidental food contact, for use in and around food processing areas). The NSF registration confirms the lubricant fulfils the requirements listed in the US Food and Drug Administration's guidelines under 21 CFR section 178.3570.

Customized bearings

In addition to high temperature bearings corresponding to ISO standards, SKF offers an assortment of customized high temperature bearings ([fig. 5, page 1008](#)).

These bearings are customized for use in applications such as:

- automatic wafer baking ovens in the food and beverage industry
- industrial furnaces
- chains

For additional information, contact SKF.

Fig. 2

Deep groove ball bearing



Fig. 3

Insert bearing



Fig. 4

Ball bearing unit



Deep groove ball bearings for high temperature applications

SKF deep groove ball bearings for high temperature applications correspond in design to standard single row deep groove ball bearings of the same size. They have no filling slots and can accommodate axial loads in addition to radial loads (*Loads and selecting bearing size*, [page 1012](#)).

The entire surface of the bearing and shields are manganese phosphate coated to enhance adhesion of the lubricant to the metal and improve the running-in properties of the bearing.

The radial internal clearance is a multiple of C5 to prevent the bearings from seizing, even when they cool rapidly.

Designs and variants

The SKF assortment of deep groove ball bearings for high temperature applications ([fig. 6](#)) provides solutions for various combinations of operating temperature and speed.

The lubrication type, maximum operating temperature, limiting speed, maintenance requirements and all other primary characteristics of the variants within the assortment are listed in [table 1](#).

Sealing solutions

High temperature deep groove ball bearings can be protected from contamination by either integrated shields, external shields or a combination of both.

For high temperature bearings, metallic shields are the primary recommendation where a capping device with low complexity is required. The shields:

- prevent the ingress of solid contaminants into the bearing
- are non-contacting
- generate no friction
- do not wear
- are particularly well suited for high temperatures because of their material and design

Integrated shields

High temperature deep groove ball bearings with designation suffix 2Z have integrated shields, but the VA201 variant is also available as an open bearing ([fig. 6](#)).

External shields

In some cases, integrated shields are insufficient and additional external shields should be considered, such as:

- Nilos rings ([fig. 7](#))
- SKF sealing washers ([fig. 8](#))

For additional information about sealing solutions, refer to *External sealing*, [page 194](#), and *Seals* (skf.com/seals).

NOTE: Because of the large radial clearance for high temperature deep groove ball bearings, special attention should be given to the design of the sealing arrangement.

Custom-made seals

In cases where neither integrated nor external shields are applicable, SKF can provide custom-made seals for operating temperatures up to 250 °C (480 °F). These seals are usually made of PTFE (polytetrafluoroethylene) thermoplastics.

To further improve sealing systems that incorporate custom-made seals, it is preferable to use a wear sleeve such as the *SKF Speedi-Sleeve* (skf.com/seals). This improves the seal counterface condition without the need for re-machining. For additional information, contact SKF.

Fig. 5

Customized deep groove ball bearings



⚠ WARNING

PTFE seals exposed to an open flame or temperatures above 300 °C (570 °F) are a health and environmental hazard! They remain dangerous even after they have cooled.

Read and follow the safety precautions on [page 197](#).

Fig. 6

High temperature deep groove ball bearing variants

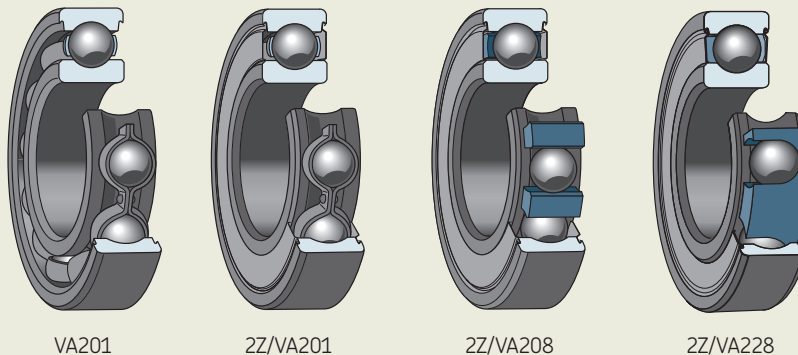

Table 1

Characteristics of high temperature variants for deep groove ball bearings

Characteristics	VA201, 2Z/VA201	2Z/VA208	2Z/VA228
Lubrication type	Polyalkylene glycol/graphite mixture	Segmented cage made of graphite	Coronet cage made of graphite
Phosphated rings, rolling elements and cages	✓	✓	✓
NSF H1 food grade	✗	✓	✓
Shields (suffix 2Z)	optional	✓	✓
Relubrication-free	2Z variant	✓	✓
Maximum operating temperature	250 °C (480 °F)	350 °C (660 °F)	350 °C (660 °F)
Limiting speed [r/min] ¹⁾	4 500 / d _m	4 500 / d _m	9 000 / d _m

¹⁾ d_m = bearing mean diameter = 0,5 (d + D). For outer ring rotation, use d_m = D.

Fig. 7

Nilos ring

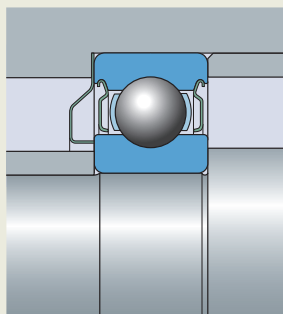
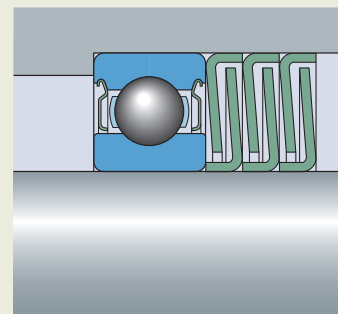

Fig. 8

SKF sealing washers



Insert bearings for high temperature applications

Except for the cage and seals, SKF insert bearings (Y-bearings) for high temperature applications correspond in design to standard insert bearings with grub screws in the YAR 2-2F series (page 342).

The grub (set) screws in the inner ring enable quick and easy mounting/dismounting. The bearings have a shield and a flinger on both sides to prevent the ingress of solid contaminants into the bearing.

The entire surface of the bearing and the shields are manganese phosphated to enhance adhesion of the lubricant to the metal and improve the running-in properties of the bearing. The flingers are treated by pickling.

The radial internal clearance is a multiple of C5 to prevent the bearings from seizing, even when they cool rapidly.

Designs and variants

The SKF assortment of insert bearings for high temperature applications (fig. 9) provides solutions for various combinations of operating temperature and speed.

The lubrication type, maximum operating temperature, limiting speed, maintenance requirements and all other primary characteristics of the variants within the assortment are listed in table 2.

Fig. 9

High temperature insert bearing variants

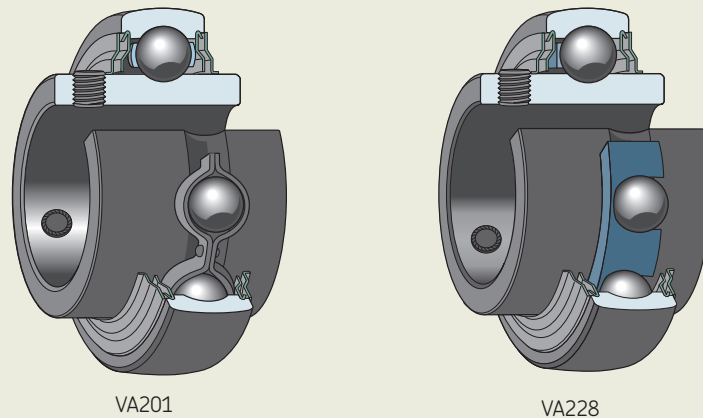

Table 2

Characteristics of high temperature variants for insert bearings

Characteristics	Variants VA201	VA228
Lubrication type	Polyalkylene glycol/ graphite mixture	Coronet cage made of graphite
Phosphated rings, rolling elements and cages	✓	✓
NSF H1 food grade	✗	✓
Shields and flingers (suffix 2F)	✓	✓
Relubrication-free	✓	✓
Maximum operating temperature	250 °C (480 °F)	350 °C (660 °F)
Limiting speed [r/min] ¹⁾	4 500 / d _m	9 000 / d _m

¹⁾ d_m = bearing mean diameter = 0,5 (d + D). For outer ring rotation, use d_m = D.

Sealing solutions

SKF high temperature insert bearings are capped on both sides with a shield and a flinger that create a narrow gap-type labyrinth seal (designation suffix 2F).

For high temperature bearings, metallic shields are the primary recommendation where a capping device with low complexity is required. The shields:

- prevent the ingress of solid contaminants into the bearing
- are non-contacting
- generate no friction
- do not wear
- are particularly well suited for high temperatures because of their material and design

Bearing data

	Deep groove ball bearings	Insert bearings (Y-bearings)
Dimension standards	Boundary dimensions: ISO 15 Series 10, 02, 03	Boundary dimensions: ISO 9628
Tolerances	Normal	Normal, except the bore and outside diameter (table 3, page 1012)
For additional information → page 35	Values: ISO 492 (table 2, page 1010) Owing to the special surface treatment of the bearings, there may be slight deviations from the standard tolerances. These deviations do not affect mounting or bearing operation.	
Radial internal clearance	Multiples of C5 Values (table 4, page 1012) are valid for unmounted bearings under zero measuring load.	
Permissible misalignment	≈ 20 to 30 minutes of arc Accommodate misalignment only when the bearings rotate slowly. Misalignment increases bearing noise and reduces bearing service life, and when it exceeds the guideline values, these effects become particularly noticeable.	
Stabilization	120 °C (250 °F)	150 °C (300 °F)
	The rings, rolling elements and cages of SKF high temperature bearings undergo the same heat stabilization process as the relevant standard bearing. As a result, for higher operating temperatures, a certain amount of dimensional change is to be expected. Greater clearances accommodate temperature differentials and material structural changes.	



Loads and selecting bearing size

The bearing size is selected based on the basic static load rating C_0 from the relevant product table.

For an equivalent static bearing load P_0 , the selected bearing must have a C_0 value \geq the value of the requisite basic static load rating C_{0req} (table 5).

The values in table 5 are valid only when $P_0 = F_r$. That is, when:

- $F_a < 0,8 F_r$
- $F_a < 0,15 C_0$

Symbols

- C_0 basic static load rating [kN] (product tables, page 1016 and page 1020)
- C_{0req} requisite basic static load rating [kN]
- F_a axial load [kN]
- F_r radial load [kN]
- P_0 equivalent static bearing load [kN]

Table 3

Tolerances of insert bearings for high temperature applications

Nominal diameter d, D		Bore diameter ¹⁾ Deviation		Outside diameter Deviation	
>	≤	U	L	U	L
mm		μm		μm	
18	30	+18	0	–	–
30	50	+21	0	0	–10
50	80	+24	0	0	–10
80	120	+28	0	0	–15

¹⁾ Values in accordance with ISO 9628.

Table 4

Radial internal clearance for high temperature bearings

Bore diameter		Radial internal clearance Deep groove ball bearings Multiples of C5		Insert bearings	
d	≤	min.	max.	min.	max.
mm		μm			
–	10	96	136	–	–
10	18	112	160	–	–
18	24	124	172	56	96
24	30	136	192	60	106
30	40	172	236	80	128
40	50	192	272	90	146
50	65	230	340	110	180
65	80	270	400	–	–
80	100	320	460	–	–
100	120	370	540	–	–

Fig. 10

Grub screw secured by a nut and a star lock washer

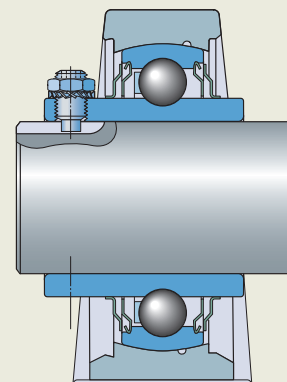

Design considerations

Location of bearings

Deep groove ball bearings

The selection of shaft and housing fits depends on the bearing operating condition and bearing size. An appropriate fit is needed to locate the shaft, provide satisfactory support and allow for thermal expansion up to the stated maximum operating bearing temperature (table 6).

Insert bearings

For moderate loads ($0,035 C < P \leq 0,05 C$), the shaft seats should be machined to an h7Ⓔ tolerance. For light loads and low speeds, an h8Ⓔ shaft tolerance is sufficient.

Symbols

- C basic dynamic load rating [kN] (page 1012)
- P equivalent dynamic bearing load [kN] (Loads for standard insert bearings, page 353)

Operating environment

SKF high temperature bearings are designed to provide solutions to common issues in high temperature applications. In addition to operations involving high temperatures and low rotational speeds, it is important to consider environmental conditions in the process area.

Since high temperature bearings are supplied without preservative oils and must be used without grease or oil lubrication, the anti-corrosion property of the bearings is limited. Therefore, the bearings should be used in a dry environment or with a proper sealing solution to keep the bearings dry.

Axial displacement

To accommodate axial displacement, the shaft at the non-locating bearing position of high temperature insert bearings should be provided with one or two grooves, 120° apart, to engage a modified grub screw:

- Hexagon socket grub (set) screws with a dog point, in accordance with ISO 4028, but with a fine thread according to table 10, page 357. The grub screw should be secured by a nut and a spring or star lock washer (fig. 10).

The screws and groove(s) accommodate changes in shaft length and prevent the shaft from turning independently of the bearing. The sliding surfaces between the shaft and inner ring and those in the shaft grooves should be coated with a lubricant paste suitable for the operating temperature.

Table 5

Requisite basic static load rating for applied equivalent static bearing load

Equivalent static bearing load P_0

Requisite basic static load rating C_{0req} for operating temperatures up to 250 °C (480 °F) 350 °C (660 °F)

kN	kN	
2	6	9
4	11	18
6	16	27
8	22	36
10	27	45
15	40	67
20	54	90
25	67	120
30	80	140
40	110	180
50	140	230
60	160	270
70	190	320
80	220	360
90	240	400
100	270	450
125	340	560
150	400	670
200	540	890
300	800	1 400
400	1 100	1 800
500	1 400	2 300
600	1 600	–



Table 6

Fits for high temperature deep groove ball bearings on solid steel shafts or in cast iron or steel housings

Conditions	Shaft diameter	Shaft tolerance	Housing tolerance
–	mm	–	–
Rotating inner ring load	all	k6	F7
Stationary inner ring load	all	g6	J7

Relubrication and running in

Relubrication

All SKF high temperature bearings are lubricated for the life of the bearing, except open VA201 deep groove ball bearings, which require relubrication.

The general recommendation for an open VA201 bearing is to investigate the quality of the lubricating paste in the bearing every six months. If there is no longer a film of dry lubricant on the raceways, indicated by a bright metallic shiny track, remove residues of the old lubricant with a solvent and, when dried, replenish the bearing with lubricating paste.

Running in

VA201 bearings operating at temperatures below 200 °C (390 °F) and at speeds below 25% of the limiting speed ([product tables](#), [page 1016](#) and [page 1020](#)) require running in. Open VA201 deep groove ball bearings operating under these conditions also require running in after relubrication.

Running in requires the bearing to be operated at a temperature of at least 200 °C (390 °F) for a minimum of 48 hours.

Mounting

SKF high temperature deep groove ball bearings should always be hot mounted to reduce the mounting force and the risk of breaking the graphite lubricant (VA208 and VA228 variants). An induction heater is the preferred choice to heat the bearing during mounting.

Submerging the bearing in hot oil is not recommended because the oil remaining in the bearing might carbonize later during operation.

Do not use impact mounting methods that could damage the bearing and prevent proper functionality.

Designation system

Refer to the *Designation system* of the relevant standard bearing:

- deep groove ball bearings, [page 258](#)
- insert bearings, [page 364](#)

Designation suffixes used with SKF bearings for high temperature applications are explained in the following:

- 2F** Insert bearing for high temperature applications, with grub screw locking, shield and flinger on both sides
- 2Z** Deep groove ball bearing for high temperature applications, shield on both sides
- VA201** Bearing for high temperature applications, with a stamped steel cage, manganese phosphate coated rings and rolling elements, radial clearance of multiples of C5, and lubricated with a polyalkylene glycol/graphite mixture
- VA208** Bearing for high temperature applications, with a segmented cage made of graphite, manganese phosphate coated rings and rolling elements, and radial clearance of multiples of C5
- VA228** Bearing for high temperature applications, with a coronet cage made of graphite, manganese phosphate coated rings and rolling elements, and radial clearance of multiples of C5
- W** Insert bearing for high temperature applications, without lubrication hole(s)



18.1 Single row deep groove ball bearings for high temperature applications
d 12 – 55 mm

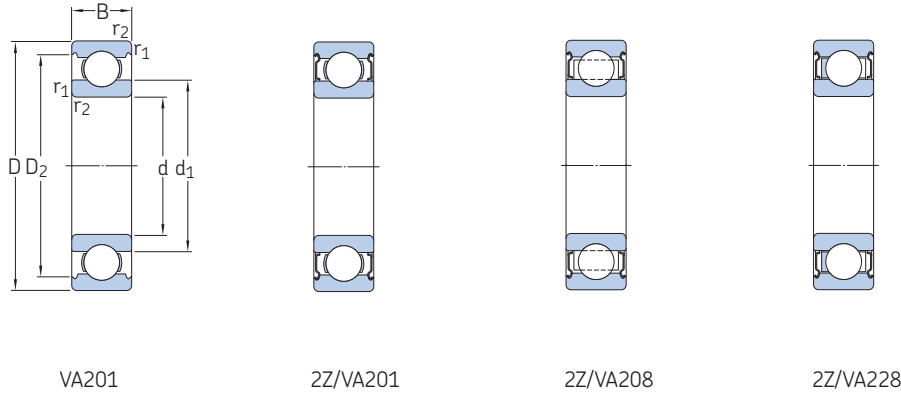

Dimensions						Basic static load rating	Limiting speed	Limiting temperature	Mass	Designation	
d	D	B	d ₁	D ₂	r _{1,2} min.	C ₀		T max.			
mm						kN	r/min	°C	kg	–	
12	32	10	18,4	27,4	0,6	3,1	400	250	0,037	6201/VA201	
	32	10	18,4	27,4	0,6	3,1	200	250	0,039	▶ 6201-2Z/VA201	
	32	10	18,4	27,4	0,6	3,1	400	350	0,039	▶ 6201-2Z/VA228	
15	35	11	21,7	30,4	0,6	3,75	360	250	0,045	▶ 6202/VA201	
	35	11	21,7	30,4	0,6	3,75	180	250	0,048	▶ 6202-2Z/VA201	
	35	11	21,7	30,4	0,6	3,75	360	350	0,048	▶ 6202-2Z/VA228	
17	35	10	23	31,2	0,3	3,25	340	250	0,038	6003/VA201	
	35	10	23	31,2	0,3	3,25	170	250	0,041	6003-2Z/VA201	
	35	10	23	31,2	0,3	3,25	170	350	0,041	6003-2Z/VA208	
40	40	12	24,5	35	0,6	4,75	310	250	0,065	6203/VA201	
	40	12	24,5	35	0,6	4,75	150	250	0,068	6203-2Z/VA201	
	40	12	24,5	35	0,6	4,75	310	350	0,068	▶ 6203-2Z/VA228	
47	47	14	26,5	39,6	1	6,55	280	250	0,11	6303/VA201	
	47	14	26,5	39,6	1	6,55	280	350	0,12	6303-2Z/VA228	
	20	42	12	27,2	37,2	0,6	5	290	250	0,067	6004/VA201
42		12	27,2	37,2	0,6	5	140	250	0,071	6004-2Z/VA201	
42		12	27,2	37,2	0,6	5	140	350	0,071	▶ 6004-2Z/VA208	
47	47	14	28,8	40,6	1	6,55	260	250	0,031	▶ 6204/VA201	
	47	14	28,8	40,6	1	6,55	130	250	0,11	▶ 6204-2Z/VA201	
	47	14	28,8	40,6	1	6,55	260	350	0,11	▶ 6204-2Z/VA228	
52	52	15	30,3	44,8	1,1	7,8	250	250	0,14	▶ 6304/VA201	
	52	15	30,3	44,8	1,1	7,8	120	250	0,15	6304-2Z/VA201	
	52	15	30,3	44,8	1,1	7,8	120	350	0,15	▶ 6304-2Z/VA208	
52	52	15	30,3	44,8	1,1	7,8	250	350	0,15	6304-2Z/VA228	
	25	47	12	32	42,2	0,6	6,55	250	250	0,078	6005/VA201
		47	12	32	42,2	0,6	6,55	120	250	0,083	▶ 6005-2Z/VA201
47		12	32	42,2	0,6	6,55	120	350	0,083	▶ 6005-2Z/VA208	
52	52	15	34,3	46,3	1	7,8	230	250	0,13	▶ 6205/VA201	
	52	15	34,3	46,3	1	7,8	110	250	0,13	▶ 6205-2Z/VA201	
	52	15	34,3	46,3	1	7,8	110	350	0,13	6205-2Z/VA208	
52	52	15	34,3	46,3	1	7,8	230	350	0,13	▶ 6205-2Z/VA228	
	62	17	36,6	52,7	1,1	11,6	200	250	0,23	6305/VA201	
	62	17	36,6	52,7	1,1	11,6	100	250	0,23	6305-2Z/VA201	
62	62	17	36,6	52,7	1,1	11,6	100	350	0,23	▶ 6305-2Z/VA208	
	62	17	36,6	52,7	1,1	11,6	200	350	0,23	▶ 6305-2Z/VA228	

▶ Popular item

Dimensions						Basic static load rating	Limiting speed	Limiting temperature	Mass	Designation	
d	D	B	d ₁ ≈	D ₂ ≈	r _{1,2} min.	C ₀		T max.			
mm						kN	r/min	°C	kg	–	
30	55	13	38,2	49	1	8,3	100	350	0,12	▶ 6006-2Z/VA208	
	62	16	40,3	54,1	1	11,2	190	250	0,2	▶ 6206/VA201	
	62	16	40,3	54,1	1	11,2	90	250	0,21	▶ 6206-2Z/VA201	
	62	16	40,3	54,1	1	11,2	90	350	0,21	▶ 6206-2Z/VA208	
	62	16	40,3	54,1	1	11,2	190	350	0,21	▶ 6206-2Z/VA228	
	72	19	44,6	61,9	1,1	16	170	250	0,35	6306/VA201	
	72	19	44,6	61,9	1,1	16	80	350	0,36	▶ 6306-2Z/VA208	
	72	19	44,6	61,9	1,1	16	170	350	0,36	6306-2Z/VA228	
	35	72	17	46,9	62,7	1,1	15,3	160	250	0,29	▶ 6207/VA201
		72	17	46,9	62,7	1,1	15,3	80	250	0,3	6207-2Z/VA201
72		17	46,9	62,7	1,1	15,3	80	350	0,3	▶ 6207-2Z/VA208	
72		17	46,9	62,7	1,1	15,3	160	350	0,3	▶ 6207-2Z/VA228	
80		21	49,5	69,2	1,5	19	150	250	0,46	6307/VA201	
80		21	49,5	69,2	1,5	19	70	350	0,48	▶ 6307-2Z/VA208	
40		68	15	49,2	61,1	1	11	80	350	0,2	▶ 6008-2Z/VA208
		80	18	52,6	69,8	1,1	19	150	250	0,37	6208/VA201
	80	18	52,6	69,8	1,1	19	70	250	0,38	▶ 6208-2Z/VA201	
	80	18	52,6	69,8	1,1	19	70	350	0,38	▶ 6208-2Z/VA208	
	80	18	52,6	69,8	1,1	19	150	350	0,38	▶ 6208-2Z/VA228	
	90	23	56,1	77,7	1,5	24	130	250	0,63	6308/VA201	
	90	23	56,1	77,7	1,5	24	60	250	0,65	6308-2Z/VA201	
	90	23	56,1	77,7	1,5	24	60	350	0,65	▶ 6308-2Z/VA208	
	90	23	56,1	77,7	1,5	24	130	350	0,65	6308-2Z/VA228	
	45	85	19	57,6	75,2	1,1	21,6	130	250	0,42	▶ 6209/VA201
85		19	57,6	75,2	1,1	21,6	60	250	0,43	6209-2Z/VA201	
85		19	57,6	75,2	1,1	21,6	60	350	0,43	▶ 6209-2Z/VA208	
85		19	57,6	75,2	1,1	21,6	130	350	0,43	6209-2Z/VA228	
100		25	62,1	86,7	1,5	31,5	120	250	0,84	6309/VA201	
100		25	62,1	86,7	1,5	31,5	60	350	0,87	6309-2Z/VA208	
50	80	16	59,7	72,8	1	15,6	60	350	0,27	6010-2Z/VA208	
	90	20	62,5	81,7	1,1	23,2	120	250	0,45	▶ 6210/VA201	
	90	20	62,5	81,7	1,1	23,2	60	250	0,47	6210-2Z/VA201	
	90	20	62,5	81,7	1,1	23,2	60	350	0,47	▶ 6210-2Z/VA208	
	90	20	62,5	81,7	1,1	23,2	120	350	0,47	▶ 6210-2Z/VA228	
	110	27	68,7	95,2	2	38	110	250	1,1	6310/VA201	
	110	27	68,7	95,2	2	38	50	250	1,1	6310-2Z/VA201	
	110	27	68,7	95,2	2	38	50	350	1,1	▶ 6310-2Z/VA208	
	110	27	68,7	95,2	2	38	110	350	1,1	6310-2Z/VA228	
	55	90	18	66,3	81,5	1,1	21,2	60	350	0,4	6011-2Z/VA208
100		21	69	89,4	1,5	29	110	250	0,61	▶ 6211/VA201	
100		21	69	89,4	1,5	29	50	250	0,64	6211-2Z/VA201	
100		21	69	89,4	1,5	29	50	350	0,64	▶ 6211-2Z/VA208	
100		21	69	89,4	1,5	29	110	350	0,64	6211-2Z/VA228	
120		29	75,3	104	2	45	100	250	1,35	6311/VA201	
120		29	75,3	104	2	45	50	250	1,4	6311-2Z/VA201	
120		29	75,3	104	2	45	50	350	1,4	6311-2Z/VA208	
120		29	75,3	104	2	45	100	350	1,4	6311-2Z/VA228	



18.1 Single row deep groove ball bearings for high temperature applications d 60 – 120 mm

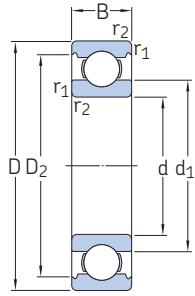

VA201

2Z/VA201

2Z/VA208

2Z/VA228

Dimensions						Basic static load rating	Limiting speed	Limiting temperature	Mass	Designation	
d	D	B	d ₁	D ₂	r _{1,2} min.	C ₀		T max.			
mm						kN	r/min	°C	kg	–	
60	110	22	75,5	98	1,5	36	100	250	0,78	▶ 6212/VA201	
	110	22	75,5	98	1,5	36	50	250	0,81	6212-2Z/VA201	
	110	22	75,5	98	1,5	36	50	350	0,81	▶ 6212-2Z/VA208	
	110	22	75,5	98	1,5	36	100	350	0,81	6212-2Z/VA228	
	130	31	81,8	113	2,1	52	90	250	1,7	6312/VA201	
	130	31	81,8	113	2,1	52	40	350	1,8	6312-2Z/VA208	
	130	31	81,8	113	2,1	52	90	350	1,8	6312-2Z/VA228	
	65	120	23	83,3	106	1,5	40,5	90	250	1	▶ 6213/VA201
		120	23	83,3	106	1,5	40,5	40	250	1,05	6213-2Z/VA201
		120	23	83,3	106	1,5	40,5	40	350	1,05	6213-2Z/VA208
		120	23	83,3	106	1,5	40,5	90	350	1,05	6213-2Z/VA228
		140	33	88,3	122	2,1	60	80	250	2,1	6313/VA201
140		33	88,3	122	2,1	60	40	250	2,2	6313-2Z/VA201	
140		33	88,3	122	2,1	60	40	350	2,2	6313-2Z/VA208	
140		33	88,3	122	2,1	60	80	350	2,2	6313-2Z/VA228	
70		125	24	87	111	1,5	45	90	250	1,1	6214/VA201
		125	24	87	111	1,5	45	40	250	1,15	6214-2Z/VA201
		125	24	87	111	1,5	45	40	350	1,15	▶ 6214-2Z/VA208
		125	24	87	111	1,5	45	90	350	1,15	6214-2Z/VA228
	150	35	94,9	130	2,1	68	80	250	2,55	6314/VA201	
	150	35	94,9	130	2,1	68	40	350	2,65	6314-2Z/VA208	
	75	130	25	92	117	1,5	49	80	250	1,2	▶ 6215/VA201
		130	25	92	117	1,5	49	40	250	1,25	6215-2Z/VA201
		130	25	92	117	1,5	49	40	350	1,25	6215-2Z/VA208
		130	25	92	117	1,5	49	80	350	1,25	6215-2Z/VA228
		160	37	101	139	2,1	76,5	70	250	3,05	6315/VA201
		160	37	101	139	2,1	76,5	30	350	3,15	6315-2Z/VA208
80		140	26	101	127	2	55	40	350	1,55	6216-2Z/VA208
		170	39	108	147	2,1	86,5	30	350	3,75	6316-2Z/VA208
85		150	28	106	135	2	64	70	250	1,8	6217/VA201
		150	28	106	135	2	64	30	350	1,9	6217-2Z/VA208
90		160	30	112	143	2	73,5	70	350	2,3	6218-2Z/VA228

▶ Popular item

Dimensions						Basic static load rating	Limiting speed	Limiting temperature	Mass	Designation
d	D	B	d ₁ ≈	D ₂ ≈	r _{1,2} min.	C ₀		T max.		
mm						kN	r/min	°C	kg	–
95	170	32	118	152	2,1	81,5	60	250	2,6	▶ 6219/VA201 ▶ 6219-2Z/VA201 ▶ 6219-2Z/VA228
	170	32	118	152	2,1	81,5	30	250	2,7	
	170	32	118	152	2,1	81,5	60	350	2,7	
100	150	24	115	139	1,5	54	30	350	1,35	6020-2Z/VA208 6220/VA201 6220-2Z/VA208 6220-2Z/VA228
	180	34	124	160	2,1	93	60	250	3,15	
	180	34	124	160	2,1	93	30	350	3,25	
	180	34	124	160	2,1	93	60	350	3,25	
	180	34	124	160	2,1	93	60	350	3,25	
110	170	28	129	156	2	73,5	30	350	2,05	6022-2Z/VA208
120	180	28	139	166	2	80	30	350	2,2	6024-2Z/VA208



18.2 Insert bearings for high temperature applications, metric shafts d 20 – 60 mm

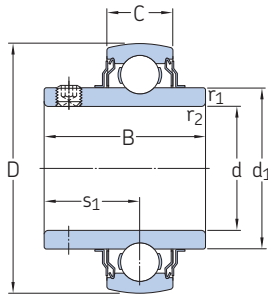

VA201

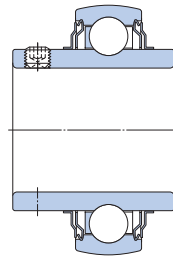

VA228

Dimensions							Basic load ratings		Limiting speed	Limiting temperature	Mass	Designation
d	D	B	C	d ₁	s ₁	r _{1,2} min.	C	C ₀				
mm							kN	r/min	°C	kg	–	
20	47	31	14	28,2	18,3	0,6	12,7	6,55	130	250	0,14	YAR 204-2FW/VA201
	47	31	14	28,2	18,3	0,6	12,7	6,55	260	350	0,14	► YAR 204-2FW/VA228
25	52	34,1	15	33,7	19,8	0,6	14	7,8	110	250	0,17	YAR 205-2FW/VA201
	52	34,1	15	33,7	19,8	0,6	14	7,8	230	350	0,17	YAR 205-2FW/VA228
30	62	38,1	18	39,7	22,2	0,6	19,5	11,2	90	250	0,28	YAR 206-2FW/VA201
	62	38,1	18	39,7	22,2	0,6	19,5	11,2	190	350	0,28	► YAR 206-2FW/VA228
35	72	42,9	19	46,1	25,4	1	25,5	15,3	80	250	0,41	YAR 207-2FW/VA201
	72	42,9	19	46,1	25,4	1	25,5	15,3	160	350	0,41	YAR 207-2FW/VA228
40	80	49,2	21	51,8	30,2	1	30,7	19	70	250	0,55	YAR 208-2FW/VA201
	80	49,2	21	51,8	30,2	1	30,7	19	150	350	0,55	YAR 208-2FW/VA228
45	85	49,2	22	56,8	30,2	1	33,2	21,6	60	250	0,6	YAR 209-2FW/VA201
	85	49,2	22	56,8	30,2	1	33,2	21,6	130	350	0,6	YAR 209-2FW/VA228
50	90	51,6	22	62,5	32,6	1	35,1	23,2	60	250	0,69	YAR 210-2FW/VA201
	90	51,6	22	62,5	32,6	1	35,1	23,2	120	350	0,69	YAR 210-2FW/VA228
55	100	55,6	25	69	33,4	1	43,6	29	50	250	0,94	YAR 211-2FW/VA201
	100	55,6	25	69	33,4	1	43,6	29	110	350	0,94	YAR 211-2FW/VA228
60	110	65,1	26	75,6	39,7	1,5	52,7	36	50	250	1,35	YAR 212-2FW/VA201
	110	65,1	26	75,6	39,7	1,5	52,7	36	100	350	1,35	YAR 212-2FW/VA228

► Popular item

18.3 Insert bearings for high temperature applications, inch shafts

d $\frac{3}{4}$ – 2 $\frac{15}{16}$ in.
19,05 – 74,613 mm

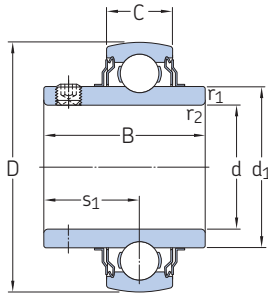

VA201

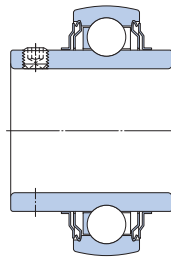

VA228

Dimensions							Basic load ratings		Limiting speed	Limiting temperature	Mass	Designation
d	D	B	C	d ₁	s ₁	r _{1,2} min.	C	C ₀				
in./mm	mm						kN		r/min	°C		
$\frac{3}{4}$ 19,05	47	31	14	28,2	18,3	0,6	12,7	6,55	130	250	0,17	YAR 204-012-2FW/VA201
	47	31	14	28,2	18,3	0,6	12,7	6,55	270	350	0,17	▶ YAR 204-012-2FW/VA228
1 25,4	52	34,1	15	33,7	19,8	0,6	14	7,8	110	250	0,19	YAR 205-100-2FW/VA201
	52	34,1	15	33,7	19,8	0,6	14	7,8	230	350	0,19	▶ YAR 205-100-2FW/VA228
1 $\frac{3}{16}$ 30,163	62	38,1	18	39,7	22,2	0,6	19,5	11,2	90	250	0,31	YAR 206-103-2FW/VA201
	62	38,1	18	39,7	22,2	0,6	19,5	11,2	190	350	0,31	▶ YAR 206-103-2FW/VA228
1 $\frac{1}{4}$ 31,75	72	42,9	19	46,1	25,4	1	25,5	15,3	80	250	0,52	YAR 207-104-2FW/VA201
	72	42,9	19	46,1	25,4	1	25,5	15,3	170	350	0,52	YAR 207-104-2FW/VA228
1 $\frac{3}{8}$ 34,925	72	42,9	19	46,1	25,4	1	25,5	15,3	80	250	0,46	YAR 207-106-2FW/VA201
	72	42,9	19	46,1	25,4	1	25,5	15,3	160	350	0,46	YAR 207-106-2FW/VA228
1 $\frac{7}{16}$ 36,513	72	42,9	19	46,1	25,4	1	25,5	15,3	80	250	0,42	YAR 207-107-2FW/VA201
	72	42,9	19	46,1	25,4	1	25,5	15,3	160	350	0,42	▶ YAR 207-107-2FW/VA228
1 $\frac{1}{2}$ 38,1	80	49,2	21	51,8	30,2	1	30,7	19	70	250	0,59	YAR 208-108-2FW/VA201
	80	49,2	21	51,8	30,2	1	30,7	19	150	350	0,59	▶ YAR 208-108-2FW/VA228
1 $\frac{11}{16}$ 42,863	85	49,2	22	56,8	30,2	1	33,2	21,6	70	250	0,75	YAR 209-111-2FW/VA201
	85	49,2	22	56,8	30,2	1	33,2	21,6	140	350	0,75	YAR 209-111-2FW/VA228
1 $\frac{3}{4}$ 44,45	85	49,2	22	56,8	30,2	1	33,2	21,6	60	250	0,62	YAR 209-112-2FW/VA201
	85	49,2	22	56,8	30,2	1	33,2	21,6	130	350	0,62	▶ YAR 209-112-2FW/VA228
1 $\frac{15}{16}$ 49,213	90	51,6	22	62,5	32,6	1	35,1	23,2	60	250	0,78	YAR 210-115-2FW/VA201
	90	51,6	22	62,5	32,6	1	35,1	23,2	120	350	0,78	YAR 210-115-2FW/VA228
2 50,8	100	55,6	25	69	33,4	1	43,6	29	50	250	1,1	YAR 211-200-2FW/VA201
	100	55,6	25	69	33,4	1	43,6	29	110	350	1,1	YAR 211-200-2FW/VA228
2 $\frac{3}{16}$ 55,563	100	55,6	25	69	33,4	1	25	29	50	250	1,05	YAR 211-203-2FW/VA201
	100	55,6	25	69	33,4	1	25	29	110	350	1,05	YAR 211-203-2FW/VA228
2 $\frac{7}{16}$ 61,913	110	65,1	26	75,6	39,7	1,5	52,7	36	50	250	1,35	YAR 212-207-2FW/VA201
	110	65,1	26	75,6	39,7	1,5	52,7	36	100	350	1,35	YAR 212-207-2FW/VA228
2 $\frac{15}{16}$ 74,613	130	73,3	29	92	46,3	1,5	66,3	49	40	250	2,2	YAR 215-215-2FW/VA201
	130	73,3	29	92	46,3	1,5	66,3	49	80	350	2,2	YAR 215-215-2FW/VA228

▶ Popular item

